

**UNITED STATES DISTRICT COURT  
EASTERN DISTRICT OF NEW YORK**

-----X  
INTERACTIVE WEARABLES, LLC,

Plaintiff,

**MEMORANDUM &  
ORDER**

-against-

Case No. 19-CV-3084 (GRB)

POLAR ELECTRO OY AND POLAR  
ELECTRO INC.,

Defendants.

-----X  
**GARY R. BROWN, United States District Judge.**

Before the Court is defendants Polar Electro Oy and Polar Electro Inc.’s (collectively, “Defendants”) Motion to Dismiss for lack of patent-eligible subject matter under 35 U.S.C. § 101 (the “Motion”). Docket Entry (“DE”) 22. For the reasons set forth below, the Court hereby GRANTS Defendants’ Motion and dismisses this case with prejudice.

I. Factual and Procedural History

On May 23, 2019, plaintiff Interactive Wearables, LLC’s (“Plaintiff”) filed a Complaint for Patent Infringement (“Complaint”) against Defendants, alleging that Defendants infringe United States Patent Numbers 9,668,016 (the “’016 Patent”) and 10,264,311 (the “’311 Patent”) (collectively, the “Asserted Patents”) through their making, using, testing, offering for sale, selling, and/or importing “smartwatches designed to operate with” remote control devices, including, for example, the Polar M600 watch. DE 1 at 7-9.

Both of the Asserted Patents relate to wearable content players that provide for the capacity to “provid[e] information [relating to content] in conjunction with media content.” ’016 Patent, col. 1 ll. 34-40.<sup>1</sup> The specification notes that, “[w]hile information regarding [radio broadcast

---

<sup>1</sup> As Plaintiff acknowledges, both patents share a common specification, and the differences between ’311 Patent, claim 32 and ’016 Patent, claim 32 are not material to Defendants’ Motion. DE 23 at 3 n.1, 4 n.2. Accordingly, all

content] can be introduced prior to, or announced subsequent to, the broadcast of the respective [content], the information is typically not provided during the course of the broadcast and, as a result, an individual who misses the respective introduction or announcement may never receive the desired information.” *Id.* at col. 1 l. 64–col. 2 l. 4. Similarly, “[a]n individual may also wish to know, without having to resort to a printed TV Guide, which may not be at hand, or having to switch channels to an online TV Guide, when the TV program, show or movie started and when it will finish or how much of it has been missed, in order to be able to decide whether or not to watch this TV program, show or movie.” *Id.* at col. 2 ll. 19-25. The invention addressed by the patents seeks to address this problem by “providing information in conjunction with media content, which [thereby] overcomes the shortfalls of the prior art” that could not “provide radio broadcasts or television broadcasts along with information regarding the content of the respective broadcast.” *Id.* at col. 2 ll. 40-48. Both patents contain five independent claims—claims 1, 11, 21, 31, and 32—and twenty-seven dependent claims. Representative claim 32<sup>2</sup> of the ’016 Patent recites:

32. A content player comprising:

a receiver configured to receive content and together with the content information associated with the content,

a processor coupled to the receiver and configured to process the content and the information associated with the content,

memory coupled to the processor,

a first display coupled to the processor, and

playing device equipment coupled to the processor and configured to provide the content to a user of the content player, the playing device equipment comprising an audio player; wherein the content player is a wearable content player configured to be controlled by a wireless remote control device comprising a second display, the wireless remote control device being configured to receive commands directing operations of the wearable content player, and wherein the wireless remote control device is configured to provide to the user at least a portion of the information associated with the content.

---

references herein to the specification and to claim 32 are to the specification and claim 32, respectively, of the ’016 Patent.

<sup>2</sup> As Plaintiff itself asserts, claim 32 of each Asserted Patent is merely “exemplary.” DE 11-1; *see also* DE 1 at 4.

*Id.* at col. 26 ll. 7-27. Independent claims 1 and 31 recite substantially the same concept but add that the remote control device is “wirelessly coupled” with the content player. *Id.* at col. 22 ll. 1-24, col. 25 l. 12–col. 26 l. 6. In turn, independent claims 11 and 21 recite substantially the same concept but do so in the context of a method; claim 11 further lacks the limitation of a memory coupled to the processor. *Id.* at col. 23 ll. 1-21, col. 24 ll. 16-34.

Defendants filed the fully briefed Motion on December 23, 2019, following the consent of the parties to the undersigned, then serving as a magistrate judge, for all purposes. Subsequently, the undersigned was confirmed as a United States District Judge. However, in the interests of judicial economy, the undersigned retained jurisdiction over this matter pending its resolution.

## II. Legal Standards

### A. Patent Eligibility Under 35 U.S.C. § 101

Anyone who “invents or discovers any new and useful process, machine, manufacture, or composition of matter, or any new and useful improvement thereof” may obtain a patent. 35 U.S.C. § 101. The Supreme Court has “long held that this provision contains an important implicit exception[:] Laws of nature, natural phenomena, and abstract ideas are not patentable.” *Ass’n for Molecular Pathology v. Myriad Genetics, Inc.*, 569 U.S. 576, 589 (2013) (quoting *Mayo Collaborative Servs. v. Prometheus Labs., Inc.*, 566 U.S. 66, 70 (2012)). Accordingly, in addressing patentability under § 101, the Court must distinguish between claims that merely set forth these “building blocks of human ingenuity” and those that “integrate the building blocks into something more.” *Alice Corp. Pty. Ltd. v. CLS Bank Int’l*, 573 U.S. 208, 216-17 (2014).

Under the two-part test described by the Supreme Court in *Alice*, the Court “must first determine whether the claims at issue are directed to a patent-ineligible concept,” such as an abstract idea. *Alice*, 573 U.S. at 218. This inquiry is not concerned merely with “whether the claims involve a patent-ineligible concept”; rather, it “applies a stage-one filter to claims, considered in light of the specification, based on whether ‘their character as a whole is directed to excluded subject matter.’” *Enfish, LLC v. Microsoft Corp.*, 822 F.3d 1327, 1335 (Fed. Cir. 2016) (quoting *Internet Patents Corp. v. Active Network, Inc.*, 790 F.3d 1343, 1346 (Fed. Cir. 2015)). Thus, as Plaintiff observes, the first step of the *Alice* framework is concerned with the “risk that a claim

will pre-empt others from using an abstract idea” regardless of its implementation. DE 23 at 11; *see, e.g., Mayo*, 566 U.S. at 72; *Alice*, 573 U.S. at 216, 223. In contrast, “claims ‘purport[ing] to improve the functioning of the computer itself,’ or ‘improv[ing] an existing technological process’ might not succumb to the abstract idea exception.” *Enfish*, 822 F.3d at 1335 (quoting *Alice*, 573 U.S. at 223-25). As in *Enfish*, “the first step in the *Alice* inquiry in this case asks whether the focus of the claims is on the specific asserted improvement in computer capabilities . . . or, instead, on a process that qualifies as an ‘abstract idea’ for which computers are invoked merely as a tool.” *Enfish*, 822 F.3d at 1335-36.<sup>3</sup>

If the challenged claims are found to recite a patent-ineligible concept, the Court must then “examine the elements of the claim[s]” to establish whether they “include ‘additional features’ to ensure ‘that the [claims] [are] more than a drafting effort designed to monopolize the [abstract idea].’” *Alice*, 573 U.S. at 221 (quoting *Mayo*, 566 U.S. at 77). The Court must “consider the elements of each claim both individually and ‘as an ordered combination’ to determine whether the additional elements ‘transform the nature of the claim’ into a patent-eligible application.” *Alice*, 573 U.S. at 217 (quoting *Mayo*, 566 U.S. at 78). This second step is described “as a search for an ‘inventive concept’—*i.e.*, an element or combination of elements that is ‘sufficient to ensure that the patent in practice amounts to significantly more than a patent upon the [ineligible concept] itself.’” *Id.* at 217-18 (quoting *Mayo*, 566 U.S. at 72-73). “An inventive concept that transforms the abstract idea into a patent-eligible invention must be significantly more than the abstract idea itself, and cannot simply be an instruction to implement or apply the abstract idea on a computer.” *BASCOM Glob. Internet Servs., Inc. v. AT&T Mobility LLC*, 827 F.3d 1341, 1349 (Fed. Cir. 2016) (citing *Alice*, 573 U.S. at 222-23). Nor does it suffice to “limit[] the use of an abstract idea ‘to a particular technological environment.’” *Alice*, 573 U.S. at 223 (quoting *Bilski v. Kappos*, 561 U.S. 593, 610-11 (2010)). Rather, the claims “must involve more than performance of ‘well-understood, routine, conventional activit[ies] previously known to the industry.’” *TLI Commc’ns*, 823 F.3d at 613 (quoting *Alice*, 573 U.S. at 225); *see also Content Extraction & Transmission LLC v. Wells Fargo Bank, Nat. Ass’n*, 776 F.3d 1343, 1347–48 (Fed. Cir. 2014). The use of conventional

---

<sup>3</sup> Although at least a subset of the claims at issue here are directed to hardware (*i.e.*, a content player), in contrast to the software-related claims at issue in *Enfish*, the claims are, like those in *Enfish*, nevertheless addressed to “computer-related technology” such as a receiver, a processor, a memory, and a display. ’016 Patent, col. 26 ll. 7-27; *Enfish*, 822 F.3d at 1335-36; *see also In re TLI Commc’ns LLC Patent Litig.*, 823 F.3d 607, 610-12 (Fed. Cir. 2016) (applying a similar inquiry for claims directed to the use of a “telephone unit,” a “server,” an “image analysis unit,” and a “control unit”).

components is not, on its own, necessarily a bar to finding an inventive concept, as “an inventive concept can be found in the non-conventional and non-generic arrangement of known, conventional pieces.” *BASCOM*, 827 F.3d at 1350. Whether through non-conventional components or arrangement, however, the claims must “improve the functioning of the computer itself . . . [or] effect an improvement in any other technology or technical field.” *Alice*, 573 U.S. at 225. For example, a claim may exhibit an inventive concept where it is addressed to “a technical solution to a problem unique to” the relevant field. *BASCOM*, 827 F.3d at 1351; *see also Aatrix Software, Inc. v. Green Shades Software, Inc.*, 882 F.3d 1121, 1127 (Fed. Cir. 2018) (finding an inventive concept where the complaint “present[ed] specific allegations directed to ‘improvements and problems solved by the . . . patented inventions.’”). Such a solution should “explain[] how [the] particular arrangement of elements” is “a technical improvement over prior art . . .” *Amdocs (Israel) Ltd. v. Openet Telecom, Inc.*, 841 F.3d 1288, 1299 (Fed. Cir. 2016).

In summary, then, “[t]he ‘abstract idea’ step of the inquiry calls upon us to look at the ‘focus of the claimed advance over the prior art’ to determine if the claim’s ‘character as a whole’ is directed to excluded subject matter. The ‘inventive concept’ step requires us to look with more specificity at what the claim elements add, in order to determine ‘whether they identify an “inventive concept” in the application of the ineligible subject matter’ to which the claim is directed.” *Affinity Labs of Texas, LLC v. DIRECTV, LLC*, 838 F.3d 1253, 1257–58 (Fed. Cir. 2016).

In conducting this analysis, courts “‘must be careful to avoid oversimplifying the claims’ by looking at them generally and failing to account for the specific requirements of the claims.” *McRO, Inc. v. Bandai Namco Games Am. Inc.*, 837 F.3d 1299, 1313 (Fed. Cir. 2016) (quoting *TLI Commc'ns*, 823 F.3d at 611). Thus, “[w]hether at step one or step two of the *Alice* test, in determining the patentability of a method, a court must look to the claims as an ordered combination, without ignoring the requirements of the individual steps.” *Id.* Conversely, “[t]he Supreme Court has stated that a § 101 patentability analysis is directed to the claim as a whole, not individual limitations.” *King Pharm., Inc. v. Eon Labs, Inc.*, 616 F.3d 1267, 1277 (Fed. Cir. 2010). Accordingly, “it is irrelevant that any individual step or limitation of such processes by itself would be unpatentable under § 101.” *In re Bilski*, 545 F.3d 943, 958 (Fed. Cir. 2008). As a result, “even though a fundamental principle itself is not patent-eligible, processes incorporating a fundamental principle may be patent-eligible.” *Id.* For example, “a new and useful arrangement of known

components can be patent-eligible.” *Immersion Corp. v. Fitbit, Inc.*, 313 F. Supp. 3d 1005, 1024 (N.D. Cal. 2018) (citing *Thales Visionix Inc. v. United States*, 850 F.3d 1343, 1348-49 (Fed. Cir. 2017)); *see also Two-Way Media Ltd. v. Comcast Cable Commc'ns, LLC*, 874 F.3d 1329, 1339 (Fed. Cir. 2017) (“[A]n inventive concept can be found in the non-conventional and non-generic arrangement of known, conventional pieces.”). Furthermore, while examining the specification may help to illuminate the claims, “[u]ltimately, ‘[t]he § 101 inquiry must focus on the language of the Asserted Claims themselves,’ and the specification cannot be used to import details from the specification if those details are not claimed. Even a specification full of technical details about a physical invention may nonetheless conclude with claims that claim nothing more than the broad law or abstract idea underlying the claims, thus preempting all use of that law or idea.” *ChargePoint, Inc. v. SemaConnect, Inc.*, 920 F.3d 759, 769 (Fed. Cir. 2019) (quoting *Synopsys, Inc. v. Mentor Graphics Corp.*, 839 F.3d 1138, 1149 (Fed. Cir. 2016)).

#### B. Ruling on Patent Eligibility at the Pleadings Stage

“While the ultimate determination of eligibility under § 101 is a question of law, like many legal questions, there can be subsidiary fact questions which must be resolved en route to the ultimate legal determination.” *Aatrix*, 882 F.3d at 1128. “[W]hether a claim element or combination of elements is well-understood, routine and conventional to a skilled artisan in the relevant field”—i.e., the second step of the *Alice* framework—is one such subsidiary question, which ordinarily “must be proven by clear and convincing evidence.” *Berkheimer v. HP Inc.*, 881 F.3d 1360, 1368 (Fed. Cir. 2018) (“*Berkheimer I*”). Patent eligibility can nevertheless be determined at the Rule 12(b)(6) stage, but doing so is appropriate “only when there are no factual allegations that, taken as true, prevent resolving the eligibility question as a matter of law.” *Aatrix*, 882 F.3d at 1125; *see also FairWarning IP, LLC v. Iatric Sys., Inc.*, 839 F.3d 1089, 1097 (Fed. Cir. 2016). In addressing this question, the Court may only look to allegations in “the sources properly considered on a motion to dismiss, such as the complaint, the patent, and materials subject to judicial notice.” *Aatrix*, 882 F.3d at 1128. Thus, the Court may look beyond the patent, specifically to the complaint, for plausible allegations that the claims contain a sufficient “inventive concept.” *See id.* at 1126-27. However, the Court “need not ‘accept as true allegations that contradict matters properly subject to judicial notice or by exhibit,’ such as the claims and the

patent specification.” *Secured Mail Sols. LLC v. Universal Wilde, Inc.*, 873 F.3d 905, 913 (Fed. Cir. 2017) (quoting *Anderson v. Kimberly-Clark Corp.*, 570 F. App'x 927, 931 (Fed. Cir. 2014)).

Thus, “plausible factual allegations may preclude dismissing a case under § 101 where, for example, nothing on th[e] record ... refutes those allegations as a matter of law or justifies dismissal under Rule 12(b)(6).” *Aatrix*, 882 F.3d at 1125 (internal quotations omitted). For example, in *Aatrix*, the Federal Circuit reversed the district court’s dismissal of a claim on § 101 grounds where there were “concrete allegations in the . . . complaint that individual elements and the claimed combination [were] not well-understood, routine, or conventional activity.” *Id.* at 1128. However, as observed in *Aatrix*, only *plausible* allegations will suffice, such that “mere conclusory statements” as to the inventiveness of the claims will not suffice. *Ashcroft v. Iqbal*, 556 U.S. 662, 678 (2009); *see also Berkheimer v. HP Inc.*, 890 F.3d 1369, 1372 (Fed. Cir. 2018) (“Berkheimer II”) (for a § 101 challenge in a motion to dismiss, the Court “must apply the well-settled Rule 12(b)(6) standard” whereby the motion “must be denied if ‘in the light most favorable to the plaintiff and with every doubt resolved in the pleader's favor—but disregarding mere conclusory statements—the complaint states any legally cognizable claim for relief.’” (Moore, J., concurring) (citation omitted)); *Cellspin Soft, Inc. v. Fitbit, Inc.*, 927 F.3d 1306, 1317 (Fed. Cir. 2019) (“While we do not read *Aatrix* to say that any allegation about inventiveness, wholly divorced from the claims or the specification, defeats a motion to dismiss, plausible and specific factual allegations that aspects of the claims are inventive are sufficient.”).

### C. Ruling on the Claims Collectively

Addressing every claim of a challenged patent individually is not necessary where multiple claims are “substantially similar and linked to the same abstract idea.” *Content Extraction*, 776 F.3d at 1348. Thus, where the claims asserted in the patent “contain only ‘minor differences in terminology [but] require performance of the same basic process,’ they should rise or fall together.” *Accenture Glob. Servs., GmbH v. Guidewire Software, Inc.*, 728 F.3d 1336, 1344 (Fed. Cir. 2013) (quoting *CLS Bank Int'l v. Alice Corp. Pty.*, 717 F.3d 1269, 1291 (Fed. Cir. 2013) (plurality opinion), *aff'd*, 573 U.S. 208 (2014)).

As indicated above, other than the “wirelessly coupled” limitation of claims 1 and 31, the other independent claims of the Asserted Patents “contain insignificant meaningful limitations” to



distinguish them from claim 32. *Accenture Glob. Servs.*, 728 F.3d at 1344. In fact, these other claims are largely “almost verbatim duplicate[s]” of claim 32, and the specification “makes little distinction between the system and method claims.” *Id.* at 1343. The various dependent claims fare no better, as their additional limitations merely specify generic means of content transmission (*see, e.g.*, ’016 Patent, col. 22 ll. 46-52, col. 23 ll. 49-62), add generic components (*see, e.g., id.* at col. 22 ll. 58-59, col. 24 ll. 1-4), or specify the format or type of the information provided (*see, e.g., id.* at col. 22 ll. 60-67, col. 24 ll. 5-14). Moreover, Plaintiff “never asserted in its opposition” that this Court “should . . . differentiate[] any claim from those identified as representative” in its Complaint, nor did Plaintiff “identify any other claims as purportedly containing an inventive concept” that was absent in claim 32. *Content Extraction*, 776 F.3d at 1348; *see also* DE 1 at 5-7. Indeed, Plaintiff “neither argues for the validity of any other claim if claim [32] is invalid nor presents any meaningful argument for the distinctive significance of any claim limitations other than those included in claim [32].” *Elec. Power Grp., LLC v. Alstom S.A.*, 830 F.3d 1350, 1352 (Fed. Cir. 2016).<sup>4</sup>

Accordingly, in this case “the Court is free to dispose of the additional claims in a less detailed fashion.” *Content Extraction & Transmission LLC v. Wells Fargo Bank, Nat. Ass’n*, No. 12-2501 MAS TJB, 2013 WL 3964909, at \*5 (D.N.J. July 31, 2013), *aff’d*, 776 F.3d 1343 (Fed. Cir. 2014) (collecting cases); *see also Planet Bingo, LLC v. VKGS LLC*, 576 F. App’x 1005, 1007 (Fed. Cir. 2014) (dispensing with various claims without individualized analysis where “[t]he system claims recite the same basic process as the method claims, and the dependent claims recite only slight variations of the independent claims”); *Accenture Glob. Servs.*, 728 F.3d at 1343-44. Therefore, although disposing of all of the claims in the Asserted Patents, the Court will restrict its analysis here to claim 32, as well as the additional limitation of a “wirelessly coupled” remote as set forth in claims 1 and 31 and their respective dependent claims.

---

<sup>4</sup> To be sure, Plaintiff *does* distinguish claim 32 from other claims reciting “broadcasting or communication systems,” but does so only to address the argument that the specification describes these systems in conventional and generic ways. DE 23 at 17. Furthermore, Plaintiff cites the capacity for “wireless[] coupl[ing],” which is recited in claims 1 and 31 but *not* in claim 32, as providing an inventive concept. *Id.* at 14. These references suggest that Plaintiff has raised all claim limitations in its Complaint and opposition that might provide an inventive concept.



### III. Discussion

#### A. *Alice* Step One: Whether the Claims are Directed to a Patent-Ineligible Abstract Idea

Turning to the first step of the *Alice* framework, the Court “must first determine whether the claims at issue are directed to a patent-ineligible concept,” such as an abstract idea. *Alice*, 573 U.S. at 218. To reiterate, “[t]he ‘abstract idea’ step of the inquiry calls upon us to look at the ‘focus of the claimed advance over the prior art’ to determine if the claim’s ‘character as a whole’ is directed to excluded subject matter.” *Affinity Labs*, 838 F.3d at 1257 (Fed. Cir. 2016). Defendants argue that “the Asserted Claims recite the abstract idea of providing information related to certain media . . . using a content player that includes generic components used for their common purpose.” DE 22 at 1, 11. They contend that “providing information about content to a user” is analogous to other abstract ideas found to be patent-ineligible by the Supreme Court and Federal Circuit. *Id.* at 13-14. According to Defendants, the Asserted Patents are therefore “directed to . . . an abstract idea – and not directed to an improvement in how computers or networks function.” *Id.* at 14.

Plaintiff responds that, rather than being directed to an abstract idea, the claims are instead “directed to a physical device having a specific combination of non-generic hardware components with specific features—namely, a content player that, among other things, is wearable, receives content together with information about the content, and wirelessly pairs with a remote control.” DE 23 at 1. Plaintiff contends that Defendants therefore “ignore the entirety of the actual device recited in the claims” by “characterizing the claims as directed to merely ‘providing information.’” *Id.* Instead, Plaintiff claims that the Asserted Patents “are indisputably directed to concrete, tangible things, devices comprised of particularized electronic components, each with its own separate function.” *Id.* at 7. As a result, the Asserted Patents cannot “pre-empt the entire idea of ‘providing information related to media content’” due to the “specific claimed content player/remote combination” that the Asserted Patents are directed to. *Id.* at 11-12. Plaintiff thus contends that Defendants “ignore[] the vast majority of claim limitations” set out in the Asserted Patents and portray the claims at too high a level of abstraction, missing, for example, that with the asserted limitations the claims “cannot be practiced . . . in the human mind.” *Id.*

Ultimately, neither party accurately captures what the claims are directed to. A closer examination of the specification helps to clarify the inquiry: “[w]hile ‘[t]he § 101 inquiry must focus on the language of the Asserted Claims themselves,’ the specification may nonetheless be useful in illuminating whether the claims are ‘directed to’ the identified abstract idea. For example . . . [t]he ‘directed to’ inquiry may . . . involve looking to the specification to understand ‘the problem facing the inventor’ and, ultimately, what the patent describes as the invention.” *ChargePoint*, 920 F.3d at 767 (internal citations omitted). In this case, the Asserted Patents specifically identify the problem as being the failure of the prior art to “provide . . . broadcasts along with information regarding the content of the respective broadcast,” which the claimed invention overcomes by setting out “an apparatus and method for providing information in conjunction with media content.” ’016 Patent, col. 2 ll. 37-55.<sup>5</sup> Nothing else is described in the specification as the invention. For example, the enumerated objects of the invention are all variations of “providing information in conjunction with media content.” ’016 Patent, col. 5 l. 54–col. 7 l. 63. Similarly, the description of the preferred embodiments fails to present any alternative focus of the claims. To the extent it describes specific components, it is merely to point out—without specifics—how they achieve this result, not to indicate that the components or their arrangement are a separate improvement in and of themselves, or that they accomplish a specific and inventive *means* of providing information. The same is true of the figures; for example, Figures 1-3 display schematics whose hardware “is merely composed of generic computer components that would be present in any general purpose computer,” such as a central processing computer, a memory device, an input device, and a display device. *Accenture Glob. Servs.*, 728 F.3d at 1343.<sup>6</sup>

---

<sup>5</sup> Plaintiff’s assertions in its opposition further support this conclusion. Plaintiff claims that the Asserted Patents “identify and set out to solve problems related to then-existing players of audio and visual media content.” DE 23 at 2. But the only problem Plaintiff identifies as being solved is that of “provid[ing] information about media content being played . . . during the playing of such content.” *Id.* at 3. Similarly, the inability to “provide radio broadcasts or television broadcasts along with information regarding the content of the respective broadcast” is the only “shortfall[] of the prior art” that Plaintiff identifies as being overcome by the Asserted Patents. *Id.*

<sup>6</sup> In fact, the specification goes to great lengths to avoid any specifics in describing the components. For example, the media-playing device “can be any one or more of [various content playing devices]”; the overall apparatus “can operate and/or can be utilized on, over, and/or in conjunction with, any suitable communication network or system”; the media-playing device “can include media-playing device equipment . . . which can include any and/or all of the components and systems of the respective media-playing device,” “can include a reading device for reading information from a storage medium, such as [various content playing devices],” and “can also include a central processing computer” which “can include . . . any . . . components or devices . . . for performing any of the functionality described herein”; the media-playing device “can also include an input device . . . which can include a remote control device, for inputting information and/or commands into the media-playing device” and “can also include a display device”; and the display device “can . . . be integrated with the respective display screen . . . of the

In short, the specification here “never suggests that the [content player] itself is improved from a technical perspective, or that it would operate differently than it otherwise could. Nor does the specification suggest that the invention involved overcoming some sort of technical difficulty in adding [simultaneous information provision] capability to the [content players].” *ChargePoint*, 920 F.3d at 768.

In other words, the elements of the claims are thoroughly result-oriented: each of the terms “simply demands the production of a desired result . . . without any limitation on how to produce that result.” *Interval Licensing LLC v. AOL, Inc.*, 896 F.3d 1335, 1345 (Fed. Cir. 2018). “The specification fails to provide any technical details for the tangible components, but instead predominately describes the system and methods in purely functional terms.” *TLI Commc’ns*, 823 F.3d at 612. For example, the “receiver” set out in the claims (referred to, in conjunction with the “playing device equipment,” as the “media-playing device” in the specification) “refers to . . . any . . . suitable devices or systems which can be utilized in order to receive and present” media content, or even more broadly, “any . . . suitable device.” ’016 Patent, col. 9 l. 62–col. 10 l. 6, col. 18 l. 47-52. “Put differently, the [receiver and playing device equipment] itself is merely a conduit for the abstract idea” of receiving and presenting information together with media content. *TLI Commc’ns*, 823 F.3d at 612. Similarly, the “remote control device” is described merely in terms of its function, i.e., that of “inputting information and/or commands” or “provid[ing] remote control over the operation of the media-playing device.” ’016 Patent, col. 4 ll. 26-27, col. 13 ll. 3-7. “[T]he functions of” each of the components are thus “described in vague terms without any meaningful limitations,” indicating that “the focus of the patentee and of the claims was not on an improved” version of any of these components. *TLI Commc’ns*, 823 F.3d at 612-13.

The language of claim 32 itself reinforces this conclusion: each recited component—e.g., “a receiver configured to receive,” “a processor . . . configured to process,” or “a wireless remote control” that is “configured to . . . control[]” and “direct[] operations” of the content player,” ’016 Patent, col. 26 ll. 7-27—fails to present a “specific improvement to computer functionality.” *TLI Commc’ns*, 823 F.3d at 612. This “result-centric construction” for each of the components therefore “conforms with the specification, which,” as noted above, “lacks any description for how” the components achieve their functions, or how they achieve the overall solution of providing

---

respective media-playing device,” and/or can “be located on the remote control device.” ’016 Patent, col. 11 l. 4-col. 13 l. 19.

information in conjunction with media content. *Interval Licensing*, 896 F.3d at 1345. Rather, the claim merely presents “the use of conventional or generic technology in a nascent but well-known environment, without any claim that the invention reflects an inventive solution to any problem presented by combining the two.” *TLI Commc’ns*, 823 F.3d at 612. “The problem facing the inventor was not,” for example, making content players wearable or enabling wireless pairing with a remote control, “[n]or was the problem related to the structure of” the content player itself. *Id.* “Rather, the inventor sought to ‘provid[e] for’” the ability to access information about a program during the program itself. *Id.* “In short, looking at the problem identified in the patent, as well as the way the patent describes the invention,” the claims and specification “suggest that the invention of the patent is nothing more than the abstract idea” of providing information in conjunction with media content, “applied to the context” of content players. *ChargePoint*, 920 F.3d at 768. Thus, the claims are not focused on a “specific asserted improvement in computer capabilities,” but rather are directed to “an ‘abstract idea’ for which computers are invoked merely as a tool,” i.e., that of providing information in conjunction with media content. *Enfish*, 822 F.3d at 1335-36.

The claims at issue here are, in fact, remarkably similar to those addressed by the Federal Circuit in *Interval Licensing*. The patent at issue in that case claimed a system that, among other aspects, entailed “the display of a second set of data in an area that does not overlap with an already-displayed first set of data.” *Interval Licensing*, 896 F.3d at 1338. The “focus of the claims,” i.e., that of “providing someone an additional set of information without disrupting the ongoing provision of an initial set of information,” is thus essentially the same, and similarly abstract. *Id.* at 1344.<sup>7</sup> Indeed, the Federal Circuit’s comparison of the claims in that case to “passing a note to a person who is in the middle of a meeting,” *id.*, is strikingly similar to the Asserted Patents’ own reference to consulting a TV Guide while watching a program, ’016 Patent, col. 2 ll. 10-25. The only meaningful distinctions in the present case are that the claims here call for a paired remote control and for the content player to be wearable. But as discussed above, these distinctions fail to alter the conclusion that the claims are directed to an abstract concept. Rather, the claims still

---

<sup>7</sup> The Federal Circuit has found similar concepts to be abstract in multiple cases. See, e.g., *Elec. Power Grp.*, 830 F.3d at 1354. (finding “a process of gathering and analyzing information of a specified content, then displaying the results,” without presenting “any particular assertedly inventive technology for performing those functions,” to be abstract); *W. View Research, LLC v. Audi AG*, 685 F. App’x 923, 926 (Fed. Cir. 2017) (“[C]ollecting information, analyzing it, and displaying certain results of the collection and analysis’ are ‘a familiar class of claims “directed to” a patent-ineligible concept.’”) (quoting *Elec. Power Grp.*, 830 F.3d at 1353); *SAP Am., Inc. v. InvestPic, LLC*, 898 F.3d 1161, 1167 (Fed. Cir. 2018) (“[S]electing certain information, analyzing it using mathematical techniques, and reporting or displaying the results of the analysis . . . is all abstract.”).

merely “consist of generic and conventional . . . steps that are connected to, but do not convert, the abstract idea—displaying a second set of data without interfering with a first set of data—into a particular conception of how to carry out that concept.” *Interval Licensing*, 896 F.3d at 1346. As a result, the claims here merely apply the abstract idea behind consulting a TV Guide—i.e., “to obtain more information” about a program while viewing it—to a content player, rather than “provide[] a technological improvement” to the content player itself. *Id.* at 1344; ’016 Patent, col. 2 ll. 10-25.

Plaintiff’s argument that the claimed device recites “concrete, tangible” components fails to alter this conclusion. After all, the fact that the claims are “associated with a physical machine that is quite tangible . . . is not dispositive.” *ChargePoint, Inc.*, 920 F.3d at 770; *see also TLI Commc’ns*, 823 F.3d at 611 (“[N]ot every claim that recites concrete, tangible components escapes the reach of the abstract-idea inquiry.”) (collecting cases). “Resolving the § 101 inquiry based on such an argument would make the determination of patent eligibility depend simply on the draftsman’s art.” *ChargePoint*, 920 F.3d at 770 (internal quotations and citations omitted). Plaintiff’s argument is comparable to that of the plaintiff in *ChargePoint* and fails for similar reasons. Plaintiff “contends that the various physical components in [claim 32] show that the claims ‘do not recite the general concept’” of providing information in conjunction with media content, *ChargePoint*, 920 F.3d at 772, but rather recite “concrete . . . devices” that include, for example, “‘a content player’ which is wearable and has a first display and playing device equipment, and which can be wirelessly coupled with a remote control that has a second display,” DE 23 at 7-8. That is, Plaintiff merely reiterates the limitations set out in claim 32 to point out that they are addressed to concrete components. DE 23 at 7-8, 11. But as noted above, “the specification does not suggest that the inventors’ discovery” was a wearable device, or wireless coupling, or even any specific concrete device. *ChargePoint*, 920 F.3d at 772. The physical components are not described with “the specificity required to transform a claim from one claiming only a result to one claiming a way of achieving it.” *InvestPic*, 898 F.3d at 1167. Indeed, “there is no indication that the invention of the . . . patent was intended to improve those particular components or that the inventors viewed the combination of those components as their invention. The only improvement alleged” is the capacity to provide information *in conjunction* with transmitted media content. *ChargePoint*, 920 F.3d at 772. That is, “the focus of the claims is not a physical-realm improvement but an improvement in [a] wholly abstract idea[.]” *InvestPic*, 898 F.3d at 1168. As a

result, “the recited physical components merely provide a generic environment in which to carry out” this abstract idea, *TLI Commc’ns*, 823 F.3d at 611, which “remains the focus of [the claims], thus making [them] directed to an abstract idea,” *ChargePoint*, 920 F.3d at 773.

In this regard, the technical diagrams contained in the patent prove revelatory. Consider the following figure found in the patent in suit:

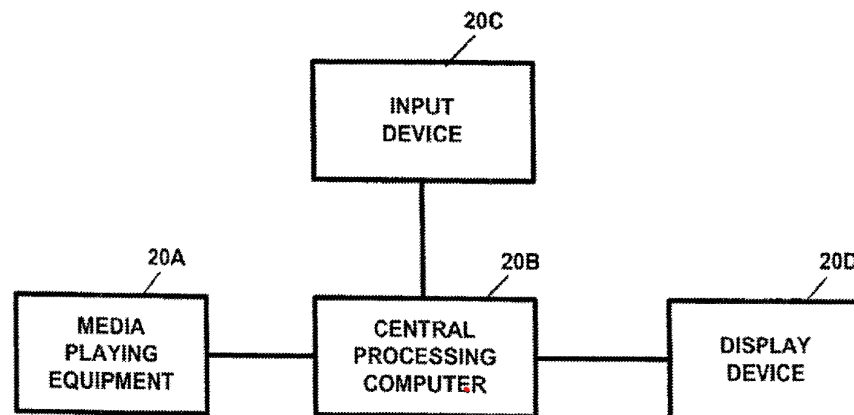

'016 Patent, Fig. 3. If one were attempting to illustrate a “generic environment in which to carry out” an “abstract idea,” or to draft an assembly of physical components without attempting to improve the use or configuration of such well-known conceptual devices, this drawing would serve adequately. By contrast, this figure—like all of the figures in the subject patent—fails to depict a patent-eligible idea, despite purporting to incorporate “concrete, tangible” components. And simply dubbing these components “wearable” or “wirelessly coupled” without providing any technical details—either in the specification or the diagrams—as to how this is to be achieved makes them no more patentable than any similarly empty designation, such as suggesting they be made submersible, heat resistant, or bulletproof.

The Complaint herein does nothing to alter this conclusion. Indeed, if anything, the generalized allegations of the Complaint reinforce the notion that Plaintiff’s claims exist in the realm of the abstract. Consider, for example, the allegation that “the ability of the claimed wearable content player to wirelessly couple with a remote control improves the operations of such wearable content player device by permitting it to be operated remotely, as well as to provide information associated with the content to the user on the remote control.” DE 1 at 7. The same assertion—that a remote control improves a device by allowing remote operation as well as the provision of additional information to the user—is equally true of an electronic thermostat, a video doorbell

system, a motorized garage door opener and countless other home devices. This kind of generalized allegation—without any suggestion as to how the so-called patented technology improves such a system—helps establish Defendants’ point: through the patent, and this suit, Plaintiff attempts to monopolize an abstract concept.

Plaintiff’s contention that the Asserted Patents do not pre-empt the “entire idea” of the abstract concept it is directed to, given the limitations set out in the claims, fares no better. Much like its arguments regarding the concrete nature of the claimed invention, Plaintiff’s arguments denying preemption “are unconvincing, as [Plaintiff] merely states that the claim ‘recites specific, narrowing limitations arranged in a particular manner.’” *ChargePoint*, 920 F.3d at 769; *see* DE 23 at 13 n.6 (arguing the claims are not abstract because they are “directed to an improved content player, with a specific combination of non-generic hardware components providing specific features”). “Even if [Plaintiff’s] specification had provided, for example, a technical explanation of how to enable” the provision of information in conjunction with media content, “which . . . it did not[], the claim language here would not require those details. Instead, the claim language here would cover any mechanism” for providing information in conjunction with media content, at least so long as that mechanism was wearable and could be controlled by another device with a display. *ChargePoint*, 920 F.3d at 769-70.

To be sure, this technically means that the claim language would not cover *any* content player capable of providing information alongside content. But it is immaterial that there are other ways of applying the abstract concept “without using the specific claimed content player/remote combination” addressed by the claims. DE 23 at 12. “[I]f a process application implements a principle in some specific fashion,” it does not “automatically fall[] within the patentable subject matter of § 101.” *Parker v. Flook*, 437 U.S. 584, 593 (1978). Merely “limiting an abstract idea to one field of use or adding token postsolution components [does] not make the concept patentable.” *Bilski*, 561 U.S. at 612. The mere recitation of, for example, a remote with a separate display—neither of which is given a technical explanation in the specification or is related to the solution addressed by the patent—does not make the abstract concept here patentable. “[A]lthough the claims limit the abstract idea to a particular environment”—here, a wearable content player with a paired remote featuring a separate display—“that does not make the claims any less abstract for the step 1 analysis.” *TLI Commc’ns*, 823 F.3d at 613; *see also Intellectual Ventures I LLC v. Symantec Corp.*, 838 F.3d 1307, 1321 (Fed. Cir. 2016) (“A narrow claim directed to an abstract



idea . . . is not necessarily patent-eligible, for “[w]hile preemption may signal patent ineligible subject matter, the absence of complete preemption does not demonstrate patent eligibility.”) (quoting *Ariosa Diagnostics, Inc. v. Sequenom, Inc.*, 788 F.3d 1371, 1379 (Fed. Cir. 2015)); *OIP Techs., Inc. v. Amazon.com, Inc.*, 788 F.3d 1359, 1362–63 (Fed. Cir. 2015) (“[T]hat the claims do not preempt all price optimization or may be limited to price optimization . . . in the e-commerce setting do not make them any less abstract.”).<sup>8</sup>

In conclusion, then, the components and their arrangement fail to present “a particular way of performing” the abstract idea of providing information in conjunction with media content. *Affinity Labs*, 838 F.3d at 1258. While they do set out a specific context for this abstract idea, there is nothing in the claim “that is directed to *how* to implement” the idea. *Id.* Rather, the claim limitations merely “confine the abstract idea to a particular technological environment—in this case,” wearable content players with remote control devices. *Id.* at 1258-59.

B. *Alice* Step Two: Whether the Claims Include an “Inventive Concept” Sufficient to “Transform the Nature of the Claim” into a Patentable Invention

Turning, then, to the second step in the *Alice* framework, “[t]he ‘inventive concept’ step” which requires the Court “to look with more specificity at what the claim elements add, in order to determine ‘whether they identify an “inventive concept” in the application of the ineligible subject matter’ to which the claim is directed.” *Affinity Labs*, 838 F.3d at 1257–58 (Fed. Cir. 2016). Defendants argue that “the claims’ recitation of well-known, conventional components – a receiver, a processor, memory, displays – used in their conventional manner, both individually and in combination, does not transform the claimed abstract idea into patentable subject matter.” DE 22 at 2, 15. Delving into the specification’s description of these components, Defendants contend that none present “technical advancements,” but that they are instead generic components with minimal limitations and no unique elements. *Id.* at 3-4, 12. Defendants claim that the patents do

---

<sup>8</sup> Plaintiff further contends that that the claims cannot be directed to an abstract concept as they “plainly cannot be practiced with pen and paper or in the human mind.” DE 23 at 12. But the only steps of the claim that cannot be so practiced are those involving remote control operation, which itself has been determined to be abstract. *See ChargePoint*, 920 F.3d at 766. Moreover, “the recitation of a practical application for the calculation [cannot] alone make the invention patentable,” as otherwise “any ‘competent draftsman could attach some form of post-solution activity to almost any [abstract idea].” *CyberSource Corp. v. Retail Decisions, Inc.*, 654 F.3d 1366, 1371 (Fed. Cir. 2011) (citing *Flook*, 437 U.S. at 590).

not “purport to use these conventional components in any new or inventive way, and the patents do not purport to have invented any new or improved technological process,” *id.* at 6, nor do they “claim that the components are . . . arranged in an unconventional manner,” *id.* at 15. “Instead,” Defendants argue, “the components are arranged in the exact manner one would expect to provide information to a person enjoying content – e.g., memory being coupled to a processor.” *Id.* at 15.

Additionally, Defendants compare the “purported advancement” of “providing information to a person *while* he or she enjoys content” to improvements in “computer-based efficiency” that failed to provide an inventive concept in other cases. *Id.* at 16 (emphasis added). While Defendants acknowledge the allegations in the Complaint as to the inventiveness of the Asserted Patents, Defendants dismiss these allegations as both conclusory and improperly addressed to novelty or obviousness under 35 U.S.C. §§ 102 and 103. *Id.* at 16-17.

Plaintiff responds that the Complaint “alleges specific facts supporting the inventiveness of the claims,” which bars dismissal at the pleadings stage. DE 23 at 1-2. According to Plaintiff, the Complaint presents “plausible and specific factual allegations regarding the inventive aspects of the claims” that bar the determination of eligibility at this stage. *Id.* at 14. Specifically, Plaintiff points to the allegation that the Asserted Patents are “directed to a specific improved content player,” which is “wearable” and requires “a display and playing device equipment” which is “configured to be ‘wirelessly coupled with a remote control having a second display’ that can ‘control the operation of the wearable content player.’” *Id.* (quoting DE 1 at 5; the Complaint further sets out that the remote control “can provide a user at least a portion of the information associated with the content on the wearable content player,” *id.*).

Plaintiff further argues that Defendants “fail to analyze the claims as an ordered combination” and ignore the factual allegations of the Complaint. DE 23 at 15, 17. Plaintiff reiterates the limitations noted above and contends that these limitations—as argued in the Complaint—“contain components that function in a specific manner, the combination of which is unique to the claims . . . and which are directed to improvements in content players,” thus making the claimed invention not “well-known, routine, or conventional at the time of the invention.” *Id.* at 15-16. Similarly, Plaintiff argues that “the claimed combination is unconventional” and that “the Complaint contains allegations to that effect,” allegations apparently ignored by Defendants. *Id.* at 17. Plaintiff points to the prosecution history of the Asserted Patents to point out, for example, that the claimed invention was distinguished over prior art because it is “wearable” and featured

“a remote control with a display for providing information about content.” *Id.* at 18-19. Plaintiff specifically responds to Defendants’ argument about the advancement of providing content “*along with* information regarding the content” by observing that the specification stated that, at the time of the invention, “no system or apparatus [was] currently available” which could do so. *Id.* at 19 (emphasis in original).<sup>9</sup>

The Court finds that “the claims fail to recite any elements that individually or as an ordered combination transform the abstract idea” of providing information in conjunction with media content “into a patent-eligible application of that idea.” *TLI Commc ’ns*, 823 F.3d at 613. The claims merely invoke conventional and generic components arranged in a conventional manner, which perform well-understood, routine activities. “[W]hile the specification and claims . . . purport to describe” an improved content player which allows for the ability to provide information in conjunction with media content, “the patent is wholly devoid of details which describe *how* this is accomplished.” *Interval Licensing*, 896 F.3d at 1346; *see also Affinity Labs*, 838 F.3d at 1258.

Plaintiff first argues that “the components recited in the claims cannot be ‘conventional’ within the meaning of . . . *Alice* absent fact-finding by the court.” *TLI Commc ’ns*, 823 F.3d at 613. Specifically, Plaintiff contends that the “plausible and specific factual allegations regarding the inventive aspects of the claims” set out in the Complaint bar determination of patent eligibility at the pleadings stage. DE 23 at 13-14. It is true that, as set out above, “plausible and specific factual allegations that aspects of the claims are inventive are sufficient” to defeat a motion to dismiss. *Cellspin*, 927 F.3d at 1317. However, as discussed further below, Plaintiff’s allegations of inventiveness are “mere conclusory statements” which may properly be disregarded. *Berkheimer II*, 890 F.3d at 1372 (Moore, J., concurring). To complete the eligibility analysis, then, the Court need not engage in “extraneous fact finding outside the record,” but “need . . . only look to the specification,” which describes the components “as either performing basic computer functions . . . or performing functions ‘known’ in the art.” *TLI Commc ’ns*, 823 F.3d at 614.

---

<sup>9</sup> In an effort to drive home the inventiveness of its claims, Plaintiff alleges that “the first watch that wirelessly paired with a cell phone, the Sony Ericsson MBW-100, was not released until 2006, approximately four years after the filing date of the original utility patent application to which the Patents-in-suit claim priority.” DE 1 at 8. Of course, Plaintiff’s patent discusses the wireless connection between a wearable content player and a remote control, and is not specifically related to the use of a smartphone in either capacity. Seen at this level of abstraction, it would appear that companies marketed watches in the early 1990s which were wirelessly tethered to a computer (like the Timex Datalink, released in 1994) as well as the Casio Wrist Remote, which could control televisions, VCRs and cable boxes. *See* Harry McCracken, *The Wrist of the Story: A Brief History of Forgotten Proto-Smartwatches, 1975-2004*, FAST COMPANY (Sept. 30, 2014), <https://www.fastcompany.com/3036368/the-wrist-of-the-story-a-brief-history-of-forgotten-proto-smartwatches-1975-2>.

Turning to the components recited in the claims, each component merely recites the “performance of ‘well-understood, routine, conventional activit[ies] previously known to the industry.’” *TLI Commc’ns*, 823 F.3d at 613 (quoting *Alice*, 573 U.S. at 225). As addressed above, the “media-playing device” (which encompasses both the “receiver” and the “playing device equipment” components) is defined as “any one or more of a radio, a television, a computer, a network terminal, a personal digital assistant (PDA)” and so forth. *See, e.g.*, ’016 Patent, col. 11 ll. 4-16. In other words, these components are defined entirely in terms of generic preexisting technology. The same is true for multiple other components. Specifically, the “processor” (or “central processing computer or central processing unit”) is defined as including “a processor[], a random access memory (RAM) device(s), read only memory (ROM) device(s) . . . and/or any other components or devices . . . for performing any of the functionality described herein.” *See, e.g., id.* at col. 12 ll. 55-62.<sup>10</sup> In turn, the “memory” (or “storage medium”) is defined as “a compact disc (CD), a digital video disc . . . (DVD), a video cassette, a laser disc,” and so forth. *Id.* at col. 5, ll. 25-32, col. 8 l. 63–col. 9 l. 4.<sup>11</sup> Consequently, all of these components “fall squarely within [Federal Circuit] precedent finding generic computer components insufficient to add an inventive concept to an otherwise abstract idea.” *TLI Commc’ns*, 823 F.3d at 614.

The other components are at best given cursory, functional descriptions. The “display” is defined merely as “a suitable display device” which “display[s] any of the information described-herein” and can be “a dedicated display device . . . [and/or] can be integrated into the . . . remote control display.” ’016 Patent, col. 4 ll. 27-30, col. 10 ll. 23-27, col. 15 ll. 17-21. Similarly, the “remote control device” is defined simply as a device “for inputting information and/or commands into the media-playing device” or “provid[ing] remote control over the operation of the media-playing device and/or the central processing computer . . . .” *Id.* at col. 4 ll. 24-30, col. 13 ll. 1-8. Meanwhile, the “wearable” nature of the content player is left undefined: the sole reference to the content player being wearable in the specification is to identify that, in one embodiment, the media-playing device “can be . . . a wearable computer display.” *Id.* at col. 16, ll. 54-58. The specification makes no reference *at all* to “wireless coupling” or pairing. Thus, in all cases, the specification

---

<sup>10</sup> The processor is otherwise described by its function, which is itself conventional: “process[ing] the information pertaining to the media content,” “control[ling] the display of same,” or “stor[ing] the information in a . . . memory device.” ’016 Patent, col. 12 ll. 62-65, col. 17 ll. 9-13.

<sup>11</sup> The memory is also defined in terms of its conventional function, that is, “storing any of the information described herein . . . [and] stor[ing] media content.” ’016 Patent, col. 4 ll. 13-18, col. 12 ll. 7-30.

“limits its discussion of the[] components to abstract functional descriptions devoid of technical explanation as to how to implement the invention.” *TLI Commc'ns*, 823 F.3d at 615. “Such vague, functional descriptions”—or indeed, lack of descriptions—“of [content player] components are insufficient to transform the abstract idea into a patent-eligible invention.” *Id.*

In short, none of the components provide an “inventive concept” sufficient to elevate the claims to being patent-eligible subject matter. Nor does Plaintiff present sufficient allegations of a “non-conventional and non-generic arrangement” of these conventional components. *BASCOM*, 827 F.3d at 1350. Plaintiff misinterprets *BASCOM* as holding that, where a claim recites conventional components, “recit[ing] a specific, discrete implementation of the abstract idea” *alone* is sufficient to provide the requisite inventive concept. DE 23 at 15. The fact that the specific combination of components is “unique to the claims of the Asserted Patents,” *id.*, is insufficient. Rather, critical to the determination in *BASCOM* was the fact that “the patent claimed and explained how a particular arrangement of elements was ‘a technical improvement over prior art . . . .’” *Amdocs (Israel)*, 841 F.3d at 1299 (quoting *BASCOM*, 827 F.3d at 1350). Thus, the “ordered combination” at issue in *BASCOM* provided an inventive concept because it established a “technology-based solution . . . that improve[d] the performance of the computer system itself.” *Id.* at 1298-99. Plaintiff similarly misconstrues the other cases it cites in support. For example, in *Aatrix*, the Federal Circuit found allegations in the complaint to “raise factual disputes” regarding an inventive concept because the complaint “describe[d] the development of the patented invention, including the problems present in prior art computerized form file creation.” 882 F.3d at 1126-27. The complaint there went on to “present[] specific allegations directed to ‘improvements and problems solved by the . . . patented inventions.’” *Id.* at 1127 (for example, “that the claimed software uses less memory, results in faster processing speed, and reduces the risk of thrashing which makes the computer process forms more efficiently.” *Id.*). Similarly, in *Cellspin*, the Federal Circuit reversed the district court’s dismissal because, in its complaint, the plaintiff specifically identified why prior art devices were “inferior,” and raised allegations “throughout the shared specification” that its solution to this issue, using a “two-step, two-device structure,” was “unconventional” and also “provided various benefits over prior art systems.” 927 F.3d at 1316-17. In sum, for the claims to identify an “inventive concept,” it is critical to assert *how* a particular arrangement of components improves upon the prior art and, in doing so, provides a technology-based solution to a problem unique to the field of the claimed invention. *See Aatrix*,

882 F.3d at 1127; *Amdocs (Israel)*, 841 F.3d at 1299; *Berkheimer I*, 881 F.3d at 1369; *Interval Licensing*, 896 F.3d at 1347.

Plaintiff's allegations in both the specification and the Complaint are insufficient to identify an inventive concept under these terms. As established above, the only asserted problem with the prior art identified in the specification was that of the failure to "provide . . . broadcasts along with information regarding the content of the respective broadcast." '016 Patent, col. 2 ll. 39-42. Yet the specification fails to identify how the arrangement of the conventional components is even *distinct* from the prior art, much less how it provides a technical improvement over the prior art that solves this problem.<sup>12</sup> In fact, the manner in which the claimed device accomplishes the asserted solution is described in terms that are just as open-ended as those that define the components. *See, e.g., id.* at col. 14 ll. 4-21 ("The information can be encoded and stored at the beginning of the respective audio file . . . and/or the information can be multiplexed with, and/or mixed with, the entire, or at least a portion of the, audio information . . . [or] the information can be broadcast along with the audio information . . ."); col. 14 ll. 51-56 ("[T]he information . . . can be transmitted as a header file to the song or selection of music . . . can be transmitted throughout the broadcast of the song or music selection, and/or . . . can be transmitted during a portion of the song or music selection."), col. 15 ll. 17-22 ("The information can be displayed on the display device . . . [or] can also be audibly announced through the radio speakers) and/or earphones."). The singular assertion in the specification that "no system or apparatus is currently available which can provide radio broadcasts or television broadcasts along with information regarding the content of the respective broadcast," *id.* at col. 2 ll. 39-42, though it must be accepted as true at this stage, is insufficient where "the patent is wholly devoid of details which describe *how* this is accomplished," *Interval Licensing*, 896 F.3d at 1346.<sup>13</sup> The allegations in the Complaint fail to alter this conclusion. The sole allegation regarding any technical improvement in this capability is

---

<sup>12</sup> Despite Plaintiff's argument to the contrary, the mere asserted capacity to present "the information associated with the content . . . together with the content," DE 23 at 20, cannot on its own provide the inventive concept, as this is the abstract concept itself. *See BSG Tech LLC v. Buyseasons, Inc.*, 899 F.3d 1281, 1290 (Fed. Cir. 2018) ("[A] claimed invention's use of the ineligible concept to which it is directed cannot supply the inventive concept that renders the invention 'significantly more' than that ineligible concept.).

<sup>13</sup> To be sure, in contrast to the claims at issue in *Interval Licensing*, the Asserted Patents *do* at least "describe how the second set of information is segregated from the primary set of information," i.e., through a second display incorporated into the remote control device. *Interval Licensing*, 896 F.3d at 1347. But the specification and Complaint fail to assert that this is even a distinction from the prior art, much less a meaningful one, nor does this address the issue that the patent fails to provide details on *how* to "provide radio broadcasts or television broadcasts along with information regarding the content of the respective broadcast."



that “the ability of the claimed wearable content player to wirelessly couple with a remote control improves the operations of such wearable content player device by permitting it . . . to provide information associated with the content to the user on the remote control.” DE 1 at 7. Not only does this merely restate the language in the claims, but it fails to address how the arrangement of the components is distinct from the prior art. As a result, the Complaint also fails to explain how this ability “improves” the content player.

As an alternative, Plaintiff argues that “the fact that the claimed device is ‘wearable,’” as well as the recitation of “a remote control that can both wirelessly control operations of a wearable content player, and provide a user with information about the content being played,” may each provide the requisite inventive concepts. DE 23 at 18-19. First, Plaintiff contends that Defendants fail to present evidence that such elements were conventional in 2002. However, even at the pleadings stage, the Court may properly examine the patent of its own accord to make this determination. *See Aatrix*, 882 F.3d at 1128. As established above, the specification describes these components only in conventional terms at best. While the language of claim 32 itself does further specify that the remote control device “compris[es] a second display” and “is configured to provide to the user at least a portion of the information associated with the content,” the specification fails to establish how this second display improves upon the prior art, or is in any way unconventional. In fact, “nothing in the patent contains any suggestion that the displays needed for that purpose are anything but readily available.” *Elec. Power Grp.*, 830 F.3d at 1355. The allegations in the Complaint fail to alter this conclusion, as they are merely conclusory or otherwise insufficient. For example, the Complaint alleges that the claimed inventions “were not well-known, routine, or conventional at the time of the invention . . . and represent specific improvements over the prior art,” and that “[t]he claimed technology . . . was not known in the prior art at the time of the invention.” DE 1 at 6-7. Such allegations, without more, are purely conclusory. The only substantive allegations in the Complaint are that “wearable computer devices that wirelessly paired with smartphones were not commercially available” at the time of the invention (specifically observing that “the first watch that wirelessly paired with a cellphone . . . was not released until 2006”),<sup>14</sup> and that “the ability of the claimed wearable content player to wirelessly couple with a

---

<sup>14</sup> While not critical to the determination here, it is worth noting that the relevant limitation of the claims is not directed to wireless pairing with a smartphone specifically, but with any remote control device that features a display. *See, e.g.*, '016 Patent col. 25 l. 25-col. 26 l. 3. As noted above, this capacity was conventional at the time of the invention. *See supra* note 9.



remote control improves the operations of such wearable content player device by permitting it to be operated remotely, as well as to provide information associated with the content to the user on the remote control.” *Id.* These allegations nevertheless fail to present an inventive concept because, once again, they entirely omit how these capabilities distinguish the claimed invention from the prior art, or how they present a technical solution to any identified problem in content players.

Second, Plaintiff attempts to justify these elements as unconventional by referring to the prosecution history of the Asserted Patents. *See* DE 23 at 18-20. However, the allowance of certain claims in the prosecution of the patent based on these limitations is not dispositive, as these allowances were based on novelty and obviousness determinations under 35 U.S.C. §§ 102 and 103, not eligibility determinations under § 101. *See Synopsys, Inc. v. Mentor Graphics Corp.*, 839 F.3d 1138, 1151 (Fed. Cir. 2016) (“Synopsys equates the inventive concept inquiry with novelty and contends that the Asserted Claims contain an inventive concept because they were not shown to have been anticipated by (35 U.S.C. § 102) or obvious over (35 U.S.C. § 103) the prior art. . . . That position misstates the law. . . . [A] claim for a *new* abstract idea is still an abstract idea.”); *Diamond v. Diehr*, 450 U.S. 175, 188–89 (1981) (“The ‘novelty’ of any element or steps in a process, or even of the process itself, is of no relevance in determining whether the subject matter of a claim falls within the § 101 categories of possibly patentable subject matter.”). The cases that Plaintiff cites in support of this line of reasoning are inapposite, as they refer to final written decisions by the Patent Trial and Appeal Board (“PTAB”) in inter partes review (“IPR”) proceedings, not to prosecution histories. *See Intellectual Ventures II LLC v. BITCO Gen. Ins. Corp.*, 362 F. Supp. 3d 370, 379 (E.D. Tex. 2019); *Ericsson Inc. v. TCL Commc'n Tech. Holdings, Ltd.*, No. 2:15-CV-00011-RSP, 2017 WL 5137401, at \*2, \*8 (E.D. Tex. Nov. 4, 2017). The distinction here is critical, as unlike in IPR proceedings that result in a final written decision, prosecution histories lack any written record in which the Patent & Trademark Office explicitly sets out its rationale for allowing plaintiff’s claims. Finally, the Court need not accept as true allegations that contradict the language of the patent itself. *See Secured Mail Sols.*, 873 F.3d at 913. Accordingly, the Court declines to give the prosecution history any weight in the eligibility determination at this juncture.

In conclusion, the Court finds that the claim limitations, whether considered individually or as an ordered combination, fail to present an “inventive concept” that “transform[s] the nature of the claim into a patent-eligible application.” *Alice*, 573 U.S. at 217 (quotations omitted). The

recited components are merely generic or otherwise nondescript, and Plaintiff raises no substantive allegations either in the specification or the Complaint to suggest that the arrangement of these components present “a technical solution to a problem unique to” content players, or that they provide “a technical improvement over prior art.” *BASCOM*, 827 F.3d at 1350-51; *Amdocs (Israel)*, 841 F.3d at 1299. Accordingly, the Court finds that the Asserted Patents are invalid as addressed to patent-ineligible subject matter, and hereby GRANTS Defendants’ motion to dismiss.

Moreover, the Court dismisses Plaintiff’s complaint with prejudice to amendment. A court “should not dismiss the complaint for failure to state a claim ‘unless it appears beyond doubt that the plaintiff can prove no set of facts in support of his claim which would entitle him to relief,’ and it should not deny leave to file a proposed amended complaint unless that same rigorous standard is met. *Ricciuti v. N.Y.C. Transit Auth.*, 941 F.2d 119, 123 (2d Cir. 1991) (quoting *Conley v. Gibson*, 355 U.S. 41, 45-46 (1957)). Federal Rule of Civil Procedure 15(a) “provides that leave to amend ‘shall be freely given when justice so requires,’ and it is rare that such leave should be denied, especially when there has been no prior amendment.” *Id.* (internal citations omitted). “Leave to amend need not be granted, however, where the proposed amendment would be ‘futil[e].” *Advanced Magnetics, Inc. v. Bayfront Partners, Inc.*, 106 F.3d 11, 18 (2d Cir. 1997) (quoting *Foman v. Davis*, 371 U.S. 178, 182 (1962)). Any amendment here would indeed be futile. As discussed above, the components are entirely generic, and the specification fails either to distinguish their arrangement from the prior art or to provide any explanation for how this arrangement provides a technical improvement over the prior art that solves some identified problem. To be sure, new allegations in an amended complaint may, in certain circumstances, solve this issue. *See Cellspin*, 927 F.3d at 1317 (“As long as what makes the claims inventive is recited by the claims, the specification need not expressly list all the reasons why this claimed structure is unconventional.”). But even were Plaintiff to attempt to, for example, “describe[] the development of the patented invention, including the problems present” in prior art content players, the Court can conceive of no way in which Plaintiff could “then present[] specific allegations directed to ‘improvements and problems solved by’” the patented invention. *Aatrix*, 882 F.3d at 1127. That is because the components and their arrangement—as described by the specification—are not specific enough to address any specific improvement or solution. As established above, “[t]here is nothing” in either the specification or the claims “that is directed to *how* to implement” the abstract concept of providing information in conjunction with media content. *Affinity Labs*,

838 F.3d at 1258. “[T]he specification limits its discussion of the[] components to abstract functional descriptions devoid of technical explanation as to how to implement the invention.” *TLI Commc’ns*, 823 F.3d at 615. “Such vague, functional descriptions of . . . components are insufficient to transform the abstract idea into a patent-eligible invention.” *Id.* The failure of the specification in this regard, which applies to all of the components identified in the claims of the Asserted Patents, cannot be remedied through new allegations in an amended complaint. Accordingly, Plaintiff’s Complaint is dismissed WITH PREJUDICE.

**SO ORDERED.**

Dated: Central Islip, New York  
November 19, 2020

/s/ Gary R. Brown  
GARY R. BROWN  
United States District Judge