

UNITED STATES DISTRICT COURT  
SOUTHERN DISTRICT OF NEW YORK

KOHLER CO.,

Plaintiff,

-against-

SIGNATURE PLUMBING SPECIALTIES  
LLC,

Defendant.

23-cv-9686 (AS)

OPINION AND ORDER

ARUN SUBRAMANIAN, United States District Judge:

**BACKGROUND**

Kohler and Signature are players in the market for kitchen and bathroom fixtures. Kohler sued Signature, claiming infringement of several design patents, tortious interference with prospective economic advantage, and unfair competition. Signature says that Kohler's case is meritless, and that the faucet-behemoth is using litigation as a cudgel to force a smaller rival out of business. While discovery proceeded for a while, eventually Signature pleaded with the Court to turn off the tap to see if Signature's pending motion for judgment on the pleadings would send this case down the drain. The Court agreed and stayed the case while it considered the motion. The Court has taken a close look, and for the reasons set forth below, Signature's motion is GRANTED IN PART and DENIED IN PART.

**LEGAL STANDARD**

The critical issue here is whether, considering Kohler's amended complaint, Dkt. 33, Signature's amended answer, Dkt. 36, and other materials that the Court is allowed to consider, the complaint states a claim for relief that is plausible on its face. *See Lively v. WAFRA Inv. Advisory Grp., Inc.*, 6 F.4th 293, 301, 305 (2d Cir. 2021). The Court may consider "the complaint, the answer, any written documents attached to them, and any matter of which the court can take judicial notice." *L-7 Designs, Inc. v. Old Navy, LLC*, 647 F.3d 419, 422 (2d Cir. 2011) (quoting *Roberts v. Babkiewicz*, 582 F.3d 418, 419 (2d Cir. 2009)).

**DISCUSSION****I. Willful Infringement (Counts I-V)**

Signature first argues that Kohler's amended complaint fails to plausibly allege willful infringement of any of the patents in suit. As to each of the asserted patents, the amended complaint's main allegation is that Signature had actual notice of the patents "since at least the filing of the [original] Complaint." Dkt. 33 ¶¶ 39, 52, 65, 76, 89.

So the question is whether Kohler’s service of the complaint is enough to base a claim of willful infringement from at least that point forward. (Just a note for the reader—whether Kohler can pursue willful infringement for the pre-suit period is of limited significance, given that the complaint doesn’t allege any notice of any kind of Kohler’s patents prior to September 2023, just two months before the complaint was filed and served.)

Signature points to cases holding that a plaintiff can’t point to a complaint as the basis of a willfulness case. *See, e.g., Hills Point Indus. LLC v. Just Fur Love LLC*, 2023 WL 8804046, at \*4 (D. Del. Dec. 20, 2023); *Kaufman v. Microsoft Corp.*, 2020 WL 364136, at \*4 (S.D.N.Y. Jan. 22, 2020); *iFIT Inc. v. Peloton Interactive, Inc.*, 2022 WL 609605, at \*2 (D. Del. Jan. 28, 2022). But none of these cases explains why a complaint detailing the circumstances of the defendant’s infringement isn’t enough to render any subsequent infringement willful, even if the defendant was acting innocently beforehand. In *Therabody, Inc. v. Tzumi Electronics LLC*, Magistrate Judge Lehrburger canvassed the law on the issue and noted that “[m]ost courts . . . hold that allegations of post-filing willful infringement in an amended complaint may support a claim for willful infringement.” 2022 WL 17826642, at \*10 (S.D.N.Y. Dec. 19, 2022) (citation omitted), *report and recommendation adopted by* 2023 WL 6387231, at \*22 (S.D.N.Y. Sept. 29, 2023). After reviewing the authorities on both sides, Judge Lehrburger found “more persuasive” the view that notice through a complaint suffices, particularly given the Federal Circuit’s and Supreme Court’s rejection of rigid standards for enhanced damages. *Id.* at \*12. The Court agrees with Judge Lehrburger.

So Kohler can pursue a case of willful infringement, at least for the period after Signature was served with the original complaint in this case.

## **II. Compliance with the Marking Statute (Counts I-V)**

Signature next argues that Kohler failed to allege compliance with the patent-marking statute. *See* 35 U.S.C. § 287(a) (requiring the marking of products and stating that a failure to do so forecloses damages prior to notice to the alleged infringer). But the amended complaint *does* allege compliance as of September 2023. *See, e.g.,* Dkt. 33 ¶ 21 (“Kohler has employed virtual marking for the Design Patents-in-Suit since at least September 2023.”); *id.* ¶¶ 40, 53, 77, 90 (alleging marking as of September 2023). Signature fails to explain why this isn’t enough. Marking isn’t subject to heightened pleading or any greater specificity than is normally required under Federal Rule of Civil Procedure 8(a) and *Bell Atlantic Corporation v. Twombly*, 550 U.S. 544 (2007). The amended complaint meets the standard.

Of course, if discovery shows that Kohler failed to meet the requirements, then Signature can challenge Kohler’s prayer for pre-suit damages (pre-suit damages, apparently, for just two months, given that Kohler claims that it marked its products as of September 2023, and the original complaint in this case was served in November 2023). But on the pleadings, with Kohler’s allegations accepted as true and with all inferences taken in Kohler’s favor, dismissal of this part of Kohler’s case would be improper.

### III. Infringement (Counts II-III)

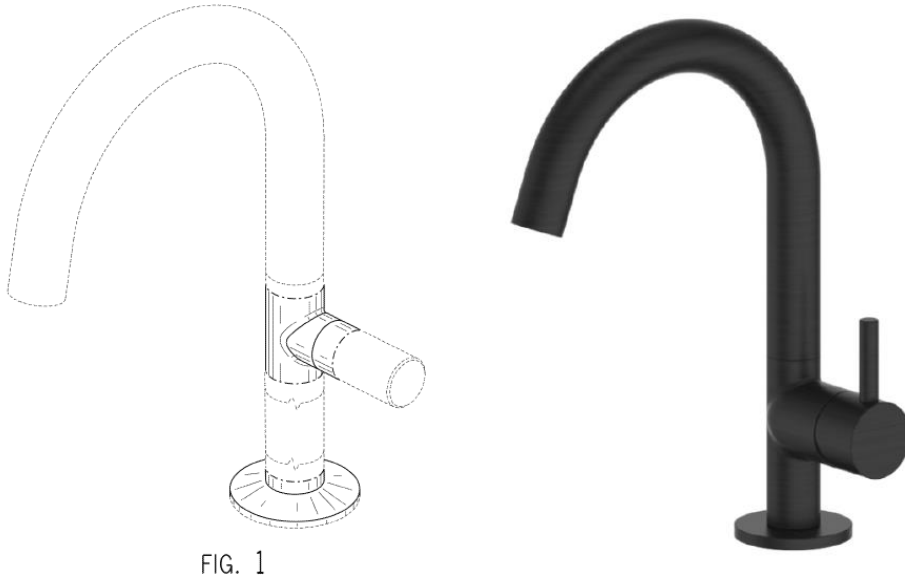
There are five asserted patents in this case. Signature alleges that Kohler has failed to plausibly allege infringement of two of them: the '988 and the '824 patents. Notably, as to each of these patents, Signature says that it *has never sold the faucets that are accused of infringement*. Dkt. 38 at 9, 11. Whether that's true or not remains to be seen and will be a question for summary judgment and trial.

To determine whether an accused product infringes a patented design, courts apply the “ordinary observer” test, that is, whether “an ordinary observer, familiar with the prior art designs, would be deceived into believing that the accused product is the same as the patented design.” *Anderson v. Kimberly-Clark Corp.*, 570 F. App'x 927, 933 (Fed. Cir. 2014) (quoting *Crocs, Inc. v. Int'l Trade Comm'n*, 598 F.3d 1294, 1303 (Fed. Cir. 2010)). “In some instances, the claimed design and the accused design will be sufficiently distinct that it will be clear without more that the patentee has not met its burden of proving the two designs would appear ‘substantially the same’ to the ordinary observer.” *Id.* (quoting *Egyptian Goddess, Inc. v. Swisa, Inc.*, 543 F.3d 665, 678 (Fed. Cir. 2008) (en banc)); *see, e.g., id.* at 933-34 (affirming dismissal of complaint where “plain differences exist between the accused products and the patented design” (citation omitted)); *Colida v. Nokia, Inc.*, 347 F. App'x 568, 571 (Fed. Cir. 2009) (agreeing that “the dissimilarities far exceed the similarities . . . and no amount of extrinsic evidence can change that” (citation omitted)).

“Differences . . . must be evaluated in the context of the claimed design as a whole, and not in the context of separate elements in isolation.” *Ethicon Endo-Surgery, Inc. v. Covidien, Inc.*, 796 F.3d 1312, 1335 (Fed. Cir. 2015). “Where . . . the claimed design includes several elements, the fact finder must apply the ordinary observer test by comparing similarities in overall designs, not similarities of ornamental features in isolation.” *Id.* “An element-by-element comparison, untethered from application of the ordinary observer inquiry to the overall design, is procedural error.” *Id.*

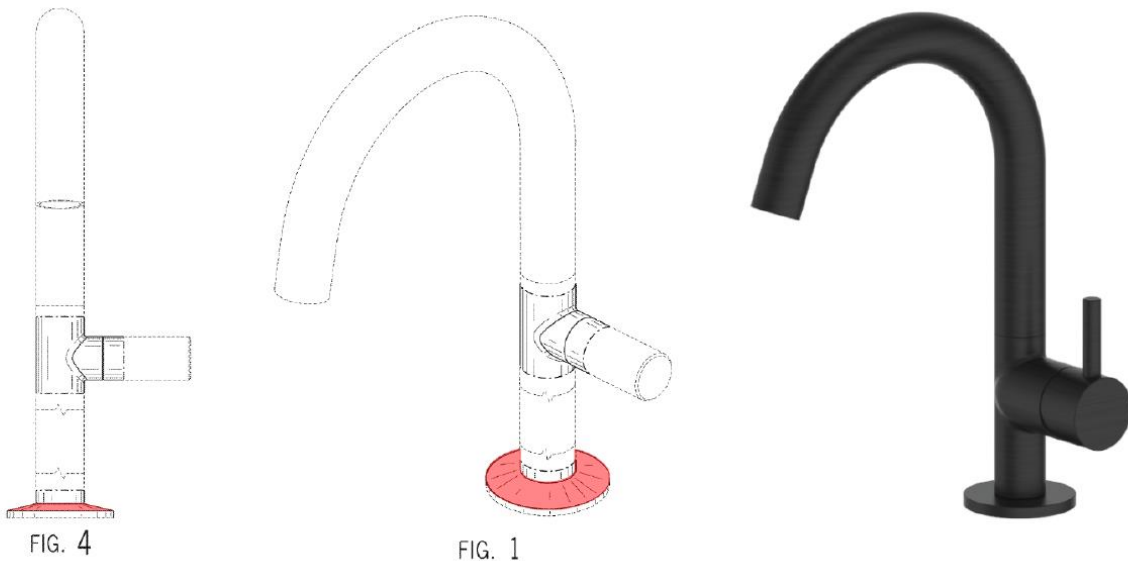
### A. The '988 Patent

Here's a side-by-side view of the design in the '988 patent versus the accused Signature faucet.



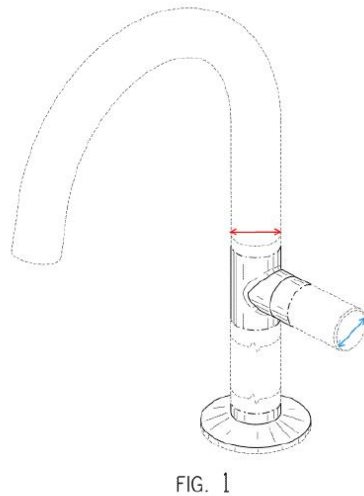
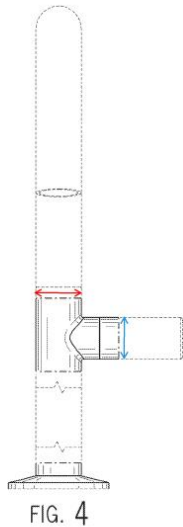
The parts of the faucet on the left that are patented *are in solid lines*, not dotted lines. So here, it's the solid portion of the handle, and the solid portion of the baseplate. Signature says that both features are plainly different, and that no ordinary observer could be deceived into believing that the design of its faucet was “substantially the same” as the patented design.

Signature's main argument is on the baseplate. Signature points out that in the '988 patent, the baseplate is pitched in an arched or dome-like shape, while in Signature's faucet, it's flat. Dkt. 38 at 9.



Signature argues that there's no plausible basis for a flat baseplate to infringe an arched or domed design. *Id.* at 10.

Second, Signature says that the patented design's handle has a horizontal portion with a diameter smaller than or equal to the diameter of the vertical portion. But in the accused faucet, says Signature, the horizontal portion has a larger diameter than the vertical portion. *Id.*



Signature says that for a design that has only two elements, where there are substantial differences between those elements and the accused product, there are plain differences that foreclose any claim of infringement. *Id.* at 11.

The Court agrees. While at a high level, both the claimed design and Signature's faucet include a handle and a baseplate, the Federal Circuit has made clear that "[s]imilarity at this conceptual level . . . is not sufficient to demonstrate infringement of the claimed designs." *Ethicon Endo-Surgery, Inc.*, 796 F.3d at 1336. "[B]ecause each of these components has a functional aspect, the underlying elements must be excluded from the scope of the design claims at this general conceptual level." *Id.* Instead, the question is whether there are plain dissimilarities when considering the "ornamental features of those components." *Id.*

The Court considers those features, the design as a whole, and the accused product. The most striking difference between the claimed design and the accused faucet is the baseplate. The design has a baseplate that is clearly arched or domed, while there is no dispute that the accused faucet's baseplate is flat. This isn't a question of whether Signature's baseplate is arched or domed enough to be substantially the same as the claimed design. It's just a different design. As for the handle, Signature correctly notes that the handle in its faucet is of a greater width than the vertical portion of the faucet, while the opposite is true in the claimed design.

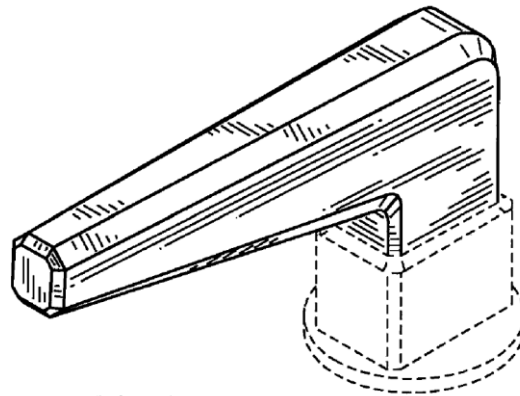
Considered from the vantage point of the ordinary observer, the design is plainly dissimilar from the accused faucet. Indeed, if this were not the case, many faucets with differing designs, but

which contain a handle and baseplate, would be arguably infringing. Kohler’s patent isn’t a license to corner the market on water faucets; instead, it protects a specific faucet design, one which Signature’s faucet is plainly distinct from.

Kohler doesn’t even engage with Signature’s arguments. It doesn’t respond to Signature’s specific contentions or contend that Signature’s descriptions of the design or the product are inaccurate. Kohler simply says that the pictures of the patented design and accused faucet look similar enough that there’s a fact question, even while Kohler acknowledges that the Court can, in an appropriate case, decide non-infringement on the face of the complaint. Dkt. 46 at 10. Kohler characterizes Signature’s claimed differences as “minute” and urges the Court to “view the design patent side-by-side the accused product.” *Id.* at 11. Even doing that, Kohler needs to have *some* explanation why marked differences between the accused product and the two patented elements of its design are insubstantial. Cases like *Ethicon* and *Anderson* make clear that even if the inquiry is based on the claimed design as whole, a court necessarily grapples with distinctions in the design’s elements. But Kohler decided not to engage. Its claim based on the ’988 patent is dismissed with prejudice.

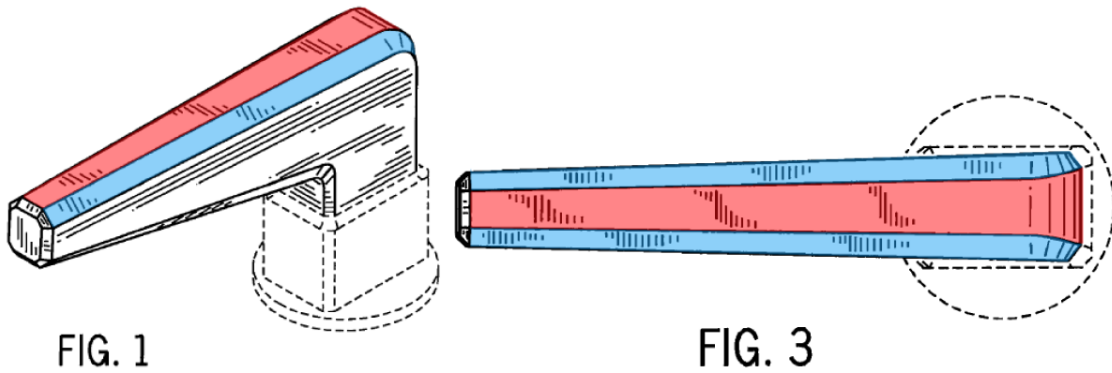
#### **B. ’824 Patent**

The design from the ’824 patent looks like this.

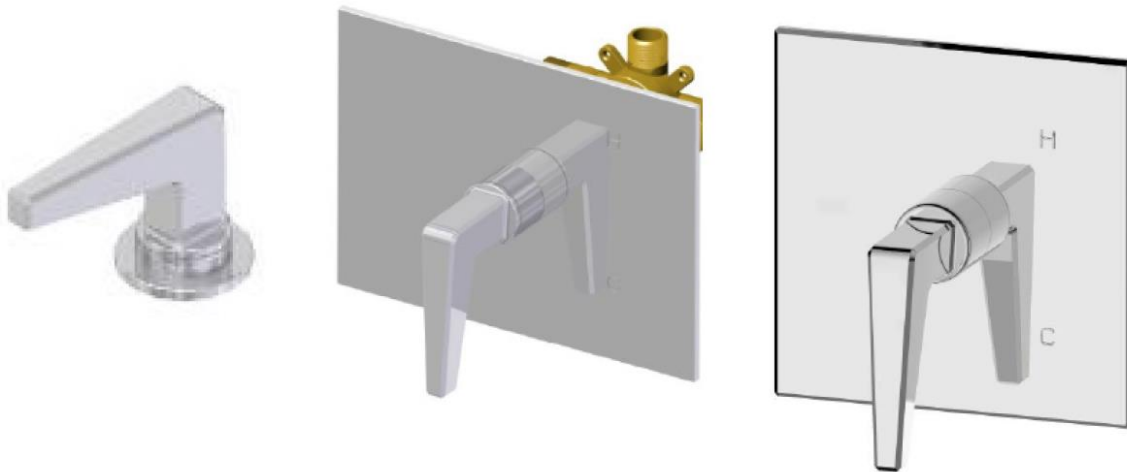


**FIG. 1**

Signature points out that this design has wide angled corners that form an octagon at the tip.



Signature says that the accused faucets have “linear, squared-off designs”:



In short, Signature says that its faucets, which cut a square profile, can’t be substantially the same as a design that cuts an octagonal profile. A square is not an octagon, says Signature. Dkt. 38 at 12.

Here, just as with the ’988 patent, the Court holds that the claimed design and Signature’s accused faucet are plainly dissimilar. The claimed design shows an octagon-shaped faucet with wide-cut sides. When viewed from the top, the faucet has three sides of substantially equal width. That is not Signature’s faucet, which has a square profile and a flat appearance when viewed in comparison to Kohler’s claimed design. At a fundamental level, the design and Signature’s accused faucets are different.

Once again, Kohler doesn’t engage. It just says that the claimed distinction is not “significant.” Dkt. 46 at 12. But conducting the analysis that Kohler urges—comparing the design to the accused faucets side-by-side—an octagon-shaped faucet is different from a square one. Of course, the design is for a faucet, and so as the Court recognized in *Ethicon*, there will be similarities in the functional aspects of the design and the product. But for a design patent, the focus is on the

ornamental aspects of the design, and here, the dominating feature of the design is its shape. That shape is fundamentally different from the shape of the accused faucets. Kohler's claim based on the '824 patent is dismissed with prejudice.

#### **IV. Prior Sales (Counts I, IV, and V)**

As for the '732, '614, and '487 patents, Signature does not challenge infringement at this juncture, but instead argues that the accused products were sold before the priority dates of the patents, which renders the patents invalid. Dkt. 38 at 14-18; *see Upsher-Smith Lab'ys, Inc. v. PamLab, L.L.C.*, 412 F.3d 1319, 1322 (Fed. Cir. 2005) ("A century-old axiom of patent law holds that a product 'which would literally infringe if later in time anticipates if earlier.'" (quoting *Schering Corp. v. Geneva Pharms., Inc.*, 339 F.3d 1373, 1379 (Fed. Cir. 2003))). Signature attached information relating to these prior sales to its amended answer. These documents, however, do not fall within the narrow category of documents that the Court can entertain at this stage.

"In determining the adequacy of a claim under Rule 12(b)(6), consideration is limited to facts stated on the face of the complaint, in documents appended to the complaint or incorporated in the complaint by reference, and to matters of which judicial notice may be taken." *Allen v. WestPoint-Pepperell, Inc.*, 945 F.2d 40, 44 (2d Cir. 1991); *see also Lively*, 6 F.4th at 305 (explaining that this same limitation applies on a Rule 12(c) motion). Signature points to images from real estate listings on the internet, which purportedly show Signature products installed in bathrooms, and Signature business records purportedly corroborating those prior sales. Dkt. 38 at 13. It says that the Court can take judicial notice of these materials. *Id.* But courts can take judicial notice only of facts that are "capable of accurate and ready determination by resort to sources whose accuracy cannot reasonably be questioned." *Island Software & Comput. Serv., Inc. v. Microsoft Corp.*, 413 F.3d 257, 261 (2d Cir. 2005); *see also* Fed. R. Evid. 201(b). Kohler says that "unauthenticated third-party webpage photographs, . . . purchase and packaging orders that lack pricing terms and critically fail to tether the referenced SKUs to the accused Signature products, an unauthenticated brochure, undated products specifications, and the self-interested declaration of Signature's president" are all sources whose accuracy is "subject to reasonable dispute." Dkt. 46 at 14 (citation omitted). The Court agrees, and even Signature seems to recognize that this is not the stuff of judicial notice, because in the alternative, it suggests that the Court should convert its motion for judgment on the pleadings into a motion for summary judgment under Federal Rule of Civil Procedure 12(d). Dkt. 38 at 14; Dkt. 47 at 4.

The Court sympathizes with Signature's desire to have a quick resolution of the question whether prior sales invalidate Kohler's patents, but the Court must work within the constraints of the rules. And the rules prohibit the Court from relying, right now, on the extrinsic materials that Signature says prove its invalidity defense. The Court declines to convert this motion into one for summary judgment and decide this issue now, given that doing so is appropriate "only in the rarest of cases." *William Gottlieb Mgmt. Co., LLC v. Carlin*, 2024 WL 1311854, at \*3 (S.D.N.Y. Mar. 26, 2024) (citation omitted). Kohler's failure to respond to Signature's statement of undisputed



material facts, which Signature submitted with its motion for judgment on the pleadings, does not make this such an exceptional case.

However, the Court will determine, based on the parties' presentation at the next hearing, whether discovery should proceed solely on the issue of these prior sales. And once any necessary discovery is complete, the Court will have a full record and can decide this issue under the usual summary-judgment standard. *See* Fed. R. Civ. P. 12(d) ("If . . . matters outside the pleadings are presented to and not excluded by the court, the motion must be treated as one for summary judgment under Rule 56. All parties must be given a reasonable opportunity to present all the material that is pertinent to the motion.").

## **V. State Law Counts Are Not Plausibly Alleged (Counts VI and VII)**

The amended complaint added two claims to this case, for tortious interference with prospective economic advantage and unfair competition under New York law. Both claims will be dismissed.

### **A. Tortious Interference with Prospective Economic Advantage**

"Under New York law, in order to make out a *prima facie* case for tortious interference with prospective economic advantage, a plaintiff must establish '(1) that [he] had a business relationship with a third party; (2) the defendant knew of that relationship and intentionally interfered with it; (3) the defendant acted solely out of malice, or used dishonest, unfair, or improper means; and (4) the defendant's interference caused injury to the relationship.'" *Friedman v. Coldwater Creek, Inc.*, 321 F. App'x 58, 59-60 (2d Cir. 2009) (alteration in original) (quoting *Kirch v. Liberty Media Corp.*, 449 F.3d 388, 400 (2d Cir. 2006)). "[A]s a general rule, a defendant's conduct must amount to a crime or an independent tort' in order to amount to tortious interference with a prospective economic advantage." *Id.* at 60 (quoting *Carvel Corp. v. Noonan*, 818 N.E.2d 1100, 1103 (N.Y. 2004)). "A defendant who has not committed a crime or independent tort or acted solely out of malice may nevertheless be liable if he has employed 'wrongful means.'" *Id.* "Wrongful means' include physical violence, fraud or misrepresentation, civil suits and criminal prosecutions, and 'extreme and unfair' economic pressure." *Id.* (first quoting *Guard-Life Corp. v. S. Parker Hardware Mfg. Corp.*, 406 N.E.2d 445, 449 (N.Y. 1980); and then quoting *Carvel*, 818 N.E.2d at 1105). But as the Court in *Friedman* made clear, not every misrepresentation will provide a basis for a claim for tortious interference with prospective economic advantage. 321 F. App'x at 60 ("The New York Court of Appeals has never held that *any* misrepresentation to a third party is sufficient to sustain a claim for tortious interference with prospective economic relations.").

Here, Kohler's pleading of its tortious-interference claim is woefully deficient. The claim is based on alleged misrepresentations made to customers, but the who, what, when, and where of the alleged conduct are specified in only the most generic terms. The amended complaint alleges that "[a]s a result of its business relationships, Kohler's products were initially selected to be used in a number of construction projects, hotels, and real estate developments," but that "Signature's products were ultimately sourced and used in these developments in place of Kohler's offerings."

Dkt. 33 ¶ 95. The complaint alleges on information and belief that “Signature’s representatives and/or agents pitch Signature’s products in lieu of Kohler’s previously selected or spec fixtures by making false statements to developers and designers that Signature’s products are the same as or substantially similar to Kohler’s products but at a deeply discounted price.” *Id.* ¶ 96. The amended complaint alleges, again on information and belief, that “Kohler products have been replaced on various projects in favor of Signature’s products as a direct result of Signature’s and its representatives’ and/or agents’ false and misleading statements.” *Id.* ¶ 97. The amended complaint doesn’t explain what statements were made, by whom, to whom, or relating to which specific products. Are they the products at issue on Kohler’s patent claims? Because if so, how can Kohler on the one hand plausibly allege the products’ designs are in fact substantially similar, but on the other hand claim that such statements were misrepresentations? Kohler gives this argument a shrug, merely saying that “Kohler’s assertions need not be mutually exclusive,” Dkt. 46 at 8, and that “[a] product can infringe a design patent and not be made of the same quality or to [sic] with the same degree of craftsmanship’s as those of Kohler’s.” *Id.*

And who made these statements? Who knows. When and where were these statements made? Unknown. There’s a paragraph in the amended complaint that lists developments that Kohler claims it had “business relationships” with, Dkt. 33 ¶ 94, but the complaint doesn’t connect the dots to say that it’s these specific projects as to which the chicanery took place. Kohler cites no case approving a tortious-interference claim on allegations like those in the amended complaint. In fact, Kohler doesn’t cite a single authority suggesting that a competitor can be held liable for tortious interference for trying to convince customers that their products are “substantially similar” to a higher-priced model but a better deal for the customer. One would think that this is the stuff of normal competition. What’s missing is what the law requires: a plausible, *Twombly*-compliant allegation that “wrongful means” were employed in attempts to secure this business.

## **B. Unfair Competition**

“To state a claim for the misappropriation theory of unfair competition, a plaintiff must allege that the defendant: (1) misappropriated the plaintiff’s labors, skills, expenditures, or good will; and (2) displayed some element of bad faith in doing so.” *CDC Newburgh Inc. v. STM Bags, LLC*, 692 F. Supp. 3d 205, 226 (S.D.N.Y. 2023) (cleaned up) (quoting *Barbagallo v. Marcum LLP*, 820 F. Supp. 2d 429, 446 (S.D.N.Y. 2011)).

The allegations in the complaint on the unfair-competition claim are similar to those on the tortious-interference claim. The amended complaint alleges that “Kohler expended a substantial amount of skill and labor designing its suite of products and pitching the same to developers and designers associated with construction projects, hotels, and real estate developments in and around New York City, among other places.” Dkt. 33 ¶ 101. It further alleges, on information and belief, that “Signature’s representatives and/or agents gather information related to the selection of plumbing-related fixtures,” including where Kohler products “have been selected,” and then “pitch Signature’s products in lieu of Kohler’s previously selected or spec fixtures by making false statements to developers and designers that Signature’s products are the same as or substantially

similar to Kohler’s products but at a deeply discounted price.” *Id.* ¶ 102. The amended complaint alleges, again on information and belief, that Kohler products have been replaced on “various projects in favor of Signature’s products as a direct result of” these “false and misleading statements.” *Id.* ¶ 103. Finally, once more on information and belief, the amended complaint says that “Signature copied Kohler’s product designs in bad faith and misappropriated Kohler’s expenditure of skill and labor as well as Kohler’s reputation and goodwill in offering the Signature copycats to developers and designers with false representations that the Signature products are the same as or substantially similar to Kohler’s products.” *Id.* ¶ 104.

Just like the tortious-interference claim, Kohler cites no analogous cases and there is no detail as to the specifics of this claim. Even if this is an offshoot of Kohler’s patent claims, that doesn’t address the required element of “bad faith.” The complaint fails to lay out any of the details: the projects, the people involved, the false or misleading statements, anything. This plainly doesn’t suffice under *Twombly*. The unfair-competition claim is dismissed.

### **C. The Tortious-Interference and Unfair-Competition Claims are Dismissed with Prejudice**

The tortious-interference and unfair-competition claims were added to this case in the amended complaint. That was way back on March 15, 2024. Dkt. 33. After that happened, Signature filed a motion for judgment on the pleadings on March 29, 2024, Dkt. 37, which directly argued that the factual allegations underlying the tortious-interference and unfair-competition claims were deficient. Kohler made no application to amend those claims in light of Signature’s arguments and doesn’t even do so now. When the Court stayed the case, there were only six weeks left in the fact discovery period, and as of that time, no application had been made to amend. *See* Dkts. 51, 61. Under the circumstances, there is no basis to give Kohler another crack at amending its pleadings. *See Smith v. Manhattan Club Timeshare Ass’n, Inc.*, 944 F. Supp. 2d 244, 257-58 (S.D.N.Y. 2013) (denying leave to amend where plaintiff “failed to request leave to amend in a timely fashion”); *In re GPC Biotech AG Sec. Litig.*, 2009 WL 5125130, at \*4 (S.D.N.Y. Dec. 29, 2009) (denying leave to amend where “[d]efendants notified plaintiffs of the inaccuracies in the complaint on at least five occasions via letter before plaintiffs sought leave to amend”). Instead, what seems clear based on Kohler’s anemic allegations and briefing in support of these claims, is that they were tossed into the case as an afterthought once Signature had lodged significant challenges to Kohler’s patent claims. The claims are dismissed with prejudice.

## CONCLUSION

For the foregoing reasons, Signature's motion for judgment on the pleadings is GRANTED IN PART and DENIED IN PART. The Clerk of Court is respectfully requested to terminate the motion at Dkt. 37.

SO ORDERED.

Dated: November 25, 2024  
New York, New York

A handwritten signature in black ink, appearing to read 'Arun Subramanian', written over a horizontal line.

ARUN SUBRAMANIAN  
United States District Judge