

IN THE UNITED STATES DISTRICT COURT  
FOR THE MIDDLE DISTRICT OF NORTH CAROLINA

ULTIMATE HOME PROTECTOR )  
PANS, INC., d/b/a DRIPTITE, )  
 )  
Plaintiff, )

v. )

1:19CV280

CAMCO MANUFACTURING, INC., )  
HAIER US APPLIANCE OPERATION, )  
LLC, and HAIER US APPLIANCE )  
SOLUTIONS, INC., )  
 )  
Defendants. )

---

ULTIMATE HOME PROTECTOR )  
PANS, INC., d/b/a DRIPTITE, )  
 )  
Plaintiff, )

v. )

1:19CV675

HAIER US APPLIANCE OPERATION, )  
LLC, and HAIER US APPLIANCE )  
SOLUTIONS, INC., )  
 )  
Defendants. )

**MEMORANDUM OPINION AND ORDER**

**OSTEEN, JR., District Judge**

This matter is before the court on the motion to dismiss or transfer filed by Defendants Haier US Appliance Operation, LLC, and Haier US Appliance Solutions, Inc. (together, "GE Appliances"). (1:19CV675 (Doc. 7).) Also pending before the

court is a motion to dismiss filed by Camco Manufacturing, Inc. ("Camco"). (1:19CV280 (Doc. 8).)<sup>1</sup> For the reasons set forth herein, the court will deny Defendants' motions.

**I. FACTUAL AND PROCEDURAL BACKGROUND**

The facts, taken in the light most favorable to Plaintiff, are as follows.

**A. Factual Background**

**1. Parties**

Plaintiff is a corporation organized under the laws of the State of Nevada with its principal place of business in Ohio. (1:19CV280, Complaint ("Compl.") (Doc. 1) ¶ 2.) It develops and sells "various washer overflow pans, drip pans, leak pans or other similar products designed to protect residential dwelling from water damage and mold damage caused by dripping or leaking plumbing." (Id.) It owns U.S. Patent No. 8,393,351 (the "'351 Patent"), titled "Dual Automatic Dryer and Washing Machine Protective Basin." (Id. ¶ 1-2; Ex. A, Patent No. US 8,393,351 (Doc. 1-1) at 2.)

---

<sup>1</sup> On August 12, 2019, the cases (1:19CV280 and 1:19CV675) were consolidated and 1:19CV280 was designated as the lead case. (See Order 1:19CV280 (Doc. 18); Order 1:19CV675 (Doc. 25).) Citations to the record refer to the 1:19CV280 docket, unless otherwise noted.

Defendant Camco is a corporation organized under the laws of North Carolina with its principal place of business there as well. (Id. ¶ 3.)

Defendant Haier US Appliance Operation, LLC, is a limited liability company organized under the laws of Delaware with its principal office located in Kentucky. (1:19CV675, Verified Complaint (“Verified Compl.”) (Doc. 1) ¶ 3.) Defendant Haier US Appliance Solutions, Inc., is a corporation organized under the laws of Delaware with its principal place of business in Kentucky. (Id. ¶ 4.) Haier US Appliance Solutions, Inc., is the “sole member and parent company” of Haier US Appliance Operation, LLC. (Id.)

## **2. The '351 Patent**

The '351 Patent is entitled “Dual Automatic Dryer and Washing Machine Protective Basin,” and describes the invention as “a drip pan sized to fit both a washer and dryer, and to contain leakage from both appliances.” (1:19CV280, Compl., '351 Patent (Doc. 1-1) Ex. A at 2.) With the Protective Basin, “[t]he position of the washer and dryer can safely be swapped, and the pan can optionally be provided with an opening directly over a floor drain, which now need not be located under the washing machine.” (Id.) Further, “[t]he front wall of the basin can be sized to clear a door or pedestal drawer; alternatively, the

basin can have raised spots supporting the feet of the appliance or pedestal, so as to lift doors or drawers above the front wall." (Id.) The invention is depicted as Figure 1, '351 Patent (Doc. 1-1) at 3):

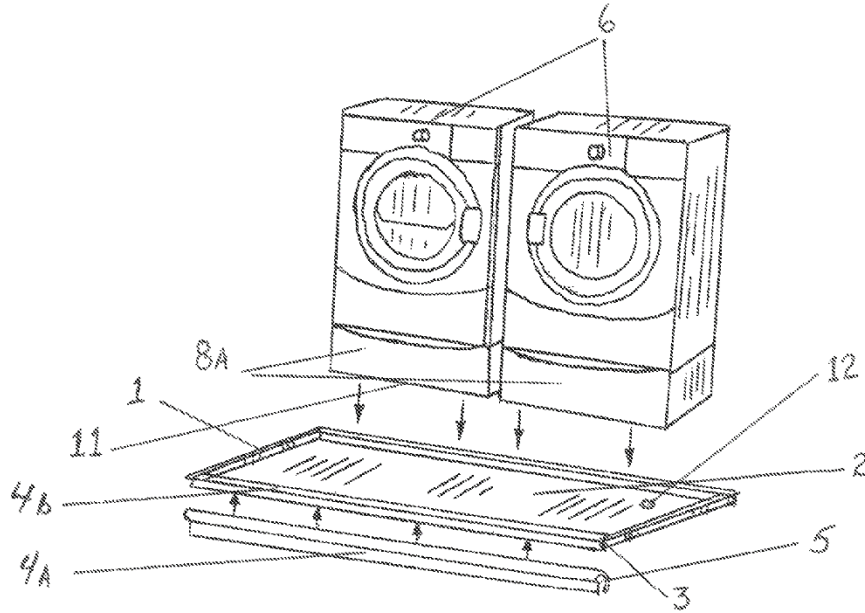

In the "Background of the Invention" the '351 Patent states that the Protective Basin "protects both dryer and washing machine and the underlying surface on which they are supported from drippage, and is effective with both front and top loaders installed side-by-side." (Id. at 8.) The '351 Patent recites seventeen claims for the invention. Claim 6, at issue here, reads:

6. A system for collecting leakages from at least one washing machine and at least one dryer, the system comprising:

a plurality of opposing side walls engaging with a front wall, a rear wall and a substantially flat bottom panel to define a basin structure having a void interior, said basin structure being sized to contain at least one washing machine and at least one dryer and being capable of containing liquid;

and at least one safety edge and/or safety corner adapted to engage with one or more top edges of the plurality of opposing side walls, the front wall and the rear wall;

whereby the at least one safety edge and/or safety corner provides thicker material and is formed to not be sharp-edged, both to provide greater strength to the wall top edges and to pose less danger to users.

(Id. at 11 (emphasis added).)

### **3. Defendants' Products**

Plaintiff alleges Camco "makes, uses, offers to sell . . . [at least three] washing machine drain pans that infringe one or more claims of the '351 Patent." (1:19CV280, Compl. (Doc. 1) ¶ 11.)<sup>2</sup> Camco sells these products on its website, on Amazon.com, and at other retail outlets like Lowe's Home Centers. (Id.)

Plaintiff also alleges Defendants Haier US Appliance Operation, LLC, and Haier US Appliance Solutions, Inc. (together, "GE Appliances") sell an infringing product titled

---

<sup>2</sup> Plaintiff lists Item #20786, Item #20787, and Item #20788 as examples of the infringing products. (1:19CV280, Compl. (Doc. 1) ¶ 11.)

the "Low Profile Universal Washing Machine Flood Tray."

(1:19CV675, Verified Compl. (Doc. 1) ¶ 16.)

Plaintiff alleges Defendants' products infringe "at least claim 6" of the '351 Patent. (Id. ¶ 17; 1:19CV280, Compl. (Doc. 1) ¶ 12.)

**B. Procedural Background**

Plaintiff brought suit against Camco in this court. (1:19CV280, Compl. (Doc. 1).) Camco filed a motion to dismiss, (Doc. 8), and a brief in support of its motion to dismiss. ("Camco's Br.") (Doc. 10).) Plaintiff responded, ("Pl.'s Camco Resp.") (Doc. 15)), and Camco replied. ("Camco's Reply") (Doc. 16).)

Plaintiff also brought suit against GE Appliances in the Western District of Kentucky. (1:19CV675, Verified Compl. (Doc. 1).) GE Appliances moved to dismiss or transfer the case to this district, (GE Appliances' Mot. (Doc. 7)), and the parties agreed to transfer the Complaint to this court. (Doc. 17.) Once transferred, the parties moved to consolidate the two cases, (1:19CV280 (Doc. 17); 1:19CV675 (Doc. 24), which the court granted. (1:19CV280 (Doc. 18); 1:19CV675 (Doc. 25).) Plaintiff responded to GE Appliances' motion, ("Pl.'s GE Appliances Resp.") (Doc. 19)), and GE Appliances replied, (Doc. 20).

## II. STANDARD OF REVIEW

To survive a Rule 12(b)(6) motion, "a complaint must contain sufficient factual matter, accepted as true, to 'state a claim to relief that is plausible on its face.'" Ashcroft v. Iqbal, 556 U.S. 662, 678 (2009) (quoting Bell Atl. Corp. v. Twombly, 550 U.S. 544, 570 (2007)). A claim is plausible on its face if "the plaintiff pleads factual content that allows the court to draw the reasonable inference that the defendant is liable" and demonstrates "more than a sheer possibility that a defendant has acted unlawfully." Iqbal, 556 U.S. at 678 (citing Twombly, 550 U.S. at 556-57). When ruling on a motion to dismiss, this court accepts the complaint's factual allegations as true. Iqbal, 556 U.S. at 678. Further, this court liberally construes "the complaint, including all reasonable inferences therefrom, . . . in plaintiff's favor." Estate of Williams-Moore v. All. One Receivables Mgmt., Inc., 335 F. Supp. 2d 636, 646 (M.D.N.C. 2004) (citation omitted). This court does not, however, accept legal conclusions as true, and "[t]hreadbare recitals of the elements of a cause of action, supported by mere conclusory statements, do not suffice." Iqbal, 556 U.S. at 678.

The court may consider the complaint's attachments as well as documents "attached to the motion to dismiss, so long as they are integral to the complaint and authentic." Sec'y of State for

Defence v. Trimble Navigation Ltd., 484 F.3d 700, 705 (4th Cir. 2007). The court may also take judicial notice of items in the public record, Hall v. Virginia, 385 F.3d 421, 424 n.3 (4th Cir. 2004), including patent and trademark registrations. Zinner v. Olenych, 108 F. Supp. 3d 369, 377 n.2 (E.D. Va. 2015).

### **III. ANALYSIS**

Determining patent infringement involves a two-step analysis. Carroll Touch, Inc. v. Electro Mech. Sys., Inc., 15 F.3d 1573, 1576 (Fed. Cir. 1993). First, a court must construe the claim at issue in order to determine its scope and meaning, as a matter of law. Id. Second, the court must compare the claim to the alleged infringer's products. Id.; see also ZMI Corp. v. Cardiac Resuscitator Corp., 844 F.2d 1576, 1578 (Fed. Cir. 1988).

Direct infringement occurs where "all steps of a claimed method are performed by or attributable to a single entity." Akamai Techs., Inc. v. Limelight Networks, Inc., 797 F.3d 1020, 1022 (Fed. Cir. 2015). A plaintiff may prove direct infringement by proving literal infringement or infringement under the doctrine of equivalents. Cross Med. Prods., Inc. v. Medtronic Sofamor Danek, Inc., 424 F.3d 1293, 1310 (Fed. Cir. 2005).

Literal infringement is found if the accused products embody every limitation of the claim. Carroll Touch, 15 F.3d at



1576. By contrast, under the doctrine of equivalents, "a product or process that does not literally infringe upon the express terms of a patent claim may nonetheless be found to infringe if there is 'equivalence' between the elements of the accused product or process and the claimed elements of the patented invention." Warner-Jenkinson Co. v. Hilton Davis Chem. Co., 520 U.S. 17, 21 (1997).

Plaintiff alleges Defendants infringed the '351 Patent under either literally or under the doctrine of equivalents. (1:19CV280, Compl. (Doc. 1) ¶¶ 12-13, 15-18; 1:19CV675, Verified Compl. (Doc. 1) ¶ 25). In particular, Plaintiff alleges Defendants infringed Claim 6 of the '351 Patent. (1:19CV280, Compl. (Doc. 1) ¶¶ 12-13; 1:19CV675, Verified Compl. (Doc. 1) ¶ 25.) Plaintiff also brings a claim for willful infringement against GE Appliances. (1:19CV675, Verified Compl. (Doc. 1) ¶¶ 29-32.)<sup>3</sup>

In their motions, Defendants argue that Plaintiff cannot state a claim for literal patent infringement "because none of the allegedly infringing products are sized to contain at least one washing machine and at least one dryer." (Camco's Br. (Doc.

---

<sup>3</sup> GE Appliances does not address Plaintiff's willful infringement claim in its motion. (See 1:19CV675, (Doc. 7).)

10) at 10 (internal quotation marks omitted); GE Appliances' Mot. (Doc. 7) at 5-6).)

Defendants further argue that Plaintiff cannot state a claim for infringement under the doctrine of equivalents due to the size limitations of the drip pans at issue. (Camco's Br. (Doc. 10) at 11-12; GE Appliances' Mot. (Doc. 7) at 7-8.) Defendants argue specifically that the patent prosecution history of the '351 Patent bars the application of the doctrine of equivalents and requires dismissal of Plaintiff's claims. (Camco's Br. (Doc. 10) at 11-12; GE Appliances' Mot. (Doc. 7) at 7-8.)

The court will address Plaintiff's literal and doctrine-of-equivalents infringement claims in turn

**A. Literal Infringement**

"To prove literal infringement, the patentee must show that the accused device contains every limitation in the asserted claims." Leggett & Platt, Inc. v. Hickory Springs Mfg. Co., 285 F.3d 1353, 1358 (Fed. Cir. 2002) (quoting Mas-Hamilton Grp. v. LaGard, Inc., 156 F.3d 1206, 1211 (Fed. Cir. 1998)).

Defendants argue that "Plaintiff fails to state a claim for literal patent infringement because none of the allegedly infringing products are 'sized to contain at least one washing machine and at least one dryer.'" (Camco's Br. (Doc. 10) at 10);

see also GE Appliances' Mot. (Doc. 7) at 6.) In response, Plaintiff, citing Camco's motion, argues that the allegedly infringing products "are sized to, and in fact designed to, contain at least one washing machine and at least one dryer if those appliances were in a stacked configuration." (Pl.'s Camco Resp. (Doc. 15) at 14.)<sup>4</sup> Plaintiff argues that, because "Claim 6's limitations are met literally by an accused product that is designed to fit a stackable washer and dryer, and since Camco has admitted that at least one of the Accused Products is designed for that purpose, Camco literally infringes at least Claim 6 of the '351 Patent." (Id. at 16.)

The court finds that this argument is premature because it would require the court to engage in claim construction. Claim construction is inappropriate at the motion to dismiss stage when there is a "subsidiary fact" in dispute; that is, a fact resulting in a dispute over how a person of ordinary skill in the art would understand the term. See Teva Pharm. USA, Inc. v. Sandoz, Inc., 574 U.S. 318, \_\_\_\_\_, 135 S. Ct. 831, 841 (2015). If there is such a fact at issue, the issue is premature and the court should wait to engage in claim construction or hold a

---

<sup>4</sup> In responding to GE Appliances' motion to dismiss, Plaintiff incorporated by reference its analysis contained in its response to Camco, (Pl.'s Camco Resp. (Doc. 15)). (Pl.'s GE Appliances Resp. (Doc. 19) at 3.)

claim construction hearing.<sup>5</sup> See id. at \_\_\_, 135 S. Ct. at 837-38]; Gebo Cermex USA Inc. v. All. Indus. Corp., Case No. 6:18-cv-00080, 2019 WL 2330905, at \*3 (W.D. Va. May 31, 2019).

The court finds that claim construction would be inappropriate at this stage of litigation, because there is a conflict as to what “at least one washing machine and at least one dryer” means. See Teva Pharm. USA, 574 U.S. at \_\_\_\_, 135 S. Ct. at 837-38; Nalco Co. v. Chem-Mod, LLC, 883 F.3d 1337, 1349 (Fed. Cir. 2018) (categorizing the defendants’ objections to the plaintiff’s allegations as objections to the plaintiff’s proposed claim construction, “a dispute not suitable for resolution on a motion to dismiss”). The court will therefore deny Defendants’ motions to dismiss Plaintiff’s literal infringement claims.

#### **B. Doctrine of Equivalents**

The Supreme Court has made clear that the doctrine of equivalents must be applied in a precise manner, holding that “[e]ach element contained in a patent claim is deemed material to defining the scope of the patented invention, and thus the

---

<sup>5</sup> In Markman v. Westview Instruments, Inc., 517 U.S. 370 (1996), the Supreme Court clarified which issues in a patent case are properly reserved for the jury, and which are questions of law to be determined by the court. Specifically, the Court held that interpretation of language in patent claims “is an issue for the judge, not the jury[.]” Id. at 391.

doctrine of equivalents must be applied to individual elements of the claim, not to the invention as a whole.” Warner-Jenkinson Co., 520 U.S. at 29. The court therefore “must consider each element of the allegedly infringed claim to determine whether there is equivalence between each of those elements and the accused device or method.” N5 Techs. LLC v. Capital One N.A., 56 F. Supp. 3d 755, 760 (E.D. Va. 2014). “If there is not equivalence between the accused device or method and any one element of the patent claim in issue, then there is no infringement under the doctrine of equivalence.” Id. at 760-61.

However, “[p]rosecution-history estoppel limits the application of the doctrine of equivalents.” Power Integrations, Inc. v. Fairchild Semiconductor Int’l, Inc., 904 F.3d 965, 975 (Fed. Cir. 2018). Prosecution-history estoppel provides that “[i]f a patentee surrenders certain subject matter during prosecution, the patentee is then barred from using the doctrine of equivalents to recover for infringement based on that same subject matter.” Id. (citing Festo Corp. v. Shoketsu Kinzoku Kogyu Kabushiki Co., 535 U.S. 722, 733-34 (2002)). Defendants argue that prosecution-history estoppel bars Plaintiff from succeeding on its infringement claim under the doctrine of equivalents. (Camco’s Br. (Doc. 10) at 11-12; GE Appliances’ Br. (Doc. 7) at 7-8.)

However, the court will likely need to consider the file wrapper of the '351 Patent in order to conduct a prosecution-history estoppel analysis.<sup>6</sup> But Plaintiff did not reference the file wrapper in the complaints and therefore the file wrapper may not be considered at this stage of the proceedings without converting Defendants' motions into motions for summary judgment. See E.I. du Pont de Nemours & Co. v. Kolon Indus., Inc., 637 F.3d 435, 448-49 (4th Cir. 2011). The court declines to convert the motions and therefore will not consider the file wrapper of the '351 Patent in ruling on the pending motions. See Philips v. Pitt Cty. Mem'l Hosp., 572 F.3d 176, 180 (4th Cir. 2009) (finding that courts may consider the pleadings, matters of public records, "as well as [documents] attached to the motion to dismiss, so long as they are integral to the complaint and authentic"); Par Pharm., Inc. v. Hospira, Inc., Civil Action No. 17-944-JFB-SRF, 2018 WL 3343238, at \*2 (D. Del. May 11, 2018) (declining to consider a patent's file history on a motion to dismiss); Kyowa Hakka Bio, Co. v. Ajinomoto Co., Civil Action No. 17-313, 2018 WL 834583, at \*6 (D. Del. Feb. 12, 2018) (same).

---

<sup>6</sup> "The 'file wrapper' connotes the official record of the case within the Patent & Trademark Office, including amendments and arguments submitted by the applicant." John Gladstone Mills III et al., Patent Law Fundamentals § 20:50 (2d ed. 2020).

The court also finds that to conduct an analysis of the prosecution history of the '351 Patent file wrapper would require the court to engage in claim construction, which the court has already found would be inappropriate at this stage of litigation. See Iris Corp. Berhad v. United States, No. 15-175C, 2019 WL 2317143, at \*1 (Fed. Cl. May 8, 2019) (“[A]lthough defendant's argument regarding patent prosecution history estoppel may well ultimately prove to be successful, the issue was premature and that it should properly follow claim construction and disclosure of plaintiff's specific infringement contentions.” (internal quotation marks omitted)).

In its reply brief, however, Camco argues “[t]he prosecution history is a public record and both the Fourth Circuit and the Federal Circuit have made clear that such documents may be considered on a 12(b)(6) motion,” relying on Ottah v. Fiat Chrysler, 884 F.3d 1135, 1141-42 (Fed. Cir. 2018) and Classen Immunotherapies, Inc. v. Shionogi, Inc., 993 F. Supp. 2d 569, 579-80 (D. Md. 2014). (Camco’s Reply (Doc. 16) at 3.)

The court finds these cases distinguishable from the present case. First, Ottah involved a patent entitled “Book Holder,” described as “a removable book holder assembly for use by a person in a protective or mobile structure such as a car

seat, wheelchair, walker, or stroller," which had "an adjustable, releasable clipping means and a support arm configured for . . . adjustment of the book supporting surface of the book holder to hold a book in a readable position in front of the user." Ottah, 884 F.3d at 1137. The patent holder sued several car makers for infringement, which were producing and selling back-up cameras mounted on vehicles. Id. at 1138, 1141. The district court granted the motion to dismiss the plaintiff's infringement claim, and the Federal Circuit affirmed. Id. at 1141-42. In doing so, the Federal Circuit concluded that "the record negates access to equivalency of cameras and books. The district court correctly found that the 'book holder' cannot plausibly be construed to include or be the equivalent of a camera holder, in view of the specification and the prosecution history." Id. at 1141-42.

The district court, however, only relied upon the patent itself in its analysis of the motion to dismiss. See Ottah v. BMW, 230 F. Supp. 3d 192, 196-97 (S.D.N.Y. 2017). It never cited to nor appeared to rely on the prosecution history. The court finds this persuasive.

Further, Classen Immunotherapies is also distinguishable. The issue there involved 35 U.S.C. § 154(d), which provides provisional patent rights for the time period "beginning on the



date of [the patent application's] publication" and "ending on the date the patent is issued." 993 F. Supp. 2d at 580 (citing 35 U.S.C. § 154(d)(1)). To be an actionable claim, (1) the alleged infringer must have had "actual notice of the published patent application" and (2) the "invention as claimed in the patent" must be "substantially identical to the invention as claimed in the published patent application." 35 U.S.C. § 154(d). The district court in Maryland was therefore required to examine the patent applications to determine whether the patents at issue were "substantially identical" to the applications. 993 F. Supp. 2d at 579-80. In contrast, the present case does not involve § 154(d) nor provisional patent rights; Classen Immunotherapies is therefore inapplicable.

This court will decline to analyze the prosecution history here and will deny Defendants' motions to dismiss Plaintiff's doctrine of equivalents claims.

#### **IV. CONCLUSION**

For the reasons set forth herein, the court will deny Defendants' motions to dismiss.

**IT IS THEREFORE ORDERED** that the motion to dismiss or transfer filed by Defendants Haier US Appliance Operation, LLC, and Haier US Appliance Solutions, Inc., (1:19CV675 (Doc. 7), and

the motion to dismiss filed by Camco Manufacturing, Inc.,  
(1:19CV280 (Doc. 8), are **DENIED**.

This the 11th day of March, 2020.

  
United States District Judge