

**UNITED STATES DISTRICT COURT  
SOUTHERN DISTRICT OF OHIO  
WESTERN DIVISION**

DENIS CIMAF, INC.,	:	Case No. 1:17-cv-820
	:	
Plaintiff,	:	Judge Timothy S. Black
	:	
vs.	:	
	:	
FECON, INC.,	:	
	:	
Defendant.	:	

**ORDER ON CLAIM CONSTRUCTION**

Plaintiff Denis Cimaf, Inc. (“Cimaf”) filed a complaint alleging that Defendant Fecon, Inc., (“Fecon”) has infringed and continues to infringe U.S. Patent No. 6,764,035, entitled “Brush Cutter” (the “’035 Patent”). (Doc. 1). Defendant Fecon filed a counterclaim seeking declaratory judgment that it has not infringed and it is not infringing on the ‘035 Patent. (Doc. 5)

This matter is now before the Court for construction of the ‘035 Patent pursuant to *Markman v. Westview Instruments, Inc.*, 52 F.3d 967 (Fed. Cir. 1995) (*en banc*), *aff’d*, 517 U.S. 370 (1996). The parties exchanged the claim terms that are in dispute and submitted to the Court a Joint Claim Construction and Prehearing Statement, pursuant to Local Patent Rule 105.2(d). (Doc. 27). The parties submitted briefs in support of their proposed claim constructions. (Docs. 28, 29, 32, 33). The Court held a *Markman* hearing on March 19, 2019 during which counsel for the parties presented arguments in support of their respective construction of claims at issue. (Doc. 35).

Relying on the parties' briefs, evidence, and oral arguments, the Court will construe each of the disputed terms.

## **I. THE PATENT AT ISSUE**

The '035 Patent, dated July 20, 2004 and naming Cimap as the assignee, discloses inventions related to brush cutters that attach to vehicles for mulching purposes. The abstract of the '035 Patent describes the claimed brush cutter invention as follows:

A brush cutting head having a cylindrical, tubular, support base. A plurality of cutting tooth mounting blocks are fixedly mounted on the cylindrical outer surface of the base, the blocks extending transverse to the longitudinal axis of the base, each block having a front face and sides. A cutting tooth is provided for each mounting block, each cutting tooth made from a plate having a uniform thickness with an inner surface and an outer surface. Each tooth has a straight, relatively long, base section and a straight, relatively short, cutting section bent from one end of the base section toward the inner surface to form an obtuse angle between the inner surface of the base section and the inner surface of the cutting section. Each tooth is mounted on the block with the base section of the tooth adjacent the front face of the block and the base section extending outwardly from the base, and with the cutting section above the block and extending forwardly from the base section of the tooth.

(Doc. 27-2 at 2).

The parties' current dispute concerns the construction of four terms in two of the '035 Patent's claims (Claims 20 and 21).

Claim 20 provides:

A brush cutting head having a cylindrical, tubular, base; a plurality of cutting tooth mounting blocks fixedly mounted on the outer cylindrical surface of the base; a cutting tooth detachably mounted on each block, each tooth having a cutting edge, the cutting edge located radially outwardly past the block; and a protective guard associated with each block, the guard mounted on the cylindrical

surface of the base in front of the block and extending forwardly from the block in a circumferential direction about a portion of the base; each guard projecting radially outwardly from the surface a distance at least equal to the height of the block but less than the height of the cutting edge from the surface, the guard preventing the block from being struck by an object while allowing the tooth to cut when the cutting head is rotated to cut brush.

(*Id.* at 12).

Claim 21 provides:

A cutting head as claimed in claim **20** wherein the protector is in the form of a narrow, broken, ring that extends substantially circumferentially about the surface of the base, transverse to the longitudinal axis of the base, the protector terminating a short distance in front of the block to provide a clearance space in front of the block, and the cutting tooth on the block, for the chips produced by the tooth.

(*Id.*).

The parties dispute the construction of the following four terms or phrases in Claims 20 and 21 of the '035 Patent: (1) "cutting tooth mounting blocks"; (2) "cutting tooth"; (3) "detachably mounted on each block"; and (4) "each guard projecting radially outwardly from the surface a distance at least equal to the height of the block but less than the height of the cutting edge from the surface." The Court will construe each disputed term/phrase in turn.

## II. STANDARD OF REVIEW

Claim construction is a matter of law to be decided exclusively by the Court. *Markman v. Westview Instruments, Inc.*, 52 F.3d 967, 970-71 (Fed. Cir. 1995) (*en banc*), *aff'd*, 517 U.S. 370. "[T]he claims of a patent define the invention to which the patentee

is entitled the right to exclude.” *Innova/Pure Water, Inc. v. Safari Water Filtration Sys., Inc.*, 381 F.3d 1111, 1115 (Fed. Cir. 2004).

Claim terms are “generally given their ordinary and customary meaning.” *Phillips v. AWH Corp.*, 415 F.3d 1303, 1312 (Fed. Cir. 2005). “The ordinary and customary meaning of a claim term is the meaning that the term would have to a person of ordinary skill in the art in question at the time of the invention, *i.e.*, as of the effective date of the patent application.” *Id.* at 1313. Absent an express intent to the contrary, a patentee is presumed to have intended the ordinary meaning of a claim term. *York Prods. v. Cent. Tractor Farm & Family Ctr.*, 99 F.3d 1568, 1572 (Fed. Cir. 1996). The Court must also consider the specification “to determine whether the inventor has used any terms in a manner inconsistent with their ordinary meaning.” *Id.* Finally, the Court may consider “the prosecution history of the patent, if in evidence.” *Vitronics Corp. v. Conceptronic, Inc.*, 90 F.3d 1576, 1582 (Fed. Cir. 1996). If these documents unambiguously define the scope of the patented invention, there is no need for the Court to consider any extrinsic evidence. *Id.* at 1583.

In construing claims, the Court determines whether or not a term requires construction. *U.S. Surgical Corp. v. Ethicon, Inc.*, 103 F.3d 1554, 1568 (Fed. Cir. 1997). The Court is not required to accept a construction of a term, even if the parties have stipulated to it, but instead may arrive at its own construction of claim terms, which may differ from the constructions proposed by the parties. *Pfizer, Inc. v. Teva Pharms., USA, Inc.*, 429 F.3d 1364, 1376 (Fed. Cir. 2005). “The appropriate starting point [...] is always

with the language of the asserted claim itself.” *Comark Commc’ns, Inv. v. Harris Corp.*, 156 F.3d 1182, 1186 (Fed. Cir. 1998). Generally, the terms of a patent should be construed consistently throughout the patent. *Phillips*, 415 F.3d at 1314; *Rexnord Corp. v. Laitram Corp.*, 274 F.3d 1336, 1342 (Fed. Cir. 2001) (“[A] claim term should be construed consistently with its appearance in other places in the same claim or in other claims of the same patent.”). “When the specification explains and defines a term used in the claims, without ambiguity or incompleteness, there is no need to search further for the meaning of the term.” *Multiform Desiccants, Inc. v. Medzam Ltd.*, 133 F.3d 1473, 1478 (Fed. Cir. 1998).

The general rule is that terms in the claim are to be given their ordinary and accustomed meaning. *Reinshaw v. Marposs Societa’ Per Azioni*, 158 F.3d 1243, 1249 (Fed. Cir. 1998). General descriptive terms will ordinarily be given their full meaning; modifiers will not be added to broad terms standing alone. *See, e.g., Virginia Panel Corp. v. MAC Panel Co.*, 133 F.3d 860, 865-66 (Fed. Cir. 1997). A court must presume that the terms in the claim mean what they say and, unless otherwise compelled, give full effect to the ordinary and accustomed meaning to skilled artisans of claim terms. *See, e.g., Nike Inc. v. Wolverine World Wide, Inc.*, 43 F.3d 644, 646 (Fed. Cir. 1994).

In order to overcome this heavy presumption in favor of the ordinary meaning of claim language, it is clear that “a party wishing to use statements in the written description to confine or otherwise affect a patent’s scope must, at the very least, point to a term or terms in the claim with which to draw in those statements.” *Renishaw*, 158

F.3d at 1248. That is, claim terms cannot be narrowed by reference to the written description or prosecution history unless the language of the claims invites reference to those sources. *See, e.g., McCarty v. Lehigh Valley R.R.*, 160 U.S. 110, 116 (1895) (“If we once begin to include elements not mentioned in the claim in order to limit such claim ..., we should never know where to stop”).

Courts have available to them a number of canons of construction which aid in construing patent claims. Among them are:

- 1) Each claim in a patent has a different scope. A dependent claim has a narrower scope than the claim upon which it depends.
- 2) Claims are not limited to the preferred embodiment disclosed in the specification.
- 3) Ordinarily, different words in a patent have different meanings.
- 4) Ordinarily, the same word in a patent has the same meaning.
- 5) Ordinarily, the meaning should align with the purpose of the patented invention.
- 6) Ordinarily, general descriptive terms are given their full meaning.
- 7) If possible, claims should be construed so as to preserve their validity.
- 8) Ordinarily, absent broadening language, numerical ranges are construed exactly as written.
- 9) Ordinarily, absent recitation of order, steps of a method are construed to have a particular order.
- 10) Absent highly persuasive evidentiary support, a construction should literally read on the preferred embodiment.

Patent Law and Practice, Fifth Edition, Herbert F. Schwartz at 134-136.

Courts may also consider the patent's prosecution history, if in evidence. The prosecution history limits the interpretation of claim terms so as to exclude any interpretation that was disclaimed during prosecution. *Southwall Techs., Inc. v. Cardinal IG Co.*, 54 F.3d 1570, 1576 (Fed. Cir. 1995). The prosecution history "constitutes a public record of the patentee's representations concerning the scope of and meaning of the claims, and competitors are entitled to rely on those representations when ascertaining the degree of lawful conduct." *Seachange Int'l, Inc. v. C-COR, Inc.*, 413 F.3d 1361, 1369 (Fed. Cir. 2005).

In most circumstances, analysis of the intrinsic evidence alone will resolve claim construction disputes. *See Vitronics*, 90 F.3d at 1583. Courts must first look to intrinsic evidence (*i.e.*, the claim itself, specifications, prosecution history and prior art cited in the patent) to resolve any ambiguities. *Id.* at 1582. Extrinsic evidence may be considered, as it "can shed light on the relevant art,' but is less significant than the intrinsic record in determining the 'legally operative meaning of disputed claim language.'" *C.R. Bard, Inc. v. U.S. Surgical Corp.*, 388 F.3d 858, 862 (Fed. Cir. 2004) (*quoting Vanderlande Indus. Nederland BV v. Int'l Trade Comm'n*, 366 F.3d 1311, 1318 (Fed. Cir. 2004)).

Dictionaries and technical treatises, which are extrinsic evidence, hold a "special place" and may sometimes be considered along with the intrinsic evidence when determining the ordinary meaning of claim terms. *Id.* at 1267. However, the Federal Circuit cautions against the use of nonscientific dictionaries, lest dictionary definitions be converted into

technical terms of art having legal, not linguistic, significance. *Id.*<sup>1</sup>

### III. THE COURT’S CONSTRUCTION OF THE CLAIMS

#### A. Term 1: “cutting tooth mounting blocks” (claim 20)

Disputed Term/Phrase	Plaintiff Cimaf's Proposed Construction	Defendant Fecon's Proposed Construction
“cutting tooth mounting blocks” (claim 20)	No construction necessary. This term should be given its plain and ordinary meaning.	Cutting tooth mounting blocks, each of which has a corner formed by a front surface and a bottom mounting surface.

Cimaf contends that no construction of the term “cutting tooth mounting blocks” is required and the term should be given its plain and ordinary meaning.

Fecon, on the other hand, contends that its proposed construction of “cutting tooth mount blocks” is necessary because Cimaf has purportedly disavowed a broader claim scope. Fecon seeks to add “each of which has a corner formed by a front surface and a bottom mounting surface” to the term “cutting tooth mounting blocks.” Fecon contends that Cimaf explicitly disavowed the broader claim scope of “cutting tooth mounting blocks” by using terms such as “the invention” or “the present invention” in the ‘035 Patent. *See Hill-Rom Servs., Inc. v. Stryker Corp.*, 755 F.3d 1367, 1372 (Fed. Cir. 2014) (“we have held that disclaimer applies when the patentee makes statements such as ‘the present invention requires . . .’ or ‘the present invention is.’”).

Fecon points to language in the ‘035 Patent that states “The step **31** [of the mounting block] has a top abutment surface **33** which forms, with the bottom of the front

---

<sup>1</sup> Here, neither party relies on extrinsic evidence and the Court finds that extrinsic evidence is unnecessary to construe the disputed terms/phrases.



surface **25**, an interior corner **35**. In accordance with the present invention, the front surface **25** is angled slightly forwardly from a radial line RL of the inner surface **23** which line passes through the interior corner **35**.” (Doc. 27-2 at 9). Because the ‘035 Patent uses the term “the present invention,” Fecon contends that Cimaf has disavowed a broader claim scope. This argument lacks merit.

There are only two exceptions to the general rule that claim terms are given their plain and ordinary meaning: “1) when a patentee sets out a definition and acts as his own lexicographer, or 2) when the patentee disavows the full scope of the claim term either in the specification or during prosecution.” *Thorner v. Sony Computer Entm't Am. LLC*, 669 F.3d 1362, 1365 (Fed. Cir. 2012).

A closer look at *Hill-Rom* demonstrates that disavowal may occur when a patentee makes statements such as “the present invention **requires**”, “the present invention **is**” or “**all embodiments** of the present invention are.” *Hill-Rom*, 755 F.3d at 1372 (emphasis added). However, the ‘035 Patent merely states “**in accordance** with the present invention.” (Doc. 27-2 at 9) (emphasis added). The *Hill-Rom* court specifically found that a patent including the language “in accordance with the present invention” did not disavow a broader scope of a claim. *Hill-Rom*, 755 F.3d at 1377 (“The fact that the specification indicates that in one embodiment, messages are sent to the wall interface unit “in accordance with the present invention,” does not mean that a wall interface unit must be present in all embodiments of the invention. . . . There is no lexicography or disavowal that would support importing this structural limitation from the specification

into the claims.”).

Here, the Court finds that Cimaf has not disavowed the full scope of the term “cutting tooth mounting blocks” by using the phrase “in accordance with the present invention.” (Doc. 27-2 at 8). As noted, claims are not limited to the preferred embodiment disclosed in the specification. Moreover, the Court agrees with Cimaf that Fecon’s proposed claim term construction attempts to “cherry pick particular words from particular examples in the specification and elevate them as meeting the standard of ‘clear disavowal’ of claim scope.” (Doc. 32 at 6). The ‘035 patent does not repeatedly and uniformly describe the “cutting tooth mounting blocks” with the additional language in Fecon’s proposed construction. *See ICU Med., Inc. v. Alaris Med. Sys., Inc.*, 558 F.3d 1368, 1374–75 (Fed. Cir. 2009) (finding that importing limitations from the specification into the claims may be proper where the specification “repeatedly and uniformly describes the spike as a pointed instrument for the purpose of piercing a seal inside the valve.”) Therefore, it is inappropriate to import Fecon’s proposed limitations into Claim 20 of the ‘035 Patent.

Accordingly, because the Cimaf has not disavowed the broader claim scope of the term “cutting tooth mounting blocks” and has not repeatedly and uniformly described “cutting tooth mounting blocks” in any other way, the Court finds that no construction is necessary.

**B. Term 2: “cutting tooth” (claims 20, 21)**

Disputed Term/Phrase	Plaintiff Cimag's Proposed Construction	Defendant Fecon's Proposed Construction
“cutting tooth” (Claims 20, 21)	No construction necessary. This term should be given its plain and ordinary meaning.	Cutting tooth that is made from a plate with a uniform thickness, where the tooth has a straight cutting section and the remainder of the tooth is a straight base section, such that the cutting section is bent toward the inner surface of the base section to form an obtuse angle, and where the entirety of the base section is fastened to the block.

Next, Cimag contends that no construction of the term “cutting tooth” is required and the term should be given its plain and ordinary meaning.

Fecon argues that the term “cutting tooth” must be construed to limit it only to the description consistent with the specification. Fecon contends that the cutting tooth is always described as “(1) being made from a plate with a uniform thickness, (2) having a straight cutting section, (3) having a remaining straight base section, (4) having a cutting section that is bent toward the inner surface of the base section to form an obtuse angle, and (5) having the entirety of the base section fastened to the block.” (Doc. 33 at 10). Therefore, Fecon proposes adding all of those additional descriptions to the term “cutting tooth” because a person of skill in the art “could only understand ‘cutting tooth’ to have the meaning proposed by Fecon.” (*Id.*).

While Fecon is correct that the specification must be considered in evaluating a disputed term during claim construction, Fecon’s proposed construction is contrary to the well-established rule that limitations from particular embodiments in the specification should not be imported into the claims themselves. *Phillips*, 415 F.3d at 1323. As the Federal Circuit has explained, it is “not enough that the only embodiments, or all of the embodiments, contain a particular limitation to limit a claim term beyond its ordinary meaning.” *Aventis Pharma S.A. v. Hospira, Inc.*, 675 F.3d 1324, 1330 (Fed. Cir. 2012). “[E]ven if a specification has only one embodiment, its claims will not be confined to that example ‘unless the patentee has demonstrated a clear intention to limit the claim scope using words or expression of manifest exclusion or restriction.’” *Aria Diagnostics, Inc. v. Sequenom, Inc.*, 726 F.3d 1296, 1301 (Fed. Cir. 2013) (quoting *Liebel–Flarsheim Co. v. Medrad, Inc.*, 358 F.3d 898, 906 (Fed. Cir. 2004)).

The Federal Circuit provided the following guidance to determine whether a patentee has demonstrated a clear intention to limit the claim scope:

To avoid importing limitations from the specification into the claims, it is important to keep in mind that the purposes of the specification are to teach and enable those of skill in the art to make and use the invention and to provide a best mode for doing so. *See Spectra–Physics, Inc. v. Coherent, Inc.*, 827 F.2d 1524, 1533 (Fed. Cir. 1987). One of the best ways to teach a person of ordinary skill in the art how to make and use the invention is to provide an example of how to practice the invention in a particular case. Much of the time, upon reading the specification in that context, it will become clear whether the patentee is setting out specific examples of the invention to accomplish those goals, or whether the patentee instead intends for the claims and the embodiments in the specification to be strictly coextensive. *See [SciMed Life Sys., Inc. v. Advanced Cardiovascular Sys., Inc.]*, 242 F.3d, 1337, 1341 (Fed. Cir.

2001)]. The manner in which the patentee uses a term within the specification and claims usually will make the distinction apparent. *See Snow v. Lake Shore & M.S. Ry. Co.*, 121 U.S. 617, 630, 7 S.Ct. 1343, 30 L.Ed. 1004[ ] (1887) (it was clear from the specification that there was “nothing in the context to indicate that the patentee contemplated any alternative” embodiment to the one presented).

In the end, there will still remain some cases in which it will be hard to determine whether a person of skill in the art would understand the embodiments to define the outer limits of the claim term or merely to be exemplary in nature. While that task may present difficulties in some cases, we nonetheless believe that attempting to resolve that problem in the context of the particular patent is likely to capture the scope of the actual invention more accurately than either strictly limiting the scope of the claims to the embodiments disclosed in the specification or divorcing the claim language from the specification.

*Phillips*, 415 F.3d at 1323–24.

As discussed *supra*, Cimaf’s use of the phrase “in accordance with the present invention” does not explicitly disavow the broader scope of the term “cutting tooth” in Claims 20 and 21. As with the term “cutting tooth mounting blocks,” Fecon again picks and chooses from different descriptions of “cutting tooth” found in the specification to attempt to limit the scope of “cutting tooth” in Claims 20 and 21. However, the additional 60 words that Fecon states are necessary to properly construe “cutting tooth” are not repeatedly and uniformly used to describe “cutting tooth” throughout the specification. Therefore, upon the review of the ‘035 Patent’s specifications, the Court finds that Cimaf did not expressly intend for the term “cutting tooth” in Claims 20 and 21 to be limited by the descriptions in the specification.

Accordingly, because the Cimaf has not disavowed the broader claim scope of the term “cutting tooth”, and has not repeatedly and uniformly described “cutting tooth” in any other way, the Court finds that no construction is necessary.

**C. Term 3: “detachably mounted on each block” (claim 20)**

Disputed Term/Phrase	Plaintiff Cimaf's Proposed Construction	Defendant Fecon's Proposed Construction
“detachably mounted on each block” (Claim 20)	No construction necessary. This term should be given its plain and ordinary meaning.	Detachably mounted on each block such that the base section of the tooth is flush with the block's front surface and fits snugly into the block's corner.

Again, Cimaf contends that no construction of the term “detachably mounted on each block” is required and the term should be given its plain and ordinary meaning.

Fecon argues that the term “detachably mounted on each block” must be limited with respect to how a tooth mounts onto a “mounting block.” Fecon contends that the term must be construed to clarify that the tooth “(1) mounts ‘flush’ with the block’s front surface and (2) fits snugly into the block’s corner.” (Doc. 33 at 11). Fecon states that “Fecon’s proposed construction *are present in every description of the invention.*” (*Id.* at 12 (emphasis in original)). However, as Cimaf notes “Fecon relies on the ‘035 Patent at column 2, lines 2-5, but this passage does not define ‘detachably mounted on each block’ as meaning or requiring the tooth to fit ‘flush’ or ‘snugly’ with the block. In fact, those words do not appear at all in that passage.” (Doc. 32 at 8). The Court agrees with Cimaf.

For the same reasons as stated *supra*, the Court again finds that Fecon has failed to show that Cimaf expressly intended to disavow the broader scope of the term “detachably mounted on each block.” Upon review of the ‘035 Patent, Fecon’s argument that the patent repeatedly and uniformly describes the tooth as mounting “flush” or fitting “snugly” is without merit. The Court finds that it is inappropriate to insert additional limitations on the term “detachably mounted on each block.” Accordingly, no construction on this term is necessary and “detachably mounted on each block” is to be given its plain and ordinary meaning.

**D. Term 4: “each guard projecting radially outwardly from the surface at a distance at least equal to the height of the block but less than the height of the cutting edge from the surface” (claim 20)**

Disputed Term/Phrase	Plaintiff Cimaf's Proposed Construction	Defendant Fecon's Proposed Construction
<p>“each guard projecting radially outwardly from the surface a distance at least equal to the height of the block but less than the height of the cutting edge from the surface”  (claim 20)</p>	<p>No construction necessary other than the following phrases:  1) “each guard projecting radially from the surface a distance,” which is measured at location “H”: the distance measured radially from the base to the outer surface of the guard along the axis that is perpendicular to the axis along which “h” is measured; and  2) “height of the block,” which is measured at location “h”: the distance measured radially from the base to the outer surface of the block behind the mounting bolt.</p>	<p>Each guard projecting radially outwardly from the surface a distance at least equal to the greatest distance that the block projects radially outwardly from the surface but less than the least distance that the cutting edge projects radially outwardly from the surface.</p>

The last disputed claim phrase relates to the protective guard (or “protective collar”) that protects the mounting block, and how to measure the height of the protective guard and the height of the block. For this phrase, both parties assert that claim construction is necessary.

Cimaf contends that that the term “height” in Claim 20 requires construction and refers to Figure 2 and the specification of the ‘035 Patent to support its proposed construction. The below shows Figure 2 from the Patent.

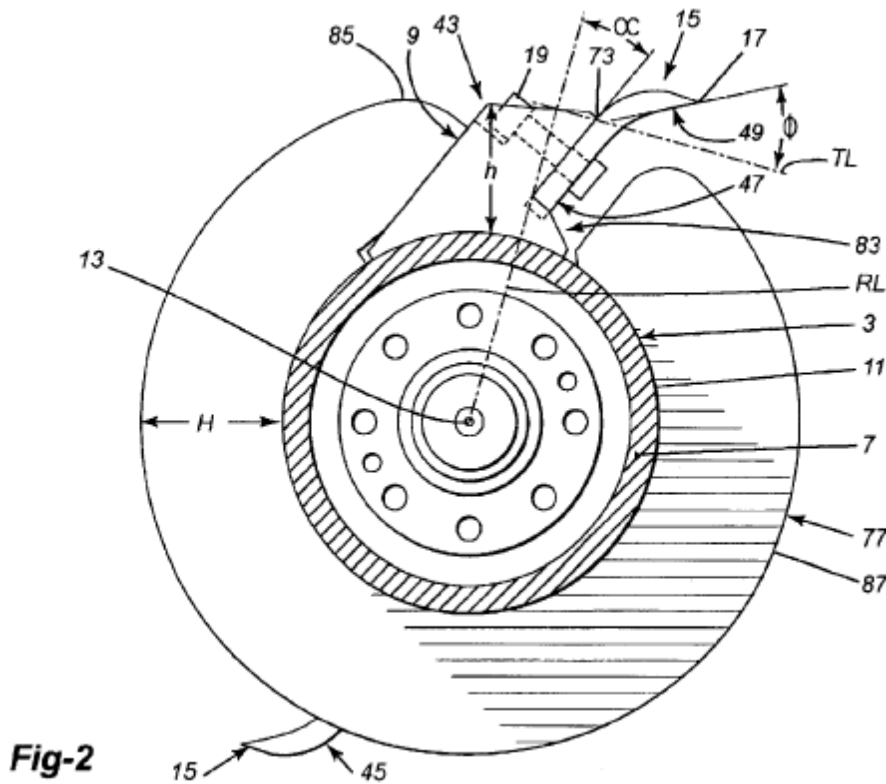

(Doc. 27-2 at 3). In this figure, “H” refers to the height of the protective guard/collar and “h” refers to the height of the block. The specification goes on to describe the height of “H” and “h”: “Each collar 77 has a height ‘H’ equal to, or slightly greater than, the height ‘h’ of the block.” (*Id.* at 5:56–57). Therefore, Cimaf emphasizes that the inventor has



specifically defined the guard/collar height to be measured at “H” on Figure 2, and the height of the block should be measured at “h” on Figure 2. Cimaf notes that these height definitions are clear and definitive and not couched with terms such as “for example” or “may have” (Doc. 28 at 17), and, therefore, Figure 2 is not a preferred embodiment. Cimaf argues that the inventor thus has been his own “lexicographer” and defined the guard/collar height (“H”) and block height (“h”) in the specification. *See Markman*, 52 F.3d at 980 (“a patentee is free to be his own lexicographer”).

Fecon argues that Cimaf’s proposed construction is improper because Figure 2 only shows a preferred embodiment, which is insufficient to support a conclusion that Cimaf acted as its own lexicographer. When a patentee merely describes a figure showing a preferred embodiment, the patentee is not acting as his/her own lexicographer. *See Laryngeal Mask Co. Ltd. V. Ambu*, 618 F.3d 1367, 1372 (Fed. Cir. 2010). Fecon also argues that Cimaf’s proposed construction is inappropriate because it ignores the stated purpose of the invention and renders the patent invalid as indefinite.

On the other hand, Fecon contends that its proposed construction is consistent with the phrase’s plain and ordinary meaning. Fecon argues that the claim language should be construed in light of a patent’s stated purpose and benefits. *See Renishaw PLC v. Marposs Societa' per Azioni*, 158 F.3d 1243, 1250 (Fed. Cir. 1998) (reasoning that a claim interpretation that aligns with the purpose of the invention is likely to be correct). Fecon asserts that the stated purpose and benefit of the protective guard is “to keep the mounting blocks from being directly struck by rocks or trees while allowing cutting teeth

to extend past the guard and cut.” (Docs. 33 at 13; 27-2 at 2:14–16, 5:65–6:2). Fecon contends that its proposed construction aligns with this stated purpose.

Yet Cimaf argues that Fecon’s proposed construction ignores the fact that the guard/collar and block have different heights at different locations and that Cimaf’s proposed construction clarifies where height should be measured. (Doc. 28 at 18). For example, looking near point 9 on Figure 2, the collar tapers down to make it closer to the block. Additionally, at point 73, the block is clearly higher than at is at position “h.” Finally, Cimaf criticizes Fecon’s proposed construction language because Fecon’s additional proposed language appears nowhere in the claim language, the specification, or the prosecution history.

A court may depart from a term or phrase’s plain meaning if a patentee has acted as a lexicographer. *Phillips*, 415 F.3d at 1316. When a patentee acts as a lexicographer, the specification is particularly relevant because “the specification may reveal a special definition given to a claim term by the patentee that differs from the meaning it would otherwise possess.” *Id.* at 1316 (citing *CCS Fitness, Inc. v. Brunswick Corp.*, 288 F.3d 1359, 1366 (Fed. Cir. 2002)).

Here, the Court finds that, upon considering the specification (Doc. 27-2 at 5:57–58) and Figure 2, the ‘035 Patent inventor was acting as his own lexicographer by expressly defining the height of the guard/collar “H” and the height of the block “h.” *See Int’l Rectifier Corp. v. IXYS Corp.*, 361 F.3d 1363, 1373 (Fed. Cir. 2004) (finding that an inventor had acted as his own lexicographer based on figures and accompanying text in

the specification). Figure 2 is not merely a preferred embodiment as the specification clearly and definitely defines the height of the guard/collar “H” and the height of the block “h” and there is no language that suggests that these elements of the invention are preferred embodiments or examples. Because the specification clarifies the scope of the phrase “each guard projecting radially outwardly from the surface a distance at least equal to the height of the block but less than the height of the cutting edge from the surface” by defining the height of the guard and the height of the block, the Court finds that Cimaf’s proposed construction is consistent with the plain and ordinary meaning of the claim language and should be adopted. Moreover, the Court does not find that Cimaf’s proposed construction is at odds with the stated purpose of the invention.

Accordingly, the term “each guard projecting radially outwardly from the surface a distance” is construed as being measured at location “H”: the distance measured radially from the base to the outer surface of the guard along the axis that is perpendicular to the axis along which “h” is measured. Additionally, the term “height of the block” is to be construed as being measured at location “h”: the distance measured radially from the base to the outer surface of the block behind the mounting bolt.

#### IV. CONCLUSION

Therefore, the parties shall construe the contested terminology of the ‘035 Patent as set forth in this Order. **IT IS SO ORDERED.**

Date: 4/22/19

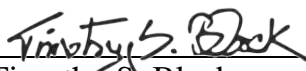
  
\_\_\_\_\_  
Timothy S. Black  
United States District Judge