

**UNITED STATES DISTRICT COURT
SOUTHERN DISTRICT OF OHIO
WESTERN DIVISION**

SUMMIT INDUSTRIAL SUPPLY, LLC,	:	Case No. 1:20-cv-385
	:	
Plaintiff,	:	Judge Timothy S. Black
	:	
vs.	:	
	:	
TRIPLE CROWN CONSULTING, LLC,	:	
	:	
Defendant.	:	

**ORDER GRANTING IN PART AND DENYING IN PART
PLAINTIFF’S MOTION FOR DEFAULT JUDGMENT (Doc. 8)**

This civil action is before the Court on Plaintiff Summit Industrial Supply, LLC’s motion for default judgment. (Doc. 8). Defendant Triple Crown Consulting, LLC (“TCC”) did not respond.

I. BACKGROUND

A. Procedural Background

Summit filed a complaint on May 14, 2020. (Doc. 1). TCC’s registered agent was personally served with the summons and complaint on May 15, 2020. (Doc. 5). Pursuant to Fed. R. Civ. P. 12(a), TCC was required to file a responsive pleading by June 5, 2020. To date, TCC has not filed any responsive pleading or otherwise engaged in the action. On July 24, 2020, the Clerk issued an entry of default against TCC. (Doc. 7). Summit subsequently filed the instant motion for default judgment, seeking damages, a permanent injunction, attorney fees and costs, and pre- and post-judgment interest. (Doc. 8).

B. Factual Background

Summit is the assignee of U.S. Patent No. 10,029,188 (INTEGRATED DISTILLATION CHAMBER AND DISCHARGE UNIT WITH INTEGRATED KEY) (the “’188 patent”), which patent was issued to Elliot Kremerman on July 24, 2018. (Doc. 1 at ¶ 8; Doc. 1-1). The claims of the ’188 patent cover an enhanced device for distillation. The distillation device facilitates heating of a solid or liquid to remove and collect gaseous vapors and allows distillation of small amounts of starting raw material and items which have close boiling points. (Doc. 1 at ¶ 9). An illustration of the device is as follows:

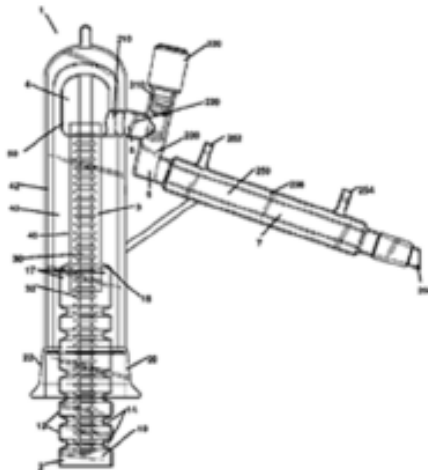

(*Id.* at ¶ 10).

At the direction of TCC, an infringing short path distillation head was imported, manufactured, and offered for sale during the MJBizCon trade sale in Las Vegas, Nevada from December 11-13, 2019. (*Id.* at ¶ 12). The device sold by TCC at the trade show was photographed:



Summit also later discovered that TCC sold a distillation system for \$32,000, using the infringing short path distillation head, to a hemp distiller in Covington Kentucky in May 2019. (Doc. 1 at ¶ 11). TCC knows of the existence of Summit's '188 patent and continues to infringe upon the patent by making, using, selling, and offering for sale infringing short path distillation heads. (*Id.* at ¶¶ 15– 18). TCC's short path distillation head literally uses, or under the doctrine of equivalents uses, the same elements as Summit's '188 patent, including Summit's: (1) distillation unit, (2) distillation key attached to the top side of said distillation unit; (3) a fraction collector through which said distillation key extends through from end to end entirely; (4) a middle distillation tube narrower than said fraction collector through which said distillation key extends through from end to end entirely; and (5) a lower distillation tube wider than said middle distillation tube through which said distillation key extends at least partially there-through. (*Id.* at ¶ 14).

On December 20, 2019, Summit sent a cease and desist letter to Across International, LLC, believing Across to be the infringer. (Doc. 8-13). Across

International responded on January 8, 2020, informing Summit that Across International was merely a distributor, and the device was supplied by TCC. (Doc. 8-14). However, in the interim, on December 31, 2019, Summit received a letter from TCC's counsel, acknowledging Summit's accusations of infringement. (Doc. 8-15).

After Summit filed the instant action, Summit's counsel and an individual associated with TCC, Jonathan Belton, communicated via email about resolving the litigation early. (Doc. 8-16). However, after Summit requested information from TCC about its distillation head sales and a formal commitment to cease infringing activity, Mr. Belton stopped responding. (*Id.*)¹

II. STANDARD OF REVIEW

Applications for default judgment are governed by Fed. R. Civ. P. 55(b)(2). "Following the clerk's entry of default pursuant to Fed. R. Civ. P. 55(a) and the party's application for default under Rule 55(b), the complaint's factual allegations regarding liability are taken as true, while allegations regarding the amount of damages must be proven." *Wood v. Bronzie*, No. 1:20-CV-231, 2020 WL 4015247, at *1 (S.D. Ohio July 16, 2020) (quotation and citations omitted). While liability may be shown by well-pleaded allegations, this Court is required to "conduct an inquiry in order to ascertain the

¹ Summit indicates that Summit's counsel and TCC's counsel originally engaged in communications prior to filing the lawsuit. After Summit filed the lawsuit, Summit communicated only with Mr. Belton. There is no explanation of whether TCC's original counsel was sent the complaint or when TCC stopped being represented (if ever); however, Summit's counsel confirmed in an email to Mr. Belton that counsel should speak with Mr. Belton, not his attorney.

amount of damages with reasonable certainty.” *Osbeck v. Golfside Auto Sales, Inc.*, No. 07-14004, 2010 WL 2572713, at *4 (E.D. Mich. June. 23, 2010).

“Ordinarily, the District Court must hold ‘an evidentiary proceeding in which the defendant has the opportunity to contest the amount [of damages].’” *Antoine v. Atlas Turner, Inc.*, 66 F.3d 105, 110 (6th Cir. 1995) (quoting *Greyhound Exhibitgroup, Inc. v. E.L.U.L. Realty Corp.*, 973 F.2d 155, 158 (2d Cir. 1992)). However, “Rule 55 does not require an evidentiary hearing as a prerequisite to the entry of default judgment if damages are contained in documentary evidence or detailed affidavits and can be ascertained by computation on the record before the Court.” *Caterpillar Fin. Servs. Corp. v. C & D Disposal Techs.*, No. 2:12-CV-00077, 2012 WL 12883333, at *1 (S.D. Ohio July 10, 2012).

III. ANALYSIS

TCC’s failure to respond to the complaint, application for entry of default, or motion for default judgment has made it clear that TCC has no intention of defending this action. The factual allegations in the complaint, except those related to damages, are deemed true. *Antoine*, 66 F.3d at 110. Thus, upon review of the record, the Court finds that default judgment is warranted in this case. And, with liability established, the Court must determine the extent of damages.

A. Injunctive Relief

First, Summit requests that TCC be permanently enjoined from future sale of the infringing short path distillation head or otherwise infringing upon the ’188 Patent. In determining whether to grant a permanent injunction, the Court considers the following

four-factor test: (1) whether the plaintiff suffered an irreparable harm; (2) whether the remedies available at law are inadequate; (3) whether the balance of hardships favors granting an injunction; and (4) whether the public interest would be served in granting an injunction. *Wynn Oil Co. v. Am. Way Service Corp.*, 943 F.2d 595, 608 (6th Cir. 1991).

1. Irreparable injury

Courts routinely find irreparable harm when the infringer and patent holder are direct competitors. *Bendix Comer. Vehicle, Sys., LLC v. Haldex Brake Prod. Corp.*, No. 1:09cv176, 2011 WL 14367 (N.D. Ohio Jan. 3, 2011). Here, Summit and TCC are direct competitors. Summit offers for sale, and sells, short path distillation heads, in direct competition with TCC's sales of the same, illegally obtained, short path distillation head. TCC also uses the infringing distillation head when selling distillation systems, competing with Summit's sale of distillation systems. Also, TCC uses Summit's short path distillation head, without license or permission from Summit. These facts show that Summit will likely suffer irreparable harm if TCC is not legally enjoined from infringing upon the '188 Patent.

2. Remedies available at law

By defaulting, TCC admits that it infringed upon Summit's patent. An "essential attribute of a patent grant is that it provides a right to exclude competitors from infringing the patent." *Acumed LLC v. Stryker Corp.*, 551 F.3d 1323, 1328 (Fed. Cir. 2008) (citing 35 U.S.C. § 154(a)(1) (2000)). Monetary damages would be insufficient to compensate for Summit's injury because monetary damages may not prevent TCC (or another competitor) from infringing upon the patent, knowing they would only need to pay

Summit money for infringement. Thus, there are no assurances, absent a permanent injunction, that TCC will not continue to sell infringing products again in the future.

3. Balance of hardships

An injunction will not unfairly harm TCC; the injunction prohibits TCC from continuing to infringe upon Summit's patent. "One who elects to build a business on a product found to infringe cannot be heard to complain if an injunction against continuing infringement destroys the business so elected." *Broadcom Corp. v. Qualcomm Inc.*, 543 F.3d 683, 704 (Fed. Cir. 2008). The balance of hardships favors Summit.

4. Public interest

Finally, the public has a strong interest in maintaining the integrity of patents by enjoining patent infringement. *See, e.g., Smith & Nephew, Inc. v. Synthes (U.S.A.)*, 466 F. Supp. 2d 978, 985 (W.D. Tenn. 2006).

Thus, the four-factor test weighs heavily in favor of a permanent injunction. Summit's request for injunctive relief is **GRANTED**. TCC is enjoined and restrained from further infringement of the '188 Patent.

B. Lost Profit Damages

Next, Summit seeks monetary damages under a lost profit theory.

Damages for patent infringement must be "adequate to compensate for the infringement, but in no event less than a reasonable royalty for the use made of the invention by the infringer." 35 U.S.C. § 284. To establish entitlement to lost profits, "the patent owner has an initial burden to show a reasonable probability that he would have made the asserted sales 'but for' the infringement." *Grain Processing Corp. v. American*

Maize-Prods., 185 F.3d 1341, 1349 (Fed. Cir. 1999). To meet this burden, a patent owner generally must prove four factors: (1) demand for the patented products; (2) absence of acceptable non-infringing alternatives; (3) manufacturing and marketing capability to exploit the demand; and (4) the amount of the profit it would have made. *Panduit Corp. v. Stahl Bros. Fibre Works*, 575 F.2d 1152, 1156 (6th Cir. 1978).

Summit seeks \$22,315.12 in lost profits. Summit is entitled to these lost profit damages, having demonstrated the four *Panduit* factors. Specifically, Summit has demonstrated that: a distiller in Covington, Kentucky bought a distillation system from TCC which included the infringing patent; there is no acceptable non-infringing substitute for the short path distillation head which is included in the distillation system; Summit would have sold the distillation system to the Covington buyer but for TCC's infringement; and Summit would have profited \$22,315.12 for the sale of distillation system. (Doc. 8-1).

Accordingly, Summit's request for lost profit damages is **GRANTED**. Summit is awarded \$22,315.12 in damages.

C. Treble Damages

Summit also requests that the Court treble these damages. When damages are assessed for patent infringement, "the court may increase the damages up to three times the amount found or assessed." 35 U.S.C. § 284. "Section 284 gives district courts the discretion to award enhanced damages against those guilty of patent infringement." *Halo Elecs., Inc. v. Pulse Elecs., Inc.*, 136 S. Ct. 1923, 1935 (2016) (internal quotation and citation omitted). "Awards of enhanced damages under the Patent Act...are not to be

meted out in a typical infringement case, but are instead designed as a ‘punitive’ or ‘vindictive’ sanction for egregious infringement behavior. The sort of conduct warranting enhanced damages has been variously described in our cases as willful, wanton, malicious, bad-faith, deliberate, consciously wrongful, flagrant, or—indeed—characteristic of a pirate.” *Id.* at 1932. The Federal Circuit has clarified that “it is the circumstances that transform simple ‘intentional or knowing’ infringement into egregious, sanctionable behavior, and that makes all the difference.” *SRI Int’l, Inc. v. Cisco Sys., Inc.*, 930 F.3d 1295, 1308 (Fed. Cir. 2019).

The Court, in its discretion, declines to award enhanced damages.

Here, Summit alleges, which the Court considers as true, that TCC’s infringement was willful. (Doc. 1 at ¶ 18). Summit then argues that TCC’s failure to adequately respond to its cease and desist letter with evidence of non-infringement supports its request for enhanced, treble damages. (Doc. 8 at 16).² Summit points to no other allegations or evidence of egregious behavior to support enhanced damages.

Post-*Halo*, courts considering default judgment in patent infringement cases have declined to award enhanced damages when there were no allegations suggesting egregious conduct – conduct beyond that of a typical patent infringement case. *E.g. Levitation Arts, Inc. v. Plox, Inc.*, No. CV 17-1476-MN, 2020 WL 2730905, at *4 (D. Del. May 26, 2020), *report and recommendation adopted*, No. CV 17-1476 (MN), 2020

² Summit argues that enhanced damages are warranted based on a showing of objective recklessness, presumably apply the *Seagate* test for enhanced damages. (Doc. 8 at 16 (citing *In re Seagate Technology, LLC*, 497 F.3d 1360, 1371 (Fed. Cir. 2007))). The Supreme Court rejected the *Seagate* test, including the necessity of finding objective recklessness. *Halo Elecs.*, 36 S. Ct. at 1932–34.

WL 3103894 (D. Del. June 11, 2020); *LF Centennial Ltd. v. Inovex Furnishings Corp.*, No. 17-5824, 2019 WL 6655258, at *7 (C.D. Cal. Oct. 2, 2019); *Arnold v. Scales*, No. 15-45, 2016 WL 6155173, at *1 (M.D. Ga. Feb. 5, 2016). *Cf. Agio Int'l Co., Ltd. v. Zhejiang Longda Force Co.*, No. 1:15-CV-00192-MR, 2019 WL 1302634, at *5 (W.D.N.C. Mar. 21, 2019) (awarding enhanced damages when defendant acted in direct and knowing contravention of an injunctive order, indicating egregious behavior).

Accordingly, Summit's request for enhanced, treble damages is **DENIED**.

D. Attorney's Fees and Costs

Summit also requests \$54,035.25 in attorney fees and costs. (Doc. 8 at 16). Summit asks that the Court find that this case is "exceptional" and award costs and attorney's fees pursuant to 35 U.S.C. § 285. "[A]n 'exceptional' case is simply one that stands out from others with respect to the substantive strength of a party's litigating position (considering both the governing law and the facts of the case) or the unreasonable manner in which the case was litigated." *Octane Fitness, LLC v. ICON Health & Fitness, Inc.*, 572 U.S. 545, 554 (2014). "District courts may determine whether a case is 'exceptional' in the case-by-case exercise of their discretion, considering the totality of the circumstances." *Id.*³

The Court finds this an exceptional case given TCC's non-responsiveness and complete failure to address Summit's claims of infringement. Thus, the Court must determine reasonable attorney fees.

³ A case may be exceptional for purposes of attorney fees but not egregious for purposes of enhanced, treble damages.

District courts use the lodestar method to determine an award of reasonable attorneys' fees. The lodestar amount is "calculated by multiplying the number of hours reasonably expended on the litigation by a reasonable hourly rate." *Imwalle v. Reliance Medical Products, Inc.*, 515 F. 531, 551 (6th Cir. 2008).

1. Reasonable Hourly Rate

"A district court has broad discretion to determine what constitutes a reasonable hourly rate for an attorney." *Wayne v. Village of Sebring*, 36 F.3d 517, 531–32 (6th Cir. 1994), *cert. denied*, 514 U.S. 1127 (1995). "A reasonable fee is one that is 'adequately compensatory to attract competent counsel yet which avoids producing a windfall for lawyers.'" *Dowling v. Litton Loan Servicing LP*, 320 F. App'x 442, 446 (6th Cir. 2009) (citing *Geier v. Sundquist*, 372 F.3d 784, 791 (6th Cir. 2004)). To determine a reasonable hourly rate, a useful guideline is the prevailing market rate in the relevant community, defined as "that rate which lawyers of comparable skill and experience can reasonably expect to command." *Id.* at 447 (citing *Adcock-Ladd v. Sec'y of Treasury*, 227 F.3d 343, 350 (6th Cir. 2000)). The Court may also consider an attorney's own normal billing rates to help calculate a reasonable fee. *Hadix v. Johnson*, 65 F.3d 532, 536 (6th Cir. 1995).

Summit has submitted the Affidavit of Kevin Regan, attorney for Summit, in support of its request for attorneys' fees. (Doc. 8-9). Summit seeks \$545.00 per hour for work done by Mark Walters, an attorney with Lowe Graham Jones with over 20 years of intellectual property law and litigation experience. (*Id.* at ¶ 16). Summit also seeks \$375.00 per hour for the work of Kevin Regan, also an attorney with Lowe Graham Jones and with over 15 years of intellectual property law and litigation experience. (*Id.*)

Summit last seeks \$165.00 per hour for the work of Rischel Voigt, a paralegal with the firm with approximately 15 years of legal experience. (*Id.*) Considering the experience of the attorneys and paralegal in this case, the attorneys' normal billing rates, and the importance of attracting competent counsel to handle patent infringement matters, the Court finds that the requested hourly rates are reasonable.

2. Reasonable Number of Hours

In determining whether the number of hours expended on a case is reasonable, “the standard is whether a reasonable attorney would have believed the work to be reasonably expended in pursuit of success at the point in time when the work was performed.” *Wooldridge v. Marlene Industries Corp.*, 898 F.2d 1169, 1177 (6th Cir. 1990). “The documentation offered in support of the hours charged must be of sufficient detail to enable a court to determine with a high degree of certainty that such hours were actually and reasonably expended in the prosecution of such litigation.” *Bench Billboard Co. v. City of Toledo*, 759 F. Supp. 2d 905, 913 (N.D. Ohio 2010), *aff'd* in part, *rev'd* in part, 499 F. App'x 538 (6th Cir. 2012) (citing *United Slate Tile and Composition Roofers v. G & M Roofing and Sheet Metal Co., Inc.*, 732 F.2d 495, 502, n. 2 (6th Cir. 1984)). Additionally, counsel is expected to exercise billing judgment by excluding “hours that were not ‘reasonably expended.’” *Hensley v. Eckerhart*, 461 U.S. 424, 434 (1983).

Summit provides the Regan Affidavit to support the number of reasonable hours expended. According to Regan, Walters expended 51.2 hours, Voigt expended 12.9 hours, and Regan expended 58.1 hours on the litigation. (Doc. 8-9 at ¶ 18). Regan asserts these hours “were necessary and reasonable to investigate the infringement,

consult with the client, file the case, and seek default judgment against Summit.” (*Id.* at ¶ 19). Regan also generally states that Summit has incurred \$2,215.25 in costs. (*Id.*) This is all Summit provides.

The Court finds that Summit’s counsel has failed to submit sufficient documentation or detail to allow this Court to determine with a high degree of certainty that the claimed hours worked were actually and reasonably expended in the prosecution of this litigation. Counsel provides no billing records or time sheets justifying the number of hours billed by both counsel and counsel’s paralegal.⁴ Counsel also provides no explanation of the costs incurred.

Accordingly, Summit’s request for attorney fees and costs is **DENIED WITHOUT PREJUDICE**. Summit may renew its motion for attorney fees and costs with appropriate documentation within 14 days of this Order.

E. Pre- and Post- Judgment Interest

Summit last seeks an award of pre-judgment and post-judgment interest. *See* 28 U.S.C. 1961(a). Here, Summit discovered TCC’s infringement of the ’188 Patent at the trade show in Las Vegas in December 2019. TCC then immediately sought to protect its rights by issuing a cease and desist letter, and then by filing suit. Summit then discovered that TCC’s representative, Jonathan Belton, sold a distillation system to a company in Covington, Kentucky during May 2019; however, Summit is unable to provide an exact

⁴ Counsel vaguely asserts that the two, highly experienced intellectual property attorneys expended nearly 110 hours on this action. While such experienced counsel may have expended 110 hours on investigating the infringement, filing the complaint, and preparing the motion for default judgment, the Court requires more than such vague assertions to determine whether the 110 hours were actually and reasonably expended on this action.

date of purchase. Accordingly, an award of pre-judgment interest from the date of the cease and desist letter, December 20, 2019, through the date of judgment, is appropriate in this case. *See Gillette Co. v. Save & Disc. LLC*, No. 1:15-CV-636, 2016 WL 3745764, at *4 (S.D. Ohio July 13, 2016) (awarding pre-judgment interest from date of cease and desist letter).

Additionally, an award of post-judgment interest is also appropriate pursuant to 28 U.S.C. §1961(a), since TCC defaulted and Summit is likely to seek to attach assets or take other steps to secure payment of the judgment, which will likely delay the payment. In calculating pre-judgment and post-judgment interest, the rate of the 52-week Treasury Bill is an appropriate rate pursuant 28 U.S.C. § 1961. *See also Isaac Ford v. Uniroyal Pension Plan*, 154 F.3d 613, 619 (6th Cir. 1998). As of July 16, 2021, this rate was 0.08%.⁵ Compounded annually, this yields \$0.05 in interest per day.⁶ Accordingly, Plaintiff is entitled to pre-judgment interest from December 20, 2019 through the date the judgment is entered at a rate of \$0.05 per day, and post-judgment interest at the same daily rate from the date of judgment until the judgment is paid.⁷

⁵ See <http://www.treasury.gov/resource-center/data-chart-center/interest-rates/Pages/TextView.aspx?data=billrates>, accessed on July 16, 2021.

⁶ $0.0008/365 \times \$22,315.12 = \00.05

⁷ Since an award of pre-judgment interest is not punitive, it can only be assessed against actual damages. *Saint- Gobain Autover USA, Inc. v. Glass N. Am., Inc.*, No. 1:06cv2781, 2010 U.S. Dist. LEXIS 30906, at *75 (N.D. Ohio Mar. 31, 2010).

IV. CONCLUSION

For these reasons, Summit's motion for default judgment (Doc. 8) is **GRANTED IN PART and DENIED IN PART**. Judgment shall be entered in favor of the Summit and against Defendant Triple Crown Consulting, LLC as follows:

1. Summit's request for a permanent injunction is **GRANTED**. Triple Crown Consulting, LLC is hereby **ENJOINED** and **RESTRAINED** from infringing, in any manner, upon Summit's assigned patent, U.S. Patent No. 10,029,188.
2. Summit's request for monetary damages is **GRANTED**. Triple Crown Consulting, LLC **SHALL** pay damages in the amount of \$22,315.12 based on Summit's lost profits.
3. Summit's request for enhanced, treble damages is **DENIED**.
4. Summit's request for pre- and post-judgment interest is **GRANTED**. Triple Crown Consulting, LLC **SHALL** pay interest on the statutory award at in amount of \$0.05 per day from December 20, 2019 until the date judgment is paid pursuant to 28 U.S.C. § 1961(a).
5. Summit's request for attorney fees and costs is **DENIED without prejudice**. Within 14 days of this Order, Summit may renew its request for attorney fees and costs with appropriate documentation allowing this Court to determine with a high degree of certainty that the fees and costs asserted were actually and reasonably expended. If Summit does not timely file a renewed request, the Court will then terminate this action.

IT IS SO ORDERED.

Date: 7/19/2021

s/Timothy S. Black
Timothy S. Black
United States District Judge