

EXHIBIT H



US005548272A

United States Patent [19]

[11] Patent Number: **5,548,272**

Clark

[45] Date of Patent: **Aug. 20, 1996**

[54] TALKING POSTER

4,934,079	6/1990	Hoshi	40/427
5,051,728	9/1991	Wang	340/573
5,309,519	3/1994	Park et al.	381/190
5,359,374	10/1994	Schwartz	354/76
5,480,156	1/1996	Doederlein et al.	273/237

[75] Inventor: **Aaron D. Clark**, Reynoldsburg, Ohio

[73] Assignee: **Inotrend, Inc.**, Reynoldsburg, Ohio

[21] Appl. No.: **402,195**

Primary Examiner—Brent A. Swarthout
Assistant Examiner—Julie B. Lieu
Attorney, Agent, or Firm—Standley & Gilcrest

[22] Filed: **Mar. 10, 1995**

[51] Int. Cl.⁶ **H04B 3/36**

[57] **ABSTRACT**

[52] U.S. Cl. **340/407.1; 340/286.11;**
340/384.1; 340/384.7; 340/328; 40/455;
40/906

A talking poster is disclosed. The present invention is a novel method and apparatus for providing a material piece for housing the sound components, that incorporates the poster artwork. The material piece is painted with a portion of the artwork from the poster and lithographed in solid white on the reverse of the material piece. The material piece is then vacuum formed to the desired shape and adhered to the poster at the proper location with the hardware concealed within it.

[58] Field of Search 340/407.1, 286.11,
340/328, 384.1, 384.7; 40/455, 457, 463,
906, 717, 124.1

[56] **References Cited**

U.S. PATENT DOCUMENTS

3,978,598	9/1976	Rose et al.	40/106.52
4,299,041	11/1981	Wilson	40/124.1

5 Claims, 2 Drawing Sheets

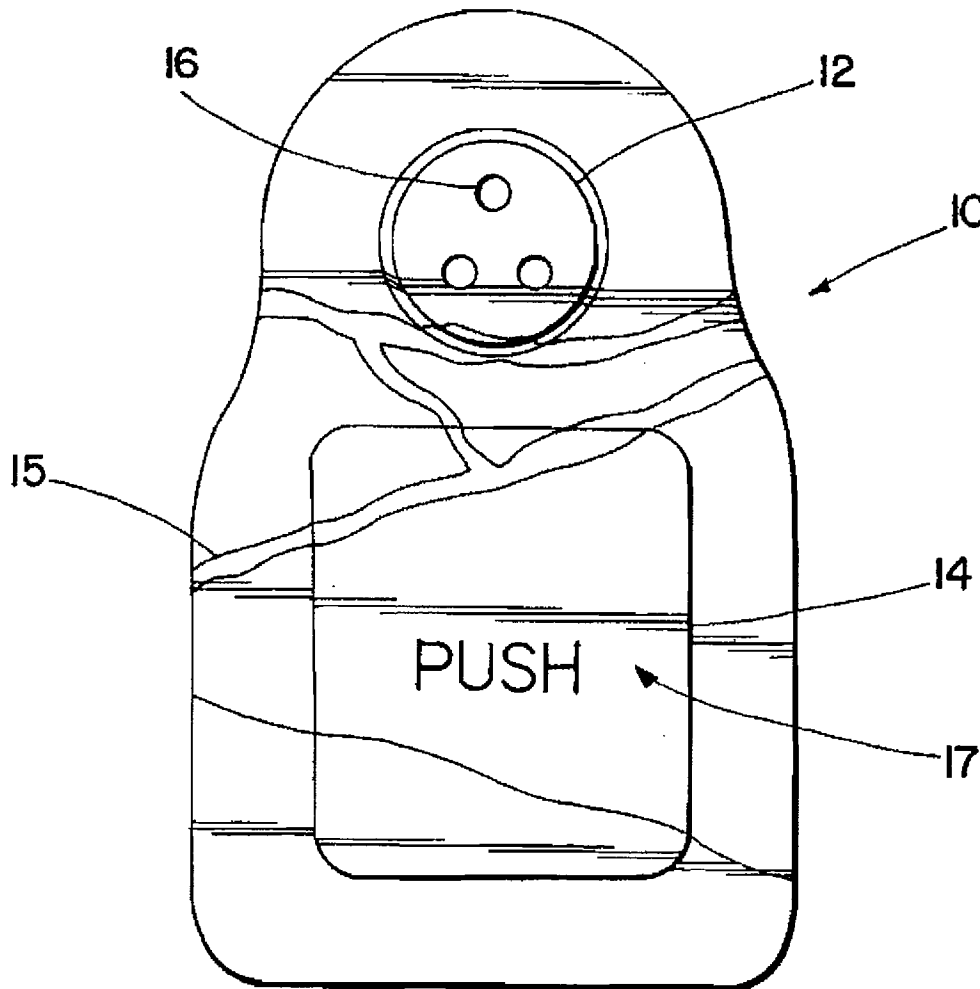

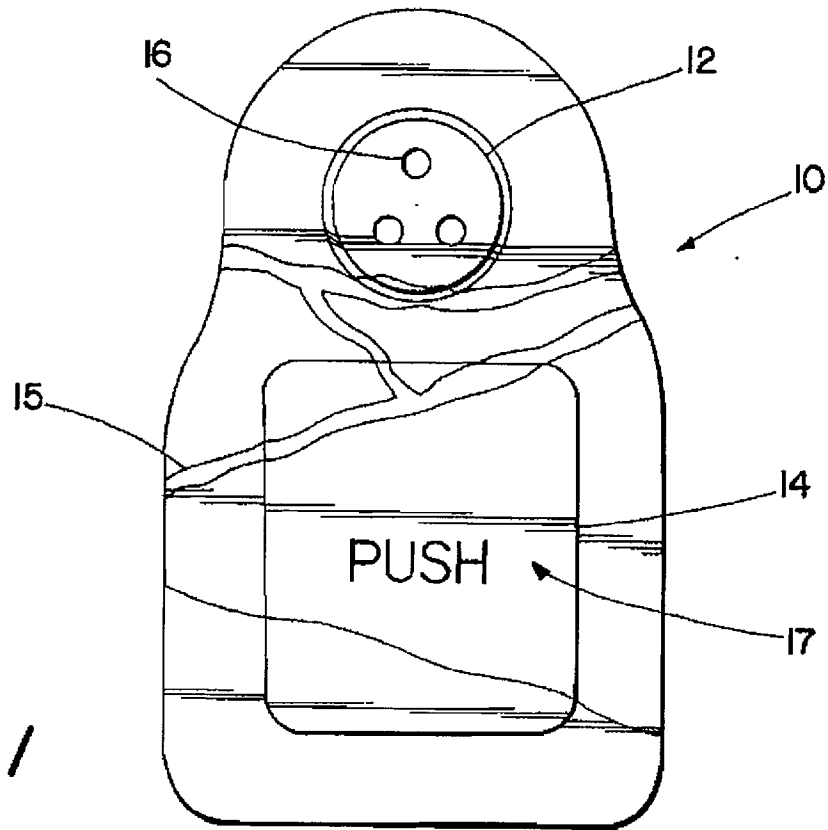

Fig. 1

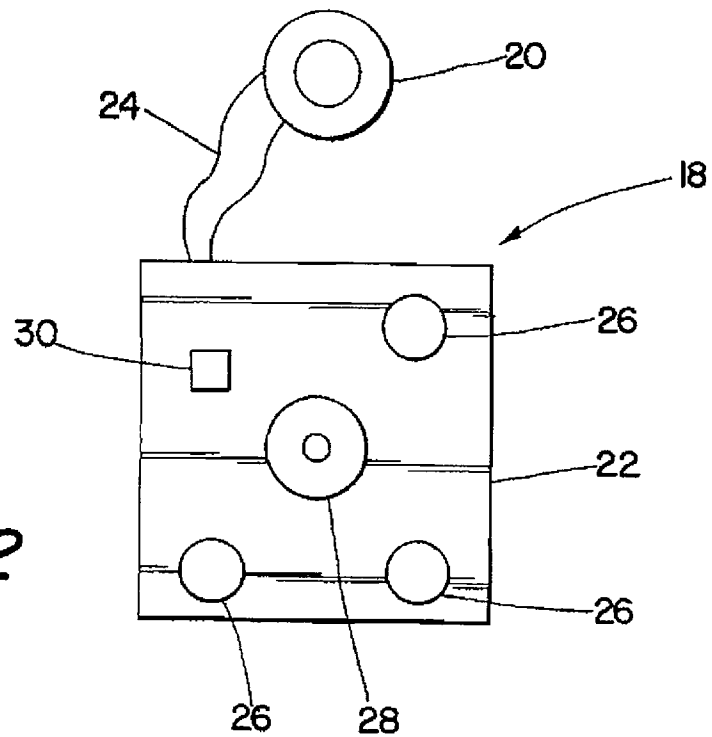

Fig. 2

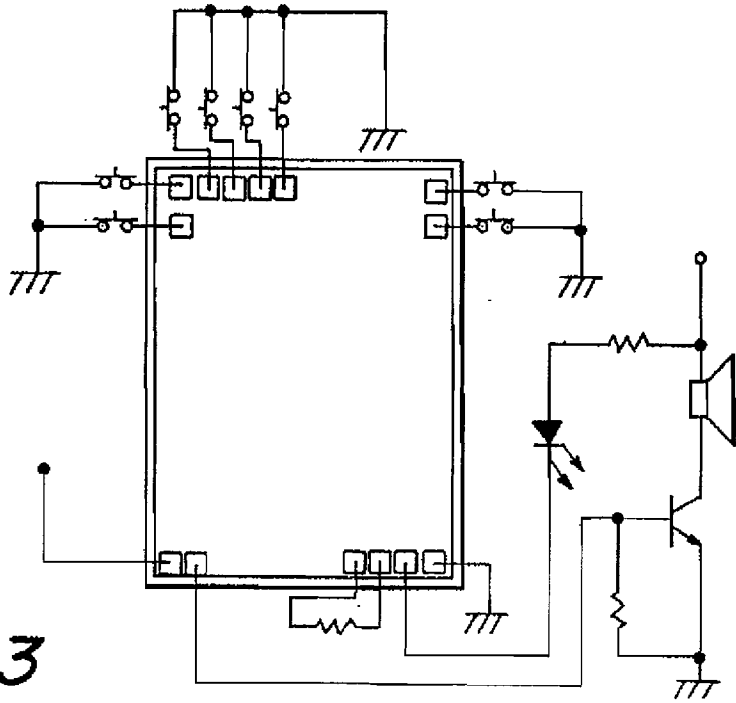

Fig. 3

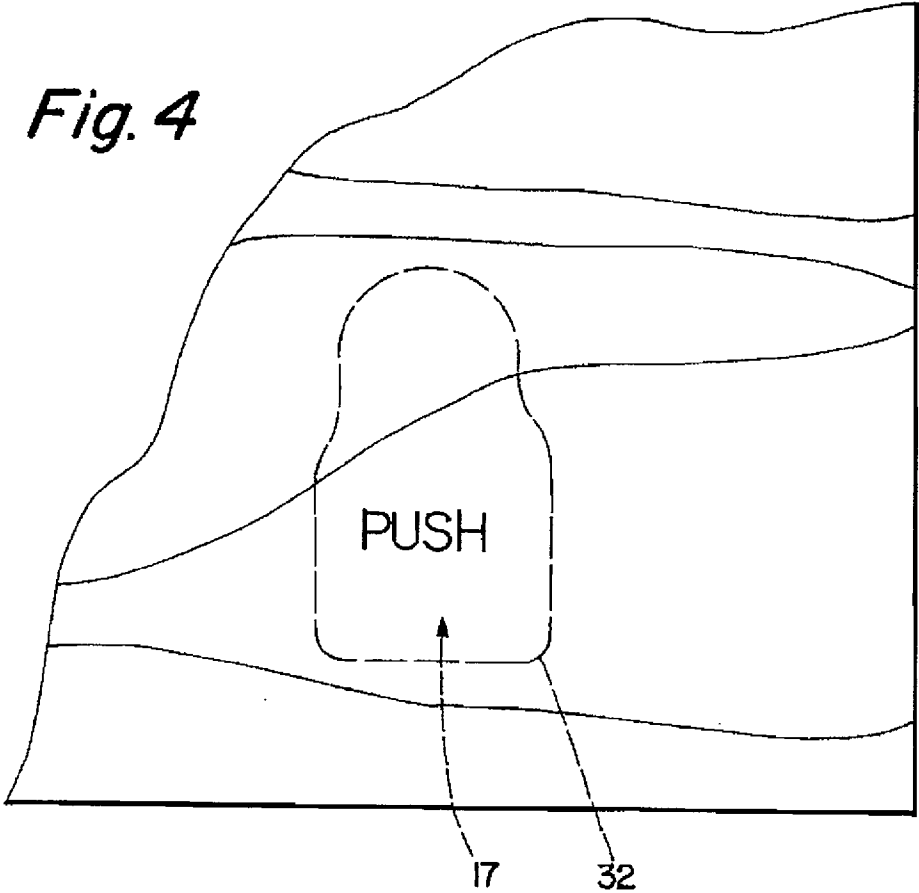

Fig. 4

1

TALKING POSTER

BACKGROUND AND SUMMARY OF THE INVENTION

The present invention relates generally to the art of posters and more particularly to a talking poster that projects a recorded sound using a device that is attached to the poster with material that is painted to match the color scheme of the poster art.

Poster sales are primarily dependent upon the novelty and attraction of individual posters. Posters must not only contain subject matter that is appealing but must also be of high quality to be attractive to consumers.

The present invention offers novel features to enable talking posters. The present invention is a novel method and apparatus for providing sound techniques under a material that incorporates the poster artwork into the material. A preferred material is blister pack. The blister pack material is painted with a portion of the artwork from the poster and lithographed in solid white on the blister pack material. The material is then vacuum formed to the desired shape and adhered to the poster at the proper art location, with the sound hardware concealed within it.

The use of the present invention allows the material covering the sound hardware to be placed anywhere on the surface of the poster artwork. The present invention also allows conventional posters to be adapted for sound, where it was previously considered impossible.

Other principal features and advantages of the invention will become apparent to those skilled in the art upon review of the following detailed description, claims and drawings.

BRIEF DESCRIPTION OF THE DRAWINGS

The various features and advantages of the present invention may be more readily understood with reference to the following detailed description taken in conjunction with the accompanying drawings, wherein like reference numerals designate like structural elements, and in which:

FIG. 1 is a plan view of a material piece of the present invention for covering sound hardware on a poster;

FIG. 2 is a plan view of one preferred embodiment of an electrical circuit of the present invention;

FIG. 3 is a schematic view of an application circuit for one preferred embodiment of a speech chip of the present invention; and

FIG. 4 is a cutaway view of a talking poster of the present invention.

DESCRIPTION OF THE PREFERRED EMBODIMENT(S)

The present invention is designed to provide a poster with a prerecorded message that may be played back on command. The invention uniquely provides the poster with the sound equipment without interfering with the artwork on the poster. FIG. 1 shows a plan view of a material piece 10 of the present invention. Material piece 10 is shown in its vacuum formed shape with raised surfaces at 12 and 14. Raised surface 12 may be used to contain and conceal a speaker and may allow the sound to emanate through holes 16. Raised surface 14 may be used to contain and conceal a circuit board. The uneven and broken lines 15 shown on the face of material piece 10 exemplify portions of poster

2

artwork. An indication 17 may be used to indicate where one may trigger the sound mechanism of the present invention.

FIG. 2 is a plan view of an electric circuit 18 of the present invention. Circuit 18 may include a speaker 20 attached to a circuit board 22 with wires 24. One or more batteries 26 may be used to power the circuit and a push button switch 28 may be used to trigger the sounds. Speech chip 30 may be used to control the circuit with the necessary logic.

FIG. 3 is a schematic of an embodiment of the present invention that utilizes a speech chip. The speech chip may be a Holtek model HT-81400 or a comparable model.

FIG. 4 is a cutaway view of the present invention as applied to a poster. An outline of the material piece is shown in dashed lines at 32 to indicate that the material piece may not be visible on the poster except on close inspection. Indication 17 may be visible to indicate how one may trigger the playback of the recorded sounds.

The following is one example method for constructing a preferred embodiment of the invention. The material piece, comprised of blister pack material, preferably comprises 0.010" thick clear PVC sheet. This sheet of material may be lithographed using a multi-color process printing technology to match the poster artwork. When finished, the material piece will artistically fit onto the poster, without any disruption in the poster artwork. In other words, the material piece will have the exact coloring and artwork on it, as would the space on the poster board where the piece resides, if the material piece was not present. The sheet is preferably printed on its second surface in reverse. This means that when the sheet is viewed from the front the ink will be on the back side of the sheet. The outer blister pack material also protects the paint from scratches, marring, etc. during use. After the poster artwork is applied a coat of white ink may be applied to enhance the printing and to keep the artwork ink from sticking to the molds, which may be made of a high temperature aluminum filled epoxy.

The blister pack material may then be vacuum-formed to achieve the desired final configuration. Preferably, the forming is accomplished by clamping the sheet in a frame and heating it with a radiant heat oven to approximately 240 degrees Fahrenheit. After reaching the desired forming temperature, the sheet is pliable and may be pulled down over the molds. A vacuum may be applied to assist the material in conforming to the shape of the mold. Cooling fans may be used to cool the sheet while on the molds until the material is rigid enough to remove from the molds.

While the sheet is still in the mold, a piece of double-sided adhesive material may be adhered to the back side of the sheet. The sheet may then be placed in a steel rule die and cut to conform to the desired shape of the product.

The scope of the invention is not to be considered limited by the above disclosure, and modifications are possible without departing from the spirit of the invention as evidenced by the following claims.

What is claimed is:

1. An assembly, comprising:

a poster comprised of a first material, said poster having a first surface, said first surface including poster art thereon;

a housing comprised of a second material, said housing attached to a portion of said first surface of said poster;

a speaker concealed between said housing and said first surface of said poster;

an electric circuit including a sound production component, operatively connected to said speaker and con-

3

- cealed between said housing and said first surface of said poster;
- a trigger attached to said electric circuit and concealed within said housing, said trigger adapted to be actuated through said housing to produce said sound;
- wherein a surface of said housing is prepared with a matching art which is substantially the same as that area of said poster art which appears on said portion of said poster that said housing covers when said housing is attached to said poster, such that said housing artistically blends in with the surrounding poster art that is not covered by said housing.
2. The talking poster of claim 1, wherein said electric circuit comprises:
- a circuit board;
 - at least one battery attached to said circuit board; and
 - a speech chip.
3. The assembly of claim 1, wherein said second material is a blister pack material.
4. The assembly of claim 3, wherein said matching art on said blister pack is printed on the surface of said blister pack that faces said poster when said assembly is assembled.

4

5. A method for making a talking poster, comprising the steps of:
- providing a poster with poster art on a first surface thereof;
 - providing human actuatable sound components adapted to be contained on said poster;
 - providing a housing adapted to be secured onto a portion of said first surface of said poster;
 - applying matching art to said housing which is substantially the same as that area of said poster art which appears on said portion of said poster that said housing covers when said housing is attached to said poster, such that said housing artistically blends in with the surrounding poster art that is not covered by said housing; and
 - securing said housing onto said portion of said first surface of said poster, such that said housing conceals said sound components.

* * * * *

UNITED STATES PATENT AND TRADEMARK OFFICE
CERTIFICATE OF CORRECTION

PATENT NO. :5,548,272

DATED : August 20, 1996

INVENTOR(S) :Aaron D. Clark

It is certified that error appears in the above-identified patent and that said Letters Patent is hereby corrected as shown below:

In column 3, line 8, please delete the word "arca" and replace it with
--area--.

Signed and Sealed this
Twelfth Day of November, 1996

Attest:



BRUCE LEHMAN

Attesting Officer

Commissioner of Patents and Trademarks

IA 7144941



THE UNITED STATES OF AMERICA

TO ALL TO WHOM THESE PRESENTS SHALL COME;

UNITED STATES DEPARTMENT OF COMMERCE

United States Patent and Trademark Office

August 29, 2008

THIS IS TO CERTIFY THAT ANNEXED HERETO IS A TRUE COPY FROM THE RECORDS OF THE UNITED STATES PATENT AND TRADEMARK OFFICE OF THOSE PAPERS OF THE BELOW IDENTIFIED PATENT APPLICATION THAT MET THE REQUIREMENTS TO BE GRANTED A FILING DATE UNDER 35 USC 111.

APPLICATION NUMBER: 08/402,195

FILING DATE: March 10, 1995

THE COUNTRY CODE AND NUMBER OF YOUR PRIORITY APPLICATION, TO BE USED FOR FILING ABROAD UNDER THE PARIS CONVENTION, IS US08/402,195

**By Authority of the
Under Secretary of Commerce for Intellectual Property
and Director of the United States Patent and Trademark Office**



**M. SIAS
Certifying Officer**



Case Docket No. 1104-002

THE COMMISSIONER OF PATENTS AND TRADEMARKS
Washington, D.C. 20531

Sir:

Transmitted herewith for filing is the patent application of:

Inventor: Aaron D. Clark

For: A TALKING POSTER

Enclosed are:

- 3 sheets of drawings
- An assignment of the invention to
- An assignment recordation cover sheet
- A declaration and power of attorney
- Verified Small Entity Statement - Individual

The filing fee has been calculated as shown below:

- SMALL ENTITY
- LARGE ENTITY

Basic Fee		\$ 365.00
<u>Total Claims</u>		
Number Over 20 (if < 20=0)	0 x 11 =	\$ 0.00
<u>Independent Claims</u>		
Number Over 3 (if < 3=0)	0 x 38 =	\$ 0.00
Total Filing Fee		<u>\$ 365.00</u>

A check in the amount of \$365.00 to cover the filing fee is enclosed. Any deficiency in this fee or any overpayment is to be charged/credited to the Deposit Account of Standley & Gilcrest, Deposit Account No. 19-4076. Triplicate copies of this sheet are attached.

March 10, 1995
(Date)

Jeffrey S. Standley
Jeffrey S. Standley
Registration No. 34,021
Attorney for Applicant



APPLICATION FOR UNITED STATES LETTERS PATENT

for

A TALKING POSTER

Inventor: Aaron D. Clark

Assignee: Inotrend, Inc.
Reynoldsburg, Ohio

Attorneys: Standley & Gilcrest
Attn: Jeffrey S. Standley
555 Metro Place North
Suite 500
Dublin, Ohio 43017
Phone: (614) 792-5555



365, 200/402195 A

A TALKING POSTER

Inventor: Aaron D. Clark

BACKGROUND AND SUMMARY OF THE INVENTION

5 The present invention relates generally to the art of posters and more particularly to a
talking poster that projects a recorded sound using a device that is attached to the poster with
material that is painted to match the color scheme of the poster art.

Poster sales are primarily dependent upon the novelty and attraction of individual posters.
Posters must not only contain subject matter that is appealing but must also be of high quality to
10 be attractive to consumers.

The present invention offers novel features to enable talking posters. The present
invention is a novel method and apparatus for providing sound techniques under a material that
incorporates the poster artwork into the material. A preferred material is blister pack. The blister
pack material is painted with a portion of the artwork from the poster and lithographed in solid
15 white on the blister pack material. The material is then vacuum formed to the desired shape and
adhered to the poster at the proper art location, with the sound hardware concealed within it.

The use of the present invention allows the material covering the sound hardware to be
placed anywhere on the surface of the poster artwork. The present invention also allows
conventional posters to be adapted for sound, where it was previously considered impossible.

20 Other principal features and advantages of the invention will become apparent to those
skilled in the art upon review of the following detailed description, claims and drawings.

BRIEF DESCRIPTION OF THE DRAWINGS

The various features and advantages of the present invention may be more readily understood with reference to the following detailed description taken in conjunction with the accompanying drawings, wherein like reference numerals designate like structural elements, and in which:

Figure 1 is a plan view of a material piece of the present invention for covering sound hardware on a poster;

Figure 2 is a plan view of one preferred embodiment of an electrical circuit of the present invention;

Figure 3 is a schematic view of an application circuit for one preferred embodiment of a speech chip of the present invention; and

Figure 4 is a cutaway view of a talking poster of the present invention.

DESCRIPTION OF THE PREFERRED EMBODIMENT(S)

The present invention is designed to provide a poster with a prerecorded message that may be played back on command. The invention uniquely provides the poster with the sound equipment without interfering with the artwork on the poster. Figure 1 shows a plan view of a material piece 10 of the present invention. Material piece 10 is shown in its vacuum formed shape with raised surfaces at 12 and 14. Raised surface 12 may be used to contain and conceal a speaker and may allow the sound to emanate through holes 16. Raised surface 14 may be used to contain and conceal a circuit board. The uneven and broken lines 15 shown on the face of material piece 10 exemplify portions of poster artwork. An indication 17 may be used to indicate where one may trigger the sound mechanism of the present invention.

Figure 2 is a plan view of an electric circuit 18 of the present invention. Circuit 18 may include a speaker 20 attached to a circuit board 22 with wires 24. One or more batteries 26 may be used to power the circuit and a push button switch 28 may be used to trigger the sounds. Speech chip 30 may be used to control the circuit with the necessary logic.

5 Figure 3 is a schematic of an embodiment of the present invention that utilizes a speech chip. The speech chip may be a Holtek model HT-81400 or a comparable model.

Figure 4 is a cutaway view of the present invention as applied to a poster. An outline of the material piece is shown in dashed lines at 32 to indicate that the material piece may not be visible on the poster except on close inspection. Indication 17 may be visible to indicate how one
10 may trigger the playback of the recorded sounds.

The following is one example method for constructing a preferred embodiment of the invention. The material piece, comprised of blister pack material, preferably comprises .010" thick clear PVC sheet. This sheet of material may be lithographed using a multi-color process printing technology to match the poster artwork. When finished, the material piece will artistically
15 fit onto the poster, without any disruption in the poster artwork. In other words, the material piece will have the exact coloring and artwork on it, as would the space on the poster board where the piece resides, if the material piece was not present. The sheet is preferably printed on its second surface in reverse. This means that when the sheet is viewed from the front the ink will be on the back side of the sheet. The outer blister pack material also protects the paint from scratches, marring, etc. during use. After the poster artwork is applied a coat of white ink may
20 be applied to enhance the printing and to keep the artwork ink from sticking to the molds, which may be made of high temperature aluminum filled epoxy.

The blister pack material may then be vacuum-formed to achieve the desired final configuration. Preferably, the forming is accomplished by clamping the sheet in a frame and

heating it with a radiant heat oven to approximately 240 degrees Fahrenheit. After reaching the desired forming temperature, the sheet is pliable and may be pulled down over the molds. A vacuum may be applied to assist the material in conforming to the shape of the mold. Cooling fans may be used to cool the sheet while on the molds until the material is rigid enough to remove
5 from the molds.

While the sheet is still in the mold, a piece of double-sided adhesive material may be adhered to the back side of the sheet. The sheet may then be placed in a steel rule die and cut to conform to the desired shape of the product.

The scope of the invention is not to be considered limited by the above disclosure, and
10 modifications are possible without departing from the spirit of the invention as evidenced by the following claims.

WHAT IS CLAIMED IS:

1. A talking poster, comprising:

a poster;

5 a blister pack attached to said poster, wherein said blister pack is adapted to house a speaker and an electric circuit, wherein said blister pack matches the artwork of the poster to which it is attached;

a speaker concealed between said blister pack and said poster; and

an electric circuit operatively connected to said speaker and concealed between said blister pack and said poster.

10 2. The talking poster of claim 1, wherein said electric circuit comprises:

a circuit board;

at least one battery attached to said circuit board;

a trigger attached to said circuit board; and

a speech chip.

15 3. The talking poster of claim 1, wherein said blister pack comprises blister pack material with at least one coat of paint to match the artwork of the poster and a coat of white paint.

4. The talking poster of claim 1, wherein said blister pack has a hole therein to allow sound to pass.

20 5. The talking poster of claim 1, wherein said blister pack comprises blister pack material with artwork paint that matches the poster artwork on the side of the material that faces the poster.

6. The talking poster of claim 5 further comprising a coat of white paint on the artwork paint.

7. The talking poster of claim 5 further comprising double-sided adhesive material between said blister pack and said poster to adhere said blister pack to said poster.

8. A method for making a talking poster, comprising the steps of:

providing a poster;

5 printing a portion of the artwork on said poster on blister pack material;

printing a layer of white on said blister pack material;

vacuum forming said blister pack material to accomodate an electric circuit;

nesting an electric circuit in said blister pack material; and

attaching said blister pack material to said poster.

10 9. The method of claim 8, wherein said artwork and said layer of white is printed on the surface of said blister pack material that faces said poster.

10. The method of claim 8, further comprising cutting said blister pack material into a desired shape after printing said layer of white.

15 11. The method of claim 8, further comprising adhering double-sided adhesive to said blister pack material after vacuum forming.

A TALKING POSTER

ABSTRACT OF THE INVENTION

5 A talking poster is disclosed. The present invention is a novel method and apparatus for providing a material piece for housing the sound components, that incorporates the poster artwork. The material piece is painted with a portion of the artwork from the poster and lithographed in solid white on the reverse of the material piece. The material piece is then vacuum formed to the desired shape and adhered to the poster at the proper location with the hardware
10 concealed within it.

CERTIFICATE OF MAILING BY EXPRESS MAIL

"Express Mail" number TB238500342US
Date of Deposit NOV 10, 1995

I hereby certify that this correspondence was deposited with the United States Postal Service **EXPRESS MAIL** Post Office to Addressee service under 37 CFR 1.10 on the date indicated above and is addressed to the Commissioner of Patents and Trademarks, Washington, D.C. 20231.

Levi A. Kessen
Levi A. Kessen
(Signature of person mailing paper or fee)



Applicant: Aaron D. Clark
 Attorney's Serial No.: 1104-002
 Serial No.: Not yet assigned
 Filed: March 10, 1995
 For: A TALKING POSTER

VERIFIED STATEMENT (DECLARATION) CLAIMING SMALL ENTITY STATUS (37 CFR 1.27(A)) - INDIVIDUAL

As a below named inventor, I hereby declare that I qualify as an independent inventor as defined in 37 CFR 1.9(c) for purposes of paying reduced fees under section 41(a) and (b) of Title 35, United States Code, to the Patent and Trademark Office with regard to the invention entitled A TALKING POSTER by inventor, Aaron D. Clark, described in:

the specification filed herewith
 application Serial No. _____, filed _____

I have not assigned, granted, conveyed or licensed and am under no obligation under contract or law to assign, grant, convey or license, any rights in the invention to any person who could not be classified as an independent inventor under 37 CFR 1.9(c) if that person had made the invention, or to any concern which would not qualify as a small business concern under 37 CFR 1.9(d) or a nonprofit organization under 37 CFR 1.9(e).

Each person, concern or organization to which I have assigned, granted, conveyed, or licensed or am under an obligation under contract or law to assign, grant, convey, or license any rights in the invention is listed below:

*NOTE: Separate verified statements are required from each named person, concern or organization having rights to the invention averring to their status as small entities. (37 CFR 1.27)

NAME _____
 ADDRESS _____

INDIVIDUAL SMALL BUSINESS CONCERN NONPROFIT ORGANIZATION

I acknowledge the duty to file, in this application or patent, notification of any change in status resulting in loss of entitlement to small entity status prior to paying, or at the time of paying, the earliest of the issue fee or any maintenance fee due after the date on which status as a small entity is no longer appropriate (37 CFR 1.28(b)).

I hereby declare that all statements made herein of my own knowledge are true and that all statements made on information and belief are believed to be true; and further that these statements were made with the knowledge that willful false statements and the like so made are punishable by fine or imprisonment, or both, under Section 1001 of Title 18 of the United States Code, and that such willful false statements may jeopardize the validity of the application, any patent issuing thereon, or any patent to which this verified statement is directed.

NAME OF PERSON SIGNING Aaron D. Clark

ADDRESS OF PERSON SIGNING 6453 Helm Court, Reynoldsburg, Ohio 43068

SIGNATURE *Aaron D. Clark*

DATE 3/10/95

CERTIFICATE OF MAILING BY EXPRESS MAIL

"Express Mail" number DB22330034245
Date of Deposit March 10, 1995

I hereby certify that this correspondence was deposited with the United States Postal Service "EXPRESS MAIL" Post Office to Addressee service under 37 CFR 1.10 on the date indicated above and is addressed to the Commissioner of Patents and Trademarks, Washington, D.C. 20231.

For A. Kessen
For A. Kessen
(Signature of person mailing paper or fee)

DECLARATION
AND
POWER OF ATTORNEY

I, the below named inventor, hereby declare that:

My residence, post office addresses and citizenship are as stated below next to my name.

I believe I am the original, first and sole inventor of the subject matter which is claimed and for which a patent is sought on the invention entitled **A TALKING POSTER** the specification of which

(check one) is attached hereto.

was filed on _____ as
Application Serial No. _____
and was amended on _____ (if applicable)

I hereby state that I have reviewed and understand the contents of the above identified specification, including the claims, as amended by any amendment referred to above.

I acknowledge the duty to disclose information which is material to the patentability of the invention claimed in this application, in accordance with Title 37, Code of Federal Regulations, §1.56(a) and (b).

I hereby claim foreign priority benefits under Title 35, United States Code, §119 of any foreign application(s) for patent or inventor's certificate listed below and have also identified below any foreign application for patent or inventor's certificate having a filing date before that of the application on which priority is claimed:

Prior Foreign Application(s)

			<u>Priority</u> <u>Claimed</u>	
_____ (Number)	_____ (Country)	_____ (Day/Month/Year Filed)	<input type="checkbox"/> Yes	<input type="checkbox"/> No
_____ (Number)	_____ (Country)	_____ (Day/Month/Year Filed)	<input type="checkbox"/> Yes	<input type="checkbox"/> No
_____ (Number)	_____ (Country)	_____ (Day/Month/Year Filed)	<input type="checkbox"/> Yes	<input type="checkbox"/> No

I hereby claim the benefit under Title 35, United States Code, §120 of any United States application(s) listed below and, insofar as the subject matter of each of the claims of this application is not disclosed in the prior United States application in the manner provided by the first paragraph of Title 35, United States Code, §112, we acknowledge the duty to disclose material information as defined in Title 37, Code of Federal Regulation, §1.56(a) and (b) which occurred between the filing date of the prior application and the national or PCT international filing date of this application:

(Application Serial No.)	(Filing Date)	(Status) (patented, pending abandoned)

(Application Serial No.)	(Filing Date)	(Status) (patented, pending abandoned)

I hereby appoint Jeffrey S. Standley, Reg. No. 34,021 and/or Roger A. Gilcrest, Registration No. 31,954, c/o Standley & Gilcrest, 555 Metro Place North, Suite 500, Dublin, Ohio 43017, Telephone No. (614) 792-5555 our attorneys, with full power in each of them, of substitution and revocation, to prosecute this application and to transact all business in the Patent and Trademark Office connected therewith. All correspondence should be sent to the attention of Jeffrey S. Standley at the address above.

I hereby declare that all statements made herein of our own knowledge are true and that all statements made on information and belief are believed to be true; and further that these statements were made with the knowledge that willful false statements and the like so made are punishable by fine or imprisonment, or both, under Section 1001 of Title 18 of the United States Code and that such willful false statements may jeopardize the validity of the application of any patent issued thereon.

Full name of inventor Aaron D. Clark
183 Aaron D. Clark

Date 3/10/95

Residence Reynoldsburg, Ohio OH

Citizenship United States of America

Post Office Address 6453 Helm Court, Reynoldsburg, Ohio 43068

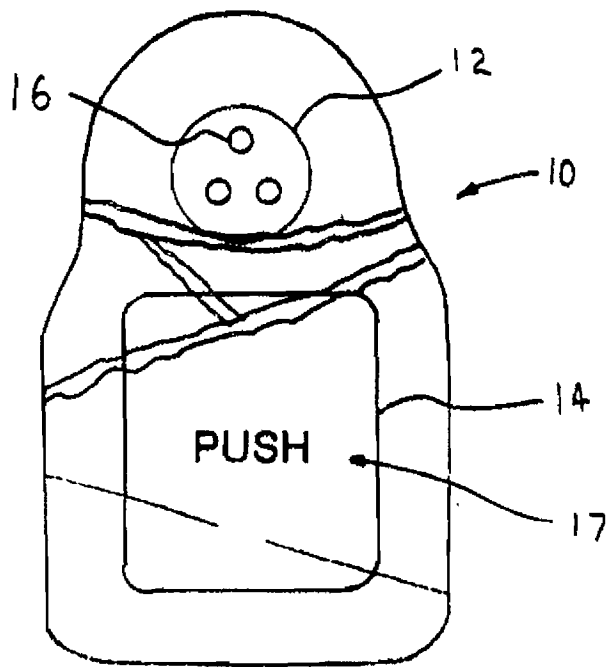
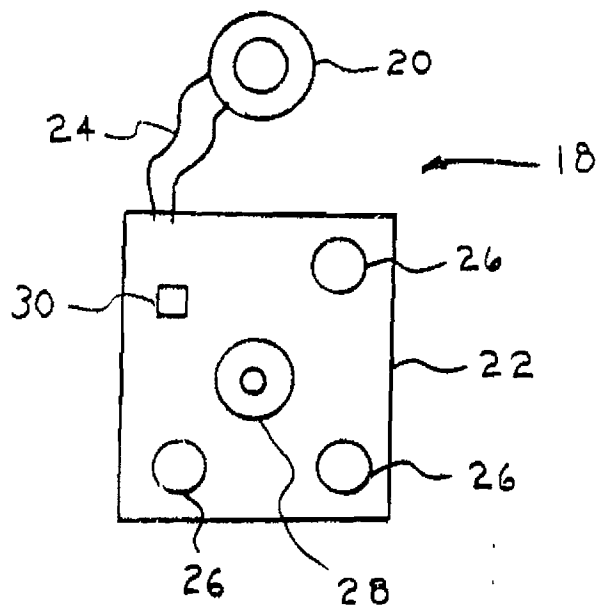

FIG. 1



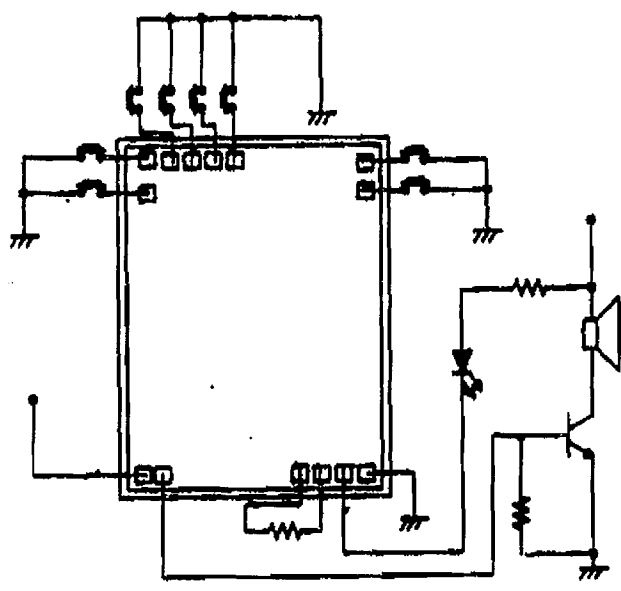

FIG. 3

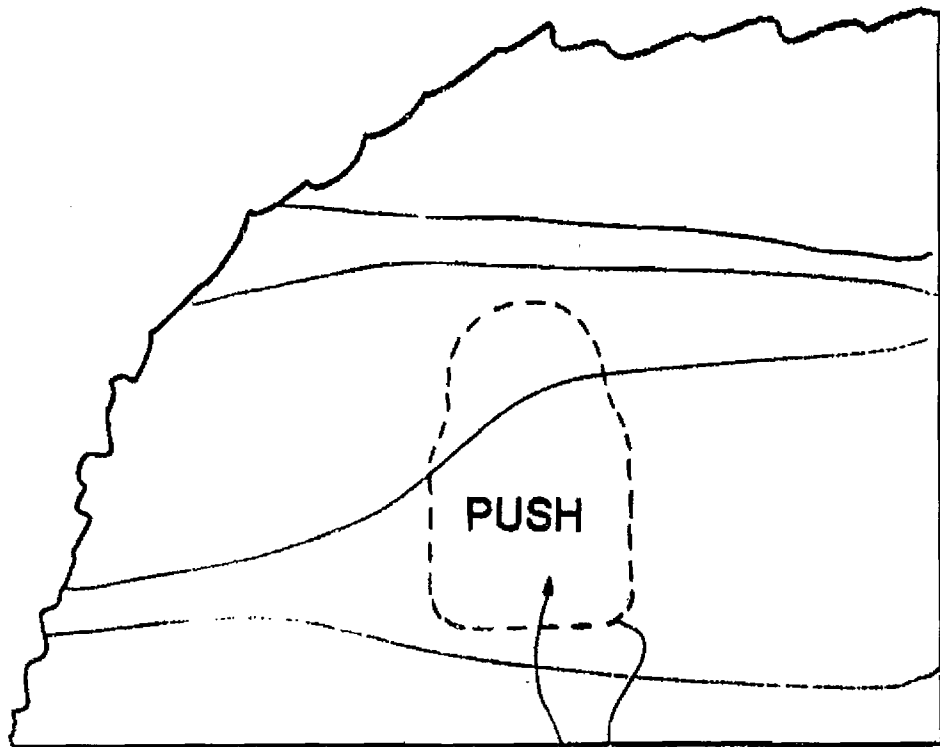

FIG. 4