

### REASONS FOR ALLOWANCE

1. The following is an examiner's statement of reasons for allowance:

U.S. Patent No. 5,821,069 discloses a method and a system which make reliable forecasting of the traffic flows at selected locations or in selected sections of a road network possible and thereby permit, in particular, effective traffic direction and guiding of vehicles to their destinations. to communicate with all of the vehicle control units and with passenger telephones. U.S. Patent No. discloses a method is provided for processing position and travel related information through a data processing station on a data network. In one embodiment, a GPS receiver is used to obtain a measured position fix of a mobile unit. The measured position fix is reported to the data processing station which associates the reported position to a map of the area. Typically, the measured position of the mobile unit is marked and identified by a marker on the map. The area map is then stored in the data processing station and made available for access by authorized monitor units or mobile units. An authorized monitor unit may request for a specific area map by sending a request through the data network. Upon receiving a request, the data processing unit sends the area map to the monitor unit. Data processing station may also perform a database search for travel-related information, such as directions to a gasoline station.

None of the above-cited references either singularly or in combination teach or fairly disclose:

Art Unit: 3661

"wherein said computer system has a map database, and said computer system, in response to said request for information, transmits map information representative of a portion of said map database, and said map information representative of said map database is displayed graphically together with said traffic information".

"at least one of said mobile user stations providing a request to said computer system for information together with a respective location of said mobile user stations, and in response thereto, said computer system providing to said one of said mobile user stations information representative of selected portions of said map database and selected portions of said traffic information database based on said respective geographic location of said one of said mobile user stations."

2. Any comments considered necessary by applicant must be submitted no later than the payment of the issue fee and, to avoid processing delays, should preferably accompany the issue fee. Such submissions should be clearly labeled "Comments on Statement of Reasons for Allowance."

Any inquiry concerning this communication or earlier communications from the examiner should be directed to Marthe Y Marc-Coleman whose telephone number is (703) 305-4970. The examiner can normally be reached on Monday-Thursday from 9:30 AM - 8:00 PM.

If attempts to reach the examiner by telephone are unsuccessful, the examiner's supervisor, William A Cuchlinski can be reached on (703) 308-3873. The fax phone numbers for the organization where this application or proceeding is assigned are (703)

Art Unit: 3661

305-7687 for regular communications and (703) 305-7687 for After Final communications.

Any inquiry of a general nature or relating to the status of this application or proceeding should be directed to the receptionist whose telephone number is (703) 308-1113.

Patent Examiner  
MYM  
Marthe Marc-Coleman



WILLIAM A. CUCHLINSKI, JR.  
SUPERVISORY PATENT EXAMINER  
TECHNOLOGY CENTER 3600

February 19, 2002



UNITED STATES PATENT AND TRADEMARK OFFICE

UNITED STATES DEPARTMENT OF COMMERCE  
United States Patent and Trademark Office  
Address: COMMISSIONER OF PATENTS AND TRADEMARKS  
Washington, D.C. 20231  
www.uspto.gov

APPLICATION NO.	FILING DATE	FIRST NAMED INVENTOR	ATTORNEY DOCKET NO.	CONFIRMATION NO.
09/550,476	04/14/2000	Bruce W. DeKock	BWD-7118.004	8794

7590 07/01/2002  
Bruce W DeKock  
1600 ODS Tower  
801 S W Second Avenue  
Portland, OR 97204

EXAMINER

MARC COLEMAN, MARTHE Y

ART UNIT PAPER NUMBER

3661

P# 11

DATE MAILED: 07/01/2002

Please find below and/or attached an Office communication concerning this application or proceeding.



**UNITED STATES DEPARTMENT OF COMMERCE**  
**Patent and Trademark Office**  
 Address: COMMISSIONER OF PATENTS AND TRADEMARKS  
 Washington, D.C. 20231

APPLICATION NUMBER	FILING DATE	FIRST NAMED APPLICANT	ATTORNEY DOCKET NO.
--------------------	-------------	-----------------------	---------------------

09/550, 476

EXAMINER
----------

ART UNIT	PAPER NUMBER
----------	--------------

P#11

DATE MAILED: 7/11/02

**NOTICE OF ABANDONMENT**

This application is abandoned in view of:

- Applicant's failure to timely file a proper response to the Office letter mailed on \_\_\_\_\_.
- A response (with a Certificate of Mailing or Transmission of \_\_\_\_\_) was received on \_\_\_\_\_, which is after the expiration of the period for response (including a total extension of time of \_\_\_\_\_ month(s)) which expired on \_\_\_\_\_.
- A proposed response was received on \_\_\_\_\_, but it does not constitute a proper response to the final rejection.  
 (A proper response to a final rejection consists only of: a timely filed amendment which places the application in condition for allowance; a Notice of Appeal; or the filing of a continuing application under 37 CFR 1.62 (FWC).

No response has been received.

Applicant's failure to timely pay the required issue fee within the statutory period of three months from the mailing date of the Notice of Allowance.

The issue fee (with a Certificate of Mailing or Transmission of \_\_\_\_\_) was received on \_\_\_\_\_.

The submitted issue fee of \$\_\_\_\_\_ is insufficient. The issue fee required by 37 CFR 1.18 is \$\_\_\_\_\_.

The issue fee has not been received.

Applicant's failure to timely file new formal drawings as required in the Notice of Allowability.

Proposed new formal drawings (with a Certificate of Mailing or Transmission of \_\_\_\_\_) were received on \_\_\_\_\_.

The proposed new formal drawings filed \_\_\_\_\_ are not acceptable.

No proposed new formal drawings have been received.

The express abandonment under 37 CFR 1.62(g) in favor of the FWC application filed on \_\_\_\_\_.

The letter of express abandonment which is signed by the attorney or agent of record, the assignee of the entire interest, or all of the applicants.

The letter of express abandonment which is signed by an attorney or agent (acting in a representative capacity under 37 CFR 1.34(a) upon the filing of a continuing application.

The decision by the Board of Patent Appeals and Interferences rendered on \_\_\_\_\_ and because the period for seeking court review of the decision has expired and there are no allowed claims.

The reason(s) below:

**ABANDONMENT**  
**CONTACT PERSON IS:**  
**TOM HAWKINS**  
 305-8380

COPY OF ORIGINALS FILED

#12 \$DAC

LAW OFFICES

CHERNOFF, VILHAUER, MCCLUNG & STENZEL, LLP

- \* JACOB E. VILHAUER, JR.
- \* DENNIS E. STENZEL
- \* CHARLES D. MCCLUNG
- \* DONALD B. HASLETT
- \* J. PETER STAPLES
- \* WILLIAM O. GENY
- \* NANCY J. MORIARTY
- \* JULIANNE R. DAVIS
- \* KEVIN L. RUSSELL

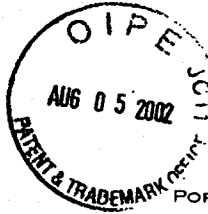

INTELLECTUAL PROPERTY LAW  
INCLUDING PATENT, TRADEMARK,  
COPYRIGHT AND UNFAIR  
COMPETITION MATTERS

1600 ODS TOWER  
601 S.W. SECOND AVENUE  
PORTLAND, OREGON 97204-3157  
TELEPHONE: (503) 227-5631  
FAX: (503) 228-4373

- \* TIM A. LONG
- \* KURT ROHLFS
- \* BRENNAN K. LEGAARD

\* REGISTERED PATENT ATTORNEY

DAVID S. FINE  
SENIOR LAW CLERK

DANIEL P. CHERNOFF  
(1935-1995)

July 30, 2002

Our File 7116.004

Box DAC  
Attention: Office of Petitions  
Commissioner for Patents  
Washington, D.C. 20231

Re: United States Patent Application Serial No. 09/550,476  
For: SYSTEM FOR PROVIDING TRAFFIC INFORMATION  
Filed: April 14, 2000

Dear Sir:

Enclosed for filing is a Petition for Revival of an Application for Patent Abandoned Unintentionally under 37 U.S.C. 1.137 (b). Additionally, we enclose copies of the Issue Fee Due Notice and fourteen sheets of the new formal drawings both dated July 30, 2002, and which have been filed with the appropriate authority. Also enclosed is our check payable to the Commissioner for Patents for the Petition to Revive in the current amount of \$640 for a small entity and an acknowledgment postcard.

Please charge Deposit Account No. 03-1550 for any additional fees which may be required or credit any over payments to that account. A duplicate copy of this transmittal letter is enclosed.

Respectfully submitted,

Kevin L. Russell

KLR:djs  
Enclosures

RECEIVED

AUG 07 2002

OFFICE OF PETITIONS

**PETITION FOR REVIVAL OF AN APPLICATION FOR PATENT  
ABANDONED UNINTENTIONALLY UNDER 37 U.S.C. 1.137(B)**

Docket No.  
KLR 7116.004



Applicant: DeKock, et al.

Group Art Unit: 3661

Serial No.: 09/550,476

Examiner: Coleman

Filed: April 14, 2000

Title: **SYSTEM FOR PROVIDING TRAFFIC INFORMATION**

July 30, 2002

Box DAC  
Attention: Office of Petitions  
Commissioner of Patents  
Washington, D.C. 20231

The above-identified application became abandoned for failure to timely pay the issue fee within the statutory period from the mailing date. The abandonment date of this application is May 21, 2002.

**APPLICANT HEREBY PETITIONS  
FOR REVIVAL OF THIS APPLICATION**

1. **Petition fee**

- Small entity fee of \$640 (37 C.F.R. 1017(m))
- Small entity statement enclosed herewith.
- Small entity statement previously filed.
- Other than small entity fee \$ \_\_\_\_\_; (37 C.F.R. 1.17(m))

2. **Reply and/or fee**

A. The reply and/or fee to the above-noted Notice of Issue Fee Due:

- has been filed previously on \_\_\_\_\_, and
- A copy is enclosed herewith.

B. The issue fee of \$ 640 \_\_\_\_\_:

- has been paid previously on.
- A copy is enclosed herewith.

PETITION TO REVIVE

08/06/2002 AMONDAF1 00000038 09550476

01 FC:241

640.00 OP

**RECEIVED**

AUG 07 2002

OFFICE OF PETITIONS

Exhibit E

Page 267 of 311

267

COPY OF PAPERS  
ORIGINALLY FILED



ORIGINAL DOCUMENT PRINTED ON CHEMICAL REACTIVE PAPER WITH MICROPRINTED BORDER - SEE REVERSE SIDE FOR COMPLETE SECURITY FEATURES

**BERNOFF, VILHAUER, McCLUNG & STENZEL, LLP**  
1600 ODS TOWER  
601 S.W. SECOND AVENUE  
PORTLAND, OREGON 97204-3157

EXPLANATION	AMOUNT
Balance Debit	
Pat. 09/550,476	
SYSTEM FOR PROVIDING TRAFFIC INFORMATION	

24-22/1230

61082

The sum of **61082**

INT

TO THE ORDER OF	DESCRIPTION	CHECK NUMBER	CHECK AMOUNT
for Director of US Patent & Trademark Office	SYSTEM FOR PROVIDING TRAFFIC INFORMATION	61082	\$ 6,108.20

**usbank.** PORTLAND, OREGON



THIS DOCUMENT CONTAINS HEAT SENSITIVE INK. TOUCH OR PRESS HERE. RED IMAGE DISAPPEARS WITH HEAT.

**Receipt of the following is acknowledged in the USPTO:**

- Transmittal Letter to the USPTO;
- 2002 Transmittal Fee Form in duplicate;
- PTO Form PTOL-85 with certificate of mailing;
- Our Check in the amount of \$649;
- Copies of a Petition to Revive and Formal Drawings; and an Acknowledgment postcard.

Applicant: DeKock, et al.  
 Entitled: SYSTEM FOR PROVIDING TRAFFIC INFORMATION  
 Serial No.: 09/550,476

BWD 7116.004  
 KLR:djs  
 July 30, 2002

**RECEIVED**  
 AUG 07 2002  
 OFFICE OF PETITIONS

Exhibit E  
 Page 268 of 311



3. **Terminal disclaimer with a disclaimer fee**

- Since this utility/plant application was filed on or after June 8, 1995 no terminal disclaimer is required.
- A terminal disclaimer (and disclaimer fee (37 C.F.R. 1.20(d)) of \$ \_\_\_\_\_ for a small entity or \$ \_\_\_\_\_ for other than a small entity) equivalent to the number of months from abandonment to the filing of this petition is enclosed herewith.

4. **Statement:**

The entire delay in filing the required reply from the due date for the reply until the filing of a grantable petition under 37 C.F.R. 1.137(b) was unintentional.

Notes: Where a petition under 37 C.F.R. 1.137(b) is filed:

- (1) more than three months from the date the applicant is first notified that the application is abandoned explain (on an attached sheet) in detail the cause of the delay in filing the petition;
- (2) more than one year from the date of abandonment, explain (on an attached sheet) in detail how the delay in discovering the abandonment status occurred and indicate the date that applicant first became aware of the date of abandonment.

Dated: July 30, 2002

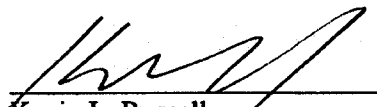
  
Kevin L. Russell  
Reg. No. 38,292  
Chernoff Vilhauer McClung & Stenzel  
1600 ODS Tower  
601 SW Second Avenue  
Portland, Oregon 97204  
Tel. No. (503) 227-5631

Enclosures:  Reply;  
 Fee Payment;  
 Copies of New Formal Drawings and Notice of Issue Fee Due; and an  
 Acknowledgment Postcard

#13

PART B - FEE(S) TRANSMITTAL

Complete and mail this form, together with applicable fee(s), to:

Box ISSUE FEE  
Assistant Commissioner for Patents  
Washington, D.C. 20231

MAILING INSTRUCTIONS: This form should be used for transmitting the ISSUE FEE and PUBLICATION FEE (if required). Blocks 1 through 4 should be completed where appropriate. All further correspondence including the Patent, advance orders and notification of maintenance fees will be mailed to the current correspondence address as indicated unless corrected below or directed otherwise in Block 1, by (a) specifying a new correspondence address; and/or (b) indicating a separate "FEE ADDRESS" for maintenance fee notifications.

CURRENT CORRESPONDENCE ADDRESS (Note: Legibly mark-up with any corrections or use Block 1)

7590 02/20/2002  
Bruce W DeKock  
1600 ODS Tower  
801 S W Second Avenue  
Portland, OR 97204



Note: The certificate of mailing below can only be used for domestic mailings of the Fee(s) Transmittal. This certificate cannot be used for any other accompanying papers. Each additional paper, such as an assignment or formal drawing, must have its own certificate of mailing.

Certificate of Mailing

I hereby certify that this Fee(s) Transmittal is being deposited with the United States Postal Service with sufficient postage for first class mail in an envelope addressed to the Box Issue Fee address above on the date indicated below.

Kevin L. Russell (Depositor's name)  
*[Signature]* (Signature)  
July 30, 2002 (Date)

APPLICATION NO.	FILING DATE	FIRST NAMED INVENTOR	ATTORNEY DOCKET NO.	CONFIRMATION NO.
09/550,476	04/14/2000	Bruce W. DeKock	BWD-7118.004	8794

TITLE OF INVENTION: SYSTEM FOR PROVIDING TRAFFIC INFORMATION

TOTAL CLAIMS	APPLN. TYPE	SMALL ENTITY	ISSUE FEE	PUBLICATION FEE	TOTAL FEE(S) DUE	DATE DUE
34	nonprovisional	YES	\$640	\$0	\$640	05/20/2002

EXAMINER	ART UNIT	CLASS-SUBCLASS
MARC COLEMAN, MARTHE Y	3661	701-117000

1. Change of correspondence address or indication of "Fee Address" (37 CFR 1.363). Use of PTO form(s) and Customer Number are recommended, but not required.  
 Change of correspondence address (or Change of Correspondence Address form PTO/SB/122) attached.  
 "Fee Address" indication (or "Fee Address" Indication form PTO/SB/47) attached.

2. For printing on the patent front page, list (1) the names of up to 3 registered patent attorneys or agents OR, alternatively, (2) the name of a single firm (having as a member a registered attorney or agent) and the names of up to 2 registered patent attorneys or agents. If no name is listed, no name will be printed.

Chernoff Vilhauer McClung & Stenzel, LLP  
2 \_\_\_\_\_  
3 \_\_\_\_\_

3. ASSIGNEE NAME AND RESIDENCE DATA TO BE PRINTED ON THE PATENT (print or type)  
PLEASE NOTE: Unless an assignee is identified below, no assignee data will appear on the patent. Inclusion of assignee data is only appropriate when an assignment has been previously submitted to the USPTO or is being submitted under separate cover. Completion of this form is NOT a substitute for filing an assignment.

(A) NAME OF ASSIGNEE: Bruce DeKock  
(B) RESIDENCE: (CITY and STATE OR COUNTRY): Bend, Oregon

Please check the appropriate assignee category or categories (will not be printed on the patent)  individual  corporation or other private group entity  government

4a. The following fee(s) are enclosed:  
 Issue Fee  
 Publication Fee  
 Advance Order - # of Copies \_\_\_\_\_

4b. Payment of Fee(s):  
 A check in the amount of the fee(s) is enclosed.  
 Payment by credit card. Form PTO-2038 is attached.  
 The Commissioner is hereby authorized by charge the required fee(s), or credit any overpayment, to Deposit Account Number 03-1550 (enclose an extra copy of this form).

The COMMISSIONER OF PATENTS AND TRADEMARKS is requested to apply the Issue Fee and Publication Fee (if any) or to re-apply any previously paid issue fee to the application identified above.

(Authorized Signature) *[Signature]* (Date) 07/30/02

NOTE: The Issue Fee and Publication Fee (if required) will not be accepted from anyone other than the applicant; a registered attorney or agent; or the assignee or other party in interest as shown by the records of the United States Patent and Trademark Office.

Burden Hour Statement: This form is estimated to take 0.2 hours to complete. Time will vary depending on the needs of the individual case. Any comments on the amount of time required to complete this form should be sent to the Chief Information Officer, United States Patent and Trademark Office, Washington, D.C. 20231. DO NOT SEND FEES OR COMPLETED FORMS TO THIS ADDRESS. SEND FEES AND THIS FORM TO: Box Issue Fee, Assistant Commissioner for Patents, Washington, D.C. 20231

Under the Paperwork Reduction Act of 1995, no persons are required to respond to a collection of information unless it displays a valid OMB control number.

RECEIVED  
AUG 07 2002  
OFFICE OF PETITIONS

IN THE UNITED STATES PATENT AND TRADEMARK OFFICE

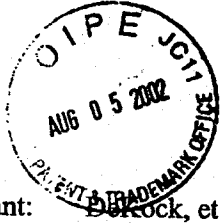

PATENT EXAMINING OPERATIONS

PATENT APPLICATION

Applicant: ~~D~~Rock, et al.

Group Art Unit: 3661

Serial No.: 09/550,476

Examiner: Coleman

Filed: April 14, 2000

Title: SYSTEM FOR PROVIDING TRAFFIC INFORMATION

LETTER TO THE OFFICIAL DRAFTSMAN

1600 ODS Tower  
601 S W Second Avenue  
Portland, Oregon 97204

July 30, 2002

Official Draftsman  
Commissioner for Patents  
Washington, D.C. 20231

Dear Sir:

Enclosed are FOURTEEN (14) sheets of formal drawings to replace the original drawings filed with above identified patent application. We have received the Notice of Draftsperson's Review requesting changes.

Please charge any fees due to Deposit Account 03-1550.

Respectfully submitted,

  
Kevin L. Russell  
Attorney for Applicant  
Tel: (503) 227-5631

RECEIVED

AUG 07 2002

OFFICE OF PETITIONS

Exhibit E  
Page 271 of 311

COPY OF PAPERS  
ORIGINALLY FILED

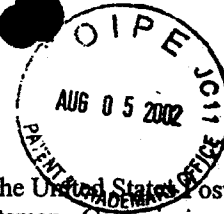

CERTIFICATE OF MAILING

I hereby certify that this correspondence is being deposited with the United States Postal Service as first class mail in an envelope addressed to: Letter to the Official Draftsman, Commissioner for Patents, Washington, D.C. 20231.

Dated: July 30, 2002

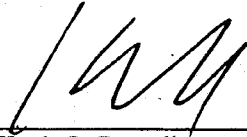
  
\_\_\_\_\_  
Kevin L. Russell

RECEIVED  
AUG 07 2002  
OFFICE OF PETITIONS  
Exhibit E  
Page 272 of 311

#14

<b>TRANSMITTAL FORM</b> <small>(to be used for all correspondence after initial filing)</small>	<b>Application Number</b>	09/950,476
	<b>Filing Date</b>	April 14, 2000
	<b>First Named Inventor</b>	DeKock, et al.
	<b>Group Art Unit</b>	3661
	<b>Examiner Name</b>	Coleman
<b>Total Number of Pages in this Submission</b>	17	<b>Attorney Docket Number</b> 7116.004

ENCLOSURES (check all that apply)		
<input type="checkbox"/> Fee transmittal <input type="checkbox"/> Fee attached form <input type="checkbox"/> Amendment <input type="checkbox"/> After Final/ Response <input type="checkbox"/> Affidavits/Declaration(s) <input type="checkbox"/> Extension of Time Request <input type="checkbox"/> Express Abandonment Request <input type="checkbox"/> Information Disclosure Statement <input type="checkbox"/> Certified copy of Priority Documents <input type="checkbox"/> Response to Missing Parts/ Incomplete Application <input type="checkbox"/> Response to Missing Parts Under 37 CFR 1.52 or 1.53	<input type="checkbox"/> Assignment Papers (for an application) <input checked="" type="checkbox"/> Drawing(s) <input type="checkbox"/> Licensing Related Papers <input type="checkbox"/> Petition Routing Slip (PTO/SB/69) and Accompanying Petition <input type="checkbox"/> Petition to Convert to a Provisional Application <input type="checkbox"/> Power of Attorney, Revocation, Change of Correspondence Address <input type="checkbox"/> Terminal Disclaimer <input type="checkbox"/> Small Entity Statement <input type="checkbox"/> Request for Refund	<input type="checkbox"/> After Allowance Communication to Group <input type="checkbox"/> Appeal Communication to Board of Appeals and Interferences <input type="checkbox"/> Appeal Communication to Group (Appeal Notice, Brief, Reply Brief) <input type="checkbox"/> Proprietary Information <input type="checkbox"/> Status Letter <input checked="" type="checkbox"/> Additional Enclosures (identify below) Confirmation postcard
Remarks:		

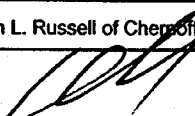
SIGNATURE OF APPLICANT, ATTORNEY OR AGENT	
<b>Firm or Individual Name</b>	Kevin L. Russell of Chernoff, Vilhauer, McClung & Stenzel, LLP
<b>Signature</b>	
<b>Date</b>	July 30, 2002

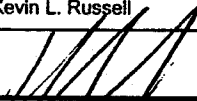
CERTIFICATE OF MAILING	
I hereby certify that, on the date shown below, this correspondence is being deposited with the United States Postal Service in an envelope addressed to: Official Draftsperson, Commissioner for Patents, Washington, D.C., 20231 <input checked="" type="checkbox"/> with sufficient postage as first class mail <input type="checkbox"/> as "Express Mail Post Office to Addressee" - mailing label no. _____	
<b>Type or print name</b>	Kevin L. Russell
<b>Signature</b>	
<b>Date</b>	July 30, 2002

RECEIVED  
AUG 07 2002  
OFFICE OF PETITIONS

AUG 05 2002

6466862

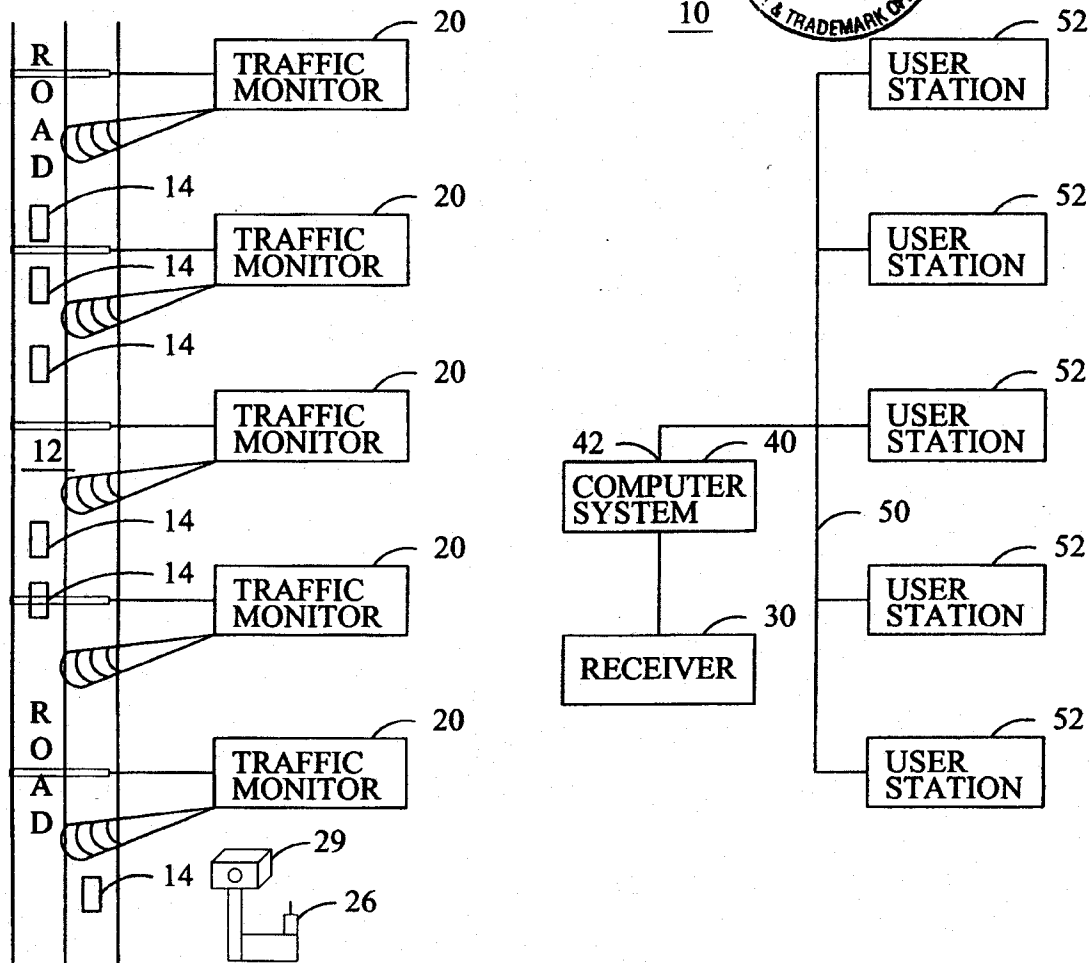

FIG. 1

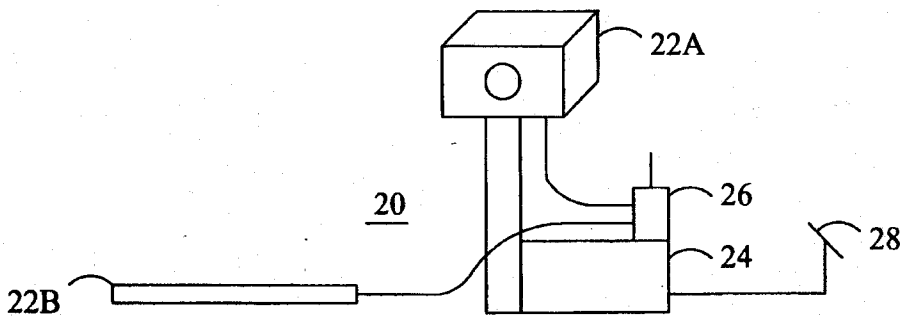

FIG. 2

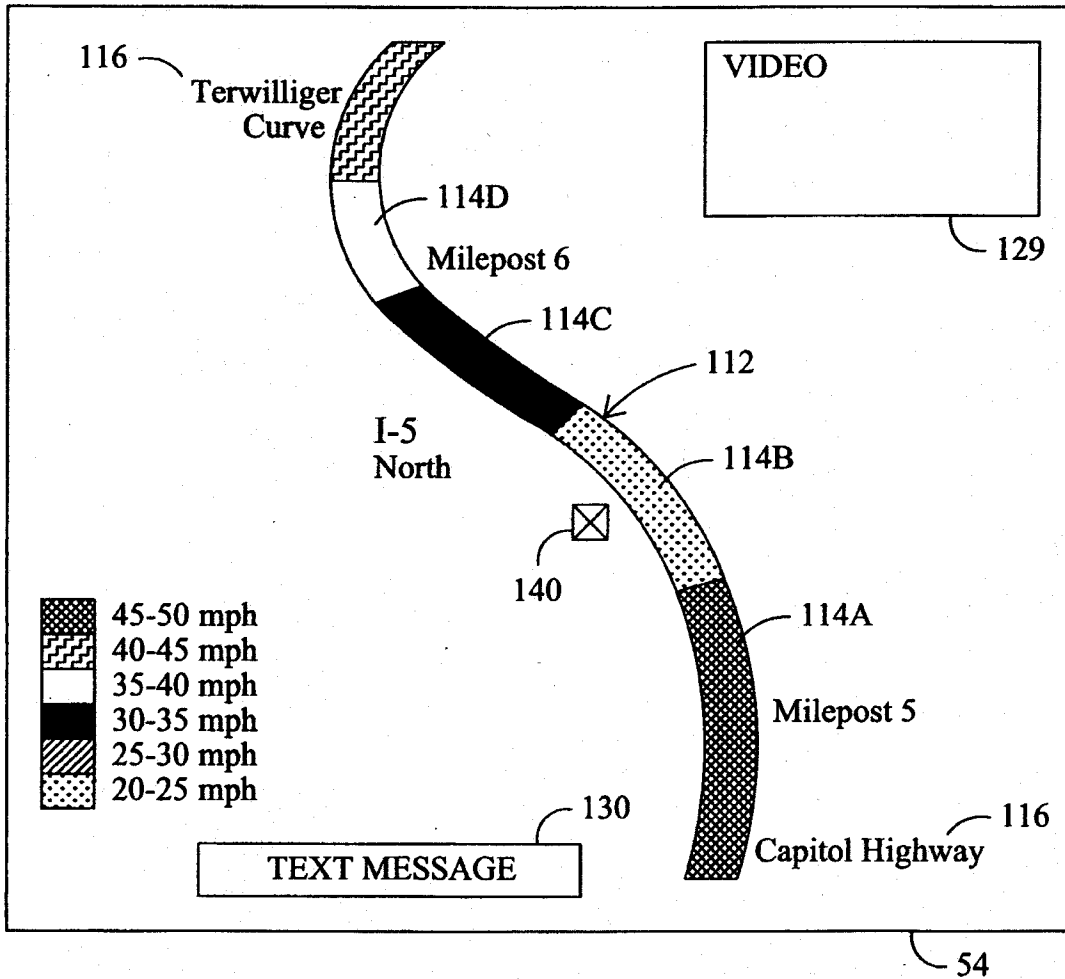
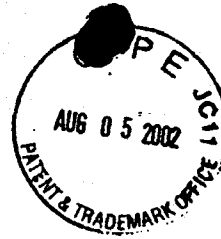

FIG. 3

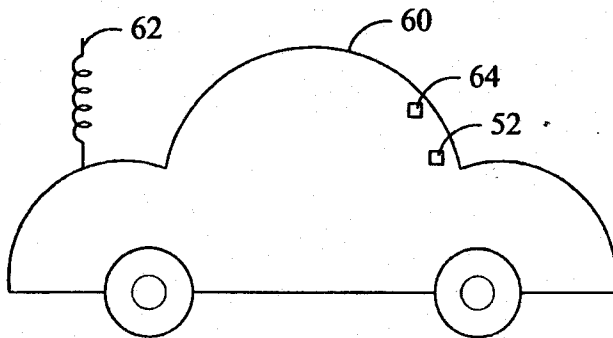
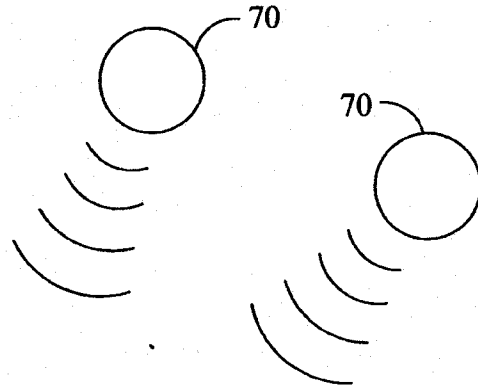

FIG. 4



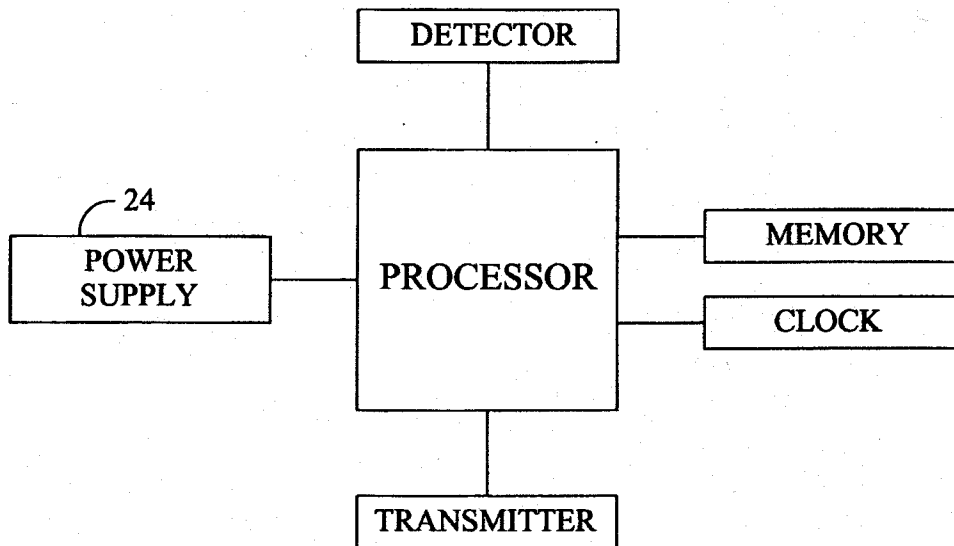

FIG. 5

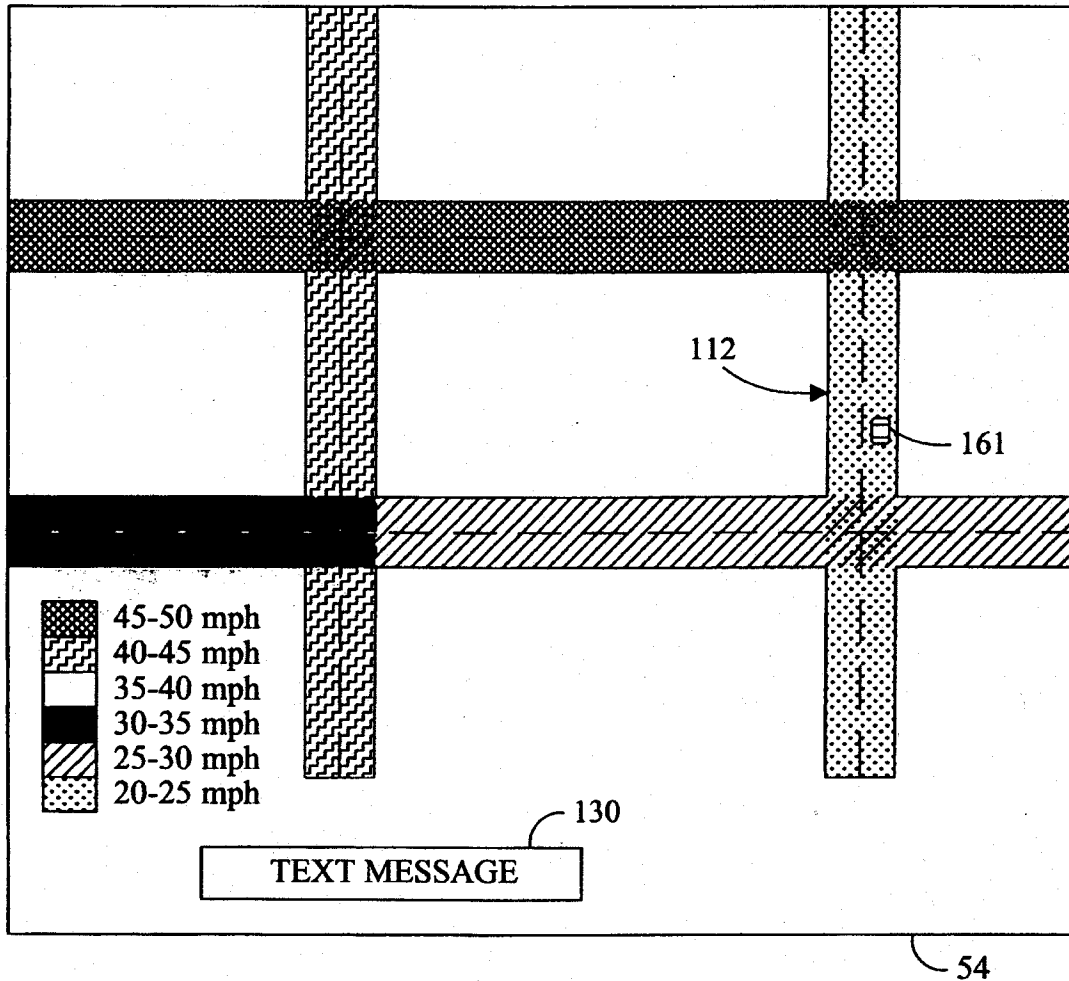

FIG. 6

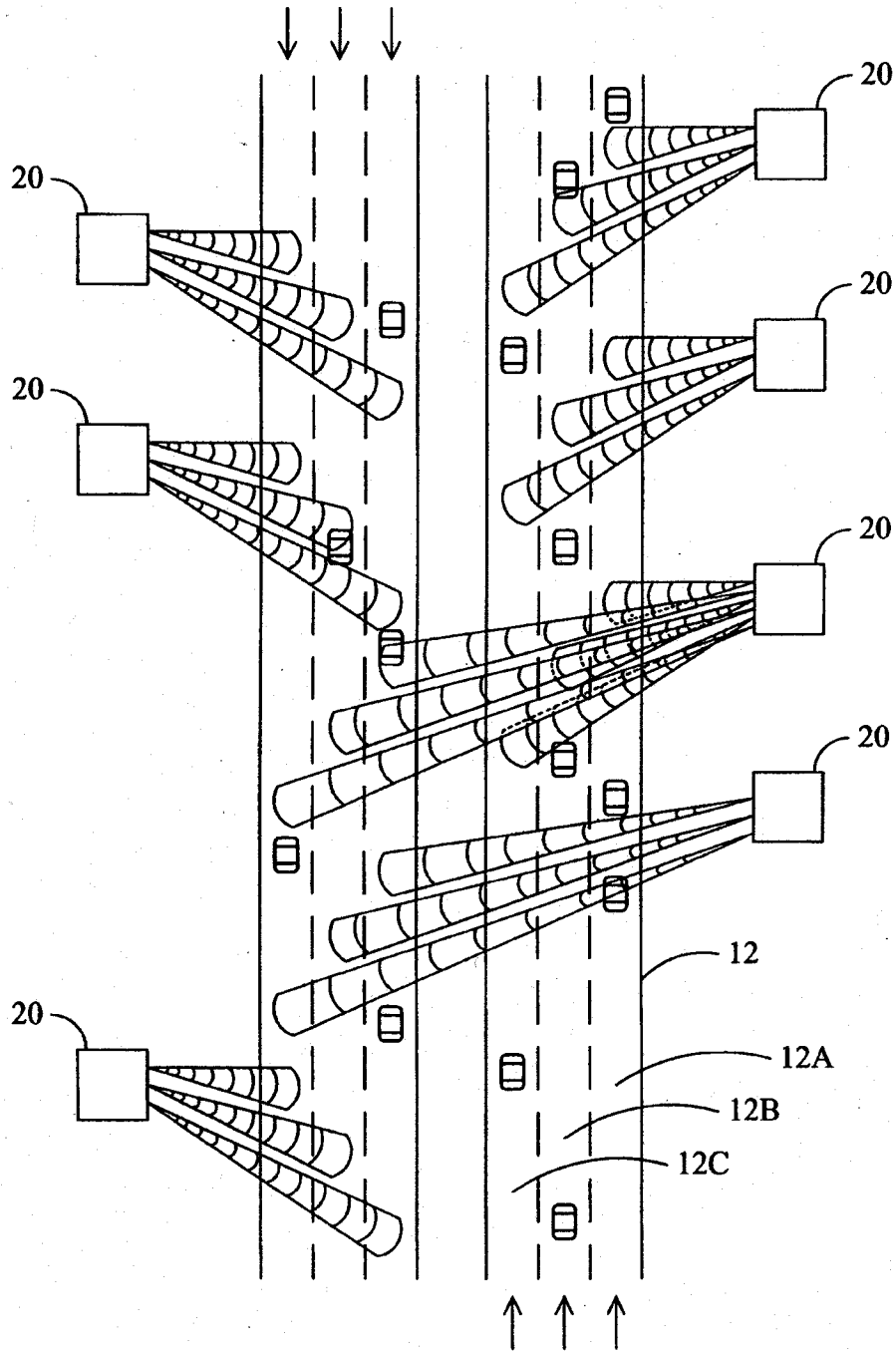

FIG. 7



54

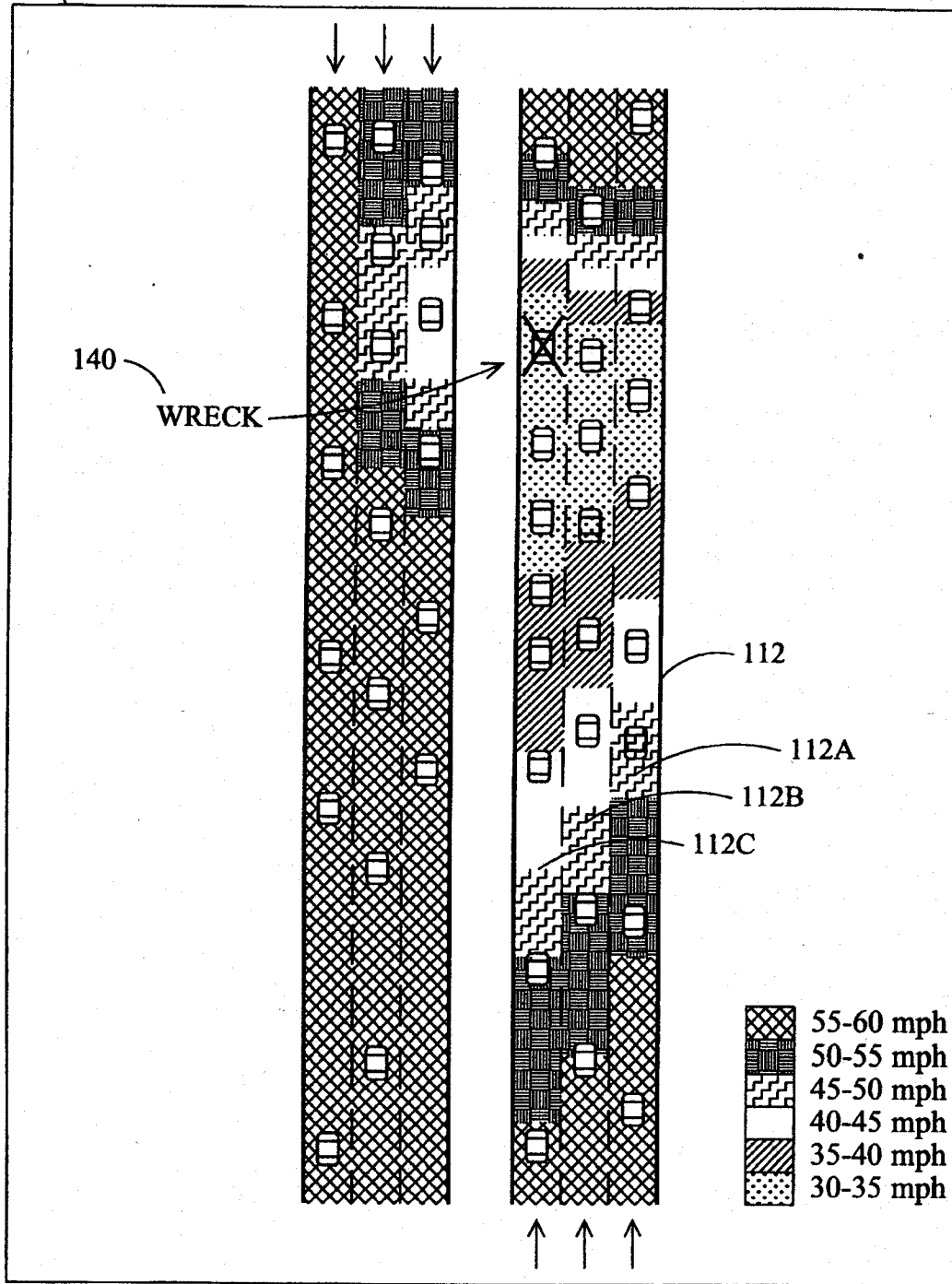

FIG. 8

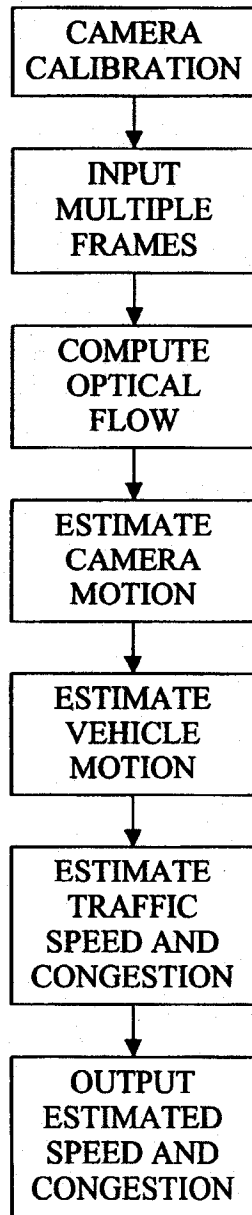

FIG. 9

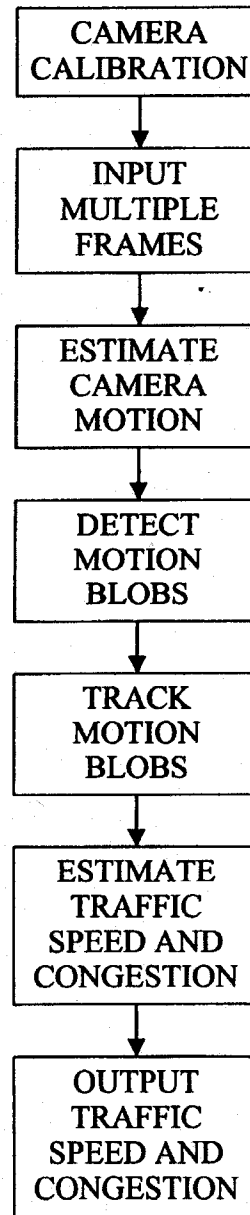

FIG. 10

RECEIVED

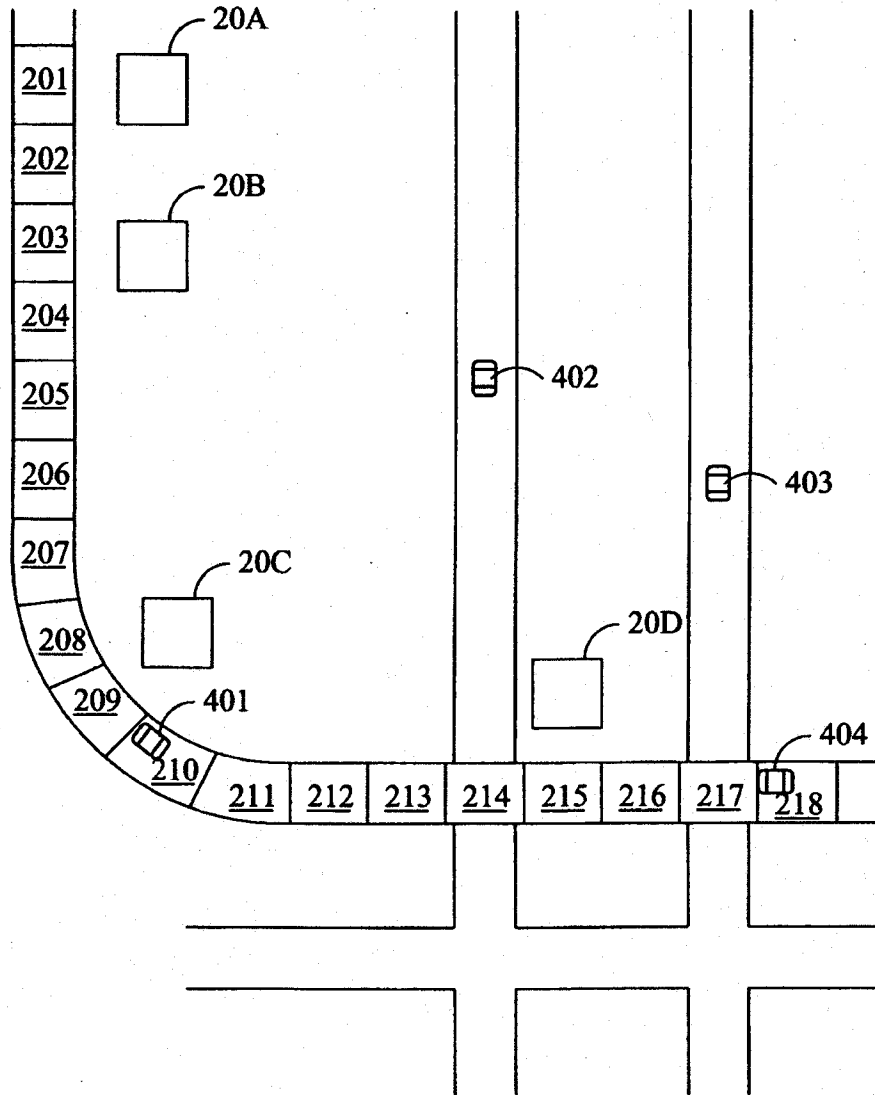

FIG. 11

COPY OF PAPERS  
ORIGINALLY FILED



LOCATION	LAT/LONG	ROAD	DIRECTION	VELOCITY
201	45°54'36"N/ 37°32'12"E	INTERSTATE	0°	55 MPH
202	⋮	LOCAL	27°	20 MPH
203		BYPASS	EAST	STOPPED
204		RESIDENTIAL	NW	⋮
205		⋮	⋮	
206				
207				
⋮				

FIG. 12



54

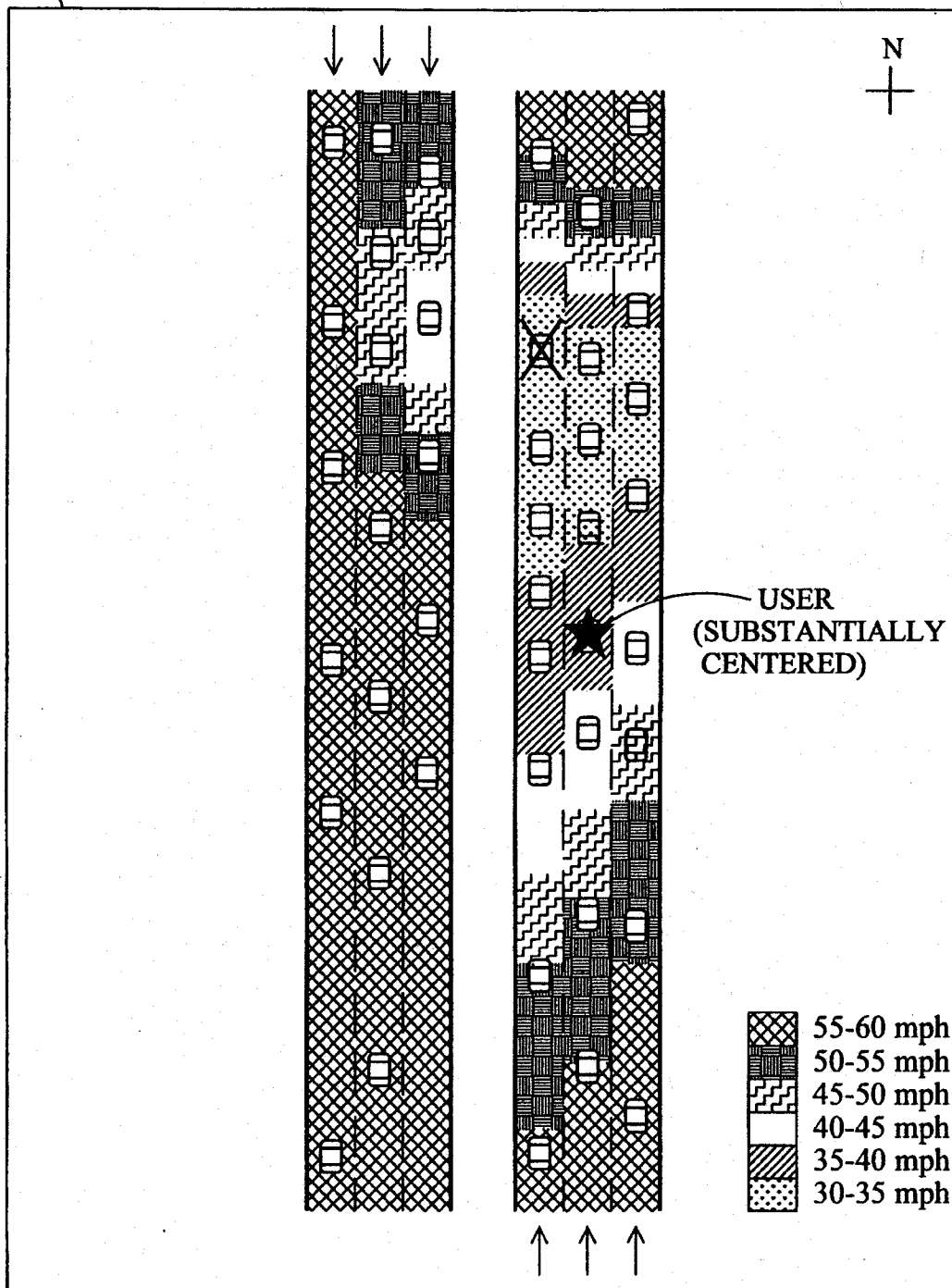

FIG. 13





54

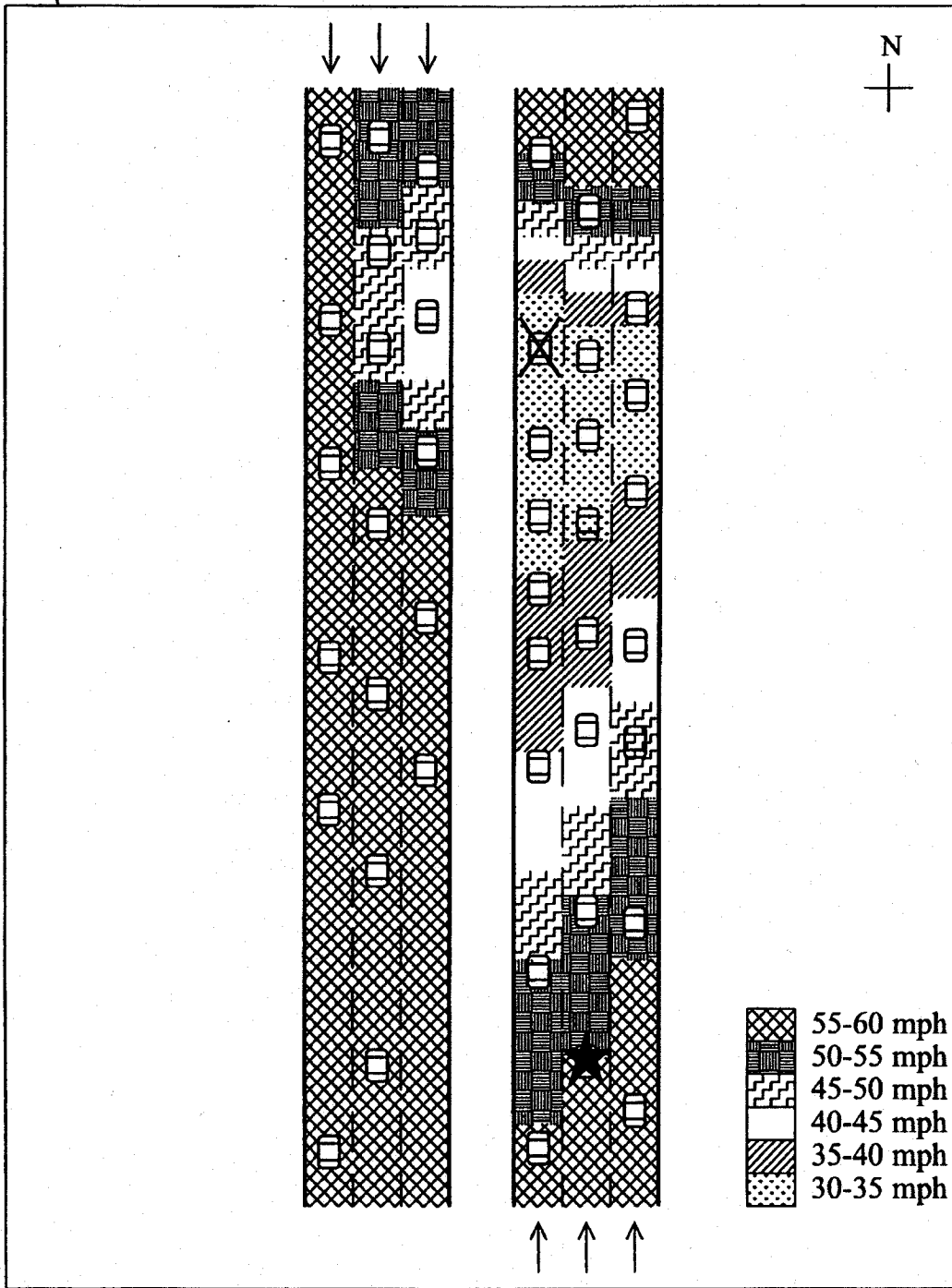

FIG. 14



54

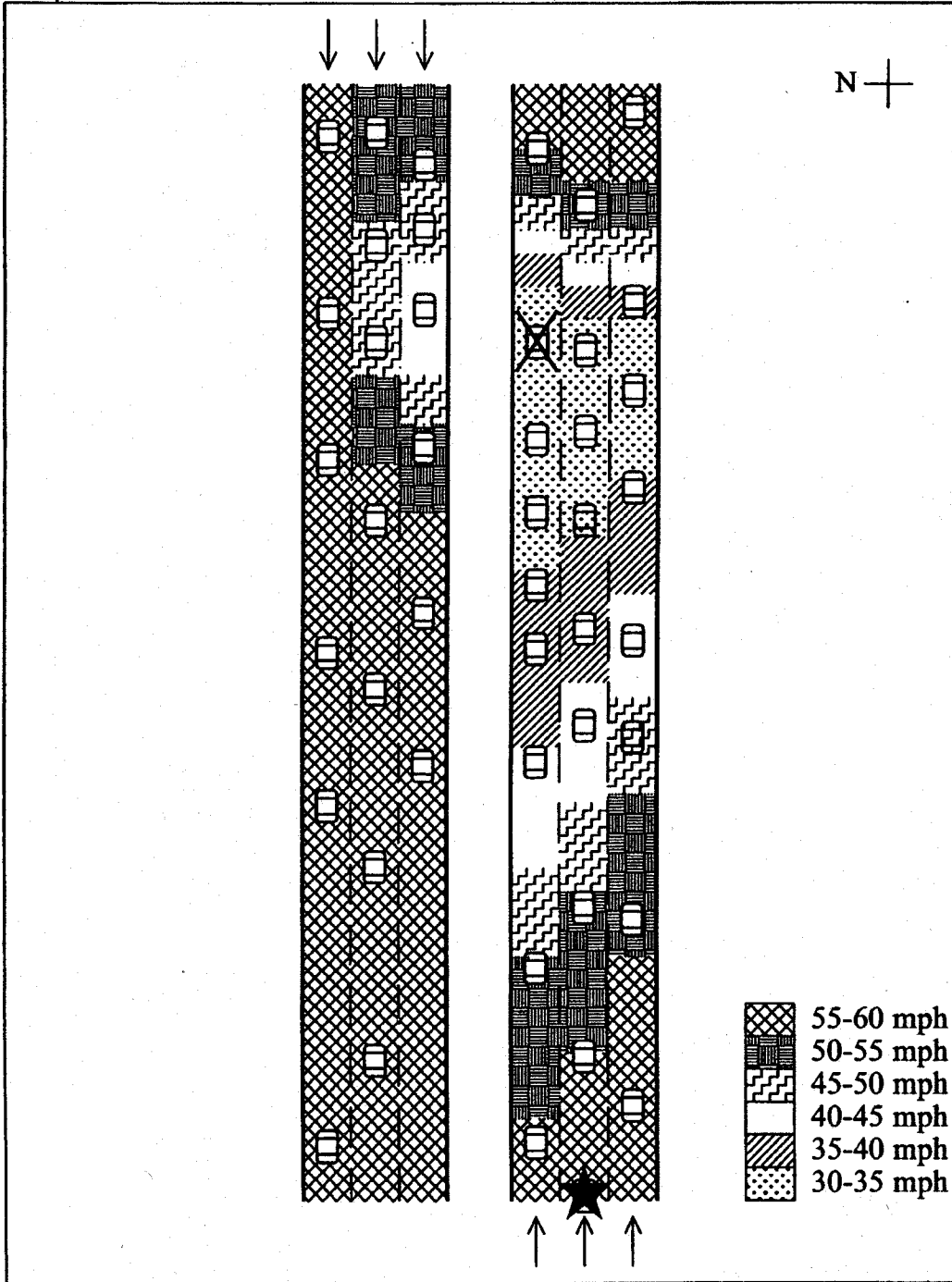

FIG. 15

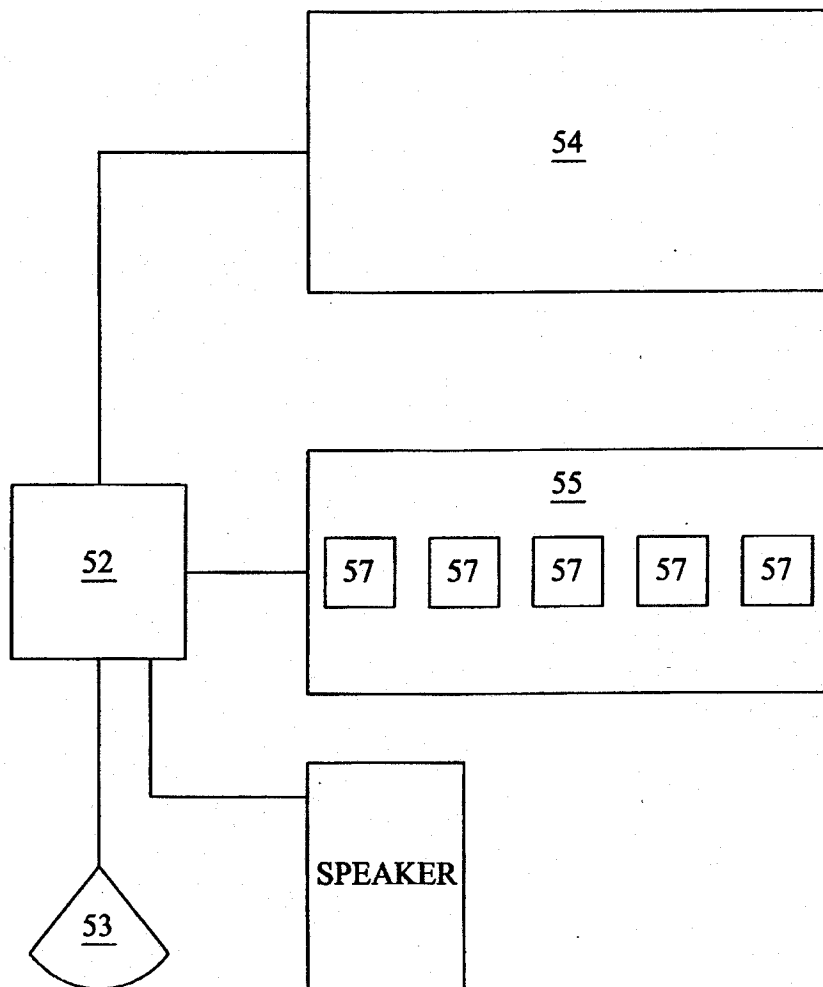
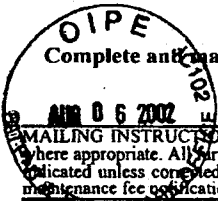

FIG. 16





PART B - FEE(S) TRANSMITTAL

84 B \$

Complete and mail this form, together with applicable fee(s), to:

Box ISSUE FEE
Assistant Commissioner for Patents
Washington, D.C. 20231

MAILING INSTRUCTIONS: This form should be used for transmitting the ISSUE FEE and PUBLICATION FEE (if required). Blocks 1 through 4 should be completed where appropriate. All further correspondence including the Patent, advance orders and notification of maintenance fees will be mailed to the current correspondence address as indicated unless corrected below or directed otherwise in Block 1, by (a) specifying a new correspondence address; and/or (b) indicating a separate "FEE ADDRESS" for maintenance fee notifications.

CUSTOMER CORRESPONDENCE ADDRESS (Note: Legibly mark-up with any corrections or use Block 1)

7590 02/20/2002

Bruce W DeKock
1600 ODS Tower
801 S W Second Avenue
Portland, OR 97204

Note: The certificate of mailing below can only be used for domestic mailings of the Fee(s) Transmittal. This certificate cannot be used for any other accompanying papers. Each additional paper, such as an assignment or formal drawing, must have its own certificate of mailing.

Certificate of Mailing

I hereby certify that this Fee(s) Transmittal is being deposited with the United States Postal Service with sufficient postage for first class mail in an envelope addressed to the Box Issue Fee address above on the date indicated below.

Kevin L. Russell (Depositor's name)
[Signature] (Signature)
July 30, 2002 (Date)

Table with 5 columns: APPLICATION NO., FILING DATE, FIRST NAMED INVENTOR, ATTORNEY DOCKET NO., CONFIRMATION NO. Values: 09/550,476, 04/14/2000, Bruce W. DeKock, BWD-7118.004, 8794

TITLE OF INVENTION: SYSTEM FOR PROVIDING TRAFFIC INFORMATION

Table with 7 columns: TOTAL CLAIMS, APPLN. TYPE, SMALL ENTITY, ISSUE FEE, PUBLICATION FEE, TOTAL FEE(S) DUE, DATE DUE. Values: 34, nonprovisional, YES, \$640, \$0, \$640, 05/20/2002

Table with 3 columns: EXAMINER, ART UNIT, CLASS-SUBCLASS. Values: MARC COLEMAN, MARTHE Y, 3661, 701-117000

- 1. Change of correspondence address or indication of "Fee Address" (37 CFR 1.363). Use of PTO form(s) and Customer Number are recommended, but not required.
Change of correspondence address (or Change of Correspondence Address form PTO/SB/122) attached.
"Fee Address" indication (or "Fee Address" Indication form PTO/SB/47) attached.

- 2. For printing on the patent front page, list (1) the names of up to 3 registered patent attorneys or agents OR, alternatively, (2) the name of a single firm (having as a member a registered attorney or agent) and the names of up to 2 registered patent attorneys or agents. If no name is listed, no name will be printed.

Chernoff Vilhauer McClung & Stenzel, LLP

3. ASSIGNEE NAME AND RESIDENCE DATA TO BE PRINTED ON THE PATENT (print or type)

PLEASE NOTE: Unless an assignee is identified below, no assignee data will appear on the patent. Inclusion of assignee data is only appropriate when an assignment has been previously submitted to the USPTO or is being submitted under separate cover. Completion of this form is NOT a substitute for filing an assignment.

(A) NAME OF ASSIGNEE

(B) RESIDENCE: (CITY and STATE OR COUNTRY)

Bruce DeKock

Bend, Oregon

Please check the appropriate assignee category or categories (will not be printed on the patent) [X] individual [ ] corporation or other private group entity [ ] government

4a. The following fee(s) are enclosed:

- [X] Issue Fee
[ ] Publication Fee
[X] Advance Order - # of Copies

4b. Payment of Fee(s):

- [X] A check in the amount of the fee(s) is enclosed.
[ ] Payment by credit card. Form PTO-2038 is attached.
[X] The Commissioner is hereby authorized by charge the required fee(s), or credit any overpayment, to Deposit Account Number 03-1550 (enclose an extra copy of this form).

The COMMISSIONER OF PATENTS AND TRADEMARKS is requested to apply the Issue Fee and Publication Fee (if any) or to re-apply any previously paid issue fee to the application identified above.

(Authorized Signature) [Signature] (Date) 07/30/02

NOTE: The Issue Fee and Publication Fee (if required) will not be accepted from anyone other than the applicant; a registered attorney or agent; or the assignee or other party in interest as shown by the records of the United States Patent and Trademark Office.

Burden Hour Statement: This form is estimated to take 0.2 hours to complete. Time will vary depending on the needs of the individual case. Any comments on the amount of time required to complete this form should be sent to the Chief Information Officer, United States Patent and Trademark Office, Washington, D.C. 20231. DO NOT SEND FEES OR COMPLETED FORMS TO THIS ADDRESS. SEND FEES AND THIS FORM TO: Box Issue Fee, Assistant Commissioner for Patents, Washington, D.C. 20231

Under the Paperwork Reduction Act of 1995, no persons are required to respond to a collection of information unless it displays a valid OMB control number.

08/08/2002 MBIZIME2 00000108 09550476

01 FC:242
02 FC:561

640.00 DP
9.00 DP

TRANSMIT THIS FORM WITH FEE(S)

AUG 06 2002  
 PATENT & TRADEMARK OFFICE

2001

<b>TRANSMITTAL FORM</b> (to be used for all correspondence after initial filing)	Application Number	09/550,476	COPY OF PAPERS ORIGINALLY FILED
	Filing Date	April 14, 2000	
	First Named Inventor	DeKock, et al.	
	Group Art Unit	3661	
	Examiner Name	Coleman	
Total Number of Pages in this Submission	17	Attorney Docket Number	7116.004

ENCLOSURES (check all that apply)		
<input type="checkbox"/> Fee transmittal <input type="checkbox"/> Fee attached form <input type="checkbox"/> Amendment <input type="checkbox"/> After Final/ Response <input type="checkbox"/> Affidavits/Declaration(s) <input type="checkbox"/> Extension of Time Request <input type="checkbox"/> Express Abandonment Request <input type="checkbox"/> Information Disclosure Statement <input type="checkbox"/> Certified copy of Priority Documents <input type="checkbox"/> Response to Missing Parts/ Incomplete Application <input type="checkbox"/> Response to Missing Parts Under 37 CFR 1.52 or 1.53	<input type="checkbox"/> Assignment Papers (for an application) <input checked="" type="checkbox"/> Drawing(s) <input type="checkbox"/> Licensing Related Papers <input type="checkbox"/> Petition Routing Slip (PTO/SB/69) and Accompanying Petition <input type="checkbox"/> Petition to Convert to a Provisional Application <input type="checkbox"/> Power of Attorney, Revocation, Change of Correspondence Address <input type="checkbox"/> Terminal Disclaimer <input type="checkbox"/> Small Entity Statement <input type="checkbox"/> Request for Refund Remarks:	<input type="checkbox"/> After Allowance Communication to Group <input type="checkbox"/> Appeal Communication to Board of Appeals and Interferences <input type="checkbox"/> Appeal Communication to Group (Appeal Notice, Brief, Reply Brief) <input type="checkbox"/> Proprietary Information <input type="checkbox"/> Status Letter <input checked="" type="checkbox"/> Additional Enclosures (identify below) Confirmation postcard

GROUP 3600

AUG 09 2002

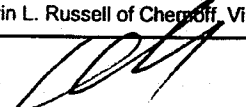
SIGNATURE OF APPLICANT, ATTORNEY OR AGENT	
Firm or Individual Name	Kevin L. Russell of Chernoff, Vilhauer, McClung & Stenzel, LLP
Signature	
Date	July 30, 2002

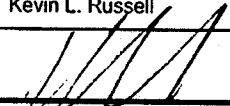
CERTIFICATE OF MAILING	
I hereby certify that, on the date shown below, this correspondence is being deposited with the United States Postal Service in an envelope addressed to: Official Draftsperson, Commissioner for Patents, Washington, D.C., 20231 <input checked="" type="checkbox"/> with sufficient postage as first class mail <input type="checkbox"/> as "Express Mail Post Office to Addressee" - mailing label no. _____	
Type or print name	Kevin L. Russell
Signature	
Date	July 30, 2002

RECEIVED

AUG 21 2002

OFFICE OF PETITIONS

Exhibit E  
 Page 290 of 311



IN THE UNITED STATES PATENT AND TRADEMARK OFFICE  
PATENT EXAMINING OPERATIONS  
PATENT APPLICATION

Applicant: DeKock, et al. Group Art Unit: 3661  
Serial No.: 09/550,476 Examiner: Coleman  
Filed: April 14, 2000  
Title: SYSTEM FOR PROVIDING TRAFFIC INFORMATION

LETTER TO THE OFFICIAL DRAFTSMAN

1600 ODS Tower  
601 S W Second Avenue  
Portland, Oregon 97204

July 30, 2002

Official Draftsman  
Commissioner for Patents  
Washington, D.C. 20231

Dear Sir:

Enclosed are FOURTEEN (14) sheets of formal drawings to replace the original drawings filed with above identified patent application. We have received the Notice of Draftsperson's Review requesting changes.

Please charge any fees due to Deposit Account 03-1550.

Respectfully submitted,

Kevin L. Russell  
Attorney for Applicant  
Tel: (503) 227-5631

RECEIVED  
AUG 0 9 2002  
GROUP 3600

RECEIVED  
AUG 2 1 2002  
OFFICE OF PETITIONS

AUG 06 2002  
PATENT & TRADEMARK OFFICE

COPY OF PAPERS  
ORIGINALLY FILED

CERTIFICATE OF MAILING

I hereby certify that this correspondence is being deposited with the United States Postal Service as first class mail in an envelope addressed to: Letter to the Official Draftsman, Commissioner for Patents, Washington, D.C. 20231.

Dated: July 30, 2002

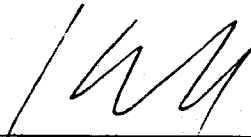
  
\_\_\_\_\_  
Kevin L. Russell

RECEIVED  
AUG 09 2002  
GROUP 3600

RECEIVED  
AUG 21 2002  
OFFICE OF PETITIONS



AUG 06 2002  
PATENT & TRADEMARK OFFICE

COPY OF PAPERS  
ORIGINALLY FILED

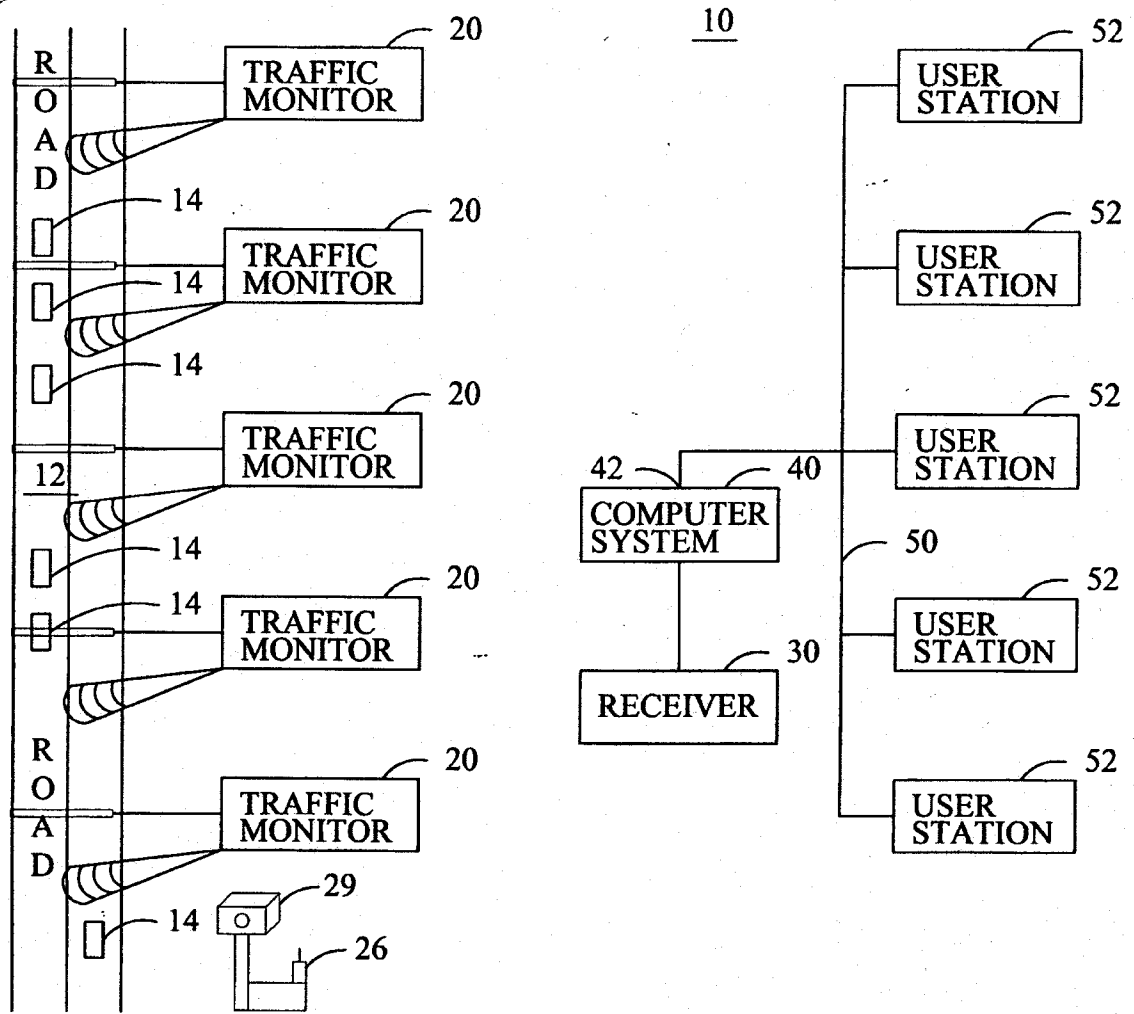

FIG. 1

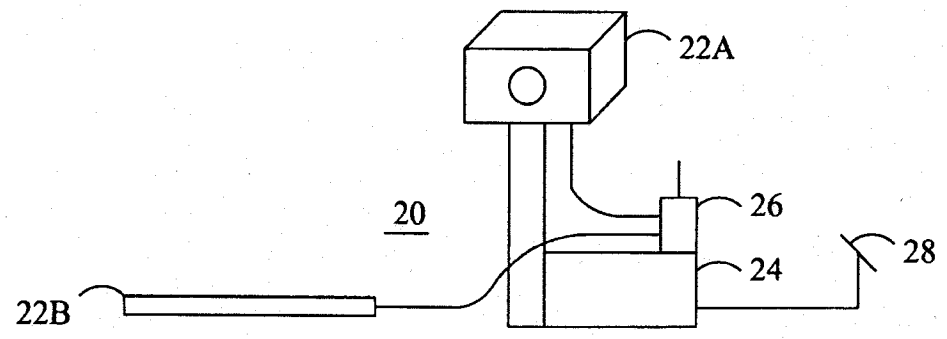

FIG. 2



COPY OF PAPERS  
ORIGINALLY FILED

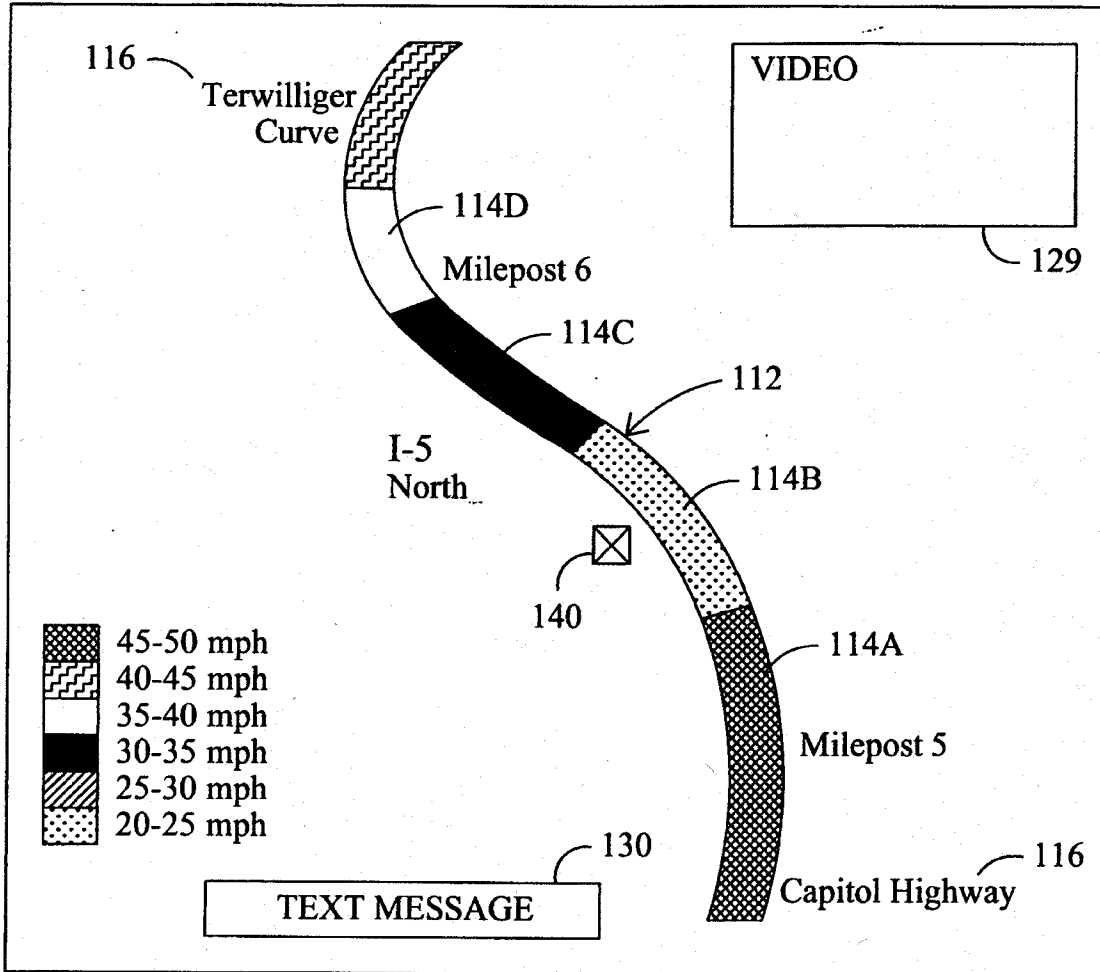

FIG. 3

of a road  
to a road  
to a road

JUL 14 2002  
AUG 06 2002  
PATENT & TRADEMARK OFFICE

COPY OF PAPER  
ORIGINALLY FILED

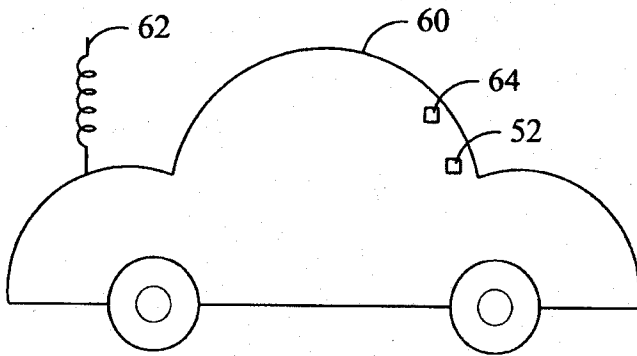
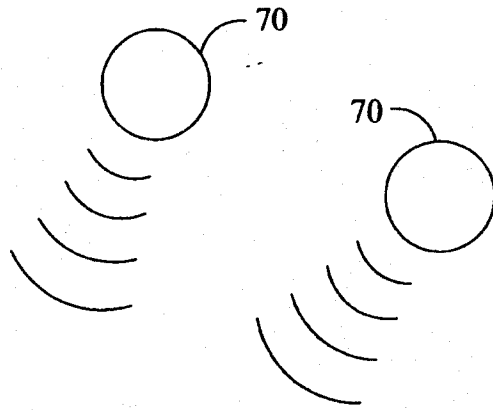

FIG. 4



COPY OF PAPERS  
ORIGINALLY FILED

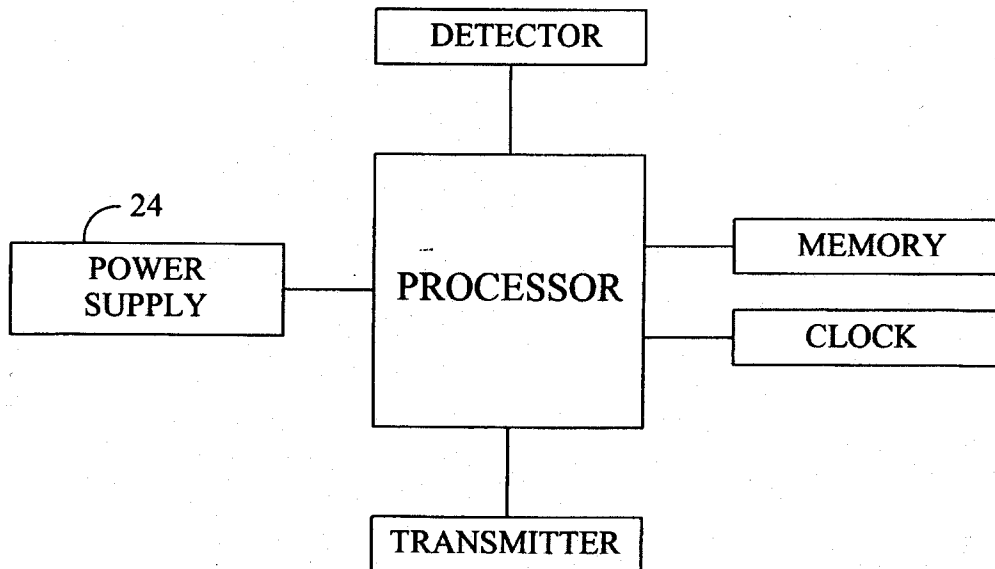

FIG. 5

2003  
1107e  
00000

AUG 06 2002  
PATENT & TRADEMARK OFFICE

COPY OF PAPERS  
ORIGINALLY FILED

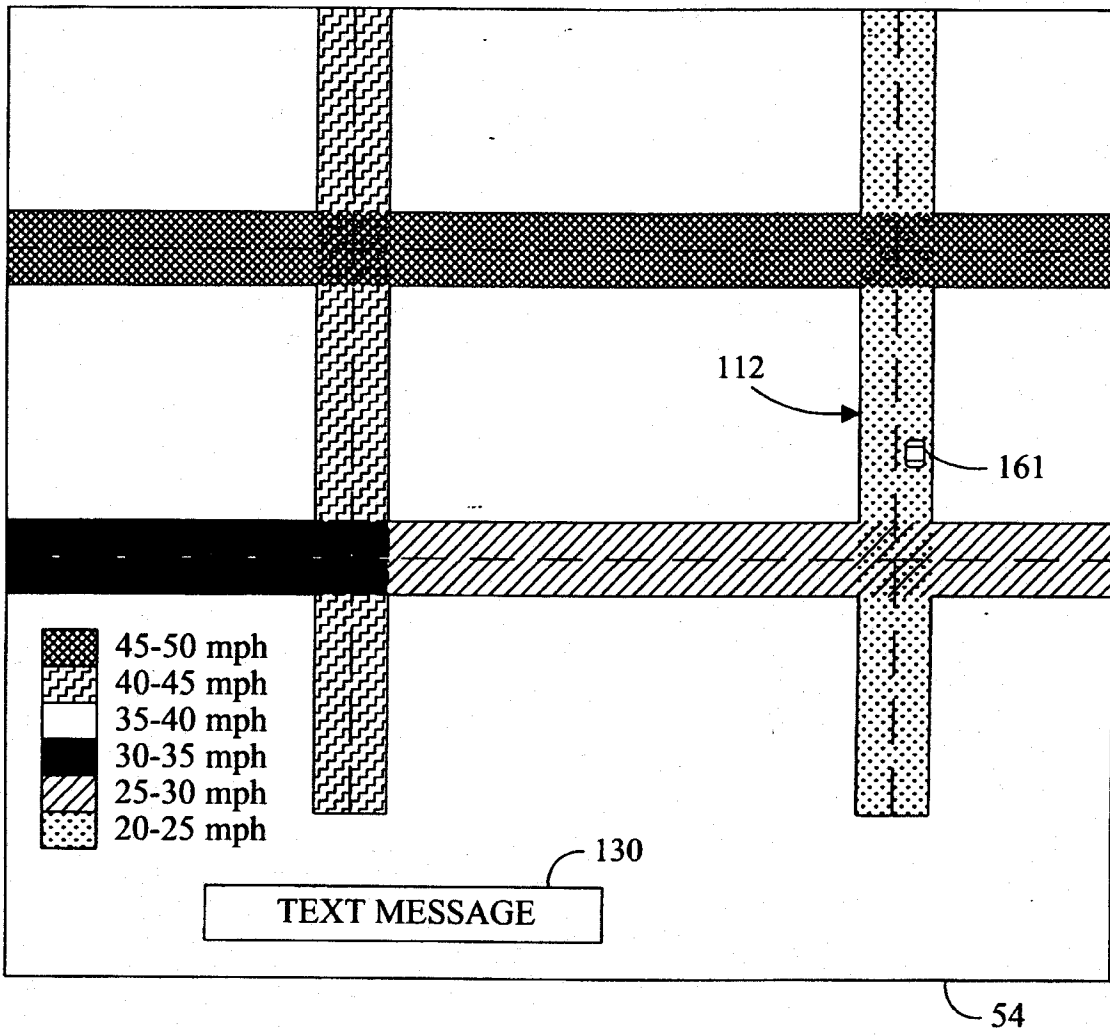

FIG. 6

O.I.P.F. JGIA  
AUG 06 2002  
PATENT & TRADEMARK OFFICE

CO. OF PAPERS  
ORIGINALLY FILED

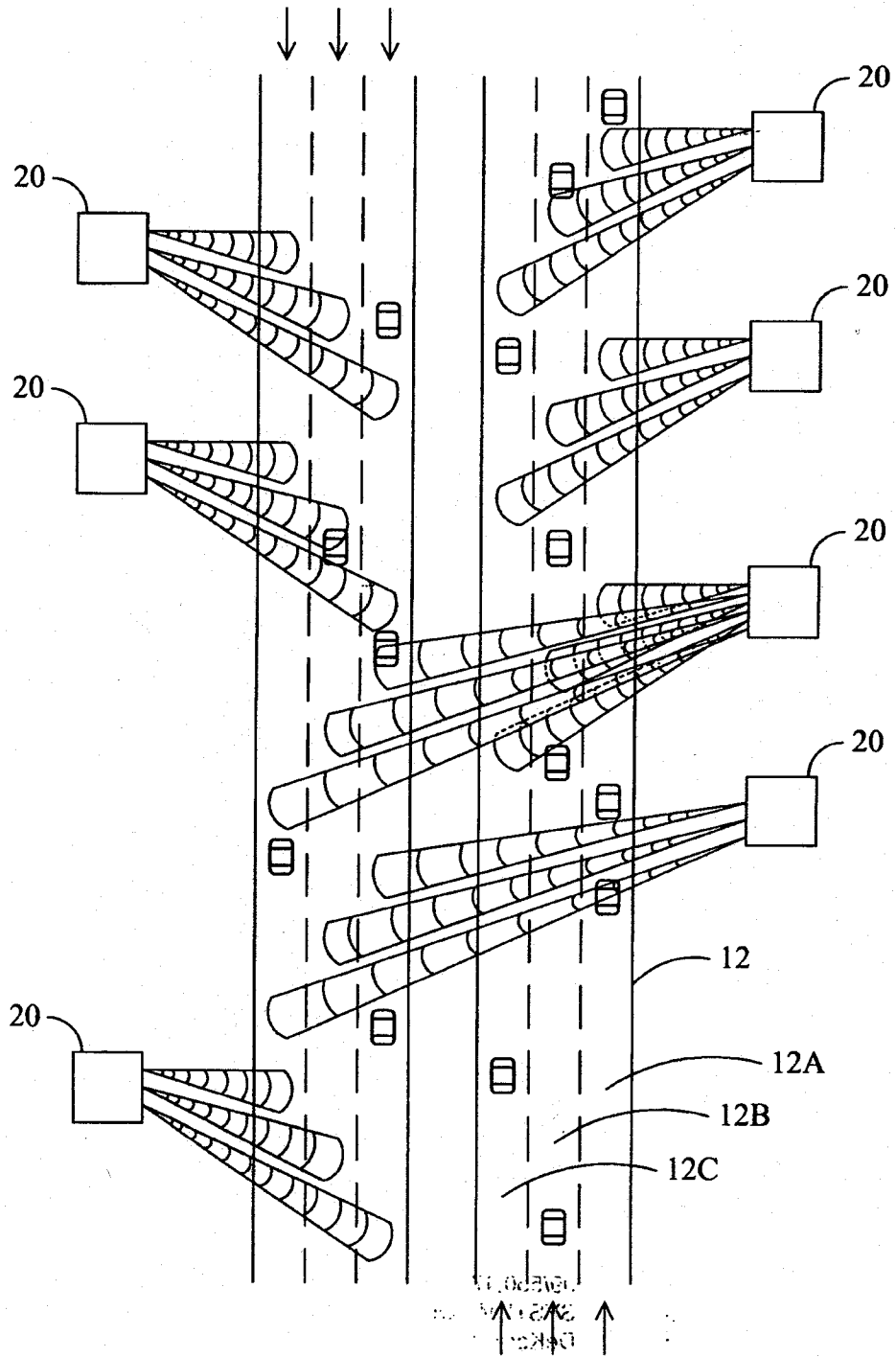

FIG. 7

54

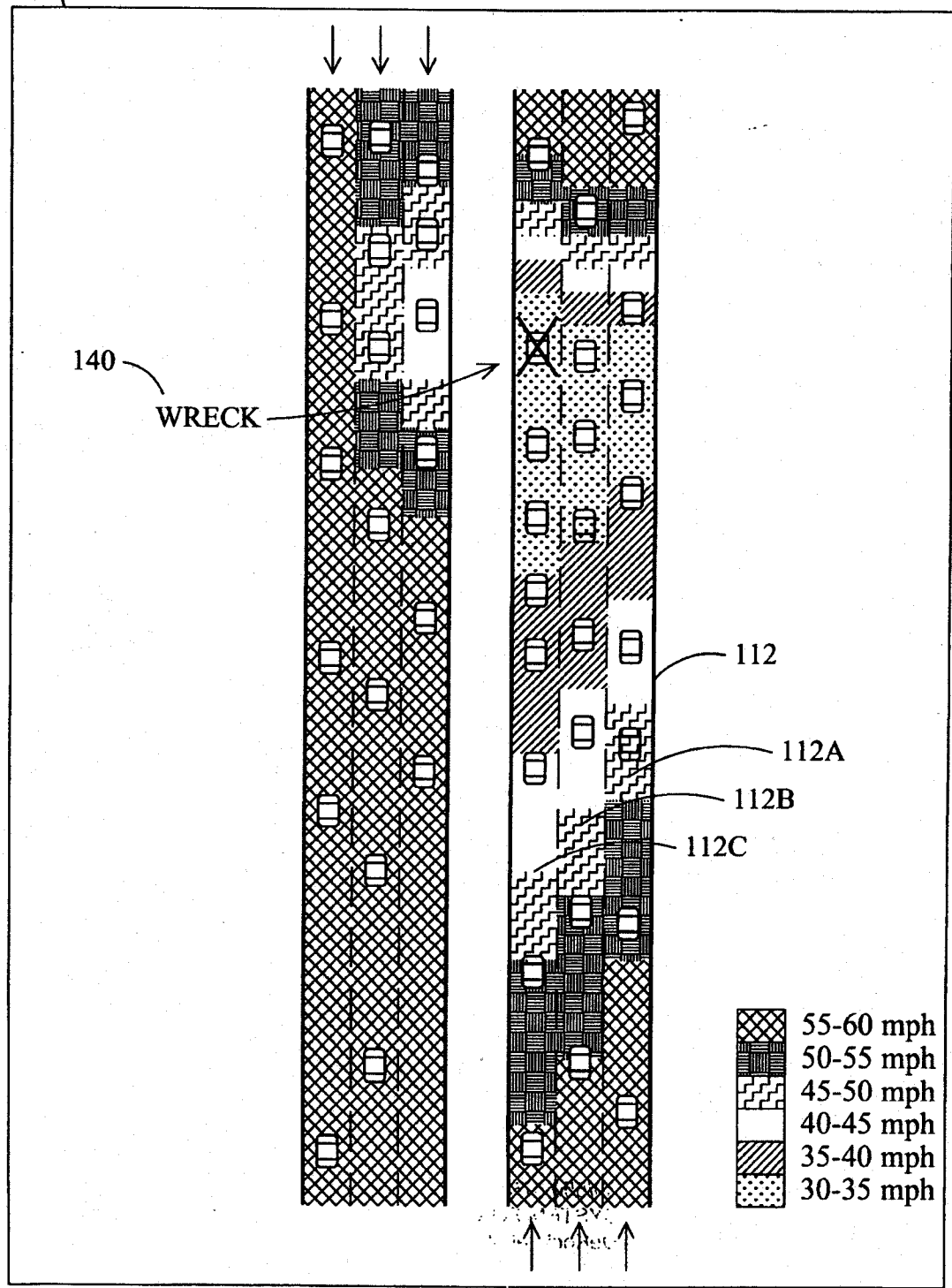

FIG. 8



COPIES OF PAPERS  
ORIGINALLY FILED

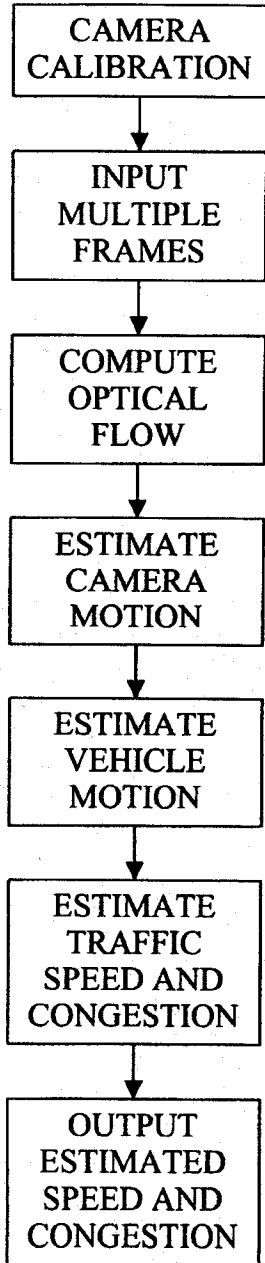

FIG. 9

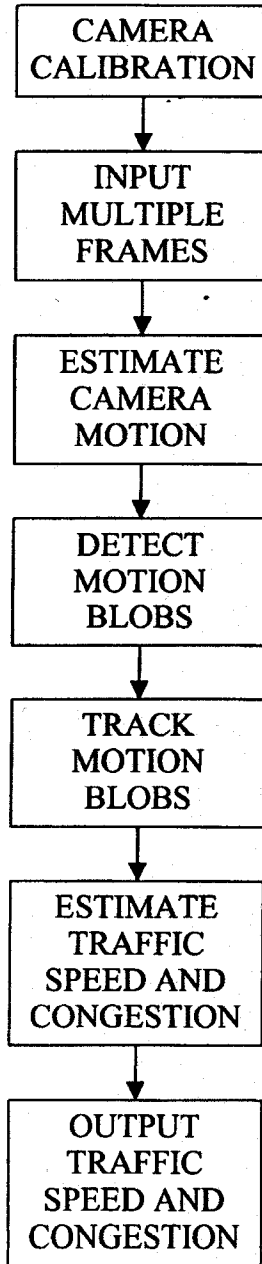

FIG. 10

RECEIVED  
AUG 09 2002  
GROUP 3600



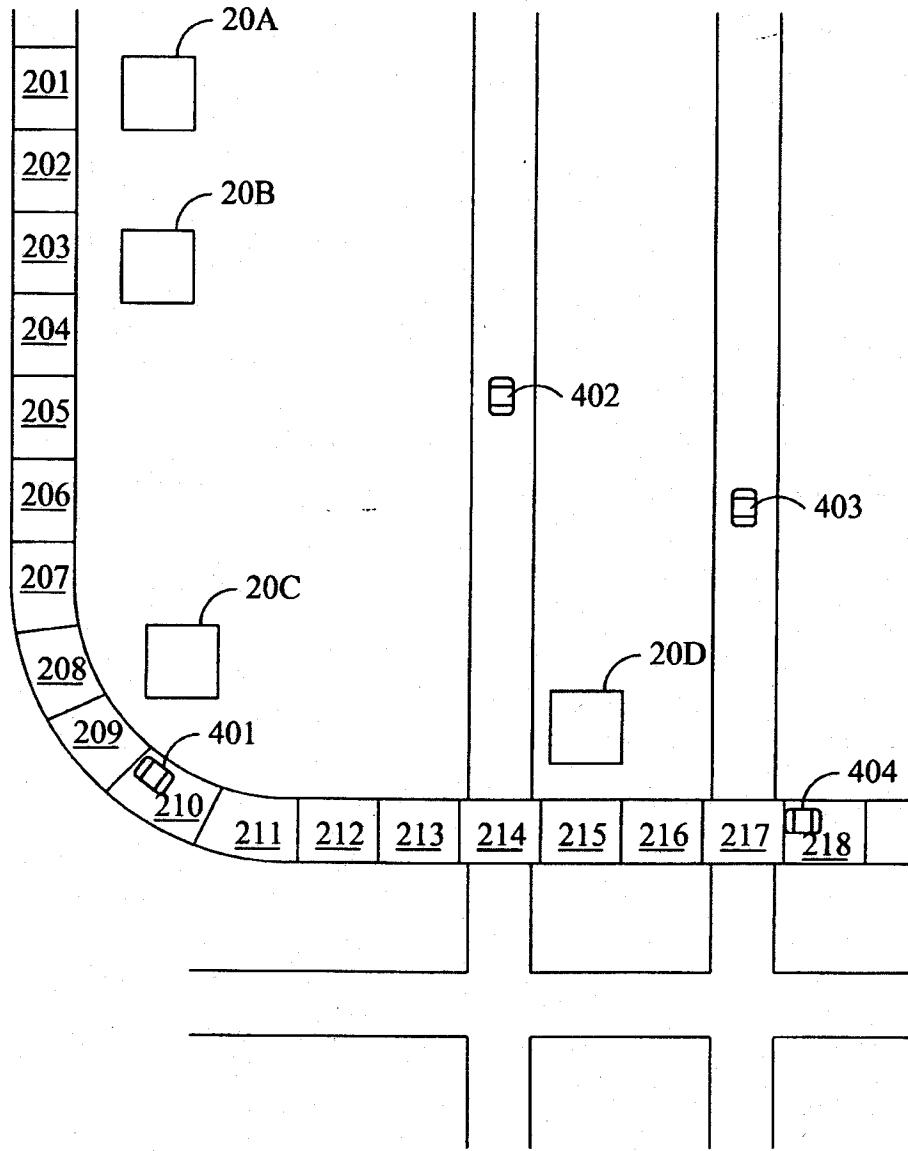

FIG. 11



LOCATION	LAT/LONG	ROAD	DIRECTION	VELOCITY
201	45°54'36"N/ 37°32'12"E	INTERSTATE	0°	55 MPH
202	⋮	LOCAL	27°	20 MPH
203		BYPASS	EAST	STOPPED
204		RESIDENTIAL	NW	⋮
205		⋮	⋮	
206				
207				
⋮				

FIG. 12

54

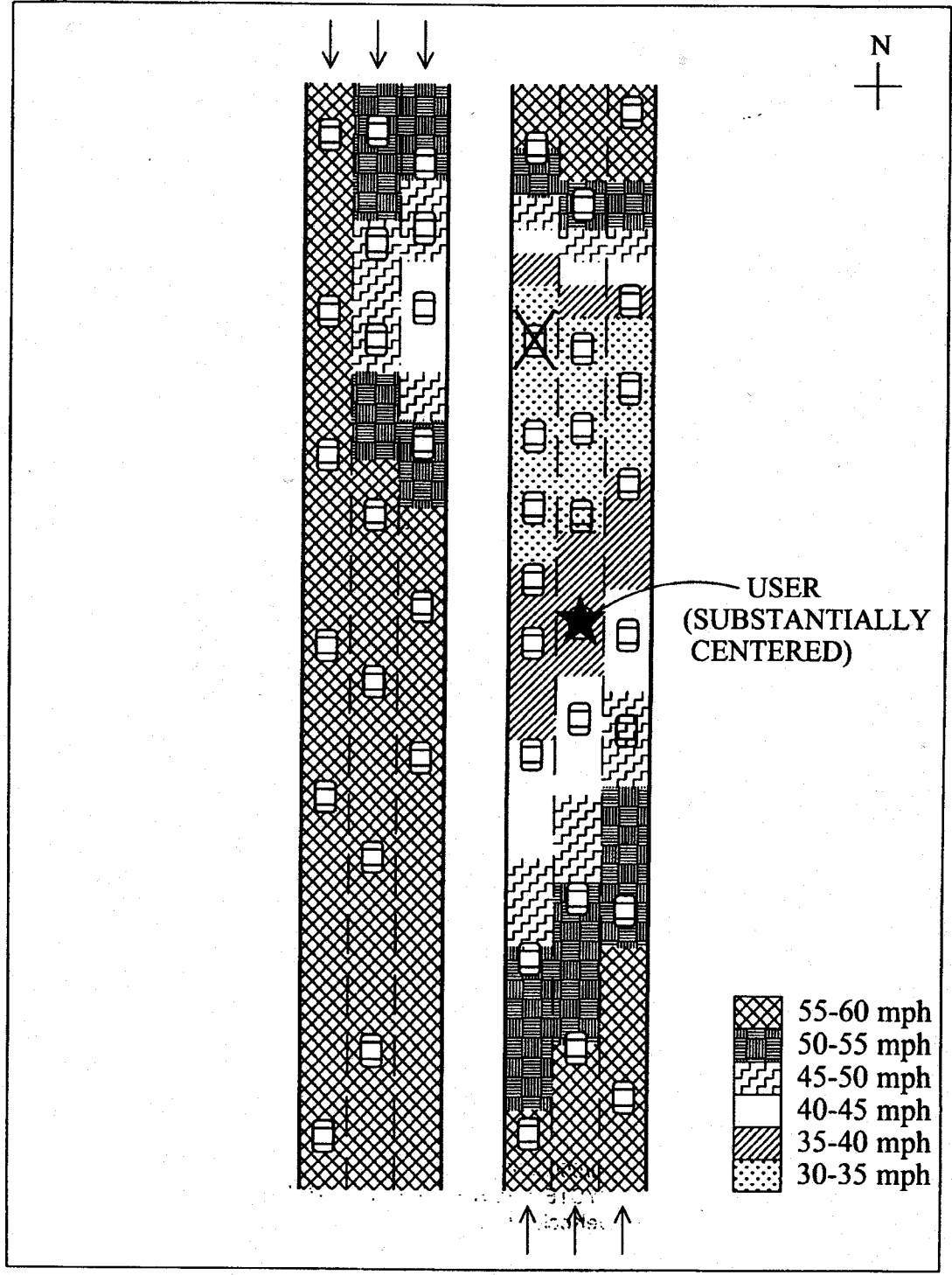

FIG. 13

54

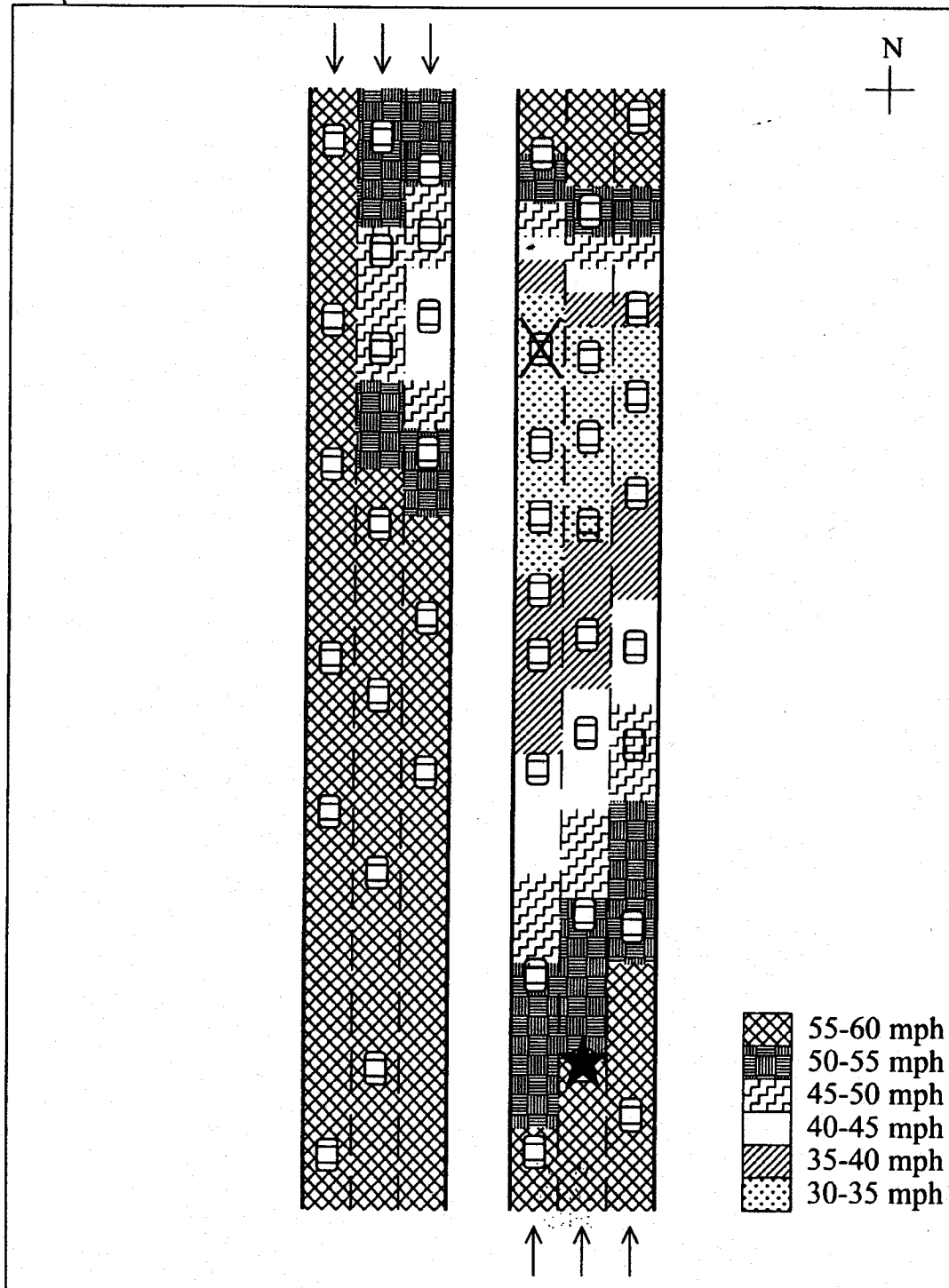

FIG. 14

AUG 0 8 2052 P.  
ENT & TRADEMARK OFFICE

COPY OF PAPER  
ORIGINALLY FROM

54

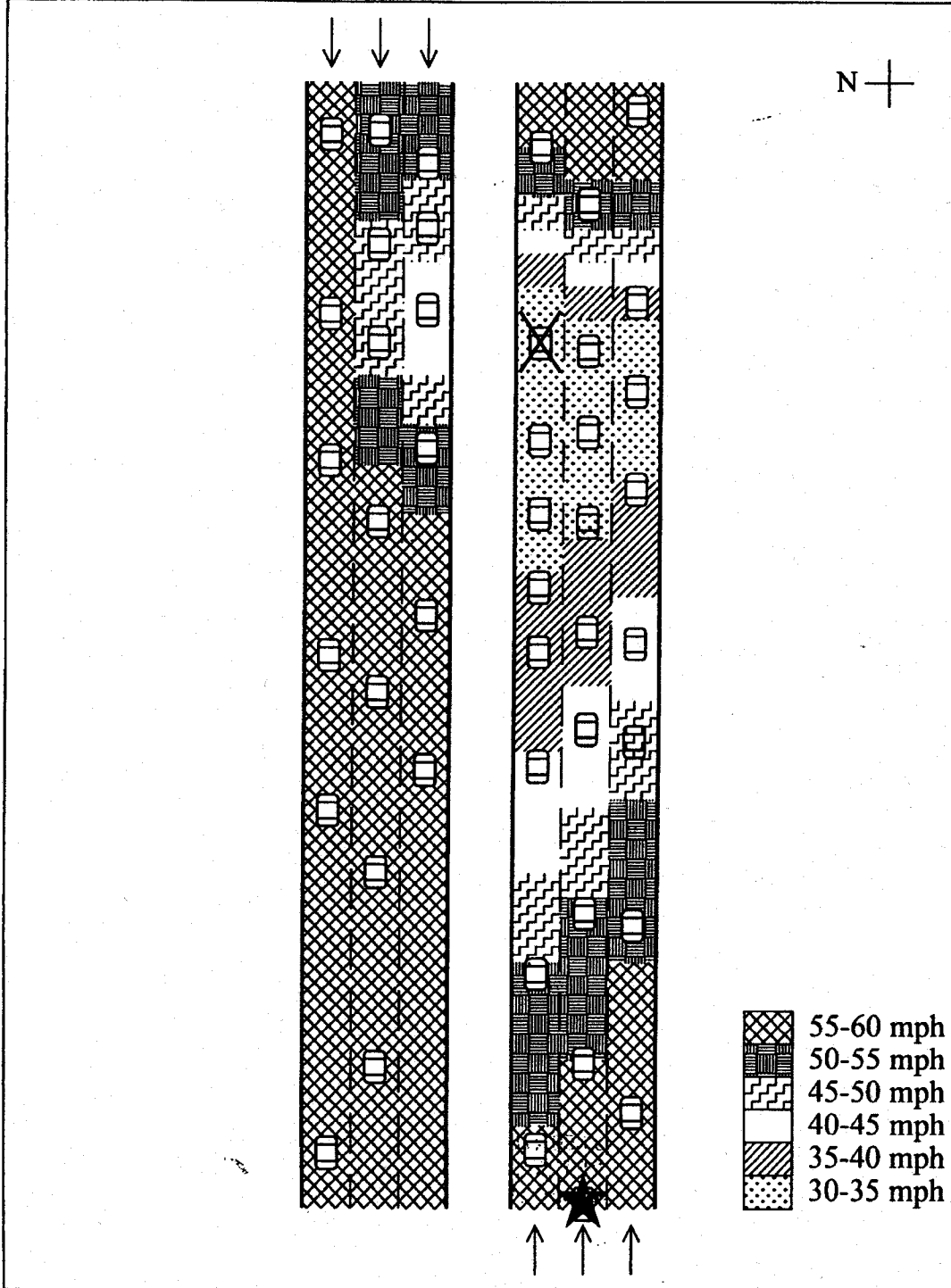

FIG. 15

U.S. PATENT & TRADEMARK OFFICE  
AUG 06 2002

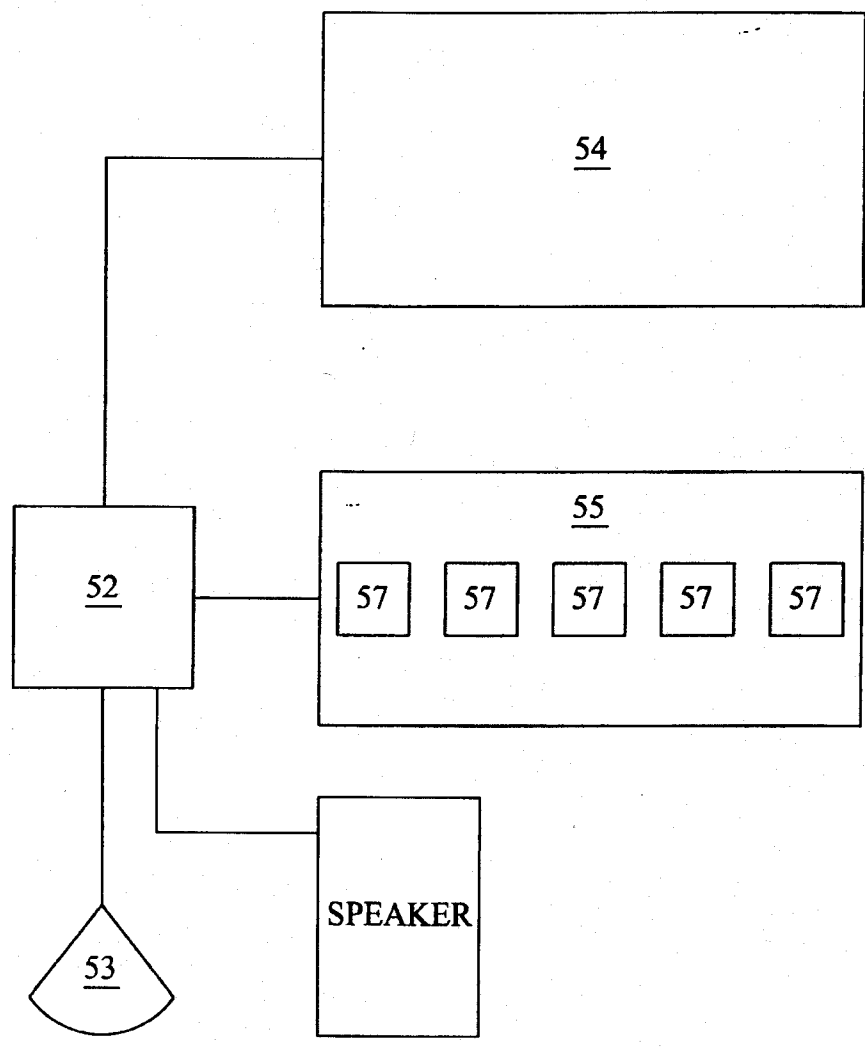
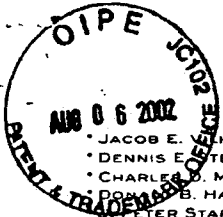

FIG. 16

RECEIVED  
AUG 09 2002  
GROUP 3600



09/550476  
LAW OFFICES

RG B #

**CHERNOFF, VILHAUER, MCCLUNG & STENZEL, LLP**

- \* JACOB E. VILHAUER, JR.
- \* DENNIS E. STENZEL
- \* CHARLES D. MCCLUNG
- \* DOUGLAS B. HASLETT
- \* PETER STAPLES
- \* WILLIAM O. GENY
- \* NANCY J. MORIARTY
- \* JULIANNE R. DAVIS
- \* KEVIN L. RUSSELL

INTELLECTUAL PROPERTY LAW  
INCLUDING PATENT, TRADEMARK,  
COPYRIGHT AND UNFAIR  
COMPETITION MATTERS

- \* TIM A. LONG
- \* KURT ROHLFS
- \* BRENNAN K. LEGAARD
- \* REGISTERED PATENT ATTORNEY
- DAVID S. FINE
- SENIOR LAW CLERK

1600 ODS TOWER  
601 S.W. SECOND AVENUE  
PORTLAND, OREGON 97204-3157  
TELEPHONE: (503) 227-5631  
FAX: (503) 228-4373

DANIEL P. CHERNOFF  
(1935-1995)

July 30, 2002

Our File: 7116.004

Box ISSUE FEE  
Commissioner for Patents  
Washington, D.C. 20231

Re: United States Patent Application Serial No. 09/550,476  
For: SYSTEM FOR PROVIDING TRAFFIC INFORMATION  
Filed: April 14, 2000

Dear Sir:

Enclosed are the following documents regarding the above-referenced patent application:

1. Transmittal letter;
2. 2002 Fee Transmittal Form in duplicate;
3. Form PTOL-85B, in duplicate with a certificate of mailing;
4. Check in the amount of \$649 for payment of the Issue Fee (\$640), and three advance copies of the patent (\$9); and
5. Acknowledgment postcard.

Additionally, on this date, we are submitting a Petition to Revive and corrected formal drawings to comply with the Notice of Draftsperson's Patent Drawing Review with copies only enclosed herewith.

The Commissioner is hereby authorized to charge payment of any additional fees or credit any overpayment to Deposit Account No. 03-1550. Duplicate copies of Fee Transmittal 2002 are enclosed.

Please address all notices regarding the payment of maintenance fees on the above-identified patent to Chernoff, Vilhauer, McClung & Stenzel, LLP at the then current address for payor number 000152.

Respectfully submitted,

Kevin L. Russell  
Reg. No. 38,292  
Attorney for Applicant

KLR:djs  
Enclosures

Exhibit E  
Page 307 of 311



Paper No. 15

**COPY MAILED**

**SEP 09 2002**

**OFFICE OF PETITIONS**

Bruce W. DeKock  
1600 ODS Tower  
601 S W Second Avenue  
Portland, OR 97204

In re Application of  
DeKock, et al.  
Application No. 09/550,476  
Filed: April 14, 2000  
Attorney Docket No.: BWD-7118.004  
For: SYSTEM FOR PROVIDING TRAFFIC  
INFORMATION

ON PETITION

This is a decision on the petition under 37 CFR 1.137(b), filed August 5, 2002, to revive the above-identified application.

The petition is **GRANTED**.

The application became abandoned May 21, 2002. The application was abandoned for failure to timely submit the issue fee, as required by the Notice of Allowance and Issue Fee Due, and for failure to timely submit new formal drawings, as required by the Notice of Allowability. The Notices were mailed February 20, 2002 and set a three (3) month statutory period of time for reply. Notice of Abandonment was mailed July 1, 2002.

This application will be forwarded to the Publications Division for processing into a patent.

Telephone inquiries concerning this matter may be directed to the undersigned at (703) 305-0310.

Alesia M. Brown  
Petitions Attorney  
Office of Petitions  
Office of the Deputy Commissioner  
for Patent Examination Policy



**RAM** Fee History  
Query  
Revenue Accounting and Management

Name/Number: 09550476

Total Records Found: 6

Start Date: Any Date

End Date: Any Date

Accounting Date	Sequence Num.	Tran Type	Fee Code	Fee Amount	Mailroom Date	Payment Method
04/27/2000	00000021	<u>1</u>	<u>201</u>	\$345.00	04/14/2000	OP
04/27/2000	00000022	<u>1</u>	<u>203</u>	\$162.00	04/14/2000	OP
07/26/2001	00000030	<u>1</u>	<u>217</u>	\$445.00	07/24/2001	OP
08/06/2002	00000071	<u>1</u>	<u>241</u>	\$640.00	08/05/2002	OP
08/08/2002	00000193	<u>1</u>	<u>242</u>	\$640.00	08/06/2002	OP
08/08/2002	00000194	<u>1</u>	<u>561</u>	\$9.00	08/06/2002	OP

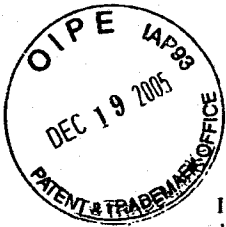

COMPLETED

OCS

**CERTIFICATE OF MAILING**

I hereby certify that this correspondence is being deposited with the U.S. Patent and Trademark Office as first class mail in an envelope addressed to: Commissioner for Patents, P.O. Box 1450, Alexandria, VA 22313-1450, on December 14, 2005.

Dated: December 14, 2005

  
Kevin L. Russell

Atty. Docket No.  
7116.0004

PATENT

**IN THE UNITED STATES PATENT AND TRADEMARK OFFICE**

Patentee: Bruce DeKock et al.

Customer No.: 00152

Patent No.: 6,466,862

Issue Date: October 15, 2002

Title: SYSTEM FOR PROVIDING TRAFFIC INFORMATION

**REQUEST FOR CORRECTION OF ATTORNEY DOCKET NO.**

Commissioner for Patents  
P.O. Box 1450  
Alexandria VA 22313-1450

Sir:

Patentee hereby requests that the Attorney Docket No. for the above-referenced patent be changed from "BWD-7118.004-" to -7116.0004-. A copy of the Maintenance Fee Statement marked up showing the requested change is enclosed.

Respectfully submitted,

CHERNOFF, VILHAUER, McCLUNG & STENZEL

By

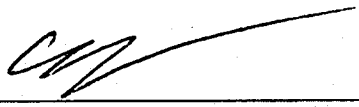
  
Kevin L. Russell, Reg. No. 38,292  
1600 ODS Tower  
601 S.W. Second Avenue  
Portland, OR 97204  
Tel: 503-227-5631  
Fax: 503-228-4373

Dated: December 14, 2005

Exhibit E  
Page 310 of 311

AG 120 (Rev. 3/04)

**SOLICITOR**

TO: <b>Mail Stop 8</b> <b>Director of the U.S. Patent and Trademark Office</b> P.O. Box 1450 Alexandria, VA 22313-1450	OCT 23 2008 <b>REPORT ON THE FILING OR DETERMINATION OF AN ACTION REGARDING A PATENT OR TRADEMARK</b> U.S. PATENT & TRADEMARK OFFICE
---	--

In Compliance with 35 U.S.C. § 290 and/or 15 U.S.C. § 1116 you are hereby advised that a court action has been filed in the U.S. District Court Eastern District of Texas on the following  Patents or  Trademarks:

DOCKET NO. 2:08-cv-404	DATE FILED 10/20/2008	U.S. DISTRICT COURT Eastern District of Texas
PLAINTIFF TRAFFIC INFORMATION, LLC		DEFENDANT HTC USA, INC., MOTOROLA, INC., PALM, INC., PANTECH WIRELESS, INC., SAMSUNG TELECOMMUNICATIONS AMERICA, LLC, ET AL.
PATENT OR TRADEMARK NO.	DATE OF PATENT OR TRADEMARK	HOLDER OF PATENT OR TRADEMARK
1 6,785,606	8/31/2004	Bruce W. DeKock, Kevin L. Russell, and Richard J. Qian
2 6,466,862	10/15/2002	Bruce W. DeKock, Assignee
3		
4		
5		

In the above—entitled case, the following patent(s)/ trademark(s) have been included:

DATE INCLUDED	INCLUDED BY		
	<input type="checkbox"/> Amendment <input type="checkbox"/> Answer <input type="checkbox"/> Cross Bill <input type="checkbox"/> Other Pleading		
PATENT OR TRADEMARK NO.	DATE OF PATENT OR TRADEMARK	HOLDER OF PATENT OR TRADEMARK	
1			
2			
3			
4			
5			

In the above—entitled case, the following decision has been rendered or judgement issued:

DECISION/JUDGEMENT
--------------------

CLERK	(BY) DEPUTY CLERK	DATE
-------	-------------------	------

Copy 1—Upon initiation of action, mail this copy to Director    Copy 3—Upon termination of action, mail this copy to Director  
 Copy 2—Upon filing document adding patent(s), mail this copy to Director    Copy 4—Case file copy