



US006773172B1

(12) **United States Patent**
Johnson et al.

(10) **Patent No.:** **US 6,773,172 B1**
(45) **Date of Patent:** **Aug. 10, 2004**

- (54) **QUICK-RELEASE CLAMP FOR PHOTOGRAPHIC EQUIPMENT**
- (75) Inventors: **Joseph M. Johnson**, P.O. Box 6531, Los Osos, CA (US) 93412; **Mark W. Ames**, San Luis Obispo, CA (US)
- (73) Assignee: **Joseph M. Johnson**, Los Osos, CA (US)
- (*) Notice: Subject to any disclaimer, the term of this patent is extended or adjusted under 35 U.S.C. 154(b) by 0 days.
- (21) Appl. No.: **10/645,419**
- (22) Filed: **Aug. 20, 2003**
- (51) Int. Cl.⁷ **G03B 17/00**
- (52) U.S. Cl. **396/428; 248/187.1**
- (58) Field of Search 396/419, 420, 396/422, 428; 248/187.1

- (56) **References Cited**
- U.S. PATENT DOCUMENTS**

2,824,504 A	2/1958	Bethmann
2,840,334 A	6/1958	Cauthen
3,356,325 A	12/1967	Schnase
3,677,509 A	7/1972	O'Connor
4,929,973 A	5/1990	Nakatani
5,601,265 A	2/1997	Lopez
5,870,641 A	2/1999	Chrosziel
6,196,504 B1	3/2001	Lemke
6,435,738 B1	8/2002	Vogt

- FOREIGN PATENT DOCUMENTS**

JP	97395	4/2000
----	-------	--------

Primary Examiner—David M. Gray
(74) *Attorney, Agent, or Firm*—Chernoff, Vilhauer, McClung & Stenzel, LLP

(57) **ABSTRACT**

A clamp for securely mounting photographic equipment to a support, such as a tripod.

29 Claims, 10 Drawing Sheets

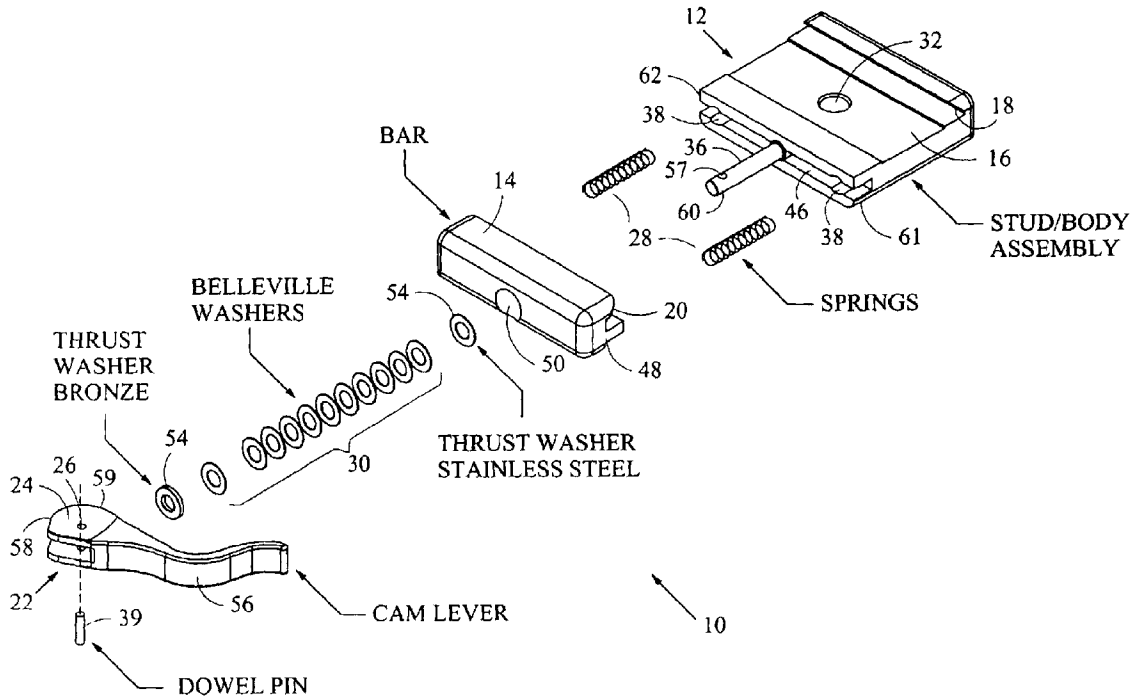

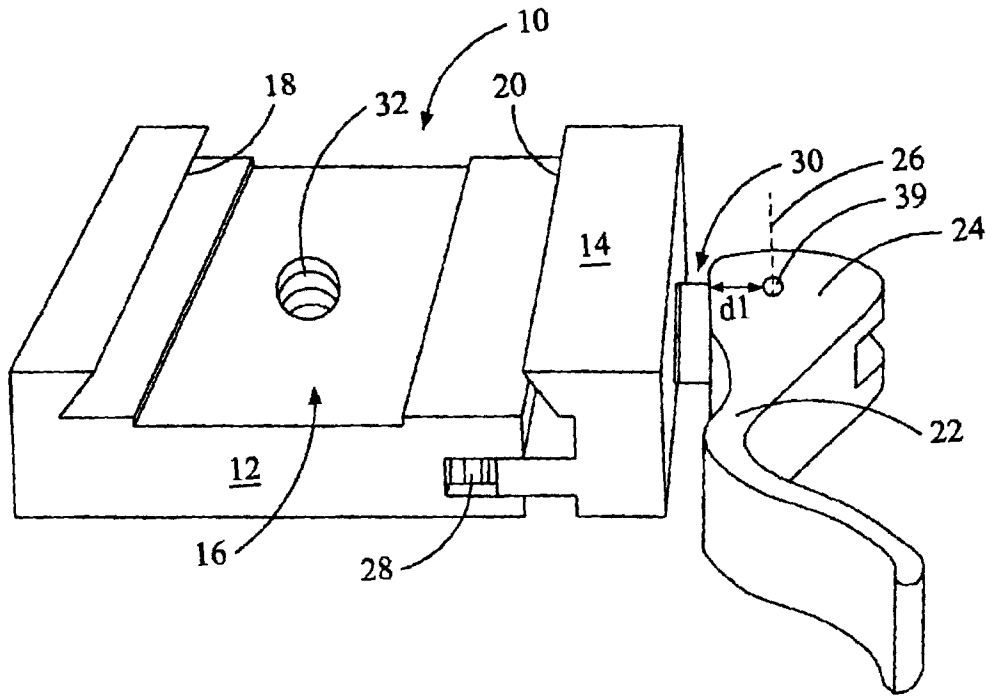

FIG. 1

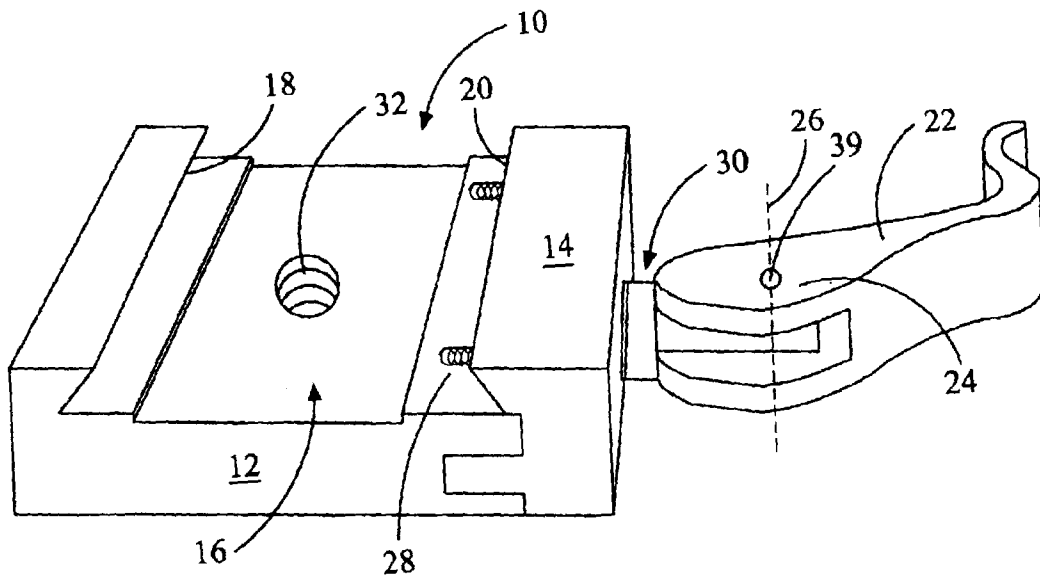

FIG. 2

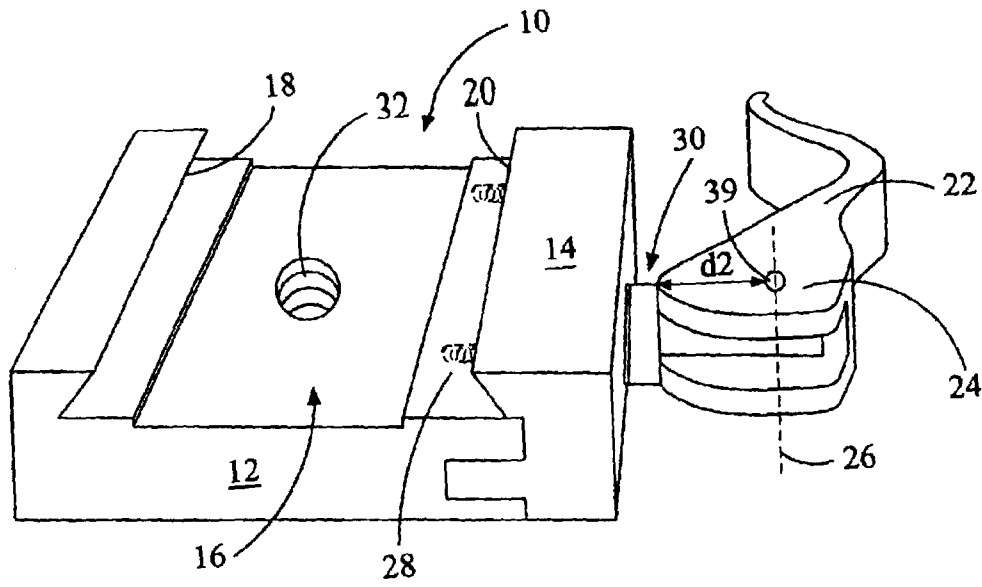

FIG. 3

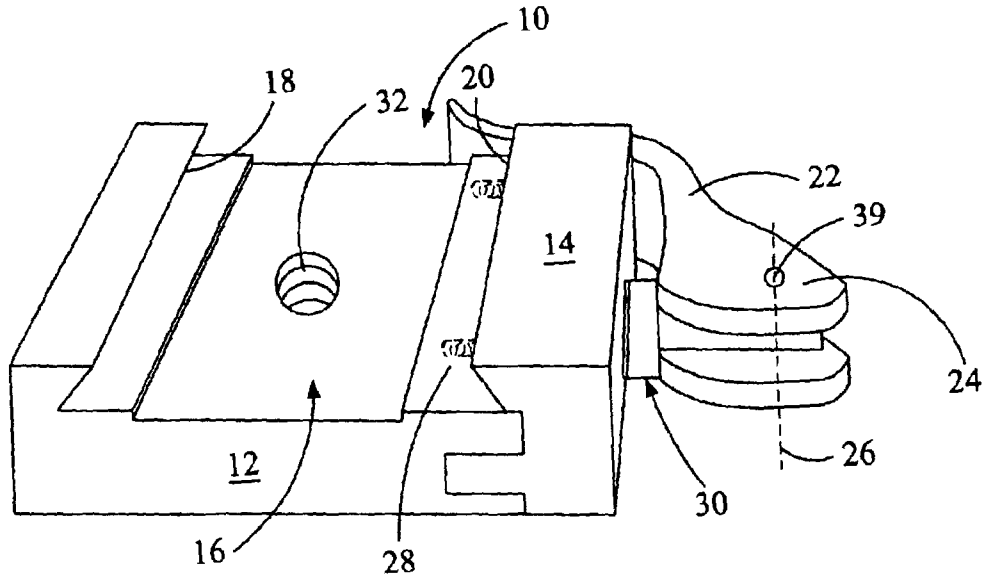

FIG. 4

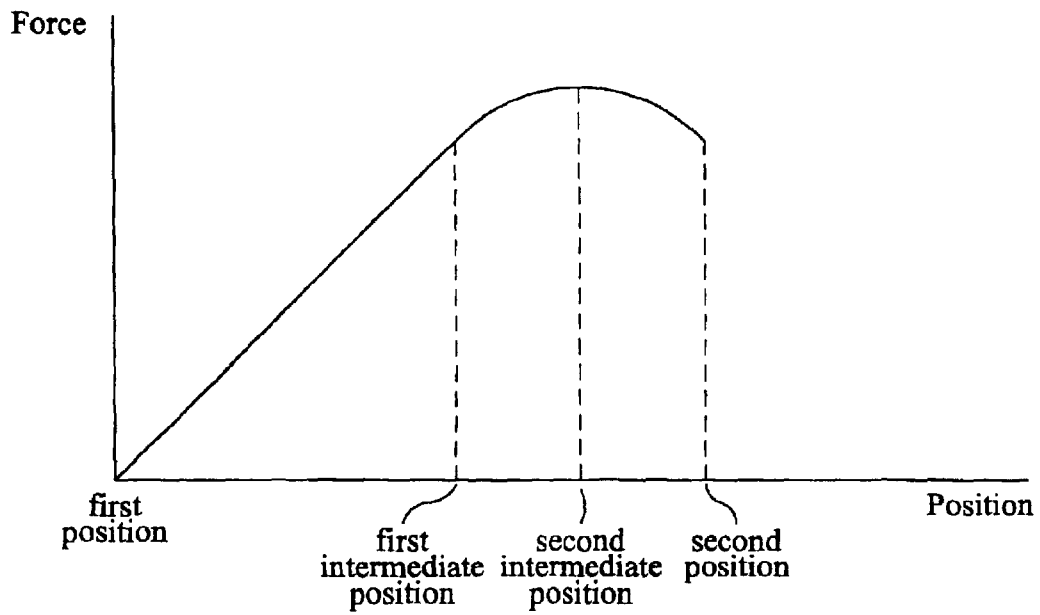

FIG. 5

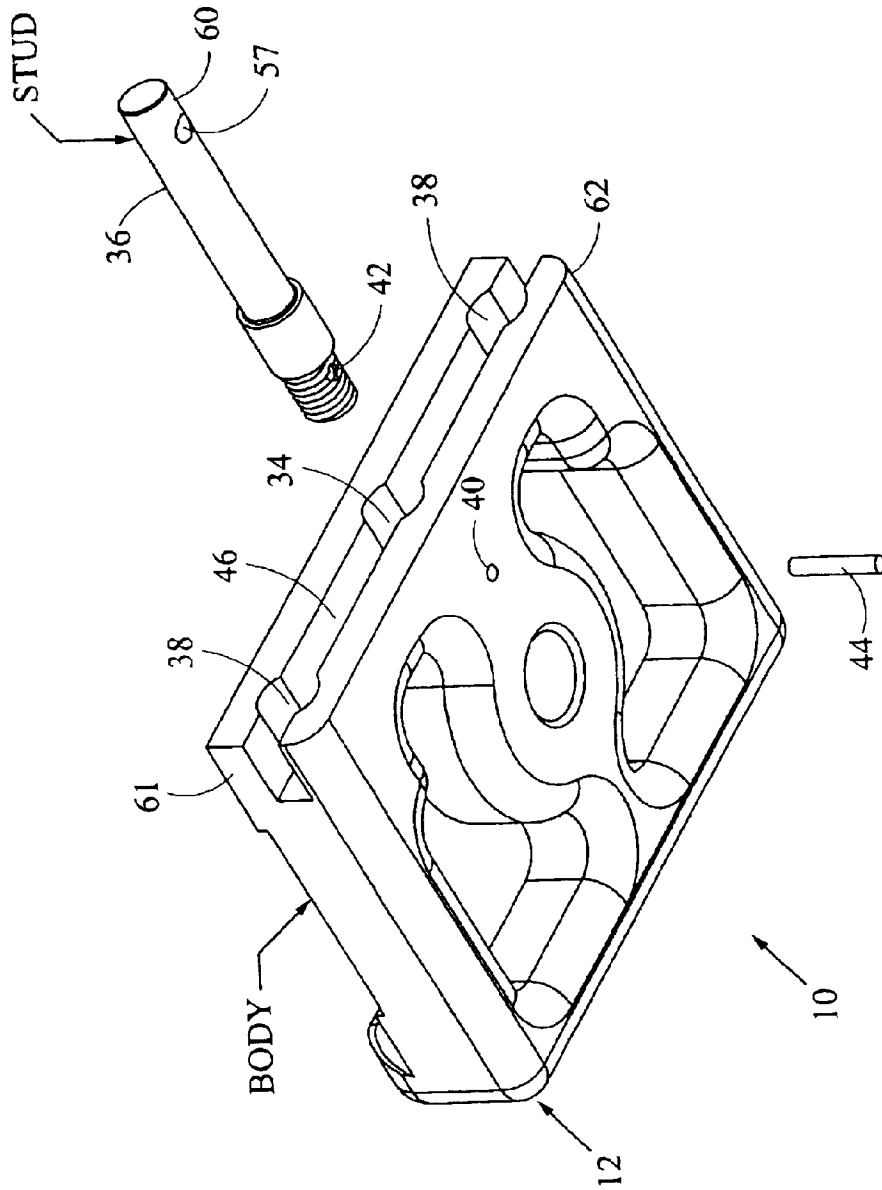

FIG. 7

FIG. 8B

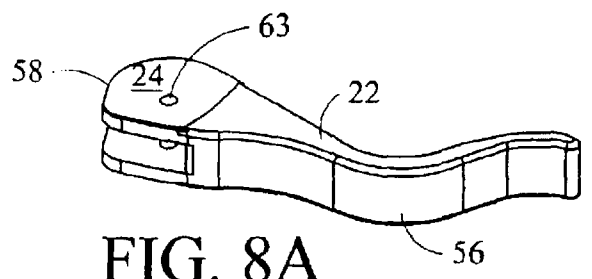
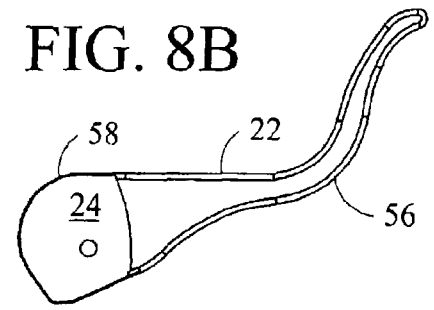

FIG. 8A

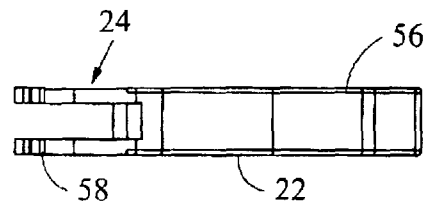

FIG. 8C

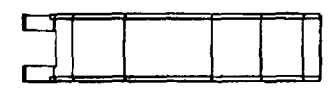

FIG. 8E

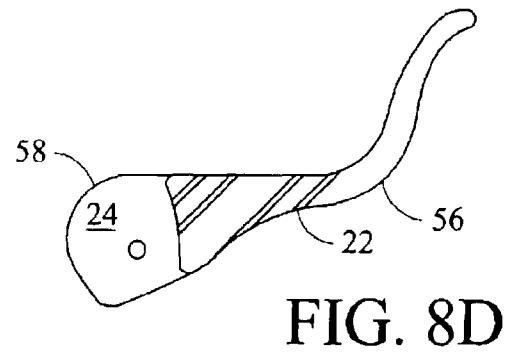

FIG. 8D

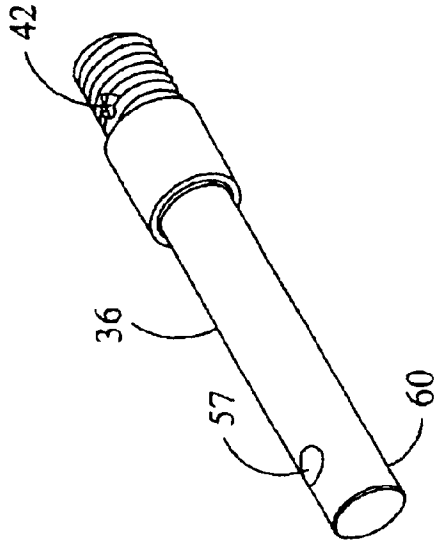

FIG. 9A

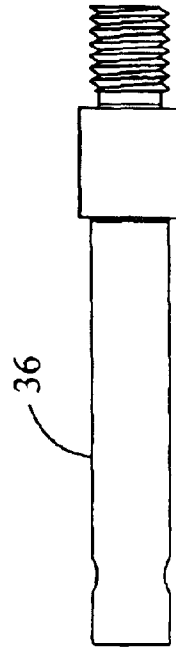

FIG. 9C

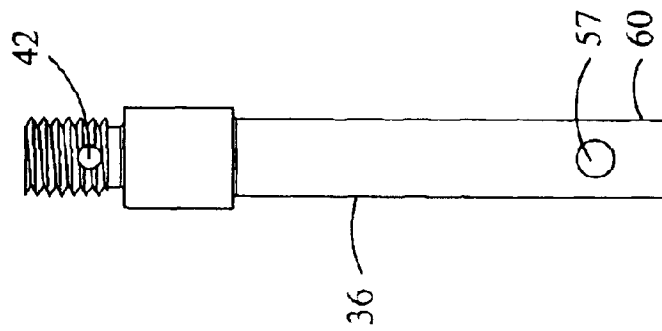

FIG. 9B

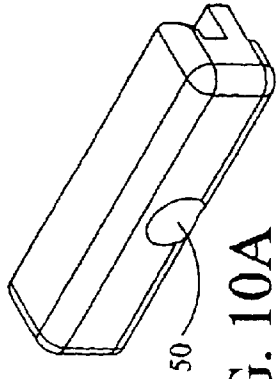

FIG. 10A

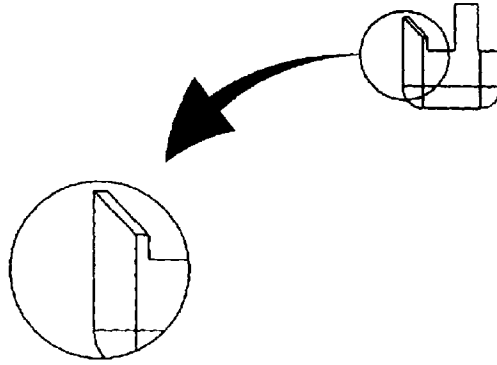

FIG. 10E

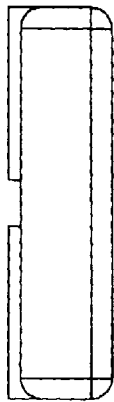

FIG. 10B

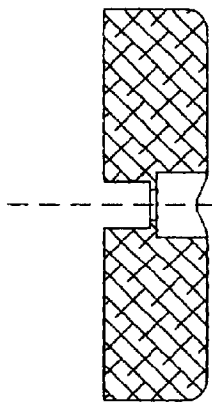

FIG. 10C

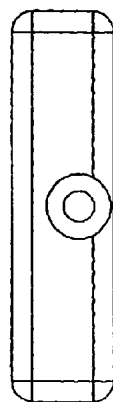

FIG. 10D

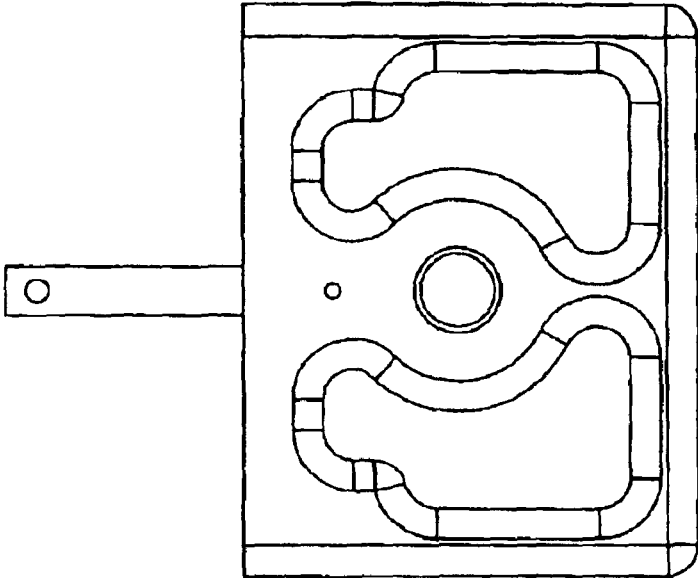

FIG. 11



FIG. 12C

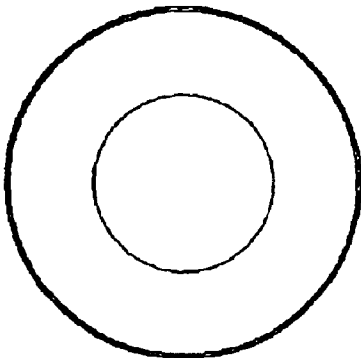

FIG. 12B

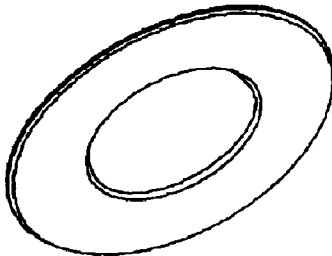

FIG. 12A

1

QUICK-RELEASE CLAMP FOR PHOTOGRAPHIC EQUIPMENT

BACKGROUND OF THE INVENTION

The present invention relates to a clamp for mounting photographic equipment to a support, such as a tripod or ball head.

Photographic equipment may be mounted to a camera stand in a variety of ways. Some camera bodies, for example, have threaded sockets in their base so they can be directly mounted to a bolt that extends upwardly from the support. The camera body is positioned over the support so that the bolt fits within the socket and the camera body is spun around several times to screw the camera body to the support. Alternatively, and particularly when a heavy, elongate camera lens is attached to a camera body, the camera lens will include a support having a threaded socket positioned below the lens so that the lens may be mounted to the support in the same manner as a camera body.

These methods take an appreciable amount of time and require care to ensure that the threads of the stud are properly aligned with the threads in the socket. Further, there is often insufficient time to screw the camera body or lens to the tripod before a particular shot should be taken. This lack of time requires that the camera either be held in-hand, potentially resulting in image blur from the shake of the hand, or that the shot be missed altogether.

These difficulties can be reduced by using a quick-release clamp to mount photographic equipment to a support. Such quick-release clamps are typically designed to screw onto the bolt of the support while the photographic equipment is releasably secured to the upper surface of the clamp so that it can quickly be secured to, or released from, the support. To secure photographic equipment to such a quick-release clamp, the photographic equipment such as a camera body will typically include two parallel, opposed rails extending from its base. The opposed rails may be provided by the equipment or in the form of a plate secured to the equipment. The rails are spaced apart so that they fit within an upwardly facing channel defined by the clamp. The clamp includes a lever that moves between two positions to adjust the spacing between the side walls of the channel so that, when in a first, locking position, the channel grips the rails connected to the camera system and when in a second, released position, the channel disengages the rails so that the photographic equipment may be lifted from the clamp. In this manner, the lever may be used to quickly secure or release the photographic equipment from the support.

Unfortunately, existing quick-release clamps have certain disadvantages. In order to provide for relative movement of the side walls of the channel, one or more springs apply an outward force to the side walls, so that they move apart as the lever is moved to the second position. This outward force tends to likewise push the lever away from the first, locking position, thus loosening the fitting between the photographic equipment and the clamp. Further, as a result of usage over time, the lever and the clamp tend to loosen from one another, thereby widening the spacing of the channel walls in the locked position and thus loosening the fitting between the photographic equipment and the clamp when in the locked position.

Further, the lever in existing quick-release clamps is positioned solely on an outer lateral side of the clamp, underneath one side of the camera body. This position makes it awkward to reach underneath the camera to operate the

2

lever. This problem is exacerbated with quick release clamps that use an adjustment screw to adjust the spacing between the side walls of the channel rather than a lever, as it is difficult to rotate the screw while the camera is mounted over it.

It is therefore desired to provide a clamp for easily, quickly, and securely mounting photographic equipment to a support.

BRIEF DESCRIPTION OF THE DRAWINGS

FIG. 1 is a perspective view of a clamp that incorporates aspects of the present invention where the clamp has a lever in a disengaged position where photographic equipment may be inserted into, or removed from, the clamp.

FIG. 2 is a perspective view of the clamp of FIG. 1 showing the lever in a first intermediate position between an engaged and disengaged position, where the channel of the clamp is at its minimum width.

FIG. 3 is a perspective view of the clamp of FIG. 1 showing the lever in a second intermediate position between an engaged and disengaged position, where the channel of the clamp is at its minimum width and pivot axis of the lever is at its maximum distance from the channel.

FIG. 4 is a perspective view of the clamp of FIG. 1 showing the lever in an engaged position where the photographic equipment may be secured to the clamp.

FIG. 5 is a graph of a force profile generated by the clamp of FIG. 1 as the lever is moved over a range of motion from a first position to a second position.

FIG. 6 is an assembly drawing of the clamp shown in FIG. 1.

FIG. 7 is an assembly drawing of a portion of the clamp shown in FIG. 1 showing the manner in which the stud is secured to the clamp.

FIGS. 8A-8E are views of the cam lever of the clamp of FIG. 1.

FIGS. 9A-9C are views of the stud shown in FIG. 6.

FIGS. 10A-10E are views of the adjustable arm shown in FIG. 6.

FIG. 11 is a bottom view of the stud shown in FIG. 6 inserted into the body shown in FIG. 6.

FIGS. 12A-12C are views of a thrust washer shown in FIG. 6.

DETAILED DESCRIPTION OF THE PREFERRED EMBODIMENT

FIG. 1 shows a clamp 10 that comprises a body 12 and an adjustable arm 14 (shown in FIGS. 10A-10E) that together form a channel 16 having opposed side walls 18 and 20. The body 12 may define an opening 32 through which the clamp 10 may be secured to the upper portion of a tripod or other support. The adjustable arm 14 is slidably engaged along the cantilevered portion 59 of a stud 36 (shown in FIGS. 6, 7, and 9A-9C) securely mounted in the body 12, as shown in FIG. 11. Movement of the adjustable arm 14 selectively adjusts the width of the channel 16 and is accomplished through manual operation of a lever 22 fastened to the distal end 60 of the stud 36. The lever 22, attached to the adjustable arm 14, permits quick adjustment of the spacing between the side walls 18 and 20 so that the channel 16 may selectively either grip or release a pair of rails attached to the base of a camera body (not shown). Each respective side wall 18 and 20 is preferably angled upward and inward to facilitate engagement with such rails. In this manner, photographic

3

equipment may be quickly engaged or released from a tripod or other support.

The lever 22 may be a cam lever that includes a cam portion 24 that rotates about a pivot axis 26 as the cam lever is moved between a first, unlocked position (shown in FIG. 1) and a second, locked position (shown in FIG. 4). The cam portion 24 has an asymmetrical shape about the pivot axis 26 so that the lever 22 pushes the adjustable arm 14 inward as the lever 22 is moved from a first position for releasing photographic equipment from the clamp 10 to a second position for gripping photographic equipment to the clamp 10. Conversely, as the lever 22 is moved from the second position to the first position, a pair of counterforce springs 28, housed within the body 12, push outward on the adjustable arm 14 so that the channel 16 expands.

The outwardly directed force applied by the springs 28 on the adjustable arm 14 is at a maximum when the lever 22 is in the second position, i.e. when the channel 16 is intended to grip photographic equipment. The force applied by the springs 28 therefore acts to undesirably loosen the grip on the photographic equipment. The disclosed clamp 10, however, includes a locking member 30 that prevents any outward movement of the adjustable arm 14 that might otherwise result from the force applied by the springs 28. The locking member 30 may be substantially compressible, such as a compression spring, and interposed between the lever 22 and the adjustable arm 14. FIG. 6, for example, shows a series of Belleville washers 30 that together operate as a compression spring. Alternatively, the locking member 30 could be a helical compression spring or any other appropriate force generating member. Further, the locking member 30 may be interposed between the adjustable arm 14 and the body 12. The locking member 30 may preferably apply an inwardly-directed force on the adjustable arm 14 that increases as the lever 22 is moved from the first position towards the second position. The inward force applied on the adjustable arm 14 by the locking member 30 may preferably be greater than the outward force applied by the springs 28 when the lever 22 is in the second position. Also, the lever 22 may preferably include an over-center detent position.

The manner in which clamp 10 may be operated to achieve the foregoing advantages is seen in reference to FIGS. 1-4. FIG. 1 shows the clamp 10 where the lever 22 is in the first position, i.e. the released position. In this first position, the adjustable arm 14 is spaced apart from the body 12 by an applied force from the springs 28, thus widening the channel 16 to allow the insertion or removal of photographic equipment. The cam portion 24 is oriented such that the locking member 30, which in this instance is a series of Belleville washers that act as a compression spring, is sufficiently relaxed so as to not apply a sufficient inward force on the adjustable arm 14 to overcome the outward force of the springs 14. In this position, the cam portion 24 preferably abuts the locking member 30 at a minimum distance d_1 from the pivot axis 26. As the lever 22 is moved from the first position toward the second position, the cam portion 24 pushes the locking member 30 and the adjustable arm 14, inward. The locking member 30 begins to compress to counterbalance the outward force of the springs 28 applied to the adjustable arm 14 as it moves inward.

FIG. 2 shows the lever 22 in a first intermediate position where the lever 22 has been moved to a position where the adjustable arm 14 is flush with the body 12. In this position, the forces applied by the locking member 30 and the springs 28 counterbalance each other; further movement of the lever 22 towards the second position, however causes the inward force applied by compression of the locking member to

4

increase over that of the springs 28 because the adjustable arm 14 may not move any further while the locking member 30 will continue to compress.

FIG. 3 shows the lever 22 in a second intermediate position where the locking member 30 is applying a maximum inward force on the adjustable arm 14. This is a position where the cam portion 24 preferably abuts the locking member 30 at a maximum distance d_2 from the pivot axis 26. In this position, the inward force applied by the locking member 30 to the adjustable arm 14 is substantially greater than the outward force applied by the springs 28. Further movement of the lever 22 toward either the first or second position will relax the locking member 30 with respect to the maximum inward force as the distance from the pivot axis 26 on which the locking member 30 abuts the cam portion 24 decreases.

FIG. 4 shows the lever 22 in the second position. In this position, the lever 22 is in an over-center detent configuration such that movement of the lever 22 toward the first position will act to compress the locking member 30. Thus the locking member 30 resists movement of the lever 22 toward the first position. Preferably, when in this position, the inward force applied by the locking member 30 to the adjustable arm 14 is still greater than the outward force applied by the springs 28. Alternatively, the two forces could be precisely counterbalanced. In this manner, the adjustable arm 14 is locked into place because the springs 28 do not apply a sufficient force to overcome that force applied by the locking member 30.

The locking member 30 preferably applies a force to the adjustable arm 14 and the lever 22 that varies with the position of the lever 22. The force preferably increases as the lever is moved from the first position towards the second position. The force preferably reaches a maximum before the lever reaches the second position. More preferably, the force applied by the locking member 30 is less than that maximum when in the second position, so that the force applied by the locking member also increases as the lever is moved from the second position towards the first position.

The locking member 30 together with the lever 22 will achieve a force profile generally depicted in FIG. 5. This figure indicates that as the lever 22 is moved over a range of motion extending from the first position to the second position, the force increases to a maximum at a second intermediate position and then decreases as the lever 22 continues to the second position.

It should also be noted from this figure FIG. 5 the adjustable arm 14 may cease its inward motion at a first intermediate position before the locking member has reached its maximum force. This may be preferable so that the inward force applied by the locking member 30 on the adjustable arm 14, when the lever is in the second position, can still overcome the outward force applied by the springs 28 even though the force applied by the locking member 30 has fallen from its maximum. It should be further noted that the movement of the adjustable arm 14 corresponds to the movement of the lever. Therefore, it is desirable that the lever move through a large percentage of its range of motion before the adjustable arm ceases to move, and achieve a maximum force in the remaining range of motion of the lever. For that reason, the force applied by the locking member 30 in the disclosed clamp 10 achieves its maximum value at approximately 80-90% of the lever's range of motion. It should be understood, however, that other embodiments may achieve a maximum force anywhere along the lever's range of motion, but preferably greater than 50%.

5

The force profile depicted in FIG. 5 is smooth, i.e. as the lever is moved from the first position, the force increases continuously to a maximum and decreases continuously until the lever reaches the second position. Alternative embodiments may design a lever that permits the force profile to decrease at certain intervals on the lever's path from the first position to the second intermediate position of maximum force, or to increase on the lever's path from that second intermediate position to a lesser force at the second position, or both. Preferably, however, the force profile is increasing over at least 65% of the lever's path from the first position to the second intermediate position and is decreasing over at least 65% of the path from the second intermediate position to the second position.

Though the force profile depicted in FIG. 5 is achieved by using a lever 22 in conjunction with the locking member 30, it should be understood that levers of other shapes may be used to achieve the same or similar force profiles. Further, other structures may be substituted for the lever, such as a plunger or a button.

Referring to FIGS. 6 and 7, the clamp 10 may comprise a body 12 constructed of any sufficiently rigid material such as metal, plastic, or composite material. The body 12 preferably defines the side wall 18 of the channel 16 as well as a central opening 32 by which the clamp 10 may be secured to a tripod or other support using a bolt, pin, or other similar protrusion. The opening 32 may be threaded to receive a bolt, or alternately may not be threaded such that interconnection with a tripod or other support may be made using a wing nut or other fastener.

The body 12 may also define a sleeve 34 (shown in FIG. 7) into which the stud 36 may be inserted. The stud 36 and the sleeve 34 are preferably threaded to ensure a rigid connection. If further means are desired to ensure a rigid connection between the stud 36 and the body 12, they may each define aligned holes 40 and 42 through which a fastening pin 44 may be inserted. Alternatively, a thread locking compound may be used. The body preferably also defines two symmetrically opposed sockets 38 into which the springs 28 may be inserted. The sockets 38 and the sleeve 34 may also preferably be parts of a slot 46 defined by the body 12.

The adjustable arm 14 preferably defines the side wall 20 as well as a ledge 48 sized to fit snugly within the slot 46. The springs 28, when inserted into their respective sockets 38 will push on the ledge 46 as the adjustable arm is engaged with the body 12. The adjustable arm 14 may also define a partially bored opening 50 so that the opening 50 may simultaneously retain the locking member 30 within itself while permitting the stud 36 to extend completely through the adjustable arm 14.

The locking member 30 may comprise a plurality of adjacent Belleville washers that together function as a compression spring. Optionally, a thrust washer 54 (shown in FIGS. 6 and 12A-12C) may be located at either or each end of the plurality of Belleville washers.

Referring to FIGS. 8A-8E, the lever 22 may comprise a handle portion 56 and a yoke 58. The yoke 58 may also define the cam portion 24 that, as previously described, operates the locking member 30 as the lever 22 is rotated. The yoke 58 preferably receives the distal end 60 of the stud 36. The stud 36 may be secured to the yoke 58 using a dowel pin 39 that is inserted into aligned openings 57 and 63 formed by the stud 36 and the yoke 58, respectively.

As can be seen by FIG. 6, the clamp 10 may be assembled by first inserting the stud 36 and the springs 28 into the body

6

12. The adjustable arm 14 may then be pushed against the springs 28 until the adjustable arm 14 is engaged with the body 12 and the stud 36 protrudes through the adjustable arm 14. The locking member 30, which may comprise a series of washers 52 and 54, may be engaged over the stud 36 to fit within the partially bored opening 50 within the adjustable arm 14. The lever 22 may then be secured to the distal end 60 of the stud 36 to secure the assembly in place.

Referring to FIGS. 8A-8E, the cam lever 22 comprises a shape that assists the convenient operation of the clamp 10. Existing clamps employ levers that are exclusively positioned to one of the lateral sides of the clamp. Camera bodies are typically positioned directly over these existing levers, which often makes them difficult to reach when engaging or releasing the clamp. The cam lever 22, however, includes a handle portion 56 that extends from the yoke 58. The handle portion 56 is elongate and has a sufficient length to extend beyond, and curve around, a lateral corner 61 of the clamp 10 when the cam lever is in the second, or locked position as seen in FIG. 4. The cam lever also extends beyond the opposed lateral corner 62 when the cam lever is in the first position as seen in FIG. 1. The cam lever 22 therefore is easily accessible even cured to the clamp.

The terms and expressions that have been employed in the foregoing specifications are used therein as terms of description and not of limitation, and there is no intention, in the use of such terms and expressions, of excluding equivalents of the features shown and described or portions thereof, it being recognized that the scope of the invented is defined and limited only the claims that follow.

What is claimed is:

1. An apparatus for engaging photographic equipment to a support, said apparatus comprising:
 - (a) a member defining a channel having a first side wall capable of lateral movement with respect to a second side wall;
 - (b) a lever capable of causing said lateral movement; and
 - (c) a substantially compressible member operably interconnected between said lever and said first side wall.
2. The apparatus of claim 1 where said lever is a cam lever.
3. The apparatus of claim 1 where said substantially compressible member is a spring.
4. The apparatus of claim 3 where said spring comprises a series of Belleville washers.
5. An apparatus for engaging photographic equipment to a support, said apparatus comprising:
 - (a) a member defining a channel having a first side wall capable of lateral movement with respect to a second side wall between a first location and a second location, where said second location is spaced further from said second side wall than is said first location; and
 - (b) a lever and a substantially compressible member operably interconnected between said lever and said first side wall, said lever and said substantially compressible member together capable of causing said lateral movement and said lever moveable between a first position associated with said second location and a second position associated with said first location, said second position being an over-center detent.
6. The apparatus of claim 5 including a substantially compressible member operably interconnected between said lever and said first side wall.
7. The apparatus of claim 5 where said substantially compressible member maintains said lever in said detent position.

7

8. An apparatus for engaging a photographic equipment to a support, said apparatus comprising:

- (a) a member defining a channel having a first side wall capable of lateral movement with respect to a second side wall between a first location and a second location, where said second location is spaced further from said second side wall than is said first location;
- (b) a lever capable of causing said lateral movement and moveable between a first position associated with said second location and a second position associated with said first location; and
- (c) a force generating member capable of applying a force to said first side wall and said lever where said force increases when said lever is in said first position and is moved towards said second position.

9. The apparatus of claim 8 where said force generating member is a compression spring.

10. The apparatus of claim 8 where said compression spring comprises a plurality of Belleville washers.

11. An apparatus for engaging photographic equipment to a support said apparatus comprising:

- (a) a first member defining a channel having a first side wall capable of lateral movement with respect to a second side wall;
- (b) a second member capable of causing said lateral movement and moveable between a first position and a second position;
- (c) a third member capable of applying force to said first side wall and said second member where said force increases when said second member is in said first position and is moved towards said second position and said force increases when said second member is in said second position and is moved towards said first position.

12. The apparatus of claim 11 where said second member is moveable to an intermediate position between said first position and said second position and where said force decreases when said second member is moved from said intermediate position towards either said first position or said second position.

13. The apparatus of claim 12 where said second member has a range of motion from said first position to said second position and said intermediate position is located between 50 percent and 90 percent of said range of motion.

14. The apparatus of claim 12 where said second member has a range of motion from said first position to said second position and said intermediate position is located between 60 percent and 90 percent of said range of motion.

15. The apparatus of claim 12 where said second member has a range of motion from said first position to said second position and said intermediate position is located between 70 percent and 90 percent of said range of motion.

16. The apparatus of claim 12 where said second member has a range of motion from said first position to said second position and said intermediate position is located between 80 percent and 90 percent of said range of motion.

17. An apparatus for engaging photographic equipment to a support, said apparatus comprising:

- (a) a member defining a channel having a first side wall capable of lateral movement with respect to a second side wall;
- (b) a lever capable of causing said lateral movement and moveable between a first position and a second position and through an intermediate position;
- (c) a force generating member that capable of applying force to said first side wall and said lever where said

8

force increases when said lever is moved from said first position towards said intermediate position and said force increases when said lever is in said second position and is moved towards said intermediate position.

18. The apparatus of claim 17 where said force is at a maximum at said intermediate position.

19. The apparatus of claim 18 where said lever has a range of motion from said first position to said second position and said intermediate position is located between 50 percent and 90 percent of said range of motion.

20. The apparatus of claim 18 where said lever has a range of motion from said first position to said second position and said intermediate position is located between 60 percent and 90 percent of said range of motion.

21. The apparatus of claim 18 where said lever has a range of motion from said first position to said second position and said intermediate position is located between 70 percent and 90 percent of said range of motion.

22. The apparatus of claim 18 where said lever has a range of motion from said first position to said second position and said intermediate position is located between 80 percent and 90 percent of said range of motion.

23. An apparatus for engaging photographic equipment to a support, said apparatus comprising:

- (a) a member defining a channel having a first side wall capable of lateral movement with respect to a second side wall;
- (b) a lever capable of causing said lateral movement and moveable between a first position and a second position and through an intermediate position;
- (c) a force generating member capable of applying force to said first side wall and said lever, where said force increases when said lever is moved from said intermediate position towards said second position and said first side wall does not move with respect to said second side wall when said lever is moved from said intermediate position to said second position.

24. An apparatus for engaging photographic equipment to a support, said apparatus comprising:

- (a) a member defining a channel having a first side wall capable of travel with respect to a second side wall from a first location to a second location in response to actuation of an actuator, said first side wall capable of remaining in said second location without further actuation of said actuator;
- (b) said actuator being capable of causing said lateral movement by transmitting a force to said first side wall where said force increases over a major portion of said travel, said force varies over an interval from a first time to a second time while said second side wall remains in said second location, said force reaches a maximum value between said first time and said second time, and said force at said second time is greater than said force at said first time.

25. The apparatus of claim 24 where said actuator is a lever.

26. The apparatus of claim 25 where said lever is capable of movement between a first and a second position through an intermediate position, said first position is associated with said first location and said intermediate position through said second position is associated with said second location and said interval.

27. The apparatus of claim 24 where said force increases over at least 65% of said travel.

28. The apparatus of claim 24 where said force increases over all of said travel.

9

29. An apparatus for engaging photographic equipment to a support, said apparatus comprising:

- (a) a member defining a channel having a first side wall capable of lateral movement with respect to a second side wall;
- (b) a lever capable of causing said lateral movement and movable between a first position and a second position,

10

said lever engaged on a side of said member, said side defining opposed first and second corners; and
(c) a handle portion of said lever where said handle portion extends beyond said first corner when in said first position and extends beyond and around said second corner when in said second position.

* * * * *