



(12) **United States Patent**  
**Anthony et al.**

(10) **Patent No.:** US **6,738,249 B1**  
 (45) **Date of Patent:** \***May 18, 2004**

- (54) **UNIVERSAL ENERGY CONDITIONING INTERPOSER WITH CIRCUIT ARCHITECTURE**
- (75) Inventors: **Anthony A. Anthony**, Erie, PA (US);  
**William M. Anthony**, Erie, PA (US)
- (73) Assignee: **X2Y Attenuators, LLC**, Santa Monica, CA (US)
- (\* ) Notice: Subject to any disclaimer, the term of this patent is extended or adjusted under 35 U.S.C. 154(b) by 156 days.
- This patent is subject to a terminal disclaimer.

- (21) Appl. No.: **09/632,048**
- (22) Filed: **Aug. 3, 2000**

**Related U.S. Application Data**

- (63) Continuation of application No. 09/056,379, filed on Apr. 7, 1998, which is a continuation-in-part of application No. 09/594,447, filed on Jun. 15, 2000, which is a continuation-in-part of application No. 09/579,606, filed on May 26, 2000, which is a continuation-in-part of application No. 09/460,218, filed on Dec. 13, 1999, which is a continuation of application No. 09/056,379, filed on Apr. 7, 1998, now Pat. No. 6,018,448, which is a continuation-in-part of application No. 09/008,769, filed on Jan. 19, 1998, now Pat. No. 6,097,581, which is a continuation-in-part of application No. 08/841,940, filed on Apr. 8, 1997, now Pat. No. 5,909,350.
- (60) Provisional application No. 60/215,314, filed on Jun. 30, 2000, provisional application No. 60/203,863, filed on May 12, 2000, provisional application No. 60/200,327, filed on Apr. 28, 2000, provisional application No. 60/185,320, filed on Feb. 28, 2000, provisional application No. 60/191,196, filed on Mar. 22, 2000, provisional application No. 60/180,101, filed on Feb. 3, 2000, provisional application No. 60/165,035, filed on Nov. 12, 1999, and provisional application No. 60/146,987, filed on Aug. 3, 1999.
- (51) **Int. Cl.**<sup>7</sup> ..... **H02H 9/00**
- (52) **U.S. Cl.** ..... **361/117; 361/56; 361/111; 361/119**
- (58) **Field of Search** ..... **361/56, 111, 119, 361/127, 115, 117**

- (56) **References Cited**
- U.S. PATENT DOCUMENTS
- 3,842,374 A 10/1974 Schlicke  
 (List continued on next page.)
- FOREIGN PATENT DOCUMENTS
- DE 198 57 043 C1 3/2000  
 (List continued on next page.)
- OTHER PUBLICATIONS
- PCT International Search Report for International Application No. PCT/US/98/06962 Aug. 19, 1998.  
 (List continued on next page.)

*Primary Examiner*—Stephen W. Jackson  
*(74) Attorney, Agent, or Firm*—Hahn Loeser & Parks, LLP; Robert J. Clark

(57) **ABSTRACT**

The present invention relates to an interposer substrate for interconnecting between active electronic componentry such as but not limited to a single or multiple integrated circuit chips in either a single or a combination and elements that could comprise of a mounting substrate, substrate module, a printed circuit board, integrated circuit chips or other substrates containing conductive energy pathways that service an energy utilizing load and leading to and from an energy source. The interposer will also possess a multi-layer, universal multi-functional, common conductive shield structure with conductive pathways for energy and EMI conditioning and protection that also comprise a commonly shared and centrally positioned conductive pathway or electrode of the structure that can simultaneously shield and allow smooth energy interaction between grouped and energized conductive pathway electrodes containing a circuit architecture for energy conditioning as it relates to integrated circuit device packaging. The invention can be employed between an active electronic component and a multilayer circuit card. A method for making the interposer is not presented and can be varied to the individual or proprietary construction methodologies that exist or will be developed.

**73 Claims, 9 Drawing Sheets**

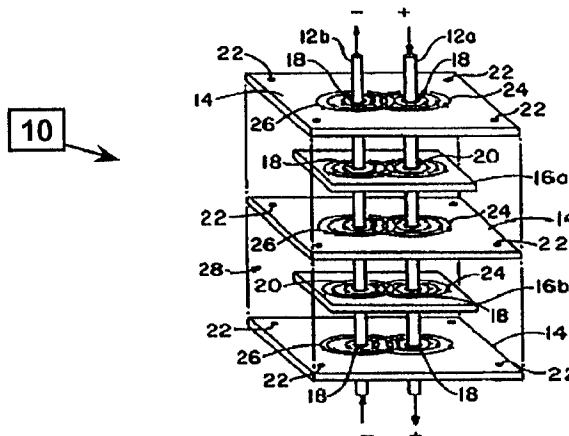

U.S. PATENT DOCUMENTS

4,262,317 A 4/1981 Baumbach  
 4,335,417 A 6/1982 Sakshaug et al.  
 4,587,589 A 5/1986 Marek  
 4,682,129 A 7/1987 Bakermans et al.  
 4,772,225 A 9/1988 Ulery  
 5,079,069 A 1/1992 Howard et al.  
 5,140,497 A 8/1992 Kato et al.  
 5,142,430 A 8/1992 Anthony  
 5,155,655 A 10/1992 Howard et al.  
 5,161,086 A 11/1992 Howard et al.  
 5,181,859 A 1/1993 Foreman et al.  
 5,236,376 A 8/1993 Cohen  
 5,243,308 A 9/1993 Shusterman et al.  
 5,251,092 A 10/1993 Brady et al.  
 5,261,153 A 11/1993 Lucas  
 5,268,810 A 12/1993 DiMarco et al.  
 5,290,191 A 3/1994 Foreman et al.  
 5,321,373 A 6/1994 Shusterman et al.  
 5,321,573 A 6/1994 Person et al .  
 5,337,028 A 8/1994 White  
 5,353,189 A 10/1994 Tomlinson  
 5,396,201 A 3/1995 Ishizaki et al.  
 5,414,587 A 5/1995 Kiser et al.  
 5,455,734 A 10/1995 Foreman et al.  
 5,483,407 A 1/1996 Anastasio et al.  
 5,500,629 A 3/1996 Meyer  
 5,512,196 A 4/1996 Mantese et al.  
 5,555,150 A 9/1996 Newman et al.  
 5,568,348 A 10/1996 Foreman et al.  
 5,592,391 A 1/1997 Muyschondt et al.  
 5,751,539 A 5/1998 Stevenson et al.  
 5,828,093 A 10/1998 Naito et al.  
 5,838,216 A 11/1998 White et al.  
 5,880,925 A 3/1999 DuPre et al.  
 5,889,445 A 3/1999 Ritter et al.  
 5,909,350 A \* 6/1999 Anthony ..... 361/118  
 6,018,448 A \* 2/2000 Anthony ..... 361/56  
 6,034,864 A 3/2000 Naito et al.

6,038,121 A 3/2000 Naito et al.  
 6,072,687 A 6/2000 Naito et al.  
 6,097,581 A 8/2000 Anthony

FOREIGN PATENT DOCUMENTS

JP 3-18112 1/1991  
 JP 6-53048 2/1994  
 JP 6-53049 2/1994  
 JP 6-53075 2/1994  
 JP 6-53077 2/1994  
 JP 6-53078 2/1994  
 JP 6-84695 3/1994  
 JP 6-151014 5/1994  
 JP 6-151244 5/1994  
 JP 6-151245 5/1994  
 JP 6-325977 11/1994  
 JP 7-235406 9/1995  
 JP 7-235852 9/1995  
 JP 7-240651 9/1995  
 JP 8-124795 5/1996  
 JP 8-172025 7/1996  
 JP 11-214256 8/1999  
 WO WO 00/16446 3/2000

OTHER PUBLICATIONS

PCT International Search Report for International Application No. PCT/US99/01040 Apr. 19, 1999.  
 PCT International Search Report for International Application No. PCT/US99/07653 Jul. 19, 1999.  
 PCT International Search Report for International Application No. PCT/US00/11409 Sep. 18, 2000.  
 PCT International Search Report for International Application No. PCT/US00/14626 Sep. 13, 2000.  
 PCT International Search Report for International Application No. PCT/US00/16518 Nov. 8, 2000.

\* cited by examiner

FIG. 1A

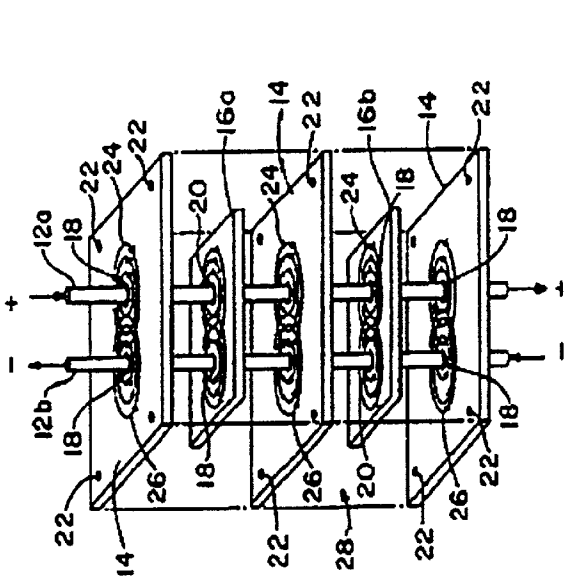

10

FIG. 1B

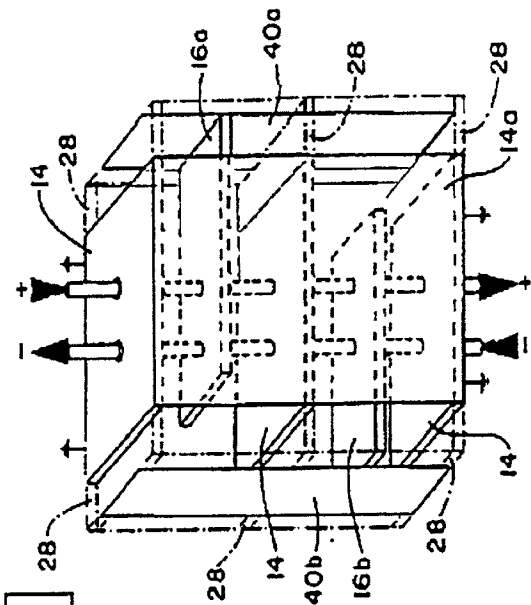

10

10

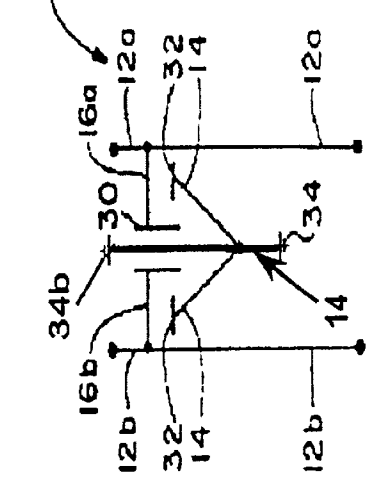

FIG. 2

FIG. 3

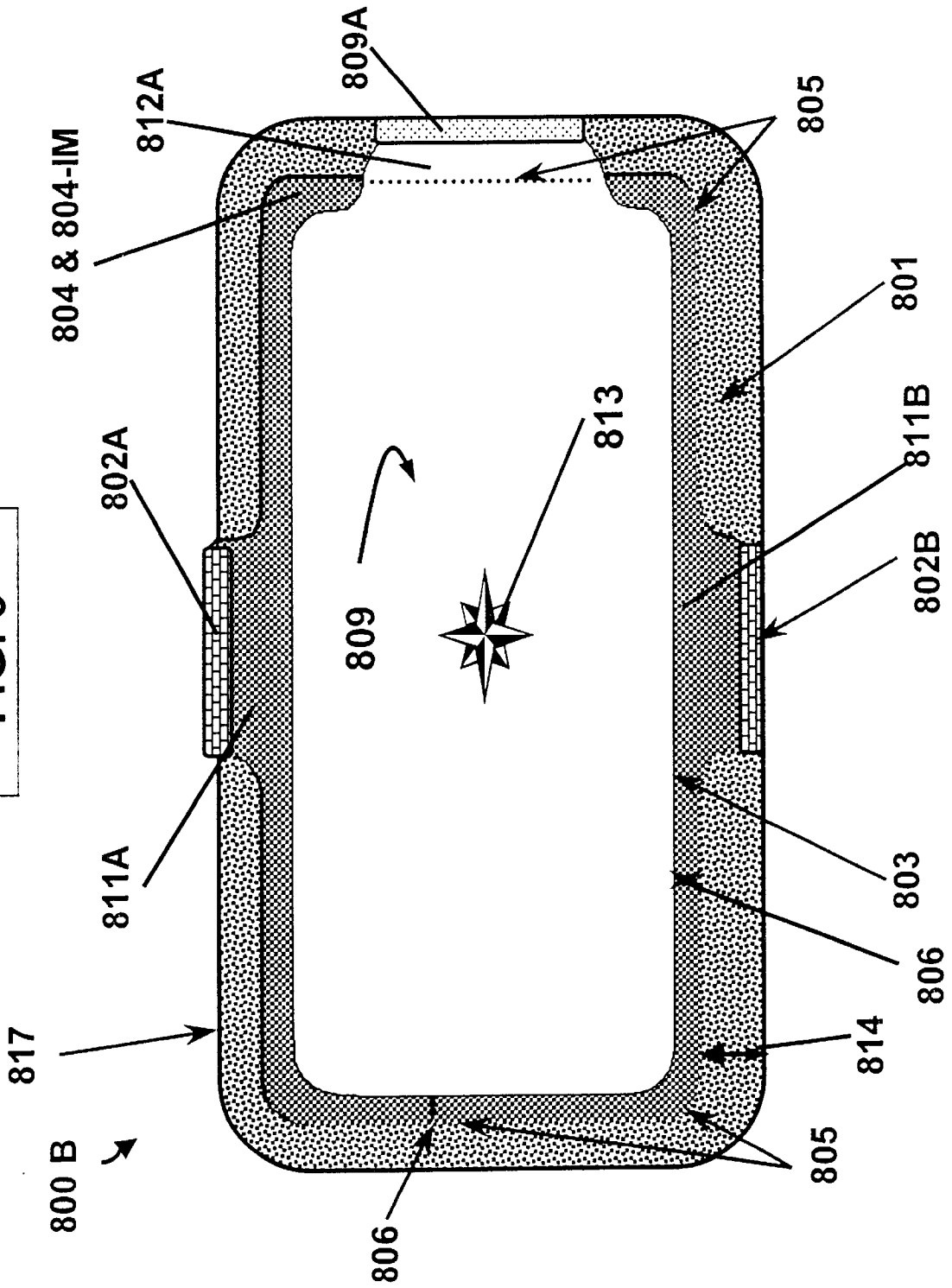

FIG. 4

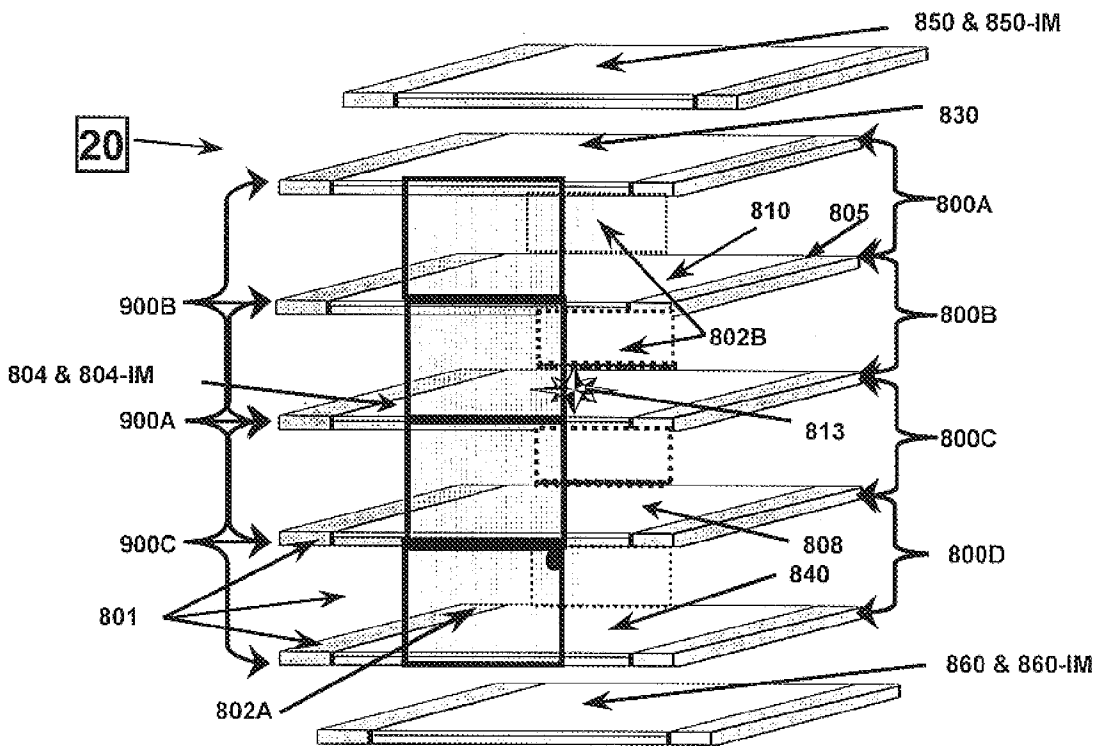

FIG. 5A

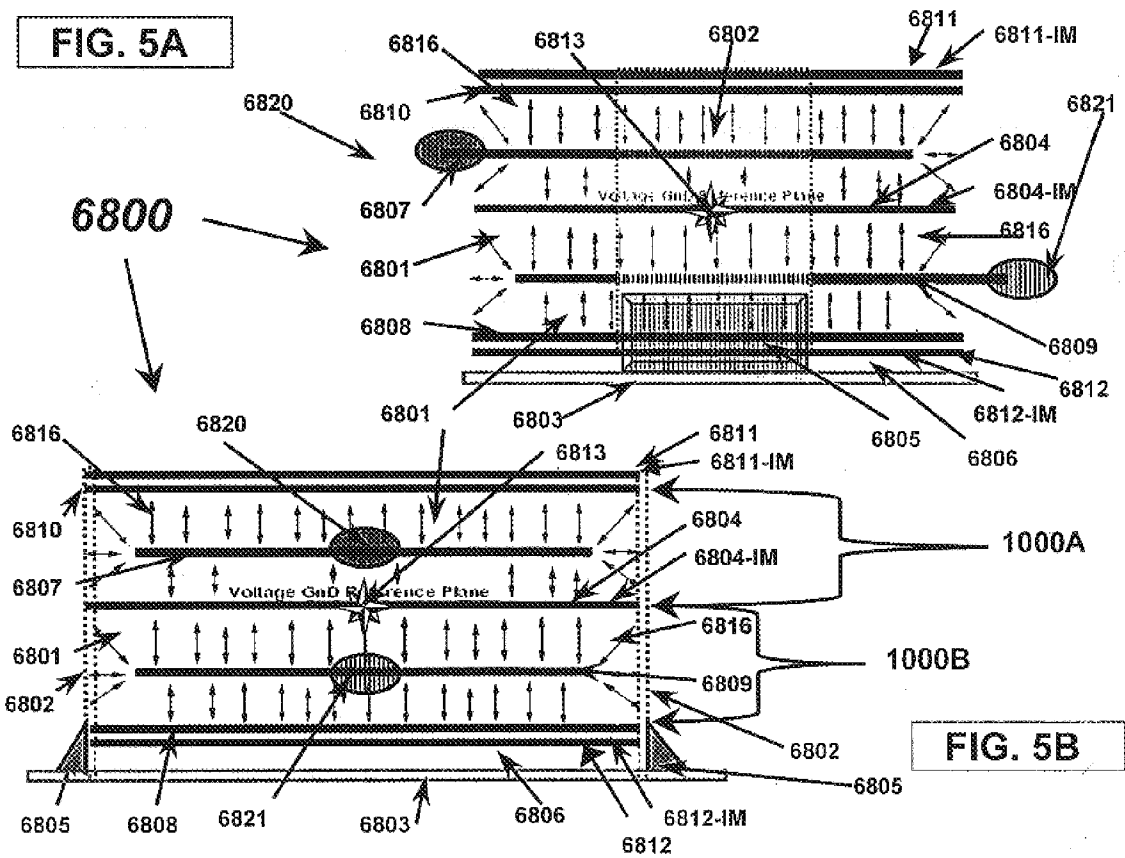

FIG. 5B

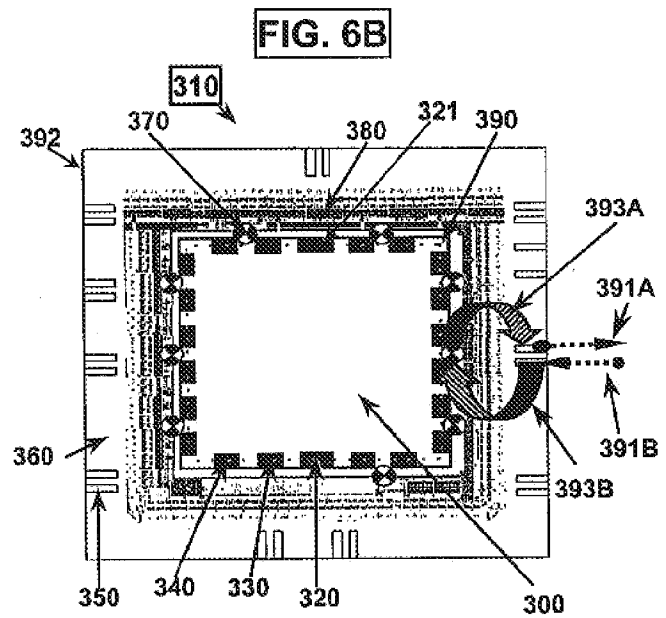
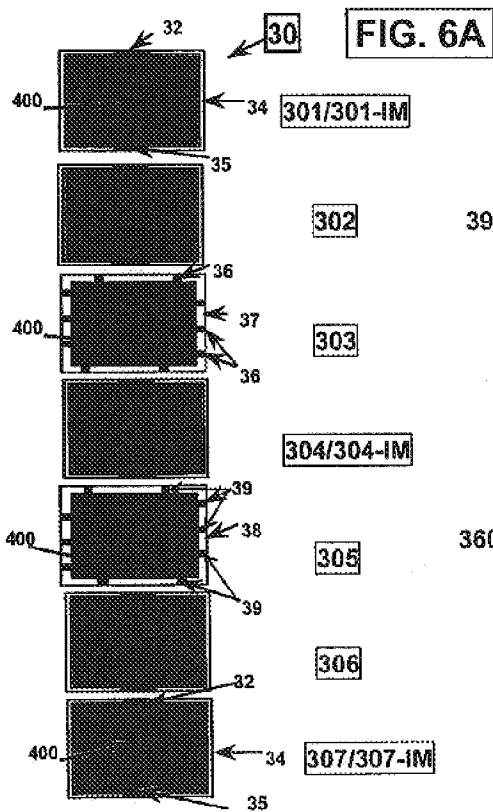
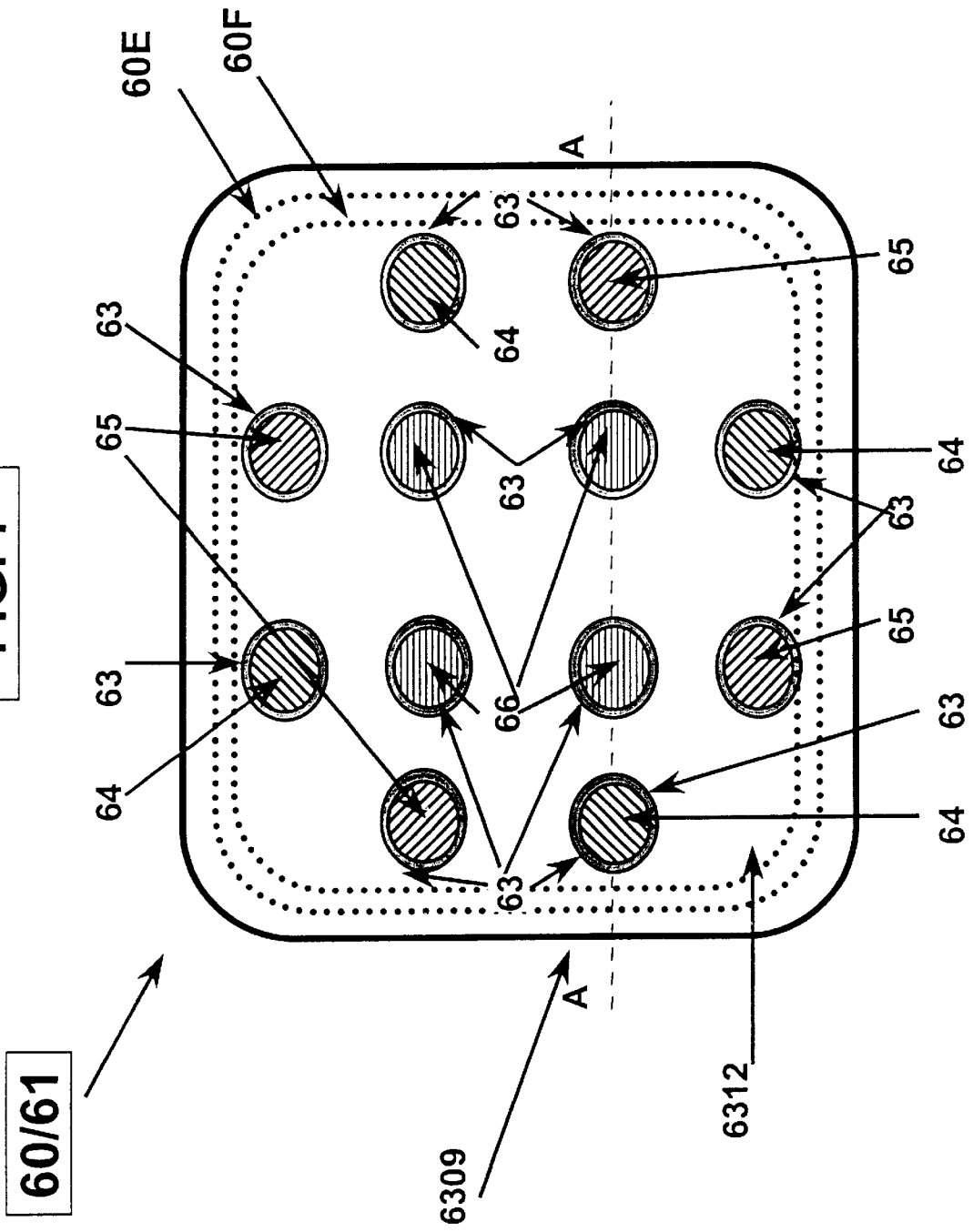

FIG. 7





**FIG. 8A**

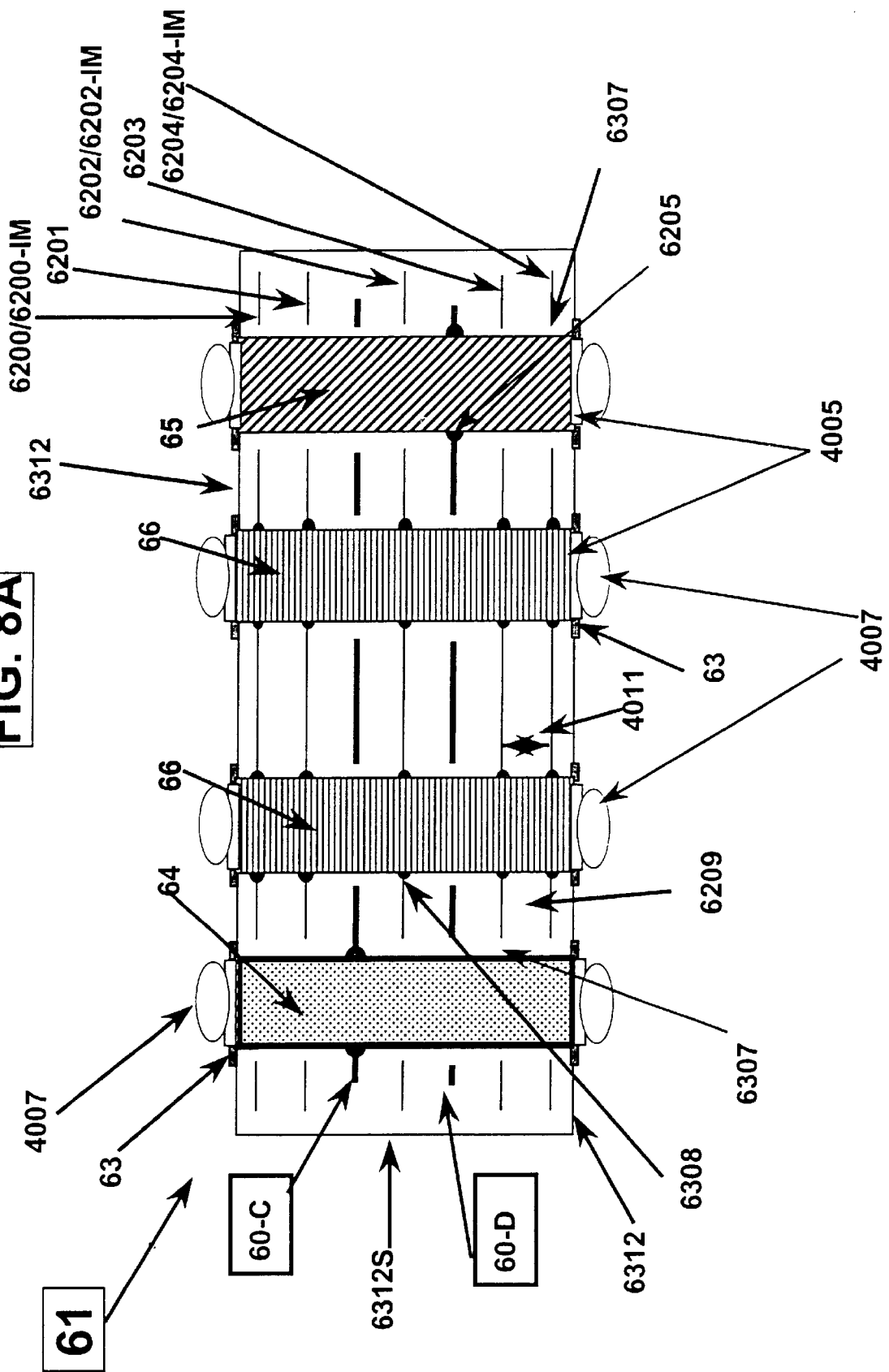
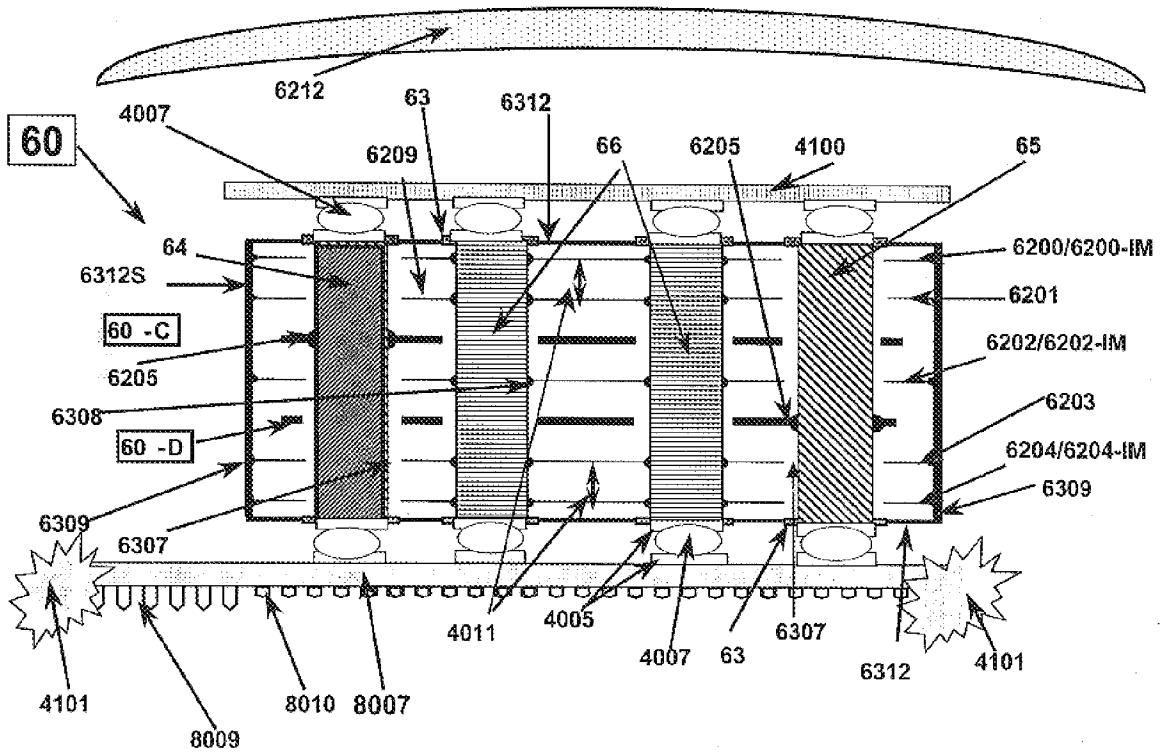
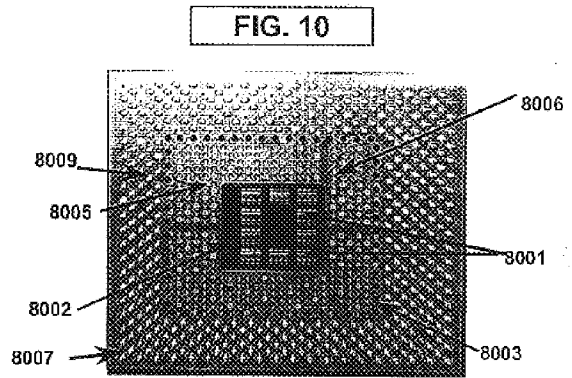
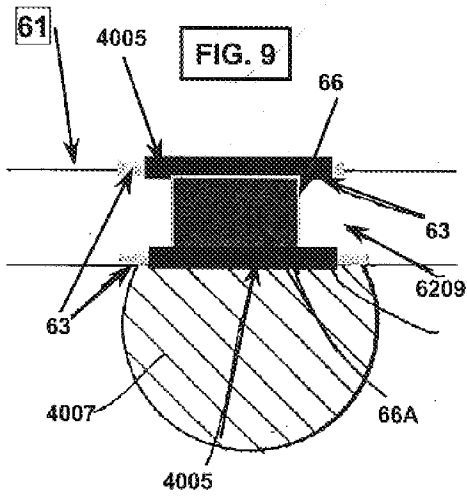

FIG. 8B





**UNIVERSAL ENERGY CONDITIONING  
INTERPOSER WITH CIRCUIT  
ARCHITECTURE**

This application is a continuation-in-part of co-pending application Ser. No. 09/056,379 filed Apr. 7, 1998, which is also a continuation-in-part of co-pending application Ser. No. 09/594,447 filed Jun. 15, 2000, which is a continuation-in-part of co-pending application Ser. No. 09/579,606 filed May 26, 2000, which is a continuation-in-part of co-pending application Ser. No. 09/460,218 filed Dec. 13, 1999, which is a continuation of application Ser. No. 09/056,379 filed Apr. 7, 1998, now issued as U.S. Pat. No. 6,018,448, which is a continuation-in-part of application Ser. No. 09/008,769 filed Jan. 19, 1998, now issued as U.S. Pat. No. 6,097,581, which is a continuation-in-part of application Ser. No. 08/841,940 filed Apr. 8, 1997, now issued as U.S. Pat. No. 5,909,350. This application also claims the benefit of U.S. Provisional Application No. 60/146,987 filed Aug. 3, 1999, U.S. Provisional Application No. 60/165,035 filed Nov. 12, 1999, U.S. Provisional Application No. 60/180,101 filed Feb. 3, 2000, U.S. Provisional Application No. 60/185,320 filed Feb. 28, 2000, U.S. Provisional Application No. 60/191,196 filed Mar. 22, 2000, U.S. Provisional Application No. 60/200,327 filed Apr. 28, 2000, U.S. Provisional Application No. 60/203,863 filed May 12, 2000, and U.S. Provisional Application No. 60/215,314 filed Jun. 30, 2000.

**TECHNICAL FIELD**

The present invention relates to a circuit interposer comprising a multilayer, universal, multi-functional, common conductive shield structure with conductive pathways for energy and EMI conditioning and protection that possesses a commonly shared and centrally positioned conductive pathway or electrode that simultaneously shields and allows smooth energy transfers such as decoupling operations between grouped and energized conductive pathways. The invention is for energy conditioning as it relates to integrated circuit (IC) device packaging or direct mounted IC modules, and more specifically, for interconnecting energy utilizing integrated circuit chips to a printed circuit board, (IC) device packaging or direct mounted IC modules as a interconnection medium between ICs and their component packaging and/or external energy circuit connections or other substrates containing energy pathways leading to and from an energy source and an energy utilizing load.

More specifically, the present invention allows paired or neighboring conductive pathways or electrodes to operate with respect to one another in a harmonious fashion, yet in an oppositely phased or charged manner, respectively. The invention will provide energy conditioning in such forms of EMI filtering and surge protection while maintaining apparent even or balanced voltage supply between a source and an energy utilizing-load when placed into a circuit and energized. The various embodiments of the invention will also be able to simultaneous and effectively provide energy conditioning functions that include bypassing, decoupling, energy storage, while maintaining a continued balance in SSO (Simultaneous Switching Operations) states without contributing disruptive energy parasitics back into the circuit system as the invention is passively operated within the circuit.

**BACKGROUND OF THE INVENTION**

Interposer structures can be used in the manufacturing process of single and multi-chip modules (SCMs or MCMs)

to electrically connect one or more integrated circuit chips (ICs) to a printed circuit board, discreet IC electronic packaging, or other substrates. The interposer provides conditioning of various forms of energy propagating along the contained internal interposer conductive pathways located between an energy source and an energy-utilizing load such as an IC. The interposer can provide energy paths between the IC chips and a PC board or substrate, and if desired, between different active component chips mounted on the interposer, itself.

A main disadvantage of conventional approaches to interconnecting and packaging of IC chips in Multi Chip Modules (MCMs) arises from the thinness of the substrates used in traditional multichip modules results in the energy feeds to the IC chips having relatively high impedance. This results in undesired noise, energy loss and excess thermal energy production. These problems are relevant and can be critical to system integrity when routing or propagating energy along pathways though an interposer substrate.

Electrical systems have undergone short product life cycles over the last decade. A system built just two years ago can be considered obsolete to a third or fourth generation variation of the same application. Accordingly, passive electronic components and the circuitry built into these the systems need to evolve just as quickly. However, the evolution of passive electronic componentry has not kept pace. The performance of a computer or other electronic systems has typically been constrained by the operating frequency of its slowest active elements. Until recently, those elements were the microprocessor and the memory components that controlled the overall system's specific functions and calculations. Nevertheless, with the advent of new generations of microprocessors, memory components and their data, the focus has changed. There is intense pressure upon the industry to provide the system user with increased processing energy and speed at a decreasing unit cost. EMI created in these environments must also be eliminated or minimized to meet international emission and/or susceptibility requirements.

Processor operating frequency (speed) is now matched by the development and deployment of ultra-fast RAM (Random Access Memory) architectures. These breakthroughs have allowed an increase of the overall system—operating frequency (speed) of the active components past the 1 GHz mark. During this same period, however, passive component technologies have failed to keep up with these new breakthroughs and have produced only incremental changes in composition and performance. These advances in passive component design and changes have focused primarily upon component size reduction, slight modifications of discrete component electrode layering, dielectric discoveries, and modifications of device manufacturing techniques or rates of production that decrease unit production cycle times.

In addition, at these higher frequencies, energy pathways should normally be grouped or paired as an electrically complementary element or elements that work together electrically and magnetically in harmony and in balance within an energized system. Attempts to line condition propagating energy with prior art components has led to increased levels of interference in the form of EMI, RFI, and capacitive and inductive parasitics. These increases are due in part to manufacturing imbalances and performance deficiencies of the passive components that create or induce interference into the associated electrical circuitry.

These problems have created a new industry focus on passive components whereas, only a few years ago, the

focus was primarily on the interference created by the active components from sources and conditions such as voltage imbalances located on both sides of a common reference or ground path, spurious voltage transients from energy surges or human beings, or other electromagnetic wave generators.

At higher operating speeds, EMI can also be generated from the electrical circuit pathway itself, which makes shielding from EMI desirable. Differential and common mode noise energy can be generated and will traverse along and around cables, circuit board tracks or traces, and along almost any high-speed transmission line or bus line pathway. In many cases, one or more of these critical energy conductors can act as an antenna, hence creating energy fields that radiate from these conductors and aggravate the problem even more. Other sources of EMI interference are generated from the active silicon components as they operate or switch. These problems such as SSO are notorious causes of circuit disruptions. Other problems include unshielded and parasitic energy that freely couples upon or onto the electrical circuitry and generates significant interference at high frequencies.

U.S. patent application Ser. No. 09/561,283 filed on Apr. 28, 2000 and U.S. patent application Ser. No. 09/579,606 filed on May 26, 2000, and U.S. patent application Ser. No. 09/594,447 filed on Jun. 15, 2000 along with U.S. Provisional Application No. 60/200,327 filed Apr. 28, 2000, U.S. Provisional Application No. 60/203,863 filed May 12, 2000, and U.S. Provisional Application No. 60/215,314 filed Jun. 30, 2000 by the applicants relate to continued improvements to a family of discrete, multi-functional energy conditioners. These multi-functional energy conditioners possess a commonly shared, centrally located, conductive electrode of a structure that can simultaneously interact with energized and paired conductive pathway electrodes contained in energy-carrying conductive pathways. These energy-carrying conductive pathways can operate in an oppositely phased or charged manner with respect to each other and are separated from one another by a physical shielding.

#### SUMMARY OF THE INVENTION

Based upon the foregoing, there has been found a need to provide a manufactured interposed circuit connection device that uses a layered, multi-functional, common conductive shield structure containing energy-conductive pathways that share a common and centrally positioned conductive pathway or electrode as part of its structure which allows for energy conditioning as well as a multitude of other functions simultaneously in one complete unit.

The invention will also comprise at least one inclusive embodiment or embodiment variation that possesses a commonly shared and centrally positioned conductive pathway or electrode as part of its structure.

The invention will also provide for simultaneous physical and electrical shielding to portions of an active chip structure as well as for internal propagating energies within the new structure by allowing predetermined, simultaneous energy interactions to take place between grouped and energized conductive pathways to be fed by pathways external to the embodiment elements.

This application expands upon this concept and further discloses a new circuit interposer comprising a multilayer, universal multi-functional, common conductive shield structure with conductive pathways that replaces multiple, discrete versions of various prior art devices with a single individual unit that provides a cost effective system of circuit protection and conditioning that will help solve or reduce industry problems and obstacles as described above.

Accordingly, the solution to low impedance energy distribution above several hundred MHz lies in thin dielectric energy plane technology, in accordance with the present invention, which is much more effective than multiple, discrete decoupling capacitors.

It is an object of the invention to be able to provide energy decoupling for active system loads while simultaneously maintaining a constant, apparent voltage potential for that same portion of active components and its circuitry.

It is an object of the invention to minimize or suppress unwanted electromagnetic emissions resulting from differential and common mode currents flowing within electronic pathways that come under the invention influence.

It is an object of the invention to provide a wide variety of multi-layered embodiments and utilize a host of dielectric materials, unlimited by their specific physical properties that can, when attached into circuitry and energized, provide simultaneous line conditioning functions and protections as will be described.

It is an object of the invention to provide the ability to the user to solve problems or limitations not met with prior art devices which include, but are not limited to, simultaneous source to load and/or load to source decoupling, differential mode and common mode EMI filtering, containment and exclusion of certain energies such as capacitive and inductive parasitics, as well as parasitic containment and surge protection in one integrated embodiment and that performs these described abilities when utilizing a conductive area or pathway.

It is an object of the invention to be easily adapted to utilization with or without, one or more external conductive attachments to a conductive area located external to the originally manufactured invention. The external connection to a conductive area—can aid the invention embodiments in providing protection to electronic system circuitry.

It is an object of the invention to provide a physically integrated, shield-containment, conductive electrode architecture for the use with independent electrode materials and/or an independent dielectric material composition, that when manufactured, will not limit the invention to a specific form, shape, or size for the multitude of possible embodiments of the invention that can be created and is not limited to embodiments shown herein.

It is another object of the invention to provide a constant apparent voltage potential for portions of circuitry.

It is another object of the invention to provide an embodiment that utilizes standard manufacturing processes and be constructed of commonly found dielectric and conductive materials or conductively made materials to reach tight capacitive, inductive and resistive tolerances between or along electrical pathways within the embodiment, while simultaneously maintaining a constant and uninterrupted conductive pathway for energy propagating from a source to an energy utilizing load.

It is another object of this invention to provide a means of lowering circuit impedance by providing and maintaining conductive pathways that are essentially in parallel within the interposer to the energy source and the energy-utilizing load when attached into circuitry between these their energy conduits and to a circuit reference node or ground as a low circuit impedance pathway.

Lastly, it is an object of the invention to provide an embodiment that couples pairs or groups of paired electrical pathways or conductors very closely in relation to one another into an area or space partially enveloped by a

plurality of commonly joined conductive electrodes, plates, or pathways, and can provide a user with a choice of selectively coupling external conductors or pathways on to separate or common conductive pathways or electrode plates located within the same embodiment.

Numerous other arrangements and configurations are also disclosed which implement and build upon the above objects and advantages of the invention in order to demonstrate the versatility and wide spread application of a universal energy conditioning interposer with circuit architecture for energy and EMI conditioning and protection within the scope of the present invention.

#### BRIEF DESCRIPTION OF THE DRAWINGS

FIG. 1A shows an exploded perspective view of an embodiment from family multi-functional energy conditioners;

FIG. 1B shows an exploded perspective view of an alternate embodiment from the family multi-functional energy conditioners shown in FIG. 1A;

FIG. 2 provides a circuit schematic representation of the physical architecture from FIG. 1A and FIG. 1B when placed into a larger electrical system and energized;

FIG. 3 shows a top view of a portion of some of the non-holed embodiment elements comprising a portion of a Faraday cage-like conductive shield structure and a by-pass conductive pathway electrode;

FIG. 4 shows an exploded perspective view of a portion the non-holed embodiment elements that form a Faraday cage-like conductive shield structure that comprises a non-holed, interconnected, parallel, common conductive shield structure;

FIG. 5A shows an exploded cross-section view of a non-holed, multi-layered by-pass arrangement of the circuit architecture used in present invention configurations with outer image shields;

FIG. 5B shows a second exploded cross-sectional view of a layered by-pass as shown in FIG. 5A and rotated 90 degrees there from;

FIG. 6A shows an exploded view of a layered arrangement of an embodiment of the present invention with outer image shields;

FIG. 6B shows a partial view of the interposer arrangement depicted in FIG. 6A mounted above an Integrated Circuit Die placed into a portion of an Integrated Circuit Package that uses wireleads or pin interconnection instead of ball grid interconnections;

FIG. 7 shows a top view of an interposer arrangement;

FIG. 8A shows a cross-sectional view of an alternate interposer arrangement depicted in FIG. 7;

FIG. 8B shows a partial cross-sectional view of the interposer arrangement depicted in FIG. 7 now mounted in between an Integrated Circuit Die Integrated Circuit Package with ball grid interconnection is shown;

FIG. 9 shows a close-up view of a solder ball interconnection of FIG. 8A;

FIG. 10 shows a partial top external view of an Integrated Circuit Package showing the outline of a prior art interposer with externally mounted, discrete arrays used to assist energy conditioning;

FIG. 11 shows a partial top external view of an Integrated Circuit Package similarly depicted in FIG. 10 but with out the prior art interposer but the new invention placed between an Integrated Circuit Die Integrated Circuit Package with ball grid interconnection is shown.

#### DETAILED DESCRIPTION OF THE PREFERRED EMBODIMENT

As used herein, the acronym terms "UECICA" will be used to mean a universal energy conditioning interposer with circuit architecture for energy and EMI conditioning and protection within the scope of the present invention and refers to all types of discrete versions of the device.

In addition, as used herein, the acronym term "AOC" for the words "predetermined area or space of physical convergence or junction" which is defined as the physical boundary of manufactured-together invention elements. Non-energization and energization are defined as the range or degree to which electrons within the "AOC" of either discrete or non-discrete versions of UECICA are in motion and are propagating to and/or from an area located outside the pre-determined in a balanced manner.

U.S. Pat. No. 6,018,448, which is a continuation-in-part of application Ser. No. 09/008,769 filed Jan. 19, 1998, now issued as U.S. Pat. No. 6,097,581, which is a continuation-in-part of application Ser. No. 08/841,940 filed Apr. 8, 1997, now issued as U.S. Pat. No. 5,909,350 and U.S. patent application Ser. No. 09/561,283 filed on Apr. 28, 2000, U.S. patent application Ser. No. 09/579,606 filed on May 26, 2000, and U.S. patent application Ser. No. 09/594,447 filed on Jun. 15, 2000 along with U.S. Provisional Application No. 60/215,314 filed Jun. 30, 2000 by the applicants relate to continued improvements to a family of discrete, multi-functional energy conditioners and multi-functional energy conditioning shield structures and are incorporated by reference, herein.

The new UECICA begins as a combination of electrically conductive, electrically semi-conductive, and non-conductive dielectric independent materials, layered or stacked in various structures. These layers can be combined to form a unique circuit when placed and energized in a system. The invention embodiments can include layers of electrically conductive, electrically semi-conductive, and non-conductive materials that form groups of common conductive pathway electrodes, differentially phased conductors, deposits, plates, VIAs, filled and unfilled conductive apertures that can all be referred to at one time or another, herein as meaning energy conductive pathway. Herein, the term "common conductive", means the same species of energy pathway that may all be joined together in one conductive structure as a common energy pathway of low impedance as opposed to a differential conductive pathway that is usually written as with respect to another pathway that is paired up with the same in an energized circuit that would have an electrically opposite pathway functioning electromagnetically, in most cases, 180 degrees opposite our out of phase with its counterpart.

Dielectric, non-conductive and semi-conductive mediums or materials can also be referred to as simply insulators, non-pathways or simply dielectric. Some of these elements are oriented in a generally parallel relationship with respect to one another and to a predetermined pairing or groups of similar elements that can also include various combinations of conductive pathways and their layering made into a predetermined or manufactured structure. Other elements of the invention can be oriented in a generally parallel relationship with respect to one another and yet will be in a generally perpendicular relationship with other elements of the same invention.

Predetermined arrangements are used in manufacturing the invention to combine many of the elements just described such as dielectric layers, multiple electrode con-

ductive pathways, sheets, laminates, deposits, multiple common conductive pathways, shields, sheets, laminates, or deposits, together in an interweaved arrangement of overlapping, partially overlapping and non-overlapping positions with respect to other physical structures with in the invention made up identically of the same materials yet are effected by a predetermined configuration sequence of the end manufactured result that connects specific types of these same elements such as VIAs, dielectric layers, multiple electrode conductive pathways, sheets, laminates, deposits, multiple common conductive pathways, shields, sheets, laminates, or deposits, together for final energizing into a larger electrical system in a predetermined manner.

Other conductive energy pathways can intersect and pass through the various layers just described and can be in a generally non-parallel or even perpendicular relationship with respect to these same groups of layers. Conductive and nonconductive spacers can be attached to the various groups of layers and intersecting, perpendicular pathways in a predetermined manner that allows various degrees and functions of energy conditioning to occur with portions of propagating energy passing into and out of the invention AOC.

As for all embodiments of the present invention depicted and those not pictured, the applicants contemplate a manufacturer to have the option in some cases, for combining a variety and wide range of possible materials that are selected and combined into the final make-up of the invention while still maintaining some or nearly all of the desired degrees of electrical conditioning functions of the invention after it is manufactured and placed into a circuit and energized. Materials for composition of the invention can comprise one or more layers of material elements compatible with available processing technology and is not limited to any possible dielectric material. These materials may be a semiconductor material such as silicon, germanium, gallium-arsenide, or a semi-insulating or insulating material and the like such as, but not limited to any material having a specific dielectric constant, K.

Equally so, the invention is not limited: to any possible conductive material such as magnetic, nickel-based materials, MOV-type material, ferrite material;—any substances and processes that can create conductive pathways for a conductive material such as Mylar films or printed circuit board materials; or any substances or processes that can create conductive areas such as, but not limited to, doped polysilicons, sintered polycrystallines, metals, or polysilicon silicates, polysilicon silicide. When or after the structured layer arrangement is manufactured as an interposer it is not limited to just IC packages, it can be combined with, shaped, buried within or embedded, enveloped, or inserted into various electrical packaging, other substrates, boards, electrical arrangements, electrical systems or other electrical sub-systems to perform simultaneous energy conditioning, decoupling, so to aid in modifying an electrical transmission of energy into a desired electrical form or electrical shape.

An alternative embodiment can serve as a possible system or subsystem electrical platform that contains both active and passive components along with additional circuitry, layered to provide most of the benefits described for conditioning propagated energy from a source to a load and back to a return. Some prior art interposers are already utilizing predetermined layered configurations with VIAs to service or tap the various conductive pathways or layers that lie between a dielectric or an insulating material.

The invention will also comprise at least one inclusive embodiment or embodiment variation that possesses a com-

monly shared and centrally positioned conductive pathway or electrode as part of its structure.

The invention will also provide for simultaneous physical and electrical shielding to portions an active chip structure as well as for internally propagating energies within the new structure by allowing predetermined, simultaneous energy interactions to take place between grouped and energized—conductive pathways to be fed by pathways external to the embodiment elements.

Existing prior art discrete decoupling capacitors lose their effectiveness at about 500 MHz. For example, mounting inductance for 0603 size capacitors has been reduced to approximately 300 pH. Assuming 200 pH for the internal capacitance of the capacitors, this equates to a total of 500 pH, which corresponds to 1.57-Ohms at 500 MHz. Accordingly, current discrete capacitors are not effective. While it is possible to use multiple components that have various values of series resonant frequencies and low ESR capacitors to drive towards low impedance at 500 MHz, the capacitance required to obtain 500 MHz with 500 pH ESL is about 200 pF. Current board materials (FR-4, 4 mils dielectric)—get 225 pF for every square inch of energy planes, which would require more than one discrete capacitor every square inch. Normally, various interposers that contain multiple discrete passive component structures offer into the circuitry a lack of electrical balance that in turn creates additional discontinuities with their presence in the energized circuit system.

A superior approach when utilizing various interconnection platforms and methodologies for direct IC chip attachment configurations to a PCB or other package connections is to provide low impedance from the energy pathways or electrode planes using a single embodiment. It is impractical to utilize many discrete, low impedance-decoupling capacitors on an interposer or PCB, if low impedance energy planes are not available to hook them up.

This application expands upon this concept and further discloses a new circuit interposer comprising a multi-layer, universal multi-functional, common conductive shield structure with conductive pathways that replaces multiple, discrete versions of various prior art components with a single individual unit that provides a cost effective, single component embodiment variations of what the applicants believe to be a new universal system of circuit protection and conditioning that will help solve or reduce industry problems and obstacles as described above with simplicity and an exponential effectiveness.

Accordingly, the solution to low impedance energy distribution above several hundred MHz lies in thin dielectric energy plane technology, in accordance with the present invention, which is much more effective than multiple, discrete decoupling capacitors.

Therefore, it is also an object of the invention to be able to operate effectively across a broad frequency range as compared to a single discrete capacitor component or a multiple passive conditioning network while maintaining a complete energy delivery protocol to a single or multiple units of active components utilizing portions of propagating energy within a circuit. Ideally, this invention can be universal in its application potentials, and by utilizing various embodiments of predetermined grouped elements, a working invention will continue to perform effectively within a system operating beyond 1 GHz of frequency.

To propagate electromagnetic interference energy, two fields are required, an electric field and a magnetic field. Electric fields couple energy into circuits through the volt-

age differential between two or more points. Changing electrical fields in a space give rise to a magnetic field. Any time-varying magnetic flux will give rise to an electric field. As a result, a purely electric or purely magnetic time-varying field cannot exist independent of each other. Maxwell's first equation is known as the divergence theorem based on Gauss's law. This equation applies to the accumulation of an electric charge that creates an electrostatic field, ("E-Field") and is best observed between two boundaries, conductive and nonconductive. This boundary condition behavior referenced in Gauss's law causes a conductive enclosure (also called a Faraday cage) to act as an electrostatic shield.

At a pre-determined boundary or edge, electric charges can be kept on the inside of the internally located conductive boundary of a pathway of the invention as a result of pre-determined design actions taken when the invention was built, specific manufacturing methodologies and techniques described herein account for the end product performance when placed into a circuit and energized.

Electric charges that exist outside a pre-determined boundary or edge of the internal conductive boundary of a pathway inside the invention are also excluded from effecting the very same internally generated fields trying to leave the same conductive pathways.

Maxwell's second equation illustrates that there are no magnetic charges (no monopoles), only electric charges. Electric charges are either positively charged or negatively charged. Magnetic fields are produced through the action of electric currents and fields. Electric currents and fields ("E-Field") emanate as a point source. Magnetic fields form closed loops around the current that generates fields located on along the energized conductive pathways. Maxwell's third equation, also called Faraday's Law of Induction, describes a magnetic field (H-Field) traveling in a closed loop circuit, generating current. The third equation describes the creation of electric fields from changing magnetic fields. Magnetic fields are commonly found in transformers or windings, such as electric motors, generators, and the like. Together Maxwell's third & fourth equations describe how coupled electric and magnetic fields propagate (radiate) at the speed of light. This equation also describes the concept of "skin effect," which predicts the effectiveness of magnetic shielding and can even predict the effectiveness of non-magnetic shielding.

There are two kinds of grounds normally found in today's electronics: earth-ground and circuit ground. The earth is not an equipotential surface, so earth ground potential can vary. Additionally, the earth has other electrical properties that are not conducive to its use as a return conductor in a circuit. However, circuits are often connected to earth ground for protection against shock hazards. The other kind of ground or common conductive pathway, circuit common conductive pathway, is an arbitrarily selected reference node in a circuit—the node with respect to which other node voltages in the circuit are measured. All common conductive pathway points in the circuit do not have to go to an external grounded trace on a PCB, Carrier or IC Package, but can be taken directly to the internal common conductive pathways. This leaves each current loop in the circuit free to complete itself in whatever configuration yields minimum path of least impedance for portions of energy effected in the AOC of the new invention. It can work for frequencies wherein the path of least impedance is primarily inductive.

With respect to grounding as just described above, there are at least three shielding functions that occur within the invention. First, a physical shielding of differential conduc-

tive pathways accomplished by the size of the common conductive pathways in relationship to the size of the differentially conductive pathways and by the energized, electrostatic suppression or minimization of parasitics originating from the sandwiched differential conductors as well as preventing external parasitics not original to the contained differential pathways from conversely attempting to couple on to the shielded differential pathways, sometimes referred to among others as capacitive coupling. Capacitive coupling is known as electric field ("E") coupling and this shielding function amounts to primarily shielding electrostatically against electric field parasitics. Capacitive coupling involving the passage of interfering propagating energies because of mutual or stray capacitances that originate from the differential conductor pathways is suppressed within the new invention. The invention blocks capacitive coupling by almost completely enveloping the oppositely phased conductors within Faraday cage-like conductive shield structures ("FCLS") that provide an electrostatic or Faraday shield effect and with the positioning of the layering and pre-determined layering position both vertically and horizontally (inter-mingling).

In other prior art devices, if shield coverage is not 100%, the shield structure is usually grounded to ensure that circuit-to-shield capacitances go to propagating energy reference common conductive pathway rather than act as feedback and cross-talk elements. However, the present invention can use an internal propagating energy reference common conductive pathway or an image ground within the device for this. The device's FCLS are used to suppress and prevent internal and external (with respect to the AOC) capacitive coupling between a potentially noisy conductor and a victim conductor, by an imposition of common conductive pathway layers positioned between each differential conductive pathway conductors any stray capacitance.

Secondly, a conductor positioning shielding technique which is used against inductive energy coupling and is also known as mutual inductive cancellation or minimization of portions of energy propagating along separate and opposing conductive pathways.

Finally, a physical shielding function for RF noise. Inductive coupling is magnetic field ("H") coupling, so this shielding function amounts to shielding against magnetic shields and this shielding occurs with in the device through mutual cancellation or minimization. RF shielding is the classical "metallic barrier" against all sorts of electromagnetic fields and is what most people believe shielding is about. There are two aspects to defending a circuit against inductive pickup. One aspect is to try to minimize the offensive fields at their source. This is done by minimizing the area of the current loop at the source so as to promote field cancellation or minimization, as described in the section on current loops. The other aspect is to minimize the inductive pickup in the victim circuit by minimizing the area of that current loop, since, from Lenz's law; the induced voltage is proportional to this area. So the two aspects really involve the same cooperative action: minimize the areas of the current loops. In other words, minimizing the offensiveness of a circuit inherently minimizes its susceptibility. Shielding against inductive coupling means nothing more than controlling the dimensions of the current loops in the circuit. The RF current in the circuit directly relates to signal and energy distribution networks along with bypassing and decoupling.

RF currents are ultimately generated as harmonics of clock and other digital signals. Signal and propagating energy distribution networks must be as small as possible to



minimize the loop area for the RF return currents. Bypassing and decoupling relate to the current draw that must occur through a propagating energy distribution network, which has by definition, a large loop area for RF return currents. In addition, it also relates to the loop areas that must be reduced, electric fields that are created by improperly contained transmission lines and excessive drive voltage.

The best way to minimize loop areas when many current loops are involved is to use a common conductive pathway. The idea behind RF shielding is that time-varying EMI fields induce currents in the shielding material. The freedom to use any material and dielectric in the construction of the assembly allows this constraint to be overcome. More formally, losses commonly referred to as absorption loss, re-radiation losses, or reflection loss, can be more controlled.

A common conductive pathway is a conducting surface that is to serve as a return conductor for all the current loops in the circuit. The invention uses its common conductive shields as an separate internal common conductive pathway located between but sandwiching the non-aperture using conductors to provide a physically tight or minimized energy loop between the interposer and the active chip that the energy is being condition for. A hole-thru, common conductive pathway-possessing structure works as well as a non-hole element of the assembly as far as for minimizing loop area is concerned. The key to attaining minimum loop areas for all the current loops together is to let the common conductive pathway currents distribute themselves around the entire area of the component's common conductive pathway area elements as freely as possible.

By surrounding predetermined conductive pathway electrodes with cage-like structures made up with one centralized and shared, common conductive pathway or area, this common pathway or area becomes a 0-reference common conductive pathway for circuit voltages and exists between at least two oppositely phased or voltage potential conductive structures which in turn are located each respectively on opposite sides of the just described sandwiched centralized and shared, common conductive pathway or area.

The addition of two additional common conductive pathways can be added to the previously disclosed five common conductive pathways into an electrically common structure that now almost completely envelopes the two differentially energized pathways as just described is a type of configuration that significantly completes the energized functions of suppressing or minimizing E-Fields and H-fields, stray capacitances, stray inductances, parasitics, and allowing for mutual cancellation or minimization of oppositely charged or phased, adjoining or abutting, electrical fields of the variously positioned propagating energy pathways. In the last step for the horizontal layering process of a 7-layer interposer, two additional common pathways sandwich the first 5-layers as previously described. A SCM or MCM, for example, built with the invention can take advantage of the various third conductive pathways common to one another or to the grounding, schemes used now by large SCM and MCM manufacturers.

In the invention, the feed path for portions of propagating energy and the return path for similar portions of propagating energy with in the invention are separated by microns of distance and normally by only by a common conductive pathway and some predetermined dielectric. Such a configuration allows for suppression or minimization and minimizes or cancels the portions of circuit energy that exists in the magnetic field and that is produced by this very tiny current loop. Maintaining a very effective mutual cancella-

tion or minimization of inductance of opposing but shielded differential conductive pathways will effect the minimal magnetic flux remaining and means minimal susceptibility to inductive coupling, anywhere internally of the inventions elements.

The new invention mimics the functionality of an electrostatically shielded, transformer. Transformers are also widely used to provide common mode (CM) isolation. These devices depend on a differential mode transfer (DM) across their input to magnetically link the primary windings to the secondary windings in their attempt to transfer energy. As a result, CM voltage across the primary winding is rejected. One flaw that is inherent in the manufacturing of transformers is propagating energy source capacitance between the primary and secondary windings. As the frequency of the circuit increases, so does capacitive coupling; circuit isolation is now compromised. If enough parasitic capacitance exists, high frequency RF energy (fast transients, ESD, lighting, etc.) may pass through the transformer and cause an upset in the circuits on the other side of the isolation gap that received this transient event. Depending on the type and application of the transformer, a shield may be provided between the primary and secondary windings. This shield, connected to a common conductive pathway reference source, is designed to prevent against capacitive coupling between the two sets of windings.

The new invention also resembles in energy transfer or energy propagation the workings of a transformer and the new device effectively uses not just a physical shield to suppress parasitics and such, it also uses positioning of its layering, connections of the layering, and the external combination with an external circuitry, to effectively function in a novel and unexpected way.

If a system is being upset by AC line transients, this type of function will provide the fix. In prior art devices, to be effective in this type of application; a shield must be connected to an external common conductive pathway. However, the new invention provides an alternative to this axiom.

A passive architecture, such as utilized by the invention, can be built to condition or minimize both types of energy fields that can be found in an electrical system. While the invention is not necessarily built to condition one type of field more than another, however, it is contemplated that different types of materials can be added or used to build an embodiment that could do such specific conditioning upon one energy field over another. In the invention, laying horizontal perimeter connections on the sides of the passive component element of the assembly or placement of vertical apertures through passive element, selectively coupling or not coupling these VIAS and/or conductively filled apertures, allows the passage of propagating energy transmissions to occur as if they were going a feed-through-like filtering device.

When prior art interposers are placed into a circuit and energized, their manufacturing tolerances of the devices are carried to the circuit and revealed at circuit energization. These imbalance variables are multiplied with the addition of multiple pathways and cause voltage imbalances in the circuit.

Use of the invention will allow placement into a differentially operated circuitry and will provide a virtually electrically balanced and essentially, equal capacitance, inductive and resistance tolerances of one invention unit, that is shared and located between each paired energy pathway within the device, equally, and in a balanced electrical

manner. Invention manufacturing tolerances or pathway balances between a commonly shared central conductive pathway found internally within the invention is maintained at levels that originated at the factory during manufacturing of the invention, even with the use of common non-conductive materials, dielectrics or conductive materials, which are widely and commonly specified among discrete units. Thus, an invention that is manufactured at 5% tolerance, when manufactured as described in the disclosure will also have a correlated 5% electrical tolerance between single or multiple, paired energy pathways in the invention when placed into an energized system. This means that the invention allows the use of relatively inexpensive materials, due to the nature of the architecture's minimal structure such that variation is reduced and the proper balance between energized paired pathways or differential energy pathways is obtained.

Expensive, non-commonly used, specialized, dielectric materials are no longer needed for many delicate bypass and/or energy decoupling operations in an attempt to maintain a energy conditioning balance between two system conductive pathways, as well as giving an invention users the opportunity to use a single balanced element that is homogeneous in material make up within the entire circuit. The new invention can be placed between paired or a paired plurality of energy pathways or differential conductive pathways in the invention, while the common conductive pathways that also make up the invention can be connected to a third conductive pathway or pathways that are common to all elements of the common conductive pathways internal in the invention and common to an external conductive area, if desired.

The invention will simultaneously provide energy conditioning functions that include bypassing, energy, energy line decoupling, energy storage such that the differential electrodes are enveloped within the embodiment shield structure and are free from almost all internally generated capacitive or energy parasitics trying to escape from the enveloped containment area surrounding each of the conductive pathway electrodes. At the same time, the shield structure will act to prevent any externally generated energy parasitics such as "floating capacitance" for example from coupling onto the very same differential conductive pathways due to the physical shielding and the separation of the electrostatic shield effect created by the energization of the common conductive structure and its attachment with common means known to the art to an internally or externally located conductive area or pathway.

Attachment to an external conductive area includes an industry attachment methodology that includes industry accepted materials and processes used to accomplish connections that can be applied in most cases openly without additional constraints imposed when using a different device architecture. Through other functions such as cancellation or minimization of mutually opposing conductors, the invention allows a low impedance pathway to develop within a Faraday cage-like unit with respect to the enveloping conductive common shields pathways that can subsequently continue to move energy out onto an externally located conductive area that can include, but is not limited to, a "floating", non-potential conductive area, circuit or system ground, circuit system return, chassis or PCB ground, or even an earth ground.

The various attachment schemes described herein will normally allow a "0" voltage reference to develop with respect to each pair or plurality of paired differential conductors located on opposite sides of the shared central and

common conductive pathway, and be equal yet opposite for each unit of a separated paired energy pathway or structure, between the centrally positioned interposing, common conductive shield pathway used. Use of the invention allows voltage to be maintained and balanced even with multiple SSO (Simultaneous Switching Operations) states among transistor gates located within an active integrated circuit all without contributing disruptive energy parasitics back into the energized system as the invention is passively operated, within its attached circuit.

Thus, parasitics of all types are minimized from upsetting the capacitance, inductive and resistance tolerances or balance that were manufactured into the unenergized invention. The prior art has normally allowed effects from free parasitics in both directions to disrupt a circuit despite the best attempts to the contrary with all prior art devices to date.

As previously noted, propagated electromagnetic interference can be the product of both electric and magnetic fields. Until recently, emphasis in the art has been placed upon filtering EMI from circuit or energy conductors carrying high frequency noise with DC energy or current. However, the invention is capable of conditioning energy that uses DC, AC, and AC/DC hybrid-type propagation of energy along conductive pathways found in an electrical system or test equipment. This includes use of the invention to condition energy in systems that contain many different types of energy propagation formats, in systems that contain many kinds of circuitry propagation characteristics, within the same electrical system platform.

Principals of a Faraday cage-like conductive shield like are used when the common conductive pathways are joined to one another and the grouping of these conductive pathways, together co-act with the larger, external conductive pathway, pathway area or surface that provides a greater conductive surface area in which to dissipate over voltages and surges and initiate Faraday cage-like conductive shield structure electrostatic functions of suppression or minimization of parasitics and other transients, simultaneously. When a plurality of common conductive pathways as just described are electrically coupled as either a system, circuit reference node, or chassis ground, they can be relied upon as a commonly used, reference common conductive pathway for a circuit in which the invention is placed into and energized.

One or more of a plurality of conductive or dielectric materials having different electrical characteristics from one another can be inserted and maintained between common conductive pathways and differential electrode pathways. Although a specific differential pathway can be comprised of a plurality of commonly conductive structures, they are performing differentially phased conditioning with respect to a "mate" or paired plurality of oppositely phased or charged structures that form half of the total sum of all of the manufactured differential conductive pathways contained within the structure. The total sum of the differential pathways will also will normally be separated electrically in an even manner with equal number of pathways used simultaneously but with half the total sum of the individual differential conductive pathways approximately 180 degrees out of phase from the oppositely positioned groupings. Microns of dielectric and conductive material normally includes a predetermined type of dielectric along with an interposing and shield functioning common conductive pathway, which in almost all cases and do not physically couple to any of the differentially operating conductive pathways within the invention, itself or its AOC.

In contrast to the prior art, the new invention provides a means of lowering circuit impedance facilitated by pro-

viding interaction of mutually opposing conductive pathways that are maintained in what is essentially, a parallel relationship, respectively within the interposer and with respect to the circuit energy source and the circuit's energy-utilizing load when attached and energized into circuitry between these their energy conduits and to a circuit reference node or common conductive pathway used as a low circuit impedance pathway by portions of propagating energy. At the same time, a entirely different group of mutually opposing conductive pathway elements can be maintained in what is essentially, a parallel relationship respectively to one another and yet be physically perpendicular to the first set of parallel mutually opposing conductive pathway elements simultaneously working in conjunction with the second set just described.

The user has options of connection to an external Gnd area, an alternative common conductive return path, or simply to an internal circuit or system circuit common conductive pathway or common conductive node. In some applications, it might be desired by the user to externally attach to additional numbers of paired external conductive pathways not of the original differential conductive pathways to take advantage of the lowering of circuit impedance occurring within the invention. This low impedance path phenomenon can occur by using alternative or auxiliary circuit return pathways, as well. In this case, at energization, the various internal and simultaneous functions occurring to create a low impedance conductive pathway along the common conductive pathways internal to the new inventive structure is used by portions of energy propagating along the differential conductive pathways in essentially a parallel manner and within the interposer as it normally operates in a position, physically placed in between the various conductive pathways, running from energy source and the energy-utilizing load and back as attached into an energized circuit. Differential conductive energy pathways will be able utilize a circuit "0" Voltage reference image node or "0" Voltage common conductive pathway node created along the internal common conductive pathway in conjunction with the common conductive energy pathway shields that surround the differential conductive pathways almost completely, and coact as a joined together common conductive structure to facilitate energy propagation along the low impedance pathway, not of the differential pathways and allowing unwanted EMI or noise to move to this created pathway at energization and passive operations rather than detrimentally effecting the very circuit and portions of energy that are being conditioned in the AOC of the new interposer.

The attached plurality of internal common conductive electrode pathways that make up a Faraday cage-like conductive shield structure as part of the whole interposer invention will allow the external common conductive area or return pathway to become, in essence, an extended version of itself, internally and closely positioned in an essentially parallel arrangement only microns of distance from differentially operating conductive pathways that are themselves extensions of the external differential conductive elements with respect to their position located apart and on either side of at least one common conductive pathway that is taking on multiple shielding functions simultaneously during energization. This phenomena occurs internally in other embodiments such as, but not limited to, printed circuit boards (PCB), daughter cards, memory modules, test connectors, connectors, interposers for Single Chip Modules or Multi-Chip Modules (SCM or MCM) or other integrated circuit packages utilizing interposer interconnection at subsequent energization.

Additional objects and advantages of the invention will become apparent to those skilled in the art upon reference to the detailed description taken in conjunction with the provided figures.

Turning now to FIG. 1, an exploded perspective view of multi-functional energy conditioner 10's physical architecture is shown. Multi-functional energy conditioner 10 is comprised of a plurality of common conductive pathways 14 at least two electrode pathways 16A and 16B where each electrode pathway 16 is sandwiched between two common conductive pathways 14. At least one pair of electrical conductors 12A and 12B is disposed through insulating apertures 18 or coupling apertures 20 of the plurality of common conductive pathways 14 and electrode pathways 16A and 16B with electrical conductors 12A and 12B also being selectively connected to coupling apertures 20 of electrode pathways 16A and 16B. Common conductive pathways 14 comprise of a conductive material such as metal in a different embodiment, or in the preferred embodiment, they can have conductive material deposited onto a dielectric material or laminate (not shown) similar to processes used to manufacture conventional multi-layered chip capacitors or multi-layered chip energy conditioning elements and the like. At least one pair of insulating apertures 18 are disposed through each common conductive pathway electrode 14 to allow electrical conductors 12 to pass through while maintaining electrical isolation between common conductive pathways 14 and electrical conductors 12. The plurality of common conductive pathways 14 may optionally be equipped with fastening apertures 22 arranged in a predetermined and matching position to enable each of the plurality of common conductive pathways 14 to be coupled securely to one another through standard fastening means such as screws and bolts or in alternative embodiments (not shown) by means that allow the device to be manufactured and joined into a standard monolithic-like, multilayer embodiments similar to the processes used in the industry to manufacture prior art chip energy conditioning elements and the like. Fastening apertures 22 or even a solder attachment of common industry means and materials that can subsequently place conductive termination bands (not shown) may also be used to secure multi-functional energy conditioner 10 to another non-conductive or common conductive surface such as an enclosure or chassis of the electronic system or device the multi-functional energy conditioner 10 is being used in conjunction with.

Electrode pathways 16A and 16B are similar to common conductive pathways 14 in that they are comprised of a conductive material or in a different embodiment, can have conductive material deposited onto a dielectric laminate (not shown) or similar, that would allow the new embodiment to be manufactured and joined into a standard monolithic-like, multilayer embodiments similar to the processes used in the industry to manufacture prior art chip energy conditioning elements and the like and have electrical conductors 12A and 12B disposed through respective apertures. Unlike joined, common conductive pathways 14, electrode pathways 16A and 16B are selectively electrically connected to one of the two electrical conductors 12. While electrode pathways 16, as shown in FIG. 1, are depicted as smaller than common conductive pathways 14 this is not required but in this configuration has been done to prevent electrode pathways 16 from interfering with the physical coupling means of fastening apertures 22 or other bonding methods (not shown) and should be ideally inset within the common conductive pathways 14 and thus they possess a smaller conductive area than common conductive pathways 14.

Electrical conductors **12** provide a current path that flows in the direction indicated by the arrows positioned at either end of the electrical conductors **12** as shown in FIG. 1. Electrical conductor **12A** represents an electrical propagating conveyance path and electrical conductor **12B** represents the propagating energy return path. While only one pair of electrical conductors **12A** and **12B** is shown, Applicant contemplates multi-functional energy conditioner **10** being configured to provide filtering with a plurality of pairs of electrical conductors like **12A** and **12B**, as well as, electrode pathways **16A** and **16B** and common conductive pathways **14** which are joined together for creating a high-density multi-conductor multi-functional energy conditioner.

Another element which makes up multi-functional energy conditioner **10** is material **28** which has one or a number of electrical properties and surrounds the center common conductive pathway electrode **14**, both electrode pathways **16A** and **16B** and the portions of electrical conductors **12A** and **12B** passing between the two outer common conductive pathways **14** in a manner which isolates the pathways and conductors from one another except for the connection created by the conductors **12A** and **12B** and coupling aperture **20**. The electrical characteristics of multi-functional energy conditioner **10** are determined by the selection of material **28**. If an X7R dielectric material is chosen, for example, multi-functional, energy conditioner **10** will have primarily capacitive characteristics. Material **28** may also be a metal oxide varistor material that will provide capacitive and surge protection characteristics. Other materials such as ferrites and sintered polycrystalline may be used wherein ferrite materials provide an inherent inductance along with surge protection characteristics in addition to the improved common mode noise cancellation or minimization that results from the mutual coupling cancellation or minimization effect. The sintered polycrystalline material provides conductive, dielectric, and magnetic properties. Sintered polycrystalline is described in detail in U.S. Pat. No. 5,500,629, which is herein incorporated by reference.

Still referring to FIG. 1, the physical relationship of common conductive pathways **14**, electrode pathways **16A** and **16B**, electrical conductors **12A** and **12B** and material **28** will now be described in more detail. The starting point is center common conductive pathway electrode **14**. Center pathway **14** has the pair of electrical conductors **12** disposed through their respective insulating apertures **18** which maintain electrical isolation between common conductive pathway electrode **14** and both electrical conductors **12A** and **12B**. On either side, both above and below, of center common conductive pathway electrode **14** are electrode pathways **16A** and **16B** each having the pair of electrical conductors **12A** and **12B** disposed there through. Unlike center common conductive pathway electrode **14**, only one electrical conductor, **12A** or **12B**, is isolated from each electrode pathway, **16A** or **16B**, by an insulating aperture **18**. One of the pair of electrical conductors, **12A** or **12B**, is electrically coupled to the associated electrode pathway **16A** or **16B** respectively through coupling aperture **20**. Coupling aperture **20** interfaces with one of the pair of electrical conductors **12** through a standard connection such as a solder weld, a resistive fit or any other standard interconnect methodology to provide a solid and secure physical and electrical connection of predetermined conductive pathways. For multi-functional energy conditioner **10** to function properly, upper electrode pathway **16A** must be electrically coupled to the opposite electrical conductor **12A** than that to which lower electrode pathway **16B** is electrically coupled, that being electrical conductor **12B**. Multi-functional energy

conditioner **10** optionally comprises a plurality of outer common conductive pathways **14**.

These outer common conductive pathways **14** provide a significantly larger conductive common conductive pathway and/or image plane when the plurality of common conductive pathways **14** are electrically connected to an outer edge conductive band **14A** by conductive termination material or attached directly by tension seating means or commonly used solder-like materials to an larger external conductive surface. **14A** and **14B** (not shown) that are physically separate of the differentially conductive pathways **16A** and **16B** and/or any plurality of electrical conductors such as **12A** and **12B** for example. Connection to an external conductive area helps with attenuation of radiated electromagnetic emissions and provides a greater surface area in which to dissipate over voltages and surges. Connection to an external conductive area helps electrostatic suppression or minimization of any inductive or parasitic strays that can radiate or be absorbed by differentially conductive pathways **16A** and **16B** and/or any plurality of differential electrical conductors such as **12A** and **12B** for example.

Principals of a Faraday cage-like conductive shield structure are used when the common pathways are joined to one another as described above and the grouping of common conductive pathways together coact with the larger external conductive area or surface to suppress radiated electromagnetic emissions and provide a greater conductive surface area in which to dissipate over voltages and surges and initiate Faraday cage-like conductive shield structure electrostatic functions of suppression or minimization of parasitics and other transients, simultaneously. This is particularly true when plurality of common conductive pathways **14** are electrically coupled to earth ground but are relied upon to provide an inherent common conductive pathway for a circuit in which the invention is placed into and energized with. As mentioned earlier, inserted and maintained between common conductive pathways **14** and both electrode pathways **16A** and **16B** is material **28** which can be one or more of a plurality of materials having different electrical characteristics.

FIG. 1A shows an alternative embodiment of multi-functional energy conditioner **10**, which includes additional means of coupling electrical conductors or circuit board connections to multi-functional energy conditioner **10**. Essentially, the plurality of common conductive pathways **14** are electrically connected together by the sharing of a separately located outer edge conductive band or bands **14A** and/or **14B** (not shown) at each conductive electrode exit and which in turn, are then joined and/or connected to the same external conductive surface (not shown) that can possess a voltage potential when the invention is placed into a portion of a larger circuit and energized. This voltage potential coacts with the external conductive surface area or areas through conductive bands **14A** and/or **14B** (not shown) and the internal common conductive electrodes **14** of the embodiment, as well as any of the conductive elements (shown or not shown) that are needed to utilize a connection that allows energy to propagate.

In addition, each differential electrode pathway **16A** and **16B** has its own outer edge conductive bands or surface, **40A** and **40B** respectively. To provide electrical connections between electrode pathway **16A** and **16B** and their respective conductive band **40A** and **40B** while at the same time maintaining electrical isolation between other portions of multi-functional energy conditioner **10**, each electrode pathway **16** is elongated and positioned such that the elongated portion of electrode pathway **16A** is directed opposite of the

direction electrode pathway **16B** is directed. The elongated portions of electrode pathways **16** also extend beyond the distance in which the plurality of common conductive pathways common conductive pathways **14** extend with the additional distance isolated from outer edge conductive bands **40A** and **40B** by additional material **28**. Electrical connection between each of the bands and their associated pathways is accomplished through physical contact between each band and its associated common conductive or conductive electrode pathway, respectively.

FIG. 2 shows a quasi-schematic circuit representation of an energized portion of a circuit when the physical embodiment of multi-functional energy conditioner **10** is mated into a larger circuit and energized. Line-to-line energy conditioning element **30** is comprised of electrode pathways **16A** and **16B** where electrode pathway **16A** is coupled to one of the pair of electrical conductors **12A** with the other electrode pathway **16B** being coupled to the opposite electrical conductor **12B** thereby providing the two parallel pathways necessary to form an energy conditioning element. Center common conductive pathway electrode **14** is an essential element among all embodiments or connotations of the invention and when joined with the sandwiching outer two common conductive pathways **14** together act as inherent common conductive pathway **34** and **34b** which depicts conductive band **14** and **14B** (not shown) as connecting to a larger external conductive area **34** (not shown) and line-to-line energy conditioning element **30** and also serves as one of the two parallel pathways for each line-to-common conductive pathway energy conditioning element **32**.

The second parallel pathway required for each line-to-common conductive pathway energy-conditioning element **32** is supplied by the corresponding electrode pathway **16B**. By carefully referencing FIG. 1 and FIG. 2, the energy conditioning pathway relationships will become apparent. By isolating center common conductive pathway electrode **14** from each electrode pathway **16A** or **16B** with material **28** having electrical properties, the result is an energy conditioning network having a common mode bypass energy conditioning element **30** extending between electrical conductors **12A** and **12B** and line-to-common conductive pathway decoupling energy conditioning elements **32** coupled from each electrical conductor **12A** and **12B** to larger external conductive area **34**.

The larger external conductive area **34** will be described in more detail later but for the time being it may be more intuitive to assume that it is equivalent to earth or circuit ground. The larger external conductive area **34**, can be coupled with the center and the additional common conductive pathways **14** to join with said central pathway **14** to form, one or more of common conductive pathways **14** that are conductively joined and can be coupled to circuit or earth ground by common means of the art such as a soldering or mounting screws inserted through fastening apertures **22** or just laminated as a standard planar multilayered ceramic embodiment (not shown) with externally deposited conductive material like **14A** and **14B** which are then together coupled to the same external common conductive area or pathway (not shown) an enclosure or grounded chassis of an electrical device. While multi-functional energy conditioner **10** works equally well with inherent common conductive pathway **34** coupled to earth or circuit common conductive pathway, one advantage of multi-functional energy conditioner **10**'s physical architecture is that depending upon energy condition that is needed, a physical grounding connection can be unnecessary in some specific applications.

Referring again to FIG.1 an additional feature of multi-functional energy conditioner **10** is demonstrated by clock-

wise and counterclockwise flux fields, **24** and **26** respectively. Maxwell's fourth equation, which is also identified as Ampere's law, states that magnetic fields arise from two sources, the first source is described as current flow in the form of a transported electrical charge and the second source is described by how the changes in electric fields traveling in a closed loop circuit will subsequently create simultaneous, magnetic fields. Of the two sources just mentioned, transported electrical charge is the description of how electric currents create magnetic fields that if the conductive source pathway and the return energy pathway are so positioned, mathematical equations can be used to describe how E & H Fields can be suppressed or minimized within the new interposer device.

To minimize RF currents within any passive component or layered structure that is being used in an energy transmission network, the concept of flux cancellation or flux minimization needs to be used. Because magnetic lines of flux travel counterclockwise within a transmission line or line conductor or layer, if we bring the RF return path parallel and adjacent to its corresponding source trace, the magnetic flux lines observed in the return path (counterclockwise field), related to the source path (clockwise field), will be in the opposing directions. When we combine a clockwise field with a counterclockwise field, a cancellation or minimization effect is observed.

If unwanted magnetic lines of flux between a source and return path are canceled or minimized, then a radiated or conducted RF current cannot exist except within the minuscule boundary of the conductive pathway inside. However, by using techniques described herein, this minuscule boundary of escaping RF energy is critical in high-speed applications and is effectively contained by the energized shield structure almost entirely enveloping the differential conductive pathway. The concept of implementing flux cancellation or minimization is simple, especially when the opposing conductors can be positioned vertically and horizontally with respect to the earth's horizon, within microns of distance to one another. The invention suppression or minimization techniques occurring simultaneously to one another during flux cancellation or minimization creates and follows convention theory as it is prescribed with the use of image planes or nodes. Regardless of how well designed a passive component is, magnetic and electric fields will normally be present to some small insignificant amount, even at speeds above 2 Gigahertz and beyond. However, if we cancel or minimize magnetic lines of flux effectively and then combine this cancellation or minimization technique with use of an image plane and shielding structures then EMI cannot exist.

To explain this concept further, the direction of the individual flux fields is determined and may be mapped by applying Ampere's Law and using the right hand rule. In doing so, an individual places their thumb parallel to and pointed in the direction of current flow through electrical conductors **12A** or **12B** as indicated by the arrows at either ends of the conductors. Once the thumb is pointed in the same direction as the current flow, the direction in which the remaining fingers on the person's hand curve indicates the direction of rotation for the flux fields. Because electrical conductors **12A** and **12B** are positioned next to one another and they can also represent a more than one current loop as found in many I/O and data line configurations, the currents entering and leaving multi-functional energy conditioner **10** oppose one another, thereby creating a closely positioned opposed flux fields **18**, **20**, **24**, **26** which cancel or minimize each other and cancel or minimize inductance attributed to the device.

Low inductance is advantageous in modern I/O and high-speed data lines as the increased switching speeds and fast pulse rise times of modern equipment create unacceptable voltage spikes which can only be managed by low inductance surge devices and networks. It should also be evident that labor intensive aspects of using multi-functional energy conditioner **10** as compared to combining discrete components found in the prior art provides an easy and cost effective method of manufacturing. Because connections only need to be made to either ends of electrical conductors **12** to provide a line to line capacitance to the circuit that is approximately half the value of the capacitance measured for each of the line to common conductive pathway capacitance also developed internally within the embodiment. This provides flexibility for the user as well as providing a potential savings in time and space in manufacturing a larger electrical system utilizing the invention.

A portion of a Faraday-cage-like common conductive shield structure found in the present invention is shown in detail in FIG. 3 and in FIG. 4. Accordingly, discussion will move freely between FIG. 3 and FIG. 4 to disclose the importance that a Faraday-cage-like common conductive shield structure plays in combination with various external common conductive pathways. FIG. 3 shows a portion **800B**, which comprises a portion of the complete Faraday cage-like conductive shield structure **20** as shown in FIG. 4.

In FIG. 3, differential conductive by-pass electrode pathway **809** is sandwiched between the shared, central common conductive pathway **804/804-IM** of structure **20** and common conductive pathway **810** (not shown in FIG. 3), which is seated above pathway **809** in depiction FIG. 4. Positioned above and below by-pass pathway **809** is a dielectric material or medium **801**. Common conductive pathways **804/804-IM** and **810**, as well as pathway **809**, are all separated from each other for the most part by a general parallel interposition of a predetermined dielectric material or medium **801**, which is placed or deposited during the manufacturing process between each of said conductive pathway applications. All of the conductive common conductive pathways **860/860-IM**, **840**, **804/804-IM**, **810**, **830**, and **850/850-IM** are offset a pre-determined distance **814** from the outer edge of embodiment **800B**. In addition, all of the differential conductive pathways **809** are offset an additional distance **806** from the outer edge of embodiment **800B** such that the outer edge **803** of differential conductive pathway **809** is overlapped by the edge **805** of the common conductive pathways. Accordingly, differential conductive pathway **809** comprises a conductive area that will always be less than any of one conductive area of any given said common conductive pathways' conductive area when calculating its' total conductive area. The common conductive pathways will generally all possess nearly the same as manufacturability controllable conductive area that is homogenous in area size to on another as well in general make-up. Thus, any one of the sandwiching common conductive pathway's will possess a total top and bottom conductive area sum always greater than the total conductive area top and bottom summed of any one differential conductive pathway and will always be almost completely physically shielded by the conductive area of any common conductive pathway of Faraday-cage-like common conductive shield structure.

Looking at FIG. 4, it is seen that common pathways **860/860-IM**, **840**, **804/804-IM**, **810**, **830**, and **850/850-IM** are also surrounded by dielectric material **801** that provides support and outer casing of the interposer component. Conductive connection material or structures **802A** and **802B** are

applied to a portion of said common shield pathway structures edges **805** of said common pathways of a structure **20** on at least two sides as is depicted in FIG. 4 and as is depicted for **804/804-IM** in FIG. 3. This enables the electrical conditioning functions to operate properly in this type of embodiment. A break down of structure **20** into even smaller, paired, cage-like conductive structure portions reveals for example conductive structure **900A** which is further comprised of common conductive pathways **804/804-IM**, **808** and **810**, individually, and now together, with common conductive material connections **802A** and **802B** that will form a single, common conductive, center structure **900A** of larger structure **20** that would alone, operate sufficiently as one common conductive cage-like structure of **900A**, if built as such, individually and connected in a similar manner into a circuit.

To condition additional differential conductive pathways (not shown), as part of a larger stacking of a interposer utilizing common conductive pathway electrodes could be added in a pre-determined fashion, for by-pass as shown in FIG. 3 or for a feed-thru configuration, not shown, but disclosed in pending applications referenced herein. All that is needed for proper device functions, as long as conductive connection material connections **802A** and **802B** maintain physical and electrical contact with some portion of common pathways edge electrodes **805** of each, respective, common conductive pathways and as long as each and every differential pathway is sandwiched by at least two common conductive pathways and said differential conductive pathways are set-back in a generally equal **806** positioning so that the stacked yet separated differential electrodes, each embodiment may operate the units minimization and suppression functions in a balanced manner with respect to conductive material areas as just discussed.

Returning to FIG. 4, paired, differential energy propagation shielded container comprising conductive pathways similar to **809** and **818** (not shown) in FIG. 3 will utilize conductive connection material or structures **802A** and **802B** that comprises a conductive material generally known and used in the art to electrically connect conductive pathways to one another in a typical circuit system as can be done using prior art methodologies.

Before embodiment **20** of FIG. 4 is placed into circuitry and energized, structures **802A** and **802B** should electrically connect conductive pathways to one another in a typical circuit system and provide externally located conductive pathways or areas (not shown) or same external conductive paths (not shown) a good electrical connection without any conductive interruption or gap between each respective conductive structures **802A** and **802B**.

In FIG. 3, single cage-like structure **800B** mirrors single cage-like structure **800C** except that differential electrode **818** (not shown) contained within, and exit/entrance sections **812A** and **812B** (not shown) as well as conductive pathway extension structures **812A** and **812B** (not shown), are positioned in a generally opposite placement position relative to one another or its paired mate in multi-paired applications, and will operate in an electrically balanced manner with one another conductive pathway differential electrode of conductive structure **809B** (not shown) with exit/entrance section **812B** (not shown) that can be in a generally opposing direction, approx. 180 degrees to that of conductive pathway differential electrode of conductive structure **809A** with exit/entrance section **812A**. Differential structures contained within these two commonly conductive, cage-like structures or common containers **800C** and **800B** are in a positioned and electrically parallel relationship, but most importantly,

structures **800C** and **800B** comprising structure **900A** are sharing the same, central common conductive shared pathway **804/804-IM**, that makes up part of each smaller cage-like structures, **800C** and **800B**, when taken individually. Together, **800C** and **800B** create a single and larger conductive Faraday-cage-like common conductive shield structure **900A** that acts as a double or paired shielded common conductive pathway container.

Each container **800C** and **800B** can hold an equal number of same sized, differential electrodes that are not necessarily physically opposing one another within larger structure **900A**, yet are oriented in a generally physically and electrically parallel manner, respectively. Larger, conductive faraday-cage-like common conductive shield structure **900A** with co-acting **800C** and **800B** individual shield-like structures, when energized, and attached to the same external common conductive path area by common conductive material connections **802A** and **802B** by any possible means of commonly acceptable industry attachment methods such as reflux solder conductive epoxies and adhesives and the like (but not shown), become one electrically, at energization.

The predetermined arrangements of the common conductive electrodes are shown in FIG. 4, with common conductive electrode **810** and **808** with a centralized common shield **804/804-IM** connected by common conductive material connections **802A** and **802B** to an external common conductive pathway or area some of the elements that make up one common conductive cage-like structure **900A**. Common conductive cage-like **800B** is an element of the present invention, namely the energy conditioning interposer with circuit architecture.

The central common conductive shared pathway **804/804-IM** with respect to its interposition between the differential electrodes **809** and **818** (not shown) needs the outer two additional sandwiching common electrode pathways **808** and **810** to be considered an un-energized, Faraday cage-like conductive shield structure **900A**. To go further, the central common pathway **804/804-IM** will be used simultaneously by both differential electrodes **809** and **818**, at the same time, but with opposite results with respect to charge switching.

The following sections that reference to common conductive pathway **804/804-IM**, also apply to common conductive pathways **808** and **810**. Common conductive pathway **804/804-IM** is offset a distance **814** from the edge of the invention. One or more portions **811A** and **811B** of the common conductive pathway electrode **804/804-IM** extends through material **801** and is attached to common conductive band or conductive material structures **802A** and **802B**. Although not shown, common **802A** and **802B** electrically connects common conductive pathways **804/804-IM**, **808** and **810** to each other and to all other common conductive pathways (**860/860-IM**, **840**, **830**, and **860/860-IM**) if used.

This offset distance and area **806** of FIG. 3, enables the common conductive pathway **804/804-IM** to extend beyond the electrode pathway **809** to provide a shield against portions of energy flux fields (not shown) which might have normally attempted to extend beyond the edge **803** of the electrode pathway **809** but were it not for the electrostatic shielding effect of an energized faraday-like cage systems resulting in reduction or minimization of near field coupling between other internal electrode pathways such as **818** (not shown) or to external differential electrode pathways elements. The horizontal offset **806** can be stated as approximately 0 to 20+ times the vertical distance **806** between the

electrode pathway **809** and the common conductive pathway **804/804-IM**. The offset distance **806** can be optimized for a particular application, but all distances of overlap **806** among each respective pathway is ideally, approximately the same, as manufacturing tolerances will allow. Minor size differences are unimportant in distance and area **806** between pathways as long as electrostatic shielding function (not shown) of structure **900A** or structure **20** is not compromised.

In order to connect electrode **809** to energy pathways positioned external to **809**, yet on either side of the **800B**, respectively (not shown), the electrode **809** may have one, or a plurality of, portions **812** which extend beyond the edge **805** of the common conductive pathways **804/804-IM** and **808** to a connection area **812A** and **812B** which are in turn conductively connected to conductive pathway material, deposit or electrode **809A** and **809B**, which enables the by-pass electrode **809** to be electrically connected to the energy pathways (not shown) on either side. It should be noted that element **813** is a dynamic representation of the center axis point of the three-dimensional energy conditioning functions that take place within the interposer invention (not shown) and is relative with respect to the final size, shape and position of the embodiment in an energized circuit.

Referring now to FIG. 4, the concept of the universal, multi-functional, common conductive shield structure (for use with the applicants discreet, non-interposer energy conditioners) is shown. The universal, multi-functional, common conductive shield structure **20** comprises multiple, stacked, common conductive cage-like structures **900A**, **900B** and **900C** as depicted and which in turn are comprised of multiple, stacked, common conductive cage-like structures or containers **800A**, **800B**, **800C**, and **800D** (each referred to generally as **800X**), in a generally parallel relationship. Each common conductive cage like structure **800X** comprises at least two common conductive pathway electrodes, **830**, **810**, **804/804-IM**, **808**, or **840**. The number of stacked, common conductive cage-like structures **800X** is not limited to the number shown herein, and can be any even integer. Thus the number of stacked, common conductive cage-like structures **900X** is also not limited to the number shown herein and could be of an even or odd integer. Although not shown, in other applications, each paired common conductive cage-like structure **800X** sandwiches at least one conductive pathway electrode as previously described in relation to FIG. 3. The common conductive cage-like structures **800X** are shown separately to emphasize the fact they are paired together and that any type of paired conductive pathways can be inserted within the respective common conductive cage like structures **800X**. As such, the common conductive cage-like structures **800X** have a universal application when paired together to create larger common conductive cage-like structures **900X**, which are delineated as **900B**, **900A** and **900C**, respectively and can be used in combination with paired conductive pathways in discrete, or non-discrete configurations such as, but not limited to, embedded within silicone or as part of a PCB, discreet component networks, and the like.

The common conductive pathway electrodes **830**, **810**, **804/804-IM**, **808**, **840**, are all conductively interconnected as shown at **802A** and **802B(s)** which provide connection point(s) to an external conductive area (not shown). Each common conductive pathway electrode **830**, **810**, **804/804-IM**, **808**, **840**, is formed on dielectric material **801** to edge **805** and reveal opposite side bands also comprised of dielectric material **801**.

As has described in FIG. 3, the dielectric material **801**, conductively separates the individual common conductive pathway electrodes **830**, **810**, **804/804-IM**, **808**, **840**, from the conductive pathway electrodes (not shown) sandwiched therein. In addition, as described in relation to FIG. 3, a minimum of two cages, for example **800B** and **800C**, which make up larger cage **900A**, are required to make up a multi-functional line-conditioning structure for use in all of the layered embodiments of the present invention. Accordingly, there are a minimum of two required common conductive cage like structures **800X**, as represented in FIG. 4 per each **900A**, **900B**, and **900C**, respectively. No matter the amount of shield layers used or the processes that derive the final form are arrived at, the very basic common conductive pathway manufacturing result of any sequence (excluding dielectric materials, etc.) should appear as an embodiment structure that is as follows: a first common conductive pathway, then a conductive pathway (not shown), then a second common conductive pathway, second conductive pathway (not shown) and a third common conductive pathway. The second common conductive pathway in the preceding results becomes the centrally positioned element of the result. For additional layering of pathways desired, additional results of a manufacturing sequence would yield as follows for example, a third conductive pathway (not shown), then a fourth common conductive pathway, a fourth conductive pathway (not shown); then a fifth common conductive pathway. If an image shield configuration is desired to be used as is shown in FIG. 4 as pathways **850/850-IM** and **860/860-IM** there is no difference in the first layer result other than a last set of sandwiching common conductive pathways **850/850-IM** and **860/860-IM** are added. Again as a result of almost any manufacturing sequence as follows: (excluding dielectric material, etc.) **860/860-IM** common conductive pathway is placed, then a first common conductive pathway, then a conductive pathway (not shown), then a second common conductive pathway, second conductive pathway (not shown) and a third common conductive pathway a third conductive pathway (not shown), then a fourth common conductive pathway, a fourth conductive pathway (not shown); then a fifth common conductive pathway, finally a **850/850-IM** common conductive pathway will be the resulting structure for this example in FIG. 4. In summary, most chip, non-hole thru embodiments of the applicants discreet, non-interposer energy conditioners will have a minimum of two electrodes **809** and **809'** (not shown) sandwiched between three common conductive electrodes **808** (not shown) and **804/804-IM** and **810** (not shown), respectively, and a minimum of two electrodes **809** and **809'** (not shown) connect to external structures **809A** and **809A'** (not shown). Three common conductive electrodes **808** (not shown) and **804/804-IM** and **810** (not shown), respectively and connected external structures **802A** and **802B** are connected such that they are conductively considered as one to form a single, larger Faraday-cage-like structure **900A**. Thus when a single, larger Faraday-cage-like structure **900A** is attached to a larger external conductive area (not shown), the combination helps perform simultaneously, energized line conditioning and filtering functions upon the energy propagating along the conductors **809** and **809'** (not shown), sandwiched within the cage-like structure **900A**, in an oppositely phased or charged manner. Connection of the joined common conductive and enveloping, multiple common shield pathways **808** (not shown) and **810** (not shown), respectively with a common centrally located common conductive pathway **804/804-IM** will become like the extension of external

conductive element **6803**, as shown in FIG. 5B and will be interposed in such a multiple parallel manner that said common conductive elements will have microns of distance separation or 'loop area' with respect to the complimentary, phased differential electrodes that are sandwiched themselves and yet are separated from the extension of external conductive element like **6803**, shown in FIG. 5B by a distance containing a dielectric medium.

This enables the extension of external conductive element like **6803**, shown in FIG. 5B to perform electrostatic shielding functions, among others, that the energized combination as just described will enhance and produce efficient, simultaneous conditioning upon the energy propagating on or along said portions of assembly **900A**'s differential conductors **809** and **809'** (not shown). The internal and external parallel arrangement groupings of a combined common conductive **900A** will also cancel or suppress unwanted parasitics and electromagnetic emissions that can escape from or enter upon portions of said differential conductors differential conductors **809** and **809'** (not shown) used by said portions of energy as it propagates along a conductive pathways (not shown) to active assembly load(s), which is explained further, below with FIG. 5A.

Referring now to FIGS. 5A and 5B, a further embodiment of the layered, universal, multi-functional common conductive shield structure of the present invention is shown in a by-pass configuration **6800** hereinafter referred to as "by-pass shield structure". By-pass shield structure **6800** could also take on a configuration of "feed-thru shield structure" **6800** in terms of relative stacking position of a static embodiment of each. There would be relatively no difference between these two possible configurations when inspecting the positioning of stacked two common conductive shield structures **1000A** and **1000B** or of common conductive pathways **6808**, **6810**, **6811**, **6812** and central common shared conductive pathway **6804** that could make up each embodiment. While appearing physically similar in arrangement "feed-thru shield structure" **6800** and "by-pass shield structure" **6800**, each would still yield the same possible functional contribution to the energy conditioning of a circuit. However, the way to which the non-common pathways **6809** and **6807** are constructed and subsequently positioned with respect to circuit pathway attachments would also determine the final type of energy conditioning results that could be expected in the circuit. Whatever configuration, the various shielding functions, physical and electrical, work about the same way with respect to propagated energy (not shown) in the AOC of By-pass shield structure **6800**.

Referring specifically to FIG. 5A, the by-pass shield structure **6800** is shown in cross section extending longitudinally and comprises a seven layer common conductive pathway stacking of two common conductive shield structures **1000A** and **1000B**, which form the present embodiment of the by-pass shield structure **6800**. In FIG. 5B, the by-pass shield structure **6800** is shown in cross section perpendicular to the cross section shown in FIG. 5A.

Referring to both FIGS. 5A and 5B, the by-pass shield structure **6800** comprises a central common conductive shared pathway **6804** that is connected with elements **6808**, **6810**, **6811**, **6812** and energized and will form a zero voltage reference to circuitry (not shown) with the creation of **6804-IM**, **6811-IM** and **6812-IM** which is formed and relative only to the active circuit elements attached commonly (not shown), but not before connection of the **6802A** and **6802B(s)** by connection means **6805** to external conductive surface **6803**. With energization, the circuitry (not shown)



will include a passively operating universal, multi-functional, common conductive shield structure **6800** that will be used by energy source (not shown) and energy-utilizing load (s) with propagated energy in a balanced manner that will be available when energized active components (not shown) in said circuitry (not shown) demand portions of said energy. Elements as just described including portions of all of the common conductive elements in the chain of connections to **6803** as just described will have created for said energized circuit elements **6807**, **6820**, **6809**, **6821**, a zero voltage reference, **6811-IM**, **6804-IM**, **6812-IM** respectively, and with central common conductive shared pathway **6804**, electrically balance coupled energy within the circuit (not shown) with the formation of a third but common electrical node, separate of the two distinct and separate differential nodes utilized by differential conductive pathways **6809** and **6807** and their respective conductively linking elements **6820** and **6821**.

In order to couple by-pass shield structure **6800** to an energized circuit, differential conductive pathways **6807** and **6809**, respectively, are each inserted into one of the two common conductive shield structures. The first common conductive shield structure **1000A** is formed between common conductive pathway **6810** and central common conductive shared pathway **6804**. The second common conductive shield structure **1000B** is formed between common conductive pathway **6808** and central common conductive-shared pathway **6804**. To use by-pass shield structure **6800** a first differential conductive pathway **6807** is placed within the first common conductive shield structure and separated from the common conductive pathway **6810** and the central common conductive-shared pathway **6804** by a dielectric material **6801**. The dielectric material **6801** separates and electrically isolates the first differential conductive pathway **6807** from the first common conductive shield structure. In addition, a second differential conductive pathway **6809** is placed within the second common conductive shield structure and separated from the common conductive pathway **6808** and the central common conductive-shared pathway **6804** by a dielectric material **6801**.

The first and second differential conductive pathways **6807** and **6809**, respectively, are then electrically connected to external conductive energy pathways **6820** and **6821**, respectively. The electrical connections can be made by any means known to a person of ordinary skill in the art, including but not limited to solder, resistive fit sockets, and conductive adhesives. Completing the by-pass shield structure **6800** are the additional outer shield structures **6811** and **6812**, which sandwich both common conductive shield structures **1000A** and **1000B** with dielectric material **6801** interposed between. Each of the outer common conductive shields **6811** and **6812** form image structures **6811-IM** and **6812-IM** as just described, when energized, that includes an outer conductive portion of shields **6811** and **6812** (not shown) and the outer conductive portions of external common conductive electrode structure(s) **6802A** and **6802B** that forms a relatively large skin area and a zero voltage reference with **6804-IM** by external common conductive structure **6803**. The outer skin surface formed by the combination of the external common conductive electrode structure **6802A** and **6802B** and the outer shield image structures **6811-IM** and **6812-IM** absorbs energy when the circuit is energized and than act as an additional enveloping shield structure with respect to **6809** and **6807** differential conductive pathways. If the by-pass shield structure **6800** is attached to an external common conductive pathway **6803** of an energy conditioning circuit assembly ('ECCA') by known

means **6805**, such as solder material, portions of energy will travel along the created low impedance pathway that exists internally, with common conductive structure elements **6812**, **6808**, **6804**, **6810**, **6811** **6802A** and **6802B**, and the external connection **6805** to third conductive pathway **6803** and be able to return by this pathway **6803** to its source.

The external common conductive electrode structure(s) **6802A** and **6802B** are connected to electrical circuits by means known in the art and therefore the present invention is not limited to discreet structures but could, for example, be formed in silicon within an integrated circuit. In operation, by-pass shield structure **6800** and the two common conductive shield structures **1000A** and **1000B**, effectively enlarge the zero voltage reference **6804-IM**, **6811-IM** and **6812-IM** within the area of convergence AOC **6813**. The AOC **6813** is the energy central balance point of the circuit.

The result of the by-pass shield structure **6800** when energized within a circuit is increased physical shielding from externally generated and internally propagating parasitics **6816** (represented by the double sided arrows) as well as providing lower impedance paths generated along the common conductive pathway electrode **6812**, **6808**, **6804**, **6810**, **6811** **6802A** and **6802B**, surfaces to external conductive pathway **6803**. The electrostatic functions (not shown) occur in an energized state to energy parasitics **6816**, which are also representative of portions of externally and internally originating energy parasitics **6816** that would otherwise disrupt portion of propagated energy. The double-sided arrows show the charged electron exchange representative of the electrostatic functions that occur in an energized state to trap parasitics **6816** within a shielded container. The double-sided arrows also represent the simultaneous, but opposite charge affect that occurs along the 'skins' of the conductive material that is located within each respective container.

Turning now to FIG. 6A, a layering sequence of a surface mount energy conditioning interposer **30** with circuit architecture is shown. Interposer **30** comprises a minimum of two differential conductive pathways **303**, **305**. Interposer **30** also comprises a minimum of three common conductive pathway layers **302**, **304**, **306**, which are electrically interconnected and surround the differential conductive pathways **303**, **305**, both above and below, to form a large Faraday cage-like common conductive shield structure about each paired differential pathways, as has been previously disclosed. In one embodiment, interposer **30** also comprises an additional common conductive pathway layer **301/301-IM**, **307/307-IM**, or image shield layer, stacked on the outer common conductive pathway layers **302** and **306**. These image shield layers **301/301-IM**, **307/307-IM** are also electrically interconnected to the other common conductive pathway layers **302**, **304**, and **306**. The centrally positioned common conductive pathway **304** separates differential conductive pathways **303**, and **305**. Common conductive pathway **304** is shared such that it forms a portion of a Faraday cage-like conductive shield structure surrounding both the first and second differential conductive pathways **303** and **305**.

Each common conductive pathway layer **301/301-IM**, **302**, **304**, **306**, **307/307-IM** comprises a conductive electrode material **400** deposited in a layer surrounded on at least a portion of a perimeter thereof by an insulation band **34**. Insulation band **34** is made of a non-conductive material or dielectric material. Protruding through the insulation bands **34** on the perimeter of each common conductive pathway layer **301/301-IM**, **302**, **304**, **306**, **307/307-IM** are electrode extensions **32**, **35** which facilitate connections between the

common conductive pathways and I/O of various IC chips (not shown) in addition to other external connections to common conductive pathways or other shields. Similarly, first and second differential conductive layers **303**, **305** comprise a conductive electrode material **400** deposited in a layer surrounded on at least a portion of a perimeter thereof by an insulation band **37** and **38**, respectively. Insulation bands **37** and **38** are made of a non-conductive material, dielectric material, or even can be simply an absence of conductive material on the same layer of material that the conductive material resides upon. It should be noted that insulation bands **37** and **38** are generally wider than insulation band **34** of the common conductive pathway layers **301/301-IM**, **302**, **304**, **306**, **307/307-IM** such that there is an overlap or extension of the common conductive pathway layers beyond the edge of the first and second differential conductive pathways as has been previously discussed. First and second differential conductive layers **303**, **305** include multiple location electrode extensions **36** and **39**, respectively, which facilitate connections to the internal integrated circuit traces and loads in addition to connections to the external energy source and/or lead frame.

As with previous embodiments, the layers **301/301-IM**, **302**, **303**, **304**, **305**, **306**, and **307/307-IM** are stacked over top of each other and sandwiched in a parallel relationship with respect to each other. Each layer is separated from the layer above and below by a dielectric material (not shown) to form energy conditioning interposer **30**.

In FIG. **6B**, an integrated circuit **380** is shown mounted in a carrier, in the form of an IC or DSP package **310** configured with connected wire pin outs (not shown). As generally indicated at **300**, an integrated circuit die is placed within IC package **310** with one section removed and exposed for viewing of the internal and external interconnections features displaying the finished energy conditioning interposer **30** of FIG. **6A**. Interposer **30** includes electrode termination bands **320** and **321** to which all of the common conductive pathways are coupled are connected together at their respective electrode extensions **32** and **35**. These common conductive electrode termination bands **320** and **321** can also be connected to a metalized portion of the IC package **310** and used as a "0" voltage reference node or connected to the circuit for portions of energy leaving the interposer **30** to an external connection (not shown) that serves as the low impedance pathway return. Interposer **30** also comprises differential electrode termination bands **330** corresponding to the first differential electrode **303** and termination bands **340** corresponding to the second differential electrode **305**. Differential electrode termination bands **330** and **340** are utilized for receiving energy and provide a connection point for connections to energy-utilizing internal loads **370** of the IC die **380**. It should be noted for the sake of depiction herein that interposer **30** is normally physically larger than the active component or IC it is attached to and conditioning energy for.

While there are many IC package pin-outs **350** located around the IC carrier edge **392** for signal in return pathways, there is only one pin-out utilized for energy entry, designated at **391B**, and only one pin-out utilized for energy return, designated at **391A**. The IC package **310** is designed such that multiple power entry points are reduced to one pair of power entry/return pins **391A** and **391B** which are connected to the differential electrode termination bands **340** and **330**, respectively, by bond wires **393A**, **393B** or other conductive pathways, or conventional interconnects. The single power entry portal represented by pins **391A** and **391B** and the proximity of the electrode termination bands **330** and **340** of

interposer **30** to the power entry portal reduces the noise that can enter or exit the integrated circuit and interfere with circuitry both internal or external to the integrated circuit package **310**. The connections are by standard means known in the art such as, but not limited to, wire bond jump wires and the like and is determined by the final application needs of a user.

Turning to FIG. **7**, and cross-sectional views of varied embodiments of FIG. **7**, which are FIG. **8A** and FIG. **8B**, the applicants will move freely between all three drawings explaining interposer **60/61**'s, functions and makeup for the embodiments show herein.

In FIG. **7**, interposer **60/61** is shown in this case a top view depiction and it is quickly noted that in most cases, but not all, the opposite sides view or appearance of interposer **60/61** is approximately the same as is shown in FIG. **7** the top view.

In one embodiment of the present invention, referring now to FIG. **7**, interposer **60/61** comprises vias **63**, **64** and **65**, which provide conductive energy propagation pathway interconnections through a plurality of substrate layers within the body of interposer **60/61** encased in material **6312** and surrounded by conductive material **6309**. This embodiment typically utilizes either a paired path or a three-path configuration. In a paired, or two path configuration, interposer **60/61** utilizes a paired two-way I/O circuit pathway using both VIAS **64** and VIAS **65** for IN energy propagation pathways, while using VIAS **66** for the OUT energy propagation pathways. Circuit reference nodes (not shown) could be found and utilized inside or adjacent to the AOC of interposer **60/61** by a portion of internal conductive pathways (not shown) pre-determined by the user for portions of propagating energy servicing the load or from inside the AOC, depending on exact connection circuitry outside the interposer **60/61**.

A three-way conductive pathway I/O configuration is preferred and uses VIAS **65** for IN energy propagation, VIAS **64** for OUT pathed energy propagation or energy return, and uses the center VIAS **66** as a separate, common energy propagation pathway and reference attachment. VIAS **66** allow portions of energy propagating in either direction between an energy-utilizing load (not shown) and an energy source (not shown) to move to a low impedance energy pathway created within the AOC that can be pathed along externally designated common conductive pathways or areas outside of the AOC that would provide or share voltage potential for the circuitry within the interposer's AOC. This low impedance energy pathway, or area, is created as energy from external pathway circuitry is transferred through differential pathways **60C** and **60D** and continues on to external conductive pathways on either one or multiple sides of interposer **60/61**. Portions of this energy propagating within the AOC of interposer **60/61** propagate to common conductive pathways **6200/6200-IM**, **6201**, **6202**, **6203** and **6204/6204-IM** and VIAS **66**, which interconnects the common conductive pathways within the AOC of **60** in this case and allows the energy to propagate along to external common conductive pathways.

Depending on usage, there are some embodiment variations of interposer **61/60** not depicted in FIG. **8B** and FIG. **8A**, but are easily contemplated by the applicants that would have an IC mounting side only, with vias **64,65,66** configured to that shown in FIG. **7**. Yet, depending on the external pathway connections that are to be made or utilized, a variant of interposer **60**, an alternative invention interposer might only comprise one, two or three of the **64,65,66**

conductive via groups with the same or alternate couplings to the perpendicularly disposed internal horizontal conductive pathways such as common pathways **6200/6200-IM**, **6201,6202**, **6203** and **6204/6204-IM**, **60C** and **60D**.

FIG. **8B** shows the common conductive via pathways **66** penetrating completely through to the opposing side **6312**, yet a simple 2 way pathway configuration could utilize all **64** and **65** configured vias, (no via **66** penetrating to the opposing side **6312**, but coupling just to the common pathways **6200/6200-IM**, **6201,6202**, **6203** and **6204/6204-IM**, created) as just energy input pathways, while using the side conductive pathway **6308** created by the joining of common pathways **6200/6200-IM**, **6201,6202**, **6203** and **6204/6204-IM** at **6308** as a return energy path, passing through from the vias **66** located as shown in FIG. **7** and moving through the internal AOC of device **60** and finally propagating outside the internal AOC of device **60** as portions of the energy return to its source by externally attached conductive pathways (not shown) such as wire bondings made to material **6308** or conductive attachment nodes (not shown). It should also be noted that dotted line **60E** represents interposer embodiment **61** or similar boundary or demarcation line of its non-penetrating configuration of common conductive pathways **6200/6200-IM**, **6201, 6202**, **6203** and **6204/6204-IM** that do not make a conductive attachment within to **6309** located on **6312S** portions of interposers **60** & **61** and make coupling connections only to vias **66** as shown in FIG. **8A**, and not to material **6308** as is shown for common conductive pathway electrodes **6200/6200-IM**, **6201,6202**, **6203** and **6204/6204-IM** in FIG. **8B** of interposer **60**. In interposer **61** it must be emphasized that the common conductive pathway electrodes **6200/6200-IM**, **6201,6202**, **6203** and **6204/6204-IM** do not penetrate material dielectric or insulative **6209** and emerge out to **6312S** of this embodiment to join with conductive material **6309** that is applied on interposer embodiment **60** as shown on FIG. **8B**. However, these common conductive pathway electrodes **6200/6200-IM**, **6201,6202**, **6203** and **6204/6204-IM** still extend closer to **6312-S** than do the **60D** and **60C** differential pathways as demarcated or delineated by dotted line **60F** in FIG. **7**. Because of this positioning of the differential and common pathways to one another interposers of the new invention will partake in the electrostatic shielding functions attributed to these types of pathway configurations, many of which are similarly described in detail within this disclosure.

These various pathway configurations reveal the versatility of the device and the that while the common conductive pathways **6200/6200-IM**, **6201,6202**, **6203** and **6204/6204-IM** appear to have a limited positioning criteria, it must be noted that pathway vias **64,65,66** are much more flexible and versatile in positioning configurations, shape, sizes, and can be utilized to provide all sorts of energy conditioning functions and pathway configurations as one in the art or not can dream up. Interposer **60/61** is configured in a way that uses a multi-aperture, multilayer energy conditioning pathway sets and substrate embodiment in a substrate format for conditioning propagating energy along pathways servicing an active element such as, but not limited to, an integrated circuit chip or chips. Interposer **60/61** conditions propagating energy by utilizing a combined energy conditioning methodology of conductively filled apertures known in the art as VIAs, in combination with a multi-layer common conductive Faraday cage-like shielding technology with partially enveloped differential conductive electrodes or pathways. Interconnection of the substrate to the IC and to a mounting structure is contemplated with either wire bonding interconnection, flip-chip ball-grid array

interconnections, microBall-grid interconnections, combinations thereof, or any other standard industry accepted methodologies.

As shown in FIG. **7** and **8B**, conductive material **6309** can be applied or deposited on side **6312S** of Interposer **60** and can be utilized as an auxiliary energy return pathway. At energization, common conductive pathways **6200/6200-IM**, **6201**, **6202**, **6203**, **6204/6204-IM**, VIAs **66**, all shown in FIG. **8B**, will form a path of least impedance with respect to the higher impedance pathways located along differential conductive pathways **60C** and **60D** as well as VIAs **65** or **64**.

Thus, when energized, common conductive pathways **6200/6200-IM**, **6201**, **6202**, **6203**, **6204/6204-IM**, VIAs **66** all shown in FIG. **8B** and FIG. **8A** are utilized as the "0" Voltage circuit reference node (not shown) found both inside and outside the common conductive interposer energy pathway configurations (not shown) as the interposer is electrically positioned in an energized circuit.

Interposer **60** is connected to an integrated circuit **4100** by commonly accepted industry connection methods. On one side of interposer **60**, the various differentially conductive pathways including vias **65** are electrically connected between the energy source (not shown) and a load (not shown) and the various differentially conductive pathways including vias **64** are connected by common industry means between the energy utilizing load (not shown) and the energy source (not shown) on a return pathway that includes conductive pathway vias **66** for portions of propagating energy. It is understood in the art that vias **65** and **64** poses no polarity charge before hook-up that would prevent each from changing energy propagation functions such as from Input to an output function as long as consistency in species hook up is maintained, once initiated on the device.

FIG. **8A** shows interposer **61** taken from a cross sectional view "A" of a main embodiment of energy conditioning interposer taken from FIG. **7** surrounded by non conductive exterior surface **6312**. Interposer **61** comprises conductive differential energy pathway electrode **60-C** that is coupled to conductive VIA pathway **64** and conductive differential energy pathway electrode **60-D** that is coupled to conductive VIA pathway **65**, each as designated at **6205** by standard industry known means. Differential energy pathway **60-C** and differential energy pathway **60-D** are separated from each other by central, shared, common conductive energy pathway **6202** and from the top and bottom of the interposer **61** by common conductive energy pathways **6200/6200-IM**, **6201**, and **6203**, **6204/6204-IM**, respectively. The common conductive energy pathways **6200/6200-IM**, **6201**, **6202**, **6203**, and **6204/6204-IM**, are interconnected by conductive VIA pathway **66** as designated at **6308** by standard industry known means. The outer most common conductive energy pathways **6200/6200-IM** and **6204/6204-IM** act as image shield electrodes and are vertically spaced from their adjacent common conductive energy pathways **6201**, **6203**, respectively, as designated by **4011**. Conductive via pathways **64**, **65**, and **66** are selectively isolated in a predetermined manner from common conductive energy pathways and differential conductive pathways by a gap **6307** which is space filled with dielectric medium or isolative or insulating material and can either be an actual deposited material or simply a void of conductive material that would prevent coupling of the various conductive interposer pathways.

It should be noted that conductive via pathways **64**, **65** passes through the various conductive and dielectric material and is selectively coupled to interposer **61**'s conductive differential energy pathway electrodes as needed by the user.

VIA **64** and **65** can be chosen to receive energy input, either output or image pathway duties as needed with via **66**. Conductive VIA pathways **64**, **65**, and **66** are electrically connected to external elements as previously discussed. These connections can be any industry-accepted type of connection. As shown in FIGS. **8A** and **8B**, a connection is made by applying adhesive or solder ball flux **4005**, or an industry accepted contact material the of the for conductive seating pad **63** for gravity or adhesive placement processing using solder balls **4007** which is a eutectic-type solder ball or industry standard equivalent.

Now turning to FIG. **8B**, interposer **60** is shown identical to that interposer **61** shown in FIG. **8A** except that common conductive edge termination material **6309** extends along the sides of the interposer and surrounds the perimeter thereof as shown previously in FIG. **7**. Also note that common conductive edge termination material **6309** is electrically connected to common conductive energy conditioning pathways **6200/6200-IM**, **6201**, **6202**, **6203** and **6204/6204-IM** and not done in FIG. **8A**. Interposer **60** is also shown connected to an integrated circuit die **4100**. The integrated circuit die **4100** is also shown with protective glob coating or encapsulment material **6212** just above the die surface. The energy conditioning interposer **60** is also mounted on a substrate **8007** or substrates to which the IC assembly will be attached either by ball grids **8009** and **8010** or by other means commonly used in the industry. The IC package pins **8009** provide interconnection to a substrate or socket connector containing signal and ground connections not necessarily going to interposer pathways, while **8010** pathway connections although not shown, could connect to interposer pathways for energy propagation. It should be noted that **4011** is the predetermined layering used or pathway spacing that is part of the invention consideration, universally. These interconnections are only to offer that they can be varied as to any standard industry means of connecting an IC package to a PCB, PCB card and the like. In the cases of MCM or SCM interconnections, interposer **60** or **61** can be directly attached to substrate circuitry with standard industry methodologies.

In FIG. **9**, a close up of a portion of FIG. **8A** reveals some of the actual external interconnecting elements for the VIA structures **64,65,66**. It should be noted that the internal conductive pathways are typical but the coupling points are not shown herein. On-conductive material **6209** is also called out. Conductive capture pad **63** is disposed on one side of the non-conductive portion **6312** of the interposer **61** around conductive pathway via **66**, which comprises a small diameter shaped pathway of conductive material **66A** that is selectively coupled **6308** or non-coupled **6307** by standard means known in the art, either after vias are created either by a laser or drilling process that leaves a void for filling with material **66'** during the manufacturing process or at the same time deposit of **66'** is made that couples **6308** to common conductive pathways **6200/6200-IM**, **6201**, **6202**, **6203** and **6204/6204-IM** as shown in FIG. **8A**. A capture pad **63** is also formed on the opposite side opening of the non-conductive material **6312** of the interposer **61** that coincides with conductive pathway via **66** leading to conductive capture pad **63** which is also deposited on the bottom of interposer **61**. An adhesive solder ball flux an industry accepted contact material or primer **4005** is then applied and subsequently followed by application of conductive solder ball **4007** of the type commonly found in the art.

It is important to note that the actual manufacturing process used to make an invention embodiment **60** or **61** and subsequently attach it to an active chip, chips or IC and than

to a mounting substrate can be accomplished in many ways. Rather FIG. **9** is an attempt to merely outline, in general terms, some of the many mounting procedures and connection materials that can be used, added, removed or are interchangeable and widely varied from manufacturer to manufacturer. Attachment materials and methodologies, overall for interposer invention described herein are not limited in any way. The critical nature of invention functionality, rather is simply determined more on the actual attachment arrangements made for the differently grouped, common conductive pathways and the differential conductive pathways to the external conductive pathways respectively, located outside the AOC that are key elements so long as energy pathways are conductively nominal for energy propagation.

Referring now to FIG. **10**, the exterior, or underside of a prior art IC package is shown using an assembly of externally mounted, multiple low inductance capacitive devices **8001** utilized in a prior art configuration with the internally located prior art interposer. The IC package exterior **8007** is a standard configuration where pin outs emerge from one portion of the device for attachment to a mounting substrate, PCB or daughter card assembly, while other energy pathways utilize either combinations of ball grid sockets **8006** and pin outs or simply sockets **8006** while conductive pin-outs are used by other pathways such as signal lines, for example or other standard means used in the industry. Ball grid sockets **8004** are typically comprised for receipt of eutectic solder or the like and are typically configured around the inner region of the IC package **8002** rather than the exterior regions of **8007** to be closer for energy delivery to the internally mounted active chip or IC (not shown). The ball grid sockets **8004** are located within a perimeter or outline **8003** of the internal area location of the IC and interposer within the IC package **8007** as designated. Within the perimeter outline, ball grid sockets **8004** for interconnection are normally for energy supplying power by the I/O pathways **8005** of the IC package **8007**. This prior art IC package is intended to show that the internally positioned prior art interposer (not shown) requires an assembly **8001** of low inductance capacitive array chip device in location **8002** to function properly.

In contrast, referring now to FIG. **11**, the exterior, or underside of an IC package **8007** is utilizing an embodiment of the present invention mounted inside IC package **8007** as is shown, "ghosted" for ease of description. As before, the perimeter outline **8003** designates the location of the IC and interposer **8006** within the IC package **8007** and the perimeter is surrounded by ball grid sockets **8004**. The mounted multi-aperture energy conditioning architecture device **60-61** or similar is shown as a interposer located between the integrated circuit or IC assembly (not shown) and the mounting substrate or in this depiction the mounting substrate used is the final layering or groups of layering making up the outside portion of substrate package **8007**. It should be noted that interposer **60-61** or similar can also be utilized to provide for an additional physical shielding function utilized by the active IC chip or chips connected to said interposer as well as it also provides the simultaneous energy conditioning functions as described in the disclosure. Shielding of this nature is accomplished by interposers mere presence in the package as long as the active chip (not shown) does not have portions of its embodiment extending beyond the perimeter of interposer invention. Device **60** includes apertures **64** connected to internal energy conditioning electrode(s) **60C** and apertures **65** connected to internal energy conditioning electrode(s) **60D**. Conductive

apertures 66 are connected to common conductive pathways 6200/6200-IM, 6201, 6202, 6203, and 6204/6204-IM or any additional pathways of the similar use that are utilized.

It should be noted that in all embodiments, it is optional but preferred that one set of outer common conductive pathways or layers designated as -IM should sandwich the entire stacking configuration, either placed in the manufacturing process of the entire device, perhaps utilized from part of the mounting substrate serving as a platform other than a discrete IC package or the IC package itself or even by utilizing an external conductive pathway or larger external conductive area, alone or with insulating material disposed between to take the place of at least one of the two outer common conductive pathways designated -IM. The prime set of outer common conductive pathways not designated as -IM and closely positioned to the described set of outer are critical to the device as the common conductive pathways that form the basis of the sidelining electrode sandwich and can only be made optional in cases where the final shield is replaced or substituted with an external conductive area that can fit most of the criteria described to allow the faraday cage-like shield structure to maintain integrity with respect to the energy conditioning functions desired. However in the case of the -IM designated shields they are optional yet desirable in that they will electrically enhance circuit conditioning performance and further shift outward the new interposers' self resonate point and enhance that portion of the circuit located within the AOC of the invention, as well.

It should be noted that if the common conductive container structures that make up an invention are in balance according to the result of the stacking sequence as described herein, any added or extra, single common conductive shield layers designated -IM beyond the primary set of common conductive pathways that are added by mistake or with forethought will not degrade energy conditioning operations severely and this condition in some cases can actually reveal a potential cost savings in the manufacturing process, wherein automated layering processes could possibly add one or more additional outer layer or layers as described and where the application performance may not be as critical.

It is disclosed that these errors, intentional or accidental will not detrimentally harm the balance of the invention containing the minimum properly sequenced stacking of common conductive pathways as discussed and is fully contemplated by the applicants.

At least five or more, distinctly different energy conditioning functions that can occur within any variation of the invention; electrostatic minimization of energy parasitics by almost total shield envelopment; a physical shielding of portions of the differential conductive pathways; an electromagnetic cancellation or minimization shielding function or mutual magnetic flux cancellation or minimization of opposing, closely positioned, differential conductive pathway pairs; utilization of a "0" voltage reference created by the central, common and shared pathway electrode, the sandwiching outer first set of common conductive pathways and any of the -IM designated pathways that are utilized as part of two distinct common conductive shield structure containers; a parallel propagation movement of portions of energy providing a shielding effect as opposed to a series propagation movement of energy effect of the portions of energy located within the AOC. A parallel propagation movement of portions of energy occurs when differentially phased energy portions operate in an opposing, yet harmonious fashion with said energies divide such that approximately ½ half of the total energies or portions found at any onetime within the AOC of the invention will be located on

one side of the central common and shared conductive energy pathway in a electrical and/or magnetic operation utilizing its parallel, non-reinforcing counterpart that operates in a generally opposing cancellation or minimization-type manner or in a manner that does not enhance or create detrimental forces in a manner like that of the prior art which operates in a generally series-type manner despite the usage in a few cases of a mutual magnetic flux cancellation or minimization technique of opposing differential conductive pathway. Prior art due to its structure all but fails to utilize the simultaneous sandwiching electrostatic shielding function inherent in the new invention as has been described in this disclosure.

In all embodiments whether shown or not, the number of pathways, both common conductive pathway electrodes and differential conductive pathway electrodes, can be multiplied in a predetermined manner to create a number of conductive pathway element combinations a generally physical parallel relationship that also be considered electrically parallel in relationship with respect to these elements in an energized existence with respect to a circuit source will exist additionally in parallel which thereby add to create increased capacitance values.

Next, additional common conductive pathways surrounding the combination of a center conductive pathway and a plurality of conductive electrodes are employed to provide an increased inherent common conductive pathway and optimized Faraday cage-like function and surge dissipation area in all embodiments.

Fourth, although a minimum of one central common conductive shield paired with two additionally positioned and sandwiching common conductive pathways or shields are generally desired and should be positioned on opposite sides of the central common conductive shield (other elements such as dielectric material and differential conductive electrode pairs, each positioned on opposite sides of said central common layer can be located between these shields as described). Additional common conductive pathways can be employed such as the -IM designated shields that do not have a differential conductive pathway adjacent to its position with any of the embodiments shown and is fully contemplated by Applicant.

Finally, from a review of the numerous embodiments it should be apparent that the shape, thickness or size may be varied depending on the electrical characteristics desired or upon the application in which the filter is to be used due to the physical architecture derived from the arrangement of common conductive electrode pathways and their attachment structures that form at least one single conductively homogenous Faraday cage-like conductive shield structure with conductive electrode pathways.

Although the principals, preferred embodiments and preferred operation of the present invention have been described in detail herein, this is not to be construed as being limited to the particular illustrative forms disclosed. It will thus become apparent to those skilled in the art that various modifications of the preferred embodiments herein can be made without departing from the spirit or scope of the invention as defined by the appended claims.

What is claimed is:

1. An energy conditioning interposer component assembly comprising:

a plurality of common electrodes each having a plurality of conductive apertures there through, wherein said plurality of common electrodes comprises at least a central common electrode, a first common electrode, and a second common electrode;

at least one pair of differential electrodes each having a plurality of conductive apertures there through, wherein said at least one pair of differential electrodes comprises at least a first differential electrode and a second differential electrode;

wherein said first differential electrode is stacked above said central common electrode and said second differential electrode is stacked below said central common electrode, wherein said first differential electrode and said second differential electrode sandwich said central common electrode;

wherein said first common electrode is stacked above said first differential electrode and said second common electrode is stacked below said second differential electrode;

a material having predetermined electrical properties, wherein said material is maintained between said plurality of common electrodes and said first and second differential electrodes preventing direct electrical connection between said plurality of common electrodes and said first and second differential electrodes;

wherein said first differential electrode is electrically connected to a first conductive aperture of said a plurality of conductive apertures wherein said first conductive aperture provides an electrical connection to an external electrical circuit and wherein said first conductive aperture is insulated from said second differential electrode and said plurality of common electrodes;

wherein said second differential electrode is electrically connected to a second conductive aperture of said a plurality of conductive apertures wherein said second conductive aperture provides an electrical connection to an external electrical circuit and wherein said second conductive aperture is insulated from said first differential electrode and said plurality of common electrodes;

wherein said plurality of common electrodes are electrically interconnected to a third conductive aperture of said a plurality of conductive apertures wherein said third conductive aperture is insulated from said first differential electrode and said second differential electrode; and

said plurality of common electrodes and said at least one pair of differential electrodes form a plurality of energy conditioning elements.

**2.** An energy conditioning interposer circuit assembly comprising:

a plurality of common electrodes, wherein said plurality of common electrodes comprises at least a central common electrode, a first common electrode, and a second common electrode;

at least one pair of differential electrodes, wherein said at least one pair of differential electrodes comprises at least a first differential electrode and a second differential electrode;

wherein said first differential electrode is stacked above said central common electrode and said second differential electrode is stacked below said central common electrode, wherein said first differential electrode and said second differential electrode sandwich said central common electrode;

wherein said first common electrode is stacked above said first differential electrode and said second common electrode is stacked below said second differential electrode;

wherein said first differential electrode and said second differential electrode include a plurality of electrode termination extensions protruding through an insulation band extending about the perimeter of each electrode, wherein said electrode termination extensions provide an area for conductive attachment to an external energy utilizing circuit; and

said plurality of common electrodes and said at least one pair of differential electrodes form a plurality of energy conditioning elements.

**3.** The energy conditioning interposer component assembly as recited in claim **1**, further comprising at least an integrated circuit for conductive connection.

**4.** The energy conditioning interposer component assembly as recited in claim **1**, where in the ratio of said common electrodes to said differential electrodes is 3:2.

**5.** An energy conditioning interposer for energized circuitry comprising:

means for simultaneously conditioning differential and common mode energy;

means for decoupling differential and common mode energy; and

means for partially suppressing internally generated energy parasitics from said circuit conditioning electronic component.

**6.** The energy conditioning interposer for energized circuitry as recited in claim **5**, further comprising means for simultaneously preventing radiation of portions of energy from said energy conditioning interposer while shielding said energy conditioning interposer conditioning means from external electrical noise.

**7.** The energy conditioning interposer for energized circuitry as recited in claim **5**, further comprising means for simultaneously shielding said energy conditioning interposer from external electrical noise while reducing mutual inductive coupling between said first and second differential electrodes.

**8.** The energy conditioning interposer circuit assembly as recited in claim **2** comprising:

means for simultaneously conditioning differential and common mode energy;

means for decoupling differential and common mode energy; and

means for partially suppressing internally generated energy parasitics from said at least one pair of differential electrodes.

**9.** The energy conditioning interposer circuit assembly as recited in claim **8**, further comprising means for increasing minimization of portions of opposed energy flux fields between said at least one pair of differential electrodes.

**10.** The energy conditioning interposer circuit assembly as recited in claim **8**, further comprising:

means for minimizing internal electrical noise of said at least one pair of differential electrodes;

wherein said minimization of internal electrical noise provides a low impedance pathway along said central common electrode and either said first or said second common electrodes; and

wherein said low impedance pathway at least partially surrounds one differential electrode of said at least one pair of differential electrodes.

**11.** A circuit assembly comprising:

an integrated circuit package including an integrated circuit die;

an energy conditioning interposer comprising a first and second differential conductive energy pathway, a plu-

rality of common conductive energy pathways, wherein said at least one of said plurality of common conductive energy pathways is positioned above and below each of said first and second differential conductive energy pathways, and wherein said plurality of common conductive energy pathways are electrically interconnected and connected to a metalized portion of said integrated circuit package;

at least one internal energy utilizing load electrically connected to said first and second differential conductive energy pathways;

wherein said plurality of common conductive energy pathways and said first and second differential conductive pathways form a plurality of energy conditioning elements.

**12.** A circuit assembly comprising:

at least one integrated circuit chip;

an energy conditioning interposer interconnected to said circuit chip comprising a plurality of substrate layers wherein said plurality of substrate layers are formed in a parallel relationship and include a plurality of interconnected common conductive electrodes, a plurality of differential conductive electrodes; said interposer further comprising a plurality of conductive energy pathways formed generally perpendicular to said plurality of substrate layers, wherein said plurality of conductive energy pathways provide electrical connection to one or more of said plurality of substrate layers and when energized completes a portion of a system circuitry wherein said plurality substrate layers of form a plurality of energy conditioning elements.

**13.** The circuit assembly as recited in claim **12**, wherein the ratio of said common conductive electrodes to said differential conductive electrodes is 3:2.

**14.** The circuit assembly as recited in claim **12**, wherein said interposer further comprises means for simultaneously conditioning differential and common mode energy;

means for decoupling differential and common mode energy; and

means for partially suppressing internally generated energy parasitics from said interposer.

**15.** The circuit assembly as recited in claim **12**, wherein said interposer further comprises means for simultaneously preventing radiation of portions of energy from said interposer while shielding said interposer from external electrical noise.

**16.** The circuit assembly as recited in claim **12**, further comprising means for simultaneously shielding said interposer from external electrical noise while reducing mutual inductive coupling between said first and second differential conductive electrodes.

**17.** An energy conditioning interposer assembly comprising:

at least one pair a differential conductive electrodes each having at least two conductive apertures therethrough;

at least three common conductive electrodes each having at least two conductive apertures therethrough;

wherein each differential conductive electrode is sandwiched by an upper and a lower common conductive electrode;

wherein each differential conductive electrode and each common conductive electrode is positioned within said interposer in a generally parallel and stacked orientation and electrically insulated from each other by a dielectric material; and

an outer conductive side surface electrically connected to each said common conductive electrode such that each said differential conductive electrode is shielded by said common conductive electrodes and said outer conductive side surface through which conductive pathways oriented generally perpendicular to said differential conductive electrode provide connection to an external electrical circuit through said at least two conductive apertures;

wherein said common conductive electrodes, said outer conductive side surface, and said at least one pair of differential electrodes form a plurality of energy conditioning elements.

**18.** The energy conditioning interposer assembly as recited in claim **17**, wherein at least a first conductive aperture of said at least two conductive apertures is electrically connected to a first differential electrode of said at least one pair of differential electrodes, wherein at least a second conductive aperture of said at least two conductive apertures is electrically connected to a second differential electrode of said at least one pair of differential electrodes.

**19.** The energy conditioning interposer assembly as recited in claim **17**, wherein said common conductive electrodes and said differential electrodes each include at least three conductive apertures therethrough, wherein at least a first conductive aperture of said at least three conductive apertures is electrically connected to a first differential electrode of said at least one pair of differential electrodes, wherein at least a second conductive aperture of said at least three conductive apertures is electrically connected to a second differential electrode of said at least one pair of differential electrodes, and wherein at least a third conductive aperture of said at least three conductive apertures is electrically connected to each common conductive electrode.

**20.** The energy conditioning interposer component assembly of claim **1** in which said plurality of common electrodes further comprises at least a third common electrode and at least a fourth common electrode; and

wherein said at least a third common electrode is stacked above said first common electrode and said at least a fourth common electrode is stacked below said second common electrode.

**21.** The energy conditioning interposer component assembly of claim **1** in which each common electrode of said plurality of common electrodes is electrically interconnected to at least a fourth conductive aperture of said plurality of conductive apertures, and wherein said fourth conductive aperture is insulated from said first differential electrode and said second differential electrode of said at least one pair of differential electrodes.

**22.** The energy conditioning interposer component assembly of claim **21** in which the total sum of said conductive apertures of said plurality of conductive apertures within said energy conditioning interposer component assembly is an even integer.

**23.** The energy conditioning interposer component assembly of claim **1** in which the total sum of said differential electrodes of said at least one pair of differential electrodes and of said common electrodes of said plurality of common electrodes within said energy conditioning interposer component assembly is an odd integer.

**24.** The energy conditioning interposer component assembly of claim **1** in which each conductive aperture of said plurality of conductive apertures is a conductive via.

**25.** The energy conditioning interposer component assembly of claim **1** in which each common electrode of said

plurality of common electrodes share a common perimeter edge alignment.

26. The energy conditioning interposer component assembly of claim 20 in which each common electrode of said plurality of common electrodes share a common perimeter edge alignment.

27. The energy conditioning interposer component assembly of claim 1 in which said first differential electrode of said at least one pair of differential electrodes is practicable to be both electrically and physically complementary to said second differential electrode of said at least one pair of differential electrodes when energized.

28. The energy conditioning interposer component assembly of claim 26 in which at least two selected common electrodes of said plurality of common electrodes are practicable to at least partially electrostatically shield each differential electrode of said at least one pair of differential electrodes.

29. The energy conditioning interposer component assembly of claim 1 in which at least two selected common electrodes of said plurality of common electrodes are practicable to at least partially electrostatically shield each differential electrode of said at least one pair of differential electrodes.

30. The energy conditioning interposer component assembly of claim 1 in which each differential electrode of said at least one pair of differential electrodes are physically complementary to each other.

31. The energy conditioning interposer component assembly of claim 1 in which each differential electrode of said at least one pair of differential electrodes is generally smaller than any one common electrode of said plurality of common electrodes.

32. The energy conditioning interposer component assembly of claim 1 in which said energy conditioning interposer component assembly is arranged within at least an integrated circuit package assembly.

33. The energy conditioning interposer component assembly of claim 1 in which said material having predetermined electrical properties is at least a dielectric material.

34. The energy conditioning interposer component assembly of claim 1 in which said energy conditioning interposer component assembly is arranged to define at least a common mode and differential mode filter network.

35. The energy conditioning interposer component assembly of claim 1 in which said energy conditioning interposer component assembly is arranged to define at least a decoupling capacitor.

36. The energy conditioning interposer component assembly of claim 1 in which said energy conditioning interposer component assembly is arranged to define a voltage divider for energized operations.

37. The energy conditioning interposer component assembly of claim 1 in which said energy conditioning interposer component assembly is arranged to define at least a bypass capacitor.

38. The energy conditioning interposer component assembly of claim 1 in which said energy conditioning interposer component assembly is arranged to define at least a feed-thru capacitor.

39. The energy conditioning interposer assembly of claim 17, wherein the total sum of said conductive apertures within said energy conditioning interposer assembly is an even integer.

40. The energy conditioning interposer assembly of claim 17 in which each conductive aperture of said at least two conductive apertures is a conductive via.

41. The circuit assembly of claim 12, wherein the total sum of said substrate layers within said circuit assembly is an even integer.

42. The circuit assembly of claim 12 in which each said substrate layer within said circuit assembly comprises at least a dielectric material.

43. The energy conditioning interposer assembly of claim 12 in which each said substrate layer within said circuit assembly share a common perimeter edge alignment.

44. The energy conditioning interposer assembly of claim 17 in which each common electrode of said at least three common electrodes share a common perimeter edge alignment.

45. The energy conditioning interposer assembly of claim 17 in which said first differential electrode of said at least one pair of differential electrodes is operable to be electrically complementary to said second differential electrode of said at least one pair of differential electrodes.

46. The energy conditioning interposer assembly of claim 17 in which at least two selected common electrodes of said at least three common electrodes are practicable to at least partially electrostatically shield each differential electrode of said at least one pair of differential electrodes.

47. The energy conditioning interposer assembly of claim 17 in which the differential electrodes of said at least one pair of differential electrodes are physically complementary to each other.

48. The energy conditioning interposer assembly of claim 17 in which each differential electrode of said at least one pair of differential electrodes is generally smaller than any one common electrode of said at least three common electrodes.

49. The energy conditioning interposer assembly of claim 17 in which the total sum of said at least one pair of differential electrodes and said common electrodes of said energy conditioning interposer component assembly is an odd integer.

50. The energy conditioning interposer assembly of claim 17 in which said energy conditioning interposer assembly is arranged within at least an integrated circuit package assembly.

51. The energy conditioning interposer assembly of claim 19 in which said energy conditioning interposer assembly is arranged to define at least a common mode and differential mode filter network.

52. The circuit assembly of claim 12 in which said circuit assembly is arranged to define at least a decoupling capacitor.

53. The circuit assembly of claim 12 in which said circuit assembly is arranged to define a voltage divider for energized operations.

54. The circuit assembly of claim 12 in which said circuit assembly is arranged to define at least a bypass capacitor.

55. The circuit assembly of claim 12 in which said circuit assembly is arranged to define at least a feed-thru capacitor.

56. The energy conditioning interposer circuit assembly of claim 2 in which said plurality of common electrodes share a common perimeter edge alignment.

57. The energy conditioning interposer circuit assembly of claim 56 in which said plurality of common electrodes are conductively coupled to one another.

58. The energy conditioning interposer circuit assembly of claim 2 in which said first differential electrode of said at least one pair of differential electrodes is operable to be electrically complementary to said second differential electrode of said at least one pair of differential electrodes..

59. The energy conditioning interposer circuit assembly of claim 2 in which the differential electrodes of said at least



one pair of differential electrodes is physically complementary to each other.

60. The energy conditioning interposer circuit assembly of claim 2 in which each differential electrode of said at least one pair of differential electrodes is generally smaller than any one common electrode of said plurality of common electrodes.

61. The energy conditioning interposer circuit assembly of claim 2 in which at least two selected common electrodes of said plurality of common electrodes are practicable to at least partially electrostatically shield each differential electrode of said at least one pair of differential electrodes.

62. The energy conditioning interposer circuit assembly of claim 2 in which the total sum of said differential electrodes of said at least one pair of differential electrodes and of said common electrodes of said plurality of common electrodes found within said energy conditioning interposer circuit assembly is an odd integer.

63. The energy conditioning interposer circuit assembly of claim 2 in which said energy conditioning interposer circuit assembly is arranged within at least an integrated circuit package.

64. The energy conditioning interposer circuit assembly of claim 57, further comprising a material having predetermined electrical properties, and wherein said material is maintained between said plurality of common electrodes and said first differential electrode of said at least one pair of differential electrodes and said second differential electrode of said at least one pair of differential electrodes preventing electrical coupling between said plurality of common electrodes and said first differential electrode of said at least one pair of differential electrodes and second differential electrode of said at least one pair of differential electrodes.

65. The energy conditioning interposer circuit assembly of claim 64 in which said material having predetermined electrical properties is at least a dielectric material.

66. The energy conditioning interposer circuit assembly of claim 65 in which said energy conditioning interposer circuit assembly is arranged to define at least a common mode and differential mode filter network.

67. The energy conditioning interposer circuit assembly of claim 64 in which said energy conditioning interposer circuit assembly is arranged to define at least a decoupling capacitor.

68. The energy conditioning interposer circuit assembly of claim 64 in which said energy conditioning interposer circuit assembly is arranged to define a voltage divider for energized operations.

69. The energy conditioning interposer circuit assembly of claim 2 in which said energy conditioning interposer circuit assembly is arranged to define at least a bypass capacitor.

70. The energy conditioning interposer circuit assembly of claim 2 in which said energy conditioning interposer circuit assembly is arranged to define at least a feed-thru capacitor.

71. The energy conditioning interposer circuit assembly of claim 2 in which each common electrode of said plurality of common electrodes is generally the same size to each other.

72. The energy conditioning interposer circuit assembly of claim 2 in which the differential electrodes of said at least one pair of differential electrodes are physically complementary to each other.

73. The energy conditioning interposer circuit assembly of claim 2 in which each differential electrode of said at least one pair of differential electrodes is generally smaller than any one common electrode of said plurality of common electrodes.

\* \* \* \* \*

UNITED STATES PATENT AND TRADEMARK OFFICE  
**CERTIFICATE OF CORRECTION**

PATENT NO. : 6,738,249 B1  
APPLICATION NO. : 09/632048  
DATED : May 18, 2004  
INVENTOR(S) : Anthony et al.

Page 1 of 3

It is certified that error appears in the above-identified patent and that said Letters Patent is hereby corrected as shown below:

On the title page, item 63, as corrected by the certificate of correction filed May 27, 2004, which reads "Continuation-in-part of application No. 09/600,530, filed on July 18, 2000, which is a US national stage application of international application PCT/US99/01040 filed January 16, 1999; this application is also a continuation-in-part of co-pending application Ser. No. 09/594,447 filed Jun. 15, 2000, which is a continuation-in-part of co-pending application Ser. No. 09/579,606 filed May 26, 2000, which is a continuation-in-part of co-pending application Ser. No. 09/460,218 filed Dec. 13, 1999, which is a continuation of application Ser. No. 09/056,379 filed Apr. 7, 1998, now issued as U.S. Pat. No. 6,018,448, which is a continuation-in-part of application Ser. No. 09/008,769 filed Jan. 19, 1998, now issued as U.S. Pat. No. 6,097,581, which is a continuation-in-part of application Ser. No. 08/841,940 filed Apr. 8." should read:

--Continuation-in-part of application No. 09/600,530, now U.S. Pat. No. 6,498,710, filed on July 18, 2000, which is a US national stage application of international application PCT/US99/01040 filed January 16, 1999, which is a continuation in part of application Ser. No. 09/056,379 filed Apr. 7, 1998, now U.S. Pat. No. 6,018,448, which is a continuation-in-part of application Ser. No. 09/008,769 filed Jan. 19, 1998, now U.S. Pat. No. 6,097,581, which is a continuation-in-part of application Ser. No. 08/841,940 filed Apr. 8, 1997, now U.S. Pat. No. 5,909,350; this application is also a continuation-in-part of co-pending application Ser. No. 09/594,447 filed Jun. 15, 2000, which is a continuation-in-part of co-pending application Ser. No. 09/579,606 filed May 26, 2000, which is a continuation-in-part of co-pending application Ser. No. 09/460,218 filed Dec. 13, 1999, which is a continuation of application Ser. No. 09/056,379 filed Apr. 7, 1998, now issued as U.S. Pat. No. 6,018,448, which is a continuation-in-part of application Ser. No. 09/008,769 filed Jan. 19, 1998, now issued as U.S. Pat. No. 6,097,581, which is a continuation-in-part of application Ser. No. 08/841,940 filed Apr. 8, 1997, now U.S. Pat. 5,909,350; and application 09/594,447 is also a continuation-in-part of application No. 09/600,530, now U.S. Pat. No. 6,498,710, filed on July 18, 2000, which is a US national stage application of international application PCT/US99/01040 filed January 16, 1999, which is a continuation in part of application Ser. No. 09/056,379 filed Apr. 7, 1998, now U.S. Pat. No. 6,018,448, which is a continuation-in-part of application Ser. No. 09/008,769 filed Jan. 19, 1998, now U.S. Pat. No. 6,097,581, which is a continuation-in-part of application Ser. No. 08/841,940 filed Apr. 8, 1997, now U.S. Pat. No. 5,909,350; and application 09/579,606 is also a continuation-in-part of application No. 09/600,530, now U.S. Pat. No. 6,498,710, filed on July 18, 2000, which is a US national stage application of international application PCT/US99/01040 filed January 16, 1999, which is a continuation in part of application Ser. No. 09/056,379 filed Apr. 7, 1998, now U.S. Pat. No. 6,018,448, which is a continuation-in-part of application Ser. No. 09/008,769 filed Jan. 19, 1998, now U.S. Pat. No. 6,097,581, which is a continuation-in-part of application Ser. No. 08/841,940 filed Apr. 8, 1997, now U.S. Pat. No. 5,909,350.--

UNITED STATES PATENT AND TRADEMARK OFFICE  
**CERTIFICATE OF CORRECTION**

PATENT NO. : 6,738,249 B1  
APPLICATION NO. : 09/632048  
DATED : May 18, 2004  
INVENTOR(S) : Anthony et al.

Page 2 of 3

It is certified that error appears in the above-identified patent and that said Letters Patent is hereby corrected as shown below:

In the first sentence of the specification, column 1 lines 5-18 as corrected by the Certificate of Correction filed May 27, 2004 reading "This application is a continuation-in-part of co-pending application Ser. No. 09/600,530, filed July 18, 2000, which is a US national stage application of international application PCT/US99/01040 filed January 16, 1999; this application is also a continuation-in-part of co-pending application Ser. No. 09/594,447 filed Jun. 15, 2000, which is a continuation-in-part of co-pending application Ser. No. 09/579,606 filed May 26, 2000, which is a continuation-in-part of co-pending application Ser. No. 09/460,218 filed Dec. 13, 1999, which is a continuation of application Ser. No. 09/056,379 filed Apr. 7, 1998, now issued as U.S. Pat. No. 6,018,448, which is a continuation-in-part of application Ser. No. 09/008,769 filed Jan. 19, 1998, now issued as U.S. Pat. No. 6,097,581, which is a continuation-in-part of application Ser. No. 08/841,940 filed Apr. 8, 1997, now issued as U.S. Pat. No. 5,909,350." should read:

--This application is a continuation-in-part of co-pending application Ser. No. 09/600,530, filed July 18, 2000, now Pat. No. 6,498,710, which is a US national stage application of international application PCT/US99/01040 filed January 16, 1999, which is a continuation in part of application Ser. No. 09/056,379 filed Apr. 7, 1998, now U.S. Pat. No. 6,018,448, which is a continuation-in-part of application Ser. No. 09/008,769 filed Jan. 19, 1998, now U.S. Pat. No. 6,097,581, which is a continuation-in-part of application Ser. No. 08/841,940 filed Apr. 8, 1997, now U.S. Pat. No. 5,909,350; this application is also a continuation-in-part of co-pending application Ser. No. 09/594,447 filed Jun. 15, 2000, now Pat. No. 6,636,406, which is a continuation-in-part of co-pending application Ser. No. 09/579,606, now Pat. No. 6,373,673, filed May 26, 2000, which is a continuation-in-part of co-pending application Ser. No. 09/460,218 filed Dec. 13, 1999, now Pat. No. 6,331,926, which is a continuation of application Ser. No. 09/056,379 filed Apr. 7, 1998, now Pat. No. 6,018,448, which is a continuation-in-part of application Ser. No. 09/008,769 filed Jan. 19, 1998, now Pat. No. 6,097,581, which is a continuation-in-part of application Ser. No. 08/841,940 filed Apr. 8, 1997, now Pat. No. 5,909,350; and application 09/594,447 is also a continuation-in-part of application No. 09/600,530, now U.S. Pat. No. 6,498,710, filed on July 18, 2000, which is a US national stage application of international application PCT/US99/01040 filed January 16, 1999, which is a continuation in part of application Ser. No. 09/056,379 filed Apr. 7, 1998, now U.S. Pat. No. 6,018,448, which is a continuation-in-part of application Ser. No. 09/008,769 filed Jan. 19, 1998, now U.S. Pat. No. 6,097,581, which is a continuation-in-part of application Ser. No. 08/841,940 filed Apr. 8, 1997, now U.S. Pat. No. 5,909,350; and application 09/579,606 is also a continuation-in-part of application No. 09/600,530, now U.S. Pat. No. 6,498,710, filed

UNITED STATES PATENT AND TRADEMARK OFFICE  
**CERTIFICATE OF CORRECTION**

PATENT NO. : 6,738,249 B1  
APPLICATION NO. : 09/632048  
DATED : May 18, 2004  
INVENTOR(S) : Anthony et al.

Page 3 of 3

It is certified that error appears in the above-identified patent and that said Letters Patent is hereby corrected as shown below:

on July 18, 2000, which is a US national stage application of international application PCT/US99/01040 filed January 16, 1999, which is a continuation in part of application Ser. No. 09/056,379 filed Apr. 7, 1998, now U.S. Pat. No. 6,018,448, which is a continuation-in-part of application Ser. No. 09/008,769 filed Jan. 19, 1998, now U.S. Pat. No. 6,097,581, which is a continuation-in-part of application Ser. No. 08/841,940 filed Apr. 8, 1997, now U.S. Pat. No. 5,909,350.--

Signed and Sealed this

Ninth Day of September, 2008

A handwritten signature in black ink that reads "Jon W. Dudas". The signature is written in a cursive style with a large, looped initial "J".

JON W. DUDAS  
*Director of the United States Patent and Trademark Office*