

**UNITED STATES DISTRICT COURT  
MIDDLE DISTRICT OF TENNESSEE  
NASHVILLE DIVISION**

<b>PROTECTIVE INDUSTRIES, INC.,</b>	)	
<b>(d.b.a. CAPPLUGS),</b>	)	
	)	
<b>Plaintiff,</b>	)	
	)	
<b>v.</b>	)	<b>No. 3:10-01033</b>
	)	<b>Judge Sharp</b>
<b>RATERMANN MANUFACTURING,</b>	)	
<b>INC., GEORGE RATERMANN,</b>	)	
<b>PROGRESSIVE PLASTICS, INC. and</b>	)	
<b>HENRY BUERMANN,</b>	)	
	)	
<b>Defendants.</b>	)	

**MEMORANDUM ON CLAIM CONSTRUCTION**

This is a patent infringement action in which Plaintiff Protective Industries Inc, d.b.a. Caplugs, (“Plaintiff ” or “Caplugs”) claims that Defendants Ratermann Manufacturing, Inc. (“RMI”), George Ratermann (“Ratermann”), Progressive Plastics, Inc. (“Progressive”) and Henry Buermann (“Buermann”) (collectively “Defendants”) have infringed and continue to infringe on United States Patent No. 7,681,587 (“the ‘587 patent”). Plaintiff insists that the terms in the patent are clear, but Defendants have requested that the Court construe numerous terms.

On January 13, 2012, and after the parties filed extensive briefing in relation to their respective positions (Docket Nos. 66, 68, 86, 87 & 95), the Court held a hearing on claim construction in accordance with Markman v. Westview Instruments, Inc., 517 U.S. 370 (1996). After the Markman hearing, and with leave of the Court, the parties filed supplemental briefs on claim construction. (Docket Nos. 100, 102, 109 & 111).

## **I. FACTUAL BACKGROUND**

The device covered by the '587 patent was invented by Frederick Zeyfang ("Zeyfang"). The patent is titled GAS BOTTLE VALVE STEM PROTECTIVE SLEEVE, and, as the name implies, claims a sleeve for use as a protective device on the valve stem of a compressed gas cylinder.

According to the patent, the protective sleeve serves a number of salutary purposes. These include: (1) protecting the valve stem from environmental contamination during shipping or storage; (2) serving as a tamper-proof use indicator for prospective users of the compressed gas cylinder; and (3) indicating whether the tank is full or empty. ('587 patent, Col. 1ln.15-30).

The protective sleeve at issue is particularly suited to fit over the CGA-870 valve which is the standard valve developed by the Compressed Gas Association for use on compressed oxygen gas cylinders. The CGA-870 valve has three holes<sup>1</sup> on one face: an upper hole which is the gas outlet, and two lower holes which are referred to as "pin index" holes. A regulator that fits into both the gas outlet hole and the pin index holes in the valve allows the user to access the gas.

Pin index holes are part of the "Pin Index Safety System," which is a system designed to ensure that the correct gas is filled into the correct cylinder, thereby preventing gases from being confused with one another. Thus, pin index holes are arranged such that only a regulator designed for oxygen can be connected to an oxygen bottle valve, a regulator designed for nitrogen can only be connected to a nitrogen bottle valve, and so forth.

The following diagram illustrates the location of the gas outlet hole, and the different locations of the pin index holes for oxygen and nitrous oxide, respectively:

---

<sup>1</sup> In using the word "holes," the Court recognizes that there is a dispute between the parties as to whether the face has several "holes" as opposed to some "holes" and "orifices." This dispute is discussed in the context of claim construction below.

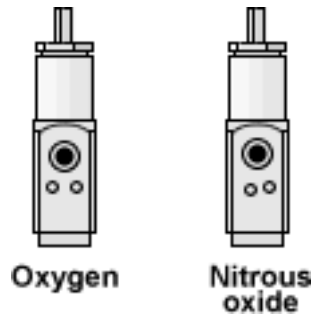

Given the slightly different location of the pin index holes, a user of oxygen cannot accidentally attach his or her regulator to a cylinder containing nitrous oxide or some other sort of gas because the pin index holes will not line up with the prongs on the regulator.

The opposite side of a CGA-870 valve contains a hole that is commonly referred to as the “burst disc.” If the pressure in the bottle gets too high, the disc bursts, allowing the gas to escape and preventing explosion of the bottle.

Because oxygen bottles are shipped and stored after filling, it is desirable that the valve, and particularly the orifice through which the oxygen passes, be protected. It is also desirable that any such protective device be easy to install and easy to remove because oxygen cylinders are filled in large quantities in gas filling plants, and the end users are often elderly or infirm.

Plaintiff’s protective sleeve is a four-sided plastic sleeve which slides over the top of the valve stem and is configured to fit fairly snugly around the valve. Inside of the sleeve is a prong which snaps into the gas outlet hole when placed over the valve,<sup>2</sup> thereby securing the sleeve to the valve. The end user removes the sleeve by pulling on a tab which tears a piece of the plastic from

---

<sup>2</sup> This is what is shown in the figures illustrating the protective sleeve in the ‘587 patent . However, Claim 1 speaks of “*an* outwardly extending projection . . . adapted to physically engage with *an* orifice,” while Claim 6 speaks of a protective sleeve containing “*multiple* outwardly extending projections . . . for engagement in *multiple* orifices in said valve stem.” (‘587 Patent, Col.4 ln. 7-9 & 41-43) (italics added).

one side.

Figure 1 of the patent shows a typical embodiment of the device “installed in protective position over a gas valve of a gas bottle”:

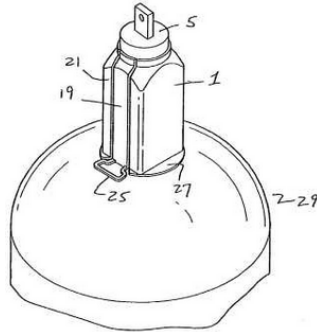

(‘587 Patent, Fig. 1 & Col. 1, ln. 63-65). In the illustration, the device (1) is shown surrounding the valve stem (5) of the cylinder (29). The tear strip (19) extends longitudinally along one side of the sleeve (21). (*Id.* Col. 3 ln. 4-7). Attached to the tear strip is a grip member (25) which “facilitate[s] tearing of the tear strip.” (*Id.* Col. 3 ln. 26-27). At the bottom of the protective sleeve is a flange (27).

Plaintiff asserts that its protective sleeve has been enormously popular for many fillers of medical oxygen gas cylinders. In fact, Plaintiff claims that, since its commercial introduction in early 2007, sales of Plaintiff’s sleeves “have risen from approximately 6,000,000 in its first year to nearly 18,000,000 at present.” (Docket No. 66 at 3).

Plaintiff’s protective sleeve is hardly the first invention directed towards protecting valves on gas cylinders during transportation and storage. Devices have included not only pull-over sleeves (like Plaintiff’s), but also cellulose wet bands, wrap around sleeves,<sup>3</sup> plugs, and shrink wrap.

---

<sup>3</sup> A wrap-around sleeve of relevance here is the one invented by Derek I. Darley and granted United States Patent Number 5,191,992 (the “Darley patent”). That patent is discussed in the context of claim construction below.

According to Defendants, one of the earliest protective sleeve devices was invented in 1960 by Lynn Davis. It was granted United States Patent Number 3,125,242 (the “Davis ’242 patent) which expired long ago.

The Davis protective sleeve is four-sided, slides over the valve, and locks into place by way of a projection that fits into the gas outlet hole. This device includes a tear strip and grip member at the top of the tear strip for removal. To accommodate valves requiring washers to create an effective seal, this device also has an indentation for the washer to fit inside.<sup>4</sup>

For many years, Defendant Progressive manufactured the Davis sleeve which was then sold to end users and distributors such as Defendant RMI. Over time, Progressive refined that sleeve.

In 2006, Defendant Buermann (who is also the Chief Executive Officer of Progressive) added flanges to the side of the sleeve. This was patented under Design Patent Number D612,012.<sup>5</sup>

In late 2007, Buermann filed a patent application for further refinements to the Davis sleeve. The new device incorporated many of the features of the Davis sleeve (such as the tear strip with grip member), but is taller and includes flanges. This sleeve has an external washer holder built into the tear strip, and engages in the pin index holes, instead of the gas outlet hole. An overhead view of the device, is illustrated below:

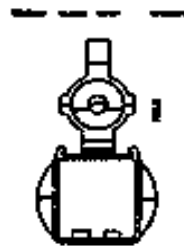

---

<sup>4</sup> Another older protective sleeve is the Moss Plastics sleeve. It, too, is a four-sided pull over sleeve that includes an interior projection which fits into the gas outlet hole, and a tear strip with a grip member for ease of removal. Unlike the grip member on the Davis protective sleeve, the grip member on this sleeve is perpendicular to the tear strip.

<sup>5</sup> Generally, a “design patent” protects the way an article looks, 35 U.S.C. § 171, while a “utility patent” protects the way the article is used, 35 U.S.C. § 101. A design patent is designated by a “D” placed in front of the patent number.

From this perspective, the top is the tear strip (with an indentation for housing a washer) which in the above configuration is pulled down and attached to one of the four walls of the device. On the left and right hand walls are the flanges. On the bottom wall are two indentations for securing the sleeve to the valve by utilizing the pin index holes. This device was granted Patent No. D612,013, and was sold by RMI beginning in November, 2007.<sup>6</sup>

Plaintiff filed its application for patent on September 15, 2006, and began selling its protective sleeve in February 2007. Shortly thereafter, according to Plaintiff, “RMI introduced a competing product which copied the patented features Caplug’s product,” and which “were specifically designed and manufactured by Progressive and Buermann for sale by RMI in the United States in direct competition with Caplugs to meet the competitive advantage of Caplug’s protective sleeve.” (Docket No. 1, Complaint ¶¶ 29 & 31). The allegedly infringing competing product was the protective sleeve which matured into Patent D612,013, but the application for that patent was not filed until October 2, 2007, some eight months after Plaintiff began marketing its protective sleeve. (Id. ¶ 36).

On May 19, 2010, Plaintiff wrote Defendants informing them that the ‘587 Patent had been issued, and suggesting that their protective sleeve infringed. Defendants responded by indicating

---

<sup>6</sup> Apart from adding refinements to the Davis device, Buermann invented a wrap-around sleeve which wraps around a valve and locks into place. It has a tear strip with grip member, an indentation for holding a washer, and a projection that fits into the gas outlet hole to secure the device to the valve.

that a request for reexamination of the '587 Patent had been filed, and that they would not take any action until the reexamination proceedings had been concluded.

In response to an *inter partes* reexamination request<sup>7</sup> from Progressive, the United States Patent and Trade Office (“USPTO”) on September 14, 2010, found “[a] substantial new question of patentability affecting claims 1-7” of the '587 patent, and issued an Office Action in which the Examiner proposed rejecting Claim 1-4 and 7 as being unpatentable over the Davis '242 patent “in view of” an existing British patent, and a patent for a pressure release safety cap invented by Buermann. (Docket Nos. 13-2 at 5 & 13-3 at 20). The office action is ongoing, and a Motion to Stay these proceedings pending conclusion of the *inter partes* reexamination was denied by Judge Trauger. (Docket No. 27).

On November 2, 2010, Caplugs filed suit in this Court asserting patent infringement against each of the Defendants. In response, Defendants filed Answers and Counterclaims, denying infringement, and claiming that '587 patent was invalid and unenforceable because Plaintiff intentionally failed to disclose to the Examiner prior art and other information material to the patentability of the invention.

## **II. GENERAL PRINCIPLES RELATING TO CLAIM CONSTRUCTION**

Claims construction is a two-step process. In the first step, which the Court undertakes now, the Court determines, as a matter of law, the scope of the patent claim. See Markman, 517 U.S. at 384, 388; Altiris, Inc. v. Symantec Corp., 318 F.3d 1363, 1368 (Fed. Cir. 2003); Teleflex, Inc. v.

---

<sup>7</sup> Both *ex parte* and *inter partes* reexamination requests are initiated by requests from the public. They differ, however, in that, in *ex parte* requests (which may be submitted anonymously), once the request is made, the requester is no longer involved in the process whereas, in *inter parte* requests, the requesting party participates throughout the reexamination process, and may comment on responses given to the Examiner by the patent holder. See, 35 U.S.C. §§ 311-314.

Ficosa North Am. Corp., 299 F.3d 1313, 1323 (Fed. Cir. 2002). Once that scope is determined, the allegedly infringing device is compared to the patent claims, and, if necessary, a jury (or a court in a bench trial) determines, as a matter of fact, whether all of the limitations of at least one claim are present, either literally or by a substantial equivalent, in the accused device. Teleflex, Inc., 299 F.3d at 1323; Southwall Tech., Inc. v. Cardinal IG Co., 54 F.3d 1570, 1575 (Fed. Cir. 1995).

“[A] patent must describe the exact scope of an invention and its manufacture to ‘secure to [the patentee] all to which he is entitled, [and] to apprise the public of what is still open to them.’” Markman, 517 U.S. at 373 (citation omitted). This is accomplished in the claim(s) and the specification(s) which are set forth in the patent document and which, by statute, are required to be as follows:

The specification shall contain a written description of the invention, and of the manner and process of making and using it, in such full, clear, concise, and exact terms as to enable any person skilled in the art to which it pertains, or with which it is most nearly connected, to make and use the same, and shall set forth the best mode contemplated by the inventor of carrying out his invention.

The specification shall conclude with one or more claims particularly pointing out and distinctly claiming the subject matter which the applicant regards as his invention.

A claim may be written in independent or, if the nature of the case admits, in dependent or multiple dependent form.

35 U.S.C. § 112.

“It is well-settled that, in interpreting an asserted claim, the court should look first to the intrinsic evidence of record, *i.e.*, the patent itself, including the claims, the specification and, if in evidence, the prosecution history.” Vitronics Corp. v. Conceptronic, Inc., 90 F.3d 1576, 1582 (Fed. Cir. 1996). “Such intrinsic evidence is the most significant source of the legally operative meaning of disputed claim language,” and, therefore, resort to extrinsic evidence such as expert opinions and



dictionaries is improper unless the analysis of the intrinsic evidence does not resolve any ambiguities in the claim terms. Id. at 1583.

“All intrinsic evidence is not equal however.” Interactive Gift Exp., Inc. v. Compuserve Inc., 256 F.3d 1323, 1331 (Fed. Cir. 2001). Rather, a court looks first to the claim language. Id. “If the claim language is clear on its face, then . . . consideration of the rest of the intrinsic evidence is restricted to determining if a deviation from the clear language of the claims is specified.” Id. “If however the claim language is not clear on its face, then . . . consideration of the rest of the intrinsic evidence is directed to resolving, if possible, the lack of clarity.” Id.

In construing a disputed claim term, the term is given its “ordinary and customary meaning,” which “is the meaning that the term would have to a person of ordinary skill in the art in question at the time of the invention.” Phillips v. AWH Corp., 415 F.3d 1303, 1313 (Fed. Cir. 2005). This “provides an objective baseline from which to begin claim interpretation,” because “patents are addressed to and intended to be read by others of skill in the pertinent art.” Id.

“Importantly, the person of ordinary skill in the art is deemed to read the claim term not only in the context of the particular claim in which the disputed term appears, but in the context of the entire patent, including the specification.” Id. The specification can be highly relevant to the claim construction analysis because, by way of examples, the inventor may define his own terms in the specification, or “[t]he patentee may demonstrate an intent to deviate from the ordinary and accustomed meaning of a claim term by including in the specification expressions of manifest exclusion or restriction, representing a clear disavowal of claim scope.” Teleflex, 299 F.3d at 1325; see, Interactive Gift, 256 F.3d at 1331 (citation omitted) (“A deviation may be necessary if ‘a patentee [has chosen] to be his own lexicographer and use terms in a manner other than their

ordinary meaning,” or “if a patentee has ‘relinquished [a] potential claim construction in an amendment to the claim or in an argument to overcome or distinguish a reference.’”). “Likewise, the prosecution history may demonstrate that the patentee intended to deviate from a term's ordinary and accustomed meaning[.]” Id.

“If the meaning of the claim limitations is apparent from the totality of the intrinsic evidence, then the claim has been construed.” Interactive Gift, 256 F.3d at 1332. “If however a claim limitation is still not clear, [a court] may look to extrinsic evidence to help resolve the lack of clarity,” id., and to assist the court in “comprehending the technology in accordance with the understanding of skilled artisans[.]” Altiris, Inc., 318 F.3d at 1369. “Extrinsic evidence may never be relied upon, however, to vary or contradict the clear meaning of terms in the claims.” Id. “Any other rule would be unfair to competitors who must be able to rely on the patent documents themselves, without consideration of expert opinion that then does not even exist, in ascertaining the scope of a patentee’s right to exclude.” Southwall Technologies, Inc., 54 F.3d at 1578.

With these legal principles in mind, the Court turns to the claim construction in this case.

### **III. CLAIM CONSTRUCTION FOR THE '587 PATENT**

The Court is called upon to construe the following terms and/or phrases found in the '587 patent: (1) “elongated”; (2) “a portion of the length”; (3) “said sides of said unitary body configured to conform to adjacent faces of said valve stems”; (4) “in protective relationship thereto”; (5) “along a plane transverse to said longitudinal axis”; (6) “orifice”; and (7) “flange”. As indicated, Plaintiff asserts that each of the words and terms in the patent are clear, and a jury can understand the plain and ordinary meaning of those words and terms.

#### **A. Terms Related to Size and Shape**

Many of the terms sought to be construed are found in Claim 1 and relate to the size and/or shape of the protective sleeve. Because the Federal Circuit has “reinforced the importance of construing claim terms in light of the surrounding claim language,” Digital-Vending Serv. Intern., LLC v. Univ. of Phoenix, Inc., 672 F.3d 1270, \_\_\_, (Fed. Cir. 2012), the Court considers the terms relating to the size and shape of the protective sleeve in the context of the language in which it appears. With the disputed terms at issue in bold face, the beginning of Claim 1 reads as follows:

1. A protective sleeve for use in connection with valve stems for gas bottles, said protective sleeve comprised of an **elongated** four-sided unitary molded tubular body having opposing open ends, said body being of such length as to extend along at least **a portion of the length** of said valve stem, **said sides of said unitary body configured to conform to adjacent faces of said valve stem in protective relationship thereto** when said protective sleeve is placed over said valve stem [.]

(‘587 Patent Col 3 ln. 48 to Col. 4 ln. 17).

#### **1. *Elongated***

Plaintiff claims that if construction of the term elongated is necessary, the term should be read as meaning “lengthened” or “having some length.” In response, Defendants assert that Plaintiff is trying to read the term “elongated” out of Claim 1 because, over time, Caplugs learned that “customers did not want an elongated sleeve,” and, “[c]onsequently, Caplugs’ protective sleeve began to shrink smaller and smaller,” such that it is now narrower than it is wide. (Docket No. 95 at 7). Defendants propose that the term elongated be construed to mean “having a form significantly long in relation to its width.”

Obviously, the word “elongated” cannot be read out of Claim 1 because the court is to ““give meaning to all the words in [the] claims.”” Funai Elec. Co. v. Daewoo Elec. Corp., 616 F.3d 1357, 1372 (Fed. Cir. 2010) (citation omitted, bracket in original). That said, the Court finds that the term “elongated” is clear and that, if any definition is needed, the term is to be defined as “longer than

it is wide.”

In doing so, the Court rejects the proposed definitions proffered by Plaintiff and Defendants. Plaintiff’s proposed construction is unhelpful because it sheds no light on the meaning of the term elongated, and begs the obvious question: “lengthened” or “having some length” in relation to what? The argument that Defendants advance in support of their proposed construction adds another layer to the word (and hence to the claim) because they assert that “[a] lay jury can certainly understand what ‘significantly’ means: If it is apparent to the naked eye that the protective sleeve is longer than it is wide, such that it is unnecessary to consult a ruler to compare its measurement, the sleeve certainly has a form significantly long in relation to its width.” (Docket No. 95 at 8, emphasis in original).

***2. A Portion of the Length – Said Sides of Said Unitary Body Configured to Conform to Adjacent Faces of Said Valve Stem – In Protective Relationship Thereto***

Stripped to its essence, the parties dispute about these terms relate to whether the protective sleeve must cover up the valve faces. Thus, while they agree that “protective relationship thereto” means to cover the adjacent faces of the valve stem, they part company as to what amount of the valve stem the device covers, with Defendants taking the position that the entire valve face must be covered by the protective sleeve.

**a. Portion of the Length**

Plaintiff asserts that a “portion of the length” means a part of the length of the valve stem, and not the “length of the valve faces” (which is a part of the length of the valve stem) as Defendants contend. In the Court’s opinion, a “portion of the length” means exactly what it says, and, standing alone, does not require that it necessarily be “the length of the valve faces,” only that it be a part of the length of the valve.

While it is true that “a portion of the length” of the valve stem would include the entire length of the valve faces, it is also true that a “portion of the length” of the valve stem would also include a “portion of the length” of the valve faces:

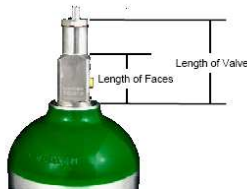

A portion of the length could therefore be most of the valve stem, the entire length of the valve faces, a portion of the length of the valve faces, or a greater length than the valve faces, or somewhere in between.

That said, “a portion of the length” cannot be read in isolation because the remaining disputed terms in Claim 1 give context to what “a portion of the length” means.

**b. Said Sides of Said Unitary Body Configured to Conform to Adjacent Faces of Said Valve Stem**

Caplugs argues that if any construction of this phrase is needed, the proper definition is “the sides of the device, which extend at least a part of the length of the valve stem, are designed to be of similar shape to the parts of the sides of the valve stem which the sides cover.” Defendants, believing that the device must cover the valve faces, propose as a definition, “said sides of said unitary body having a shape substantially the same shape of adjacent faces of said valve stem,” which is illustrated as follows:

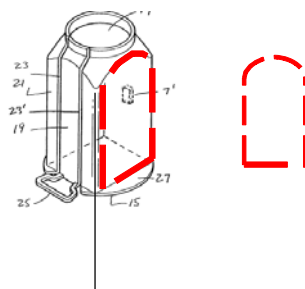

(Docket No. 68 at 14). Under Defendants' construction, therefore, the shape and size of the device mirror the shape and sides of the valve faces, to wit the rectangular-shaped, arch-topped flat portions of the valve.

Having considered the evidence in the record and the arguments of the parties, the Court agrees with Defendants that Claim 1 describes a sleeve which covers and takes the shape of the valve faces. Several factors lead to that conclusion.

First, and most importantly, the claim language itself states that the sides of the protective sleeve are "configured to conform to adjacent faces of said valve stem" and, in so doing, serve in a "protective relationship thereto." The claim language does not state that the sides of the protective sleeve are configured to conform to a portion or a part of the adjacent faces. The fact that this language is prefaced with language which states that the protective sleeve must be of "such length as to extend along at least a portion of the length" of the valve stem does not change this conclusion because a protective sleeve which covers the faces necessarily extends along at least a portion of the valve stem.

Second, and related to the last point, the prosecution history supports this construction. Claim 1 was amended to overcome the PTO Examiner's rejection of the claim in view of the Darley patent which teaches a tamper proof seal that wraps around a valve cylinder. While Plaintiff insists that Darley was distinguishable on the basis that it was a wrap around (as opposed to a slide over) sleeve, the inventor's response to the Examiner's observation went much further than merely making that distinction:

. . . [C]laim 1 is amended to state that the claimed protective sleeve is comprised of an open-ended elongated four-sided unitary body of such length as to extend along at least a portion of the length of said valve stem in protective relationship thereto when said protective sleeve is placed over said valve stem. By contrast, the sealing

arrangement of the reference comprises a body capable of being wrapped around a valve of a gas cylinder, and secured thereto by means of a strap [with] tooth-shaped projections which are inserted into locking holes.

(Docket No. 68-10 at 7, references to numbers in Darley patent omitted). If the Darley patent was readily distinguishable based solely up the fact that it was a wrap-around sleeve, Plaintiff's response could have ended with the addition of language about its device being "an open-ended elongated four-sided unitary body."

Third, all of the drawings in the '587 patent support the construction of a protective device which takes the shape of, and covers, the valve faces. Patent drawings can be "highly relevant in construing" the claims of a patent. CVI/Beta Ventures, Inc. v. Tura LP, 112 F.3d 1146, 1153 (Fed. Cir. 1997). While it is true that "drawings in a patent need not illustrate the full scope of the invention," Arlington Indus., Inc. v. Bridgeport Fittings, Inc., 632 F.3d 1245, (Fed. Cir. 2011), and "patent coverage is not necessarily limited to those inventions that look like the ones in the figures," MBO Lab., Inc. v. Becton, Dickinson & Co., 474 F.3d 1324, 1333 (Fed. Cir. 2007), it is significant that Figures 1 and 2 show the protective sleeve, and Figures 2B, 3, and 4 are said to be different embodiments of the sleeve, yet each and every embodiment depicted shows a sleeve which is designed to cover the valve faces and is made to conform to the shape of the faces on a CGA-870 valve. It is also significant that prior art in the form of the Davis and Moss Plastic sleeves show a device which slides over the valve stem but when put in place does not cover the valve faces.

## **B. Terms Unrelated to Size and Shape**

### ***1. Along a Plane Transverse to Said Longitudinal Access***

This phrase appears twice in Claim 1 and is utilized in connection with the orientation of both the flange and the grip member. Specifically, Claim 1 ends with the following language:

said sleeve further including at least one flange extending laterally outwardly from the bottom of said sleeve along a plane transverse to a longitudinal axis of said unitary molded tubular body, and a grip member which extends laterally outwardly from said sleeve along a plane transverse to said longitudinal axis of said unitary molded tubular body and attached to a portion of said tear strip to facilitate tearing of said tear strip.

(‘587 Patent Col. 4 ln. 20 to 26, emphasis added).

Plaintiff asserts that if any construction of the phrase is necessary, it should be construed as meaning “along a plane that extends across the longitudinal access,” while Defendants propose the construction, “at a right angle to the long axis.” The essence of the dispute here is whether the flange and group member must be on a plane that merely crosses the longitudinal access as Plaintiff contends, or one that is at a right angle to the longitudinal access as Defendants maintain.

In the original patent application, Claim 1 did not contain a flange or a grip member. The claim was then amended to include language about a “flange extending laterally outwardly” and a “grip member which extends laterally outwardly.” After the Examiner noted that Darley teaches “at least one flange . . . extending laterally outwardly from the bottom of the sleeve . . . and a grip member which extends laterally outwardly from the sleeve,” (Docket No. 68-12 at 3), Claim 1 was again amended to add the “along a plane transverse to a [or said] longitudinal axis” language.

Contrary to Defendants’ position, the Court does not consider this prosecution history to show that the flange and grip member must be at “a right angle to the long axis,” as opposed to being “along a plane that extends across the longitudinal axis.” This is best seen by comparing figures from the Darley prior art:

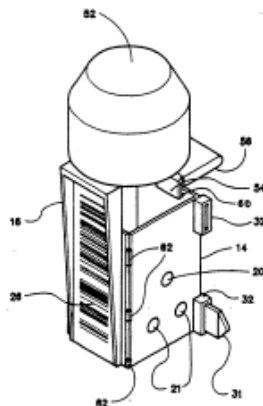

member must be at “a right angle to the long axis,” as opposed to being “along a plane that extends across the longitudinal axis.” This is best seen by comparing figures from the Darley prior art:



to a portion of a figure from the '587 patent:

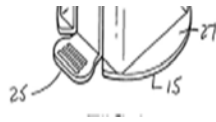

In the Darley patent, the flange (15) extends *along* and in the same direction of the longitudinal axis, while in the '587 patent the flange (27) runs *across* the longitudinal axis. Darley does not disclose flanges that cross the longitudinal axis – it discloses flanges extending from the sleeve in the same direction as the longitudinal access.

In determining that the phrase “along a plane transverse to a longitudinal axis” should be construed as “along a plane that extends across the longitudinal axis,” the Court recognizes that “transverse” can be defined as “made at right angles to the long axis of the body.” In fact, Defendants cite Webster’s for that proposition, but that same dictionary’s first definition for transverse is “acting, lying or *being across*; set *crosswise*.” (Docket No. 68-12 at 16); see also, MACMILLAN DICTIONARY ONLINE, [www.Macmillandictionary.com](http://www.Macmillandictionary.com) (last visited May 2, 2012) (defining “transverse” as “placed sideways or at an angle across something”).

## **2. Orifice**

This word appears at several points in Claim 1 in conjunction with the projection on the sleeve which is designed to lock into the “orifice.” Caplugs asserts that “orifice” need not be defined but that, if a definition is required, it should be a “hole.” Defendants argue the term

“orifice” should be construed to mean “an opening in a valve face for intake or exhaust of gas.” The Court rejects Defendants’ position, and finds that “orifice” needs no further definition, but if one is necessary, an “orifice” is a “hole.”

In support of their position, Defendants argue that an “orifice” means a hole through which something may pass, meaning that it would be limited to the gas outlet hole and the burst disc on the CGA-870 valve. Defendants insist this understanding is confirmed by the specifications which teach that to ensure purity, “it is important that a dust cover (or protective cover) be employed to cover the valve orifice in order to prevent the entry of dirt and/or debris therein,” and that an “object of the present invention [is] to provide a protective sleeve that will serve to seal an orifice in the post stem of a gas bottle.” (‘587 Patent Col. 1 ln. 15 to 18 & 38-40).

Although the referenced specifications can be read to lend some support to Defendants’ argument, “the entry of dirt and debris into the valve” can be thwarted by a tight fitting “protective sleeve” that covers the face of the valve. Moreover, the patent speaks not only in terms of “an orifice,” but also “multiple outwardly extending projections . . . for engagement in multiple orifices in said valve stem.” (‘587 Patent, Col.4 ln. 7-9 & 41-43). Under Defendants’ construction, this embodiment would be limited to engagement of the projection in either the gas outlet hole and/or the burst disc hole, the latter of which may be of questionable efficacy. Further, in discussing the ‘587 patent in relation to the Darley patent, the Examiner noted that Darley discloses a sleeve with “multiple outwardly extending projections . . . for engagement in multiple orifices” and identifies as orifices, not only the gas outlet hole, but also the pin index holes. (Docket No. 66-10 at 135).

### **3. Flange**

As noted, Claim 1 of the ‘587 patent did not reference a “flange.” Where “flange” did

appear, it was referenced in the context of a “support flange.” Given how the patent developed over time, Defendants argue that “flange” must be construed as “support flange,” and, moreover, the flange “must extend to the top of the gas bottle, thereby providing support for the protective sleeve.” (Docket No. 68 at 24). The Court disagrees with Defendants’ position, and construes “flange” as a “rim or an edge”.

“Flange” and “support flange” are two different terms, and Federal Circuit “precedent instructs that different claim terms are presumed to have different meanings.” Helsderfer v. Bobrick Washroom Equip., Inc., 527 F.3d 1379, 1382 (Fed. Cir. 2008). The Federal Circuit also employs the doctrine of claim differentiation whereby, as a general rule, “the presence of a dependent claim that adds a particular limitation gives rise to a presumption that the limitation in question is not present in the independent claim,” Phillips, 415 F.3d at 1315, a presumption that “is especially strong when the limitation in dispute is the only meaningful difference between an independent and dependent claim[.]” SunRace Roots Enter. Co. v. SRAM Corp., 336 F.3d 1298, 1303 (Fed. Cir. 2003).

The '587 patent as issued references in Claim 1 a protective sleeve that “includ[es] as least one flange extending laterally outwardly from the bottom of said sleeve,” and, in Claim 5, a protective sleeve “including multiple support flange members extending laterally outwardly from the bottom of said protective sleeve.” ('587 Patent, Col.4 ln. 20-22 & 37-39). By providing for “at least one flange,” Claim 1 encompasses a protective sleeve with multiple flanges, and, therefore, Claim 5 is differentiated from Claim 1 because it speaks of “support flanges.”

Even if, as Defendants contend, Claim 1 can be differentiated from Claim 5 not on the basis of the “flange” / “support flange” distinction, but rather because Claim 5 contemplates multiple

flanges, the prosecution history supports the conclusion that the “flange” in Claim 1 does not necessarily have to be a “support flange.” In this regard, Plaintiff points to the following language in which the inventor distinguishes Buermann: “[B]y contrast, applicant’s flange members are intended to facilitate installation of the protective cap upon the gas cylinder[.]” (Docket No. 68-10 at 7).

Defendants concede the inventor’s language is “instructive,” but reads it to mean that, when “properly installed, the protective cap is upon the gas cylinder body.” (Docket No. 95 at 5, emphasis in original). In the Court’s opinion, a fairer reading of this language is that the flange is intended to aid in sliding the sleeve over the valve when placing it on the gas cylinder valve.

Defendants also point to the figures in the ‘587 patent which appear to show the flanges resting on the top of the gas cylinder. However, and contrary to Defendants position, it does not necessarily follow that the flanges are “supporting the sleeve upon the bottle.” (Docket No. 63 at 23). It could equally be the case that the tension in the sleeve and the interlocking device are what is supporting the sleeve. In any event, and as previously noted, “patent coverage is not necessarily limited to those inventions that look like the ones in the figures.” MBO Lab., 474 F.3d at 1333.

#### **IV. CONCLUSION**

Based upon the foregoing, the Court construes the disputed terms and phrases for the ‘587 patent as follows:

<b>TERMS AND PHRASES</b>	<b>COURT’S CONSTRUCTION</b>
“elongated”	no construction necessary but, if construed, “longer than it is wide”

“portion of the length”	no construction necessary but, if construed, “part of the length”
“said sides of said unitary body configured to conform to adjacent phrases of said valve stem”	“said sides of said unitary body having a shape substantially the same shape of adjacent faces of said valve stem”
“protective relationship thereto”	“to cover”
“along a plane transverse to said longitudinal axis”	“along a plane that extends across the longitudinal axis”
“orifice”	no construction necessary but, if construed, “a hole”
“flange”	“a rim or an edge”

The Court will enter an Order confirming the foregoing claim construction.

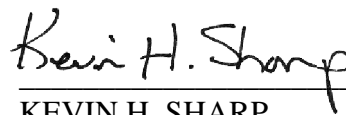

---

KEVIN H. SHARP  
UNITED STATES DISTRICT JUDGE