

IN THE UNITED STATES DISTRICT COURT
FOR THE WESTERN DISTRICT OF TENNESSEE
EASTERN DIVISION

UNDERCOVER, INC. and LAURMARK
ENTERPRISES, INC. D/B/A BAK
INDUSTRIES,
Plaintiffs/Counterclaim-Defendants,
v.
ROUGH COUNTRY, LCC,
Defendant/Counterclaim-Plaintiff.
v.
REALTRUCK, INC. and REALTRUCK
ENTERPRISE, INC.,
Counterclaim-Defendants.
Case No. 1:24-cv-1093-JPM-jay

ORDER GRANTING MOTION TO DISMISS COUNT VII OF AMENDED
COUNTERCLAIM

Before the Court is a Motion to Dismiss Count VII of Amended Counterclaims, filed on
July 17, 2024, brought by Counterclaim Defendants UnderCover, Inc. ("UnderCover"), Laurmark
Enterprises, Inc. d/b/a BAK Industries ("BAK"), RealTruck, Inc. ("RealTruck"), and RealTruck
Enterprise, Inc. ("RealTruck Enterprise") (collectively, "Counterclaim Defendants"). Because
Defendant/Counterclaim Plaintiff Rough Country ("Defendant," "Counterclaim Plaintiff," or
"Rough Country") has failed to plead sufficient facts to state a claim upon which relief could be
granted, the Motion to Dismiss Count VII of Amended Counterclaims is GRANTED.

I. BACKGROUND¹

A. Complaint and Patents

This dispute relates to the claimed inventions of U.S. Patent Nos. 9,815,358 (“’358 Patent”), 8,690,224 (“’224 Patent”), and 7,537,264 (“’264 Patent”) (collectively, “the Asserted Patents”) which generally relate to “tonneau covers” or “tonneaus,” which are truck bed covers used to protect pickup truck beds against the environment. (ECF No. 1 at PageID 1–2.) The Complaint asserts that Defendant infringes at least one claim of one or more of the Asserted Patents through some of its products (“Accused Products”), including but not limited to the Rough Country Hard Tri-Fold Flip Up Bed Cover series. (Id. at PageID 6-7.)

The ’358 Patent relates to foldable tonneau covers for shielding a cargo box of a pickup truck, and specifically the forward section of such foldable tonneau covers. (U.S. Patent No. 9,815,358 col. 1 l. 6–9 (issued Nov. 14, 2017).)

The ’224 Patent and ’264 Patents relate to a cover assembly for pickup truck cargo boxes with attachable rails to the sides of the cargo box, where a multi-panel covering is supported on the rails, and the panels are connected by hinge strips. (U.S. Patent No. 8,690,224 col. 1 l. 52–60 (issued Apr. 8, 2014); U.S. Patent No. 7,537,264 col. 1 l. 44–52 (issued May 26, 2009).)

An example graphic demonstrating the technology from all three patents is below:

¹ For purposes of the Motion to Dismiss, the Court takes the facts alleged in Defendant’s Answer, Affirmative Defenses, and Amended Counterclaims as true. This section should not be construed as a finding on any listed fact.

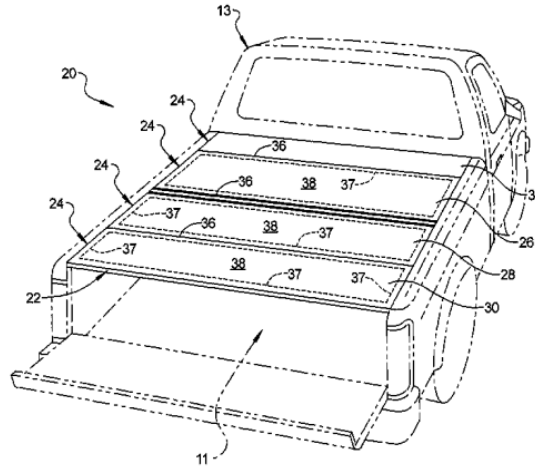

(ECF No. 1-3 at PageID 20.)

B. Relationship Between the Parties

UnderCover and BAK (collectively, “Plaintiffs”) both manufacture tonneau covers. (ECF No. 1 at PageID 4.) RealTruck acquired UnderCover and BAK in 2010 and 2014, respectively.

(Id.)

Plaintiffs have a previous history with Defendant. (Id. at PageID 5.) Defendant and Counterclaim Defendants are competitors in the “aftermarket hard-folding truck-bed cover market.” (ECF No. 31 at PageID 213.)

Previously, Defendant had purchased hard folding truck bed covers from Rugged Liner, a third party to this action, pursuant to an agreement. (ECF No. 31 at PageID 220.) In 2016, during this agreement, Rugged Liner was purchased by RealTruck’s predecessor in interest. (Id.; ECF No. 1 at PageID 5.) Plaintiffs and Defendant continued to work together, with Plaintiffs and their parent company RealTruck providing truck bed covers to Defendant until sometime in 2023. (ECF No. 31 at PageID 220–21.) In April 2024, Plaintiffs initiated this lawsuit. (ECF No. 1.)

Because there are multiple parties with different labels involved, a simplified diagram is below:

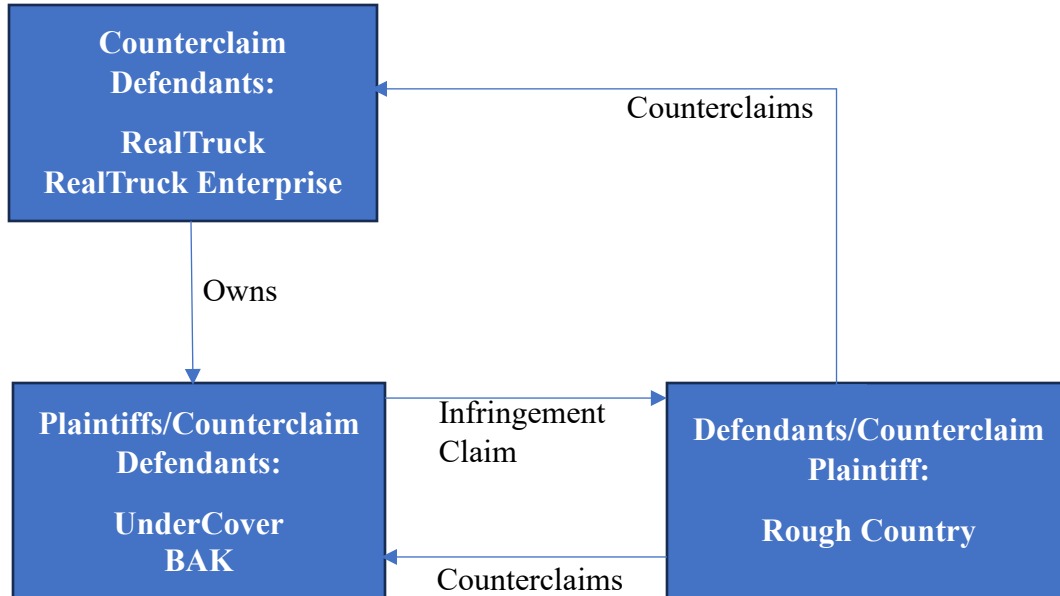

C. Previous Litigations

i. *The BAK Litigation*

Around 2012, RealTruck’s predecessor in interest sought to acquire BAK. (*Id.*) When negotiations broke down, UnderCover and a sister entity filed a declaratory judgment against BAK, seeking non-infringement and invalidity of the ’264 Patent. (*Id.*) BAK then filed a patent infringement lawsuit against UnderCover and RealTruck, among others, alleging infringement of claims 16 and 18 of the ’264 Patent. (*Id.* at PageID 213–214.) UnderCover, in response, served contentions asserting invalidity of all claims of the ’264 Patent, and non-infringement of claims 16 and 18. (*Id.* at PageID 214.) In 2014, UnderCover and RealTruck settled the litigation with BAK, with RealTruck’s predecessor in interest acquiring BAK in the process. (*Id.*)

ii. *The Leer Litigation*

In 2016, RealTruck’s predecessor entity acquired Rugged Liner. (ECF No. 31 at PageID 216.) Before this acquisition, Rugged Liner worked with Truck Accessories Group, LLC d/b/a

Leer, Inc. (“Leer”) to develop Leer’s X2T tonneau cover product, another folding tonneau cover with an extruded forward section panel. (Id.) The X2T tonneau was commercially marketed during a 2015 trade show, which representatives from Plaintiffs attended. (Id. at PageID 216–17.)

In May 2019, Plaintiffs and Extang (another company owned by RealTruck Entities) sued Leer for patent infringement, alleging infringement of claim one of the ’358 Patent and claims one and twenty-five of the ’264 Patent. (Id. at PageID 217; see also ECF No. 1, 1:19-cv-00923-KAJ (D. Del.)) In response, Leer asserted that the claims at issue were invalid over prior art,² and argued that the X2T tonneau cover was prior art and invalidated at least claim one of the ’358 Patent. (Id. at PageID 217–18.) In the course of the litigation, the Delaware District Court denied multiple motions for summary judgment, including:

- The plaintiffs’ partial motion for summary judgment of infringement of the ’264 Patent. (ECF No. 240 at PageID 12414, 1:19-cv-00923-KAJ (D. Del.))
- The plaintiffs’ partial motion for summary judgment that the X2T tonneau is not prior art. (Id.)
- The defendant’s motion for summary judgment that (1) it does not literally infringe the ’264 and ’358 Patents; (2) it does not willfully infringe the patents; and (3) the asserted claims of the ’264 and ’358 Patents are invalid. (Id. at PageID 12415.)

The parties later settled the case, and in August 2022, the parties filed their Joint Stipulation of Dismissal. (ECF No. 31 at PageID 218; see also ECF No. 280, 1:19-cv-00923-KAJ (D. Del.))

D. The Current Litigation and Procedural Posture

Defendant/Counterclaim Plaintiff’s Answer, Affirmative Defenses, and Amended Counterclaims, dated June 21, 2024, assert noninfringement and invalidity as to all Asserted Patents. (ECF No. 31 at PageID 223-6.) Defendant/Counterclaim Plaintiff alleged this suit is part of a larger effort to obtain and maintain Counterclaim Defendant’s monopoly power on the market

² Defendant/Counterclaim Plaintiff incorporates by reference the invalidity contentions. (See ECF No. 31 at PageID 217; ECF No. 208-4 at PageID 11415–20, 1:19-cv-00923-KAJ (D. Del.))

and aftermarket for hard-folding truck-bed covers. (Id. at PageID 227–28.) In its Answer, Defendant/Counterclaim Plaintiff raised Counterclaim VII, a counterclaim for sham litigation under the Sherman Antitrust Act § 2. (Id. at PageID 227.) In that counterclaim, Defendant/Counterclaim Plaintiff asserted that Counterclaim Defendants have brought a baseless infringement action by asserting patent claims that they know are invalid. (Id. at PageID 229–30.) Specifically, Defendant/Counterclaim Plaintiff alleges that Counterclaim Defendants are “aware that claim 1 of the ’358 [P]atent and claims 16 and 18 of the ’264 [P]atent are invalid.” (Id. at PageID 219.) Defendant/Counterclaim Plaintiff contends that “Plaintiffs’ infringement claims relating to at least claim 1 of the ’358 patent and claims 16 and 18 of the ’264 patent are objectively baseless. No reasonable litigant could expect success on the merits of those claims.” (Id. at PageID 222.)

For the ’358 Patent, Defendant/Counterclaim Plaintiff bases its contention on Leer’s invalidity case involving the X2T tonneau cover product. Defendant/Counterclaim Plaintiff states that “[Plaintiffs] knew at least claim 1 of the ’358 patent was invalid at least upon receiving Leer’s invalidity contentions.” (Id. at PageID 218.)

For the ’264 Patent, Defendant/Counterclaim Plaintiff bases its contention on both Leer’s invalidity case (the X2T tonneau cover product) and BAK’s invalidity case. Specifically, that “Plaintiffs and the owner of both Plaintiffs ha[d] previously asserted in court filings that [claims 16 and 18 of the ’264 Patent] were invalid.” (Id. at PageID 229.) Defendant/Counterclaim Plaintiff argue that “Plaintiffs, RealTruck, and RealTruck Enterprise . . . knew that at least claims 16 and 18 of the ’264 patent were invalid in light of their 2012 to 2014 litigation [with BAK,]” as well as “in light of Leer’s invalidity case.” (Id. at PageID 229, 230.)

Counterclaim Defendants filed the instant motion on July 17, 2024. (ECF No. 42.) Defendant/Counterclaim Plaintiff filed its Response in opposition on August 21, 2024. (ECF No. 53.) Counterclaim Defendants filed their Reply on September 11, 2024.³ (ECF No. 56.)

II. LEGAL STANDARDS

A. Motion to Dismiss for Failure to State a Claim

Federal Rule of Civil Procedure 12(b)(6) allows dismissal of a complaint that “fail[s] to state a claim upon which relief can be granted.” It permits the “defendant to test whether, as a matter of law, the plaintiff is entitled to legal relief even if everything alleged in the complaint is true.” Mayer v. Mylod, 988 F.2d 635, 638 (6th Cir. 1993) (citing Nishiyama v. Dickson Cnty., 814 F.2d 277, 279 (6th Cir. 1987)). A motion to dismiss allows the court to dismiss meritless cases which would waste judicial resources and result in unnecessary discovery. Brown v. City of Memphis, 440 F. Supp. 2d 868, 872 (W.D. Tenn. 2006).

When evaluating a 12(b)(6) motion, the Court must determine whether the complaint alleges “sufficient factual matter, accepted as true, to ‘state a claim to relief that is plausible on its face.’” Ashcroft v. Iqbal, 556 U.S. 662, 678 (2009) (citing Bell Atl. Corp. v. Twombly, 550 U.S. 544, 570 (2007)). This standard is the same for a counterclaim. Scheurer Hosp. v. Lancaster Pollard & Co., No. 12-11536, 2013 WL 173268, at *9 (E.D. Mich. Jan. 16, 2013). A claim is plausible on its face if “the plaintiff pleads factual content that allows the court to draw the reasonable inference that the defendant is liable for the misconduct alleged.” Iqbal, 556 U.S. at 678 (citing Twombly, 550 U.S. at 556).

³ Counterclaim Plaintiff moved for leave to file a Sur-Reply on September 18, 2024. (ECF No. 57.) Counterclaim Defendants oppose this. (ECF No. 58.) Because the Court is granting the Motion to Dismiss, Counterclaim Plaintiff’s need for a Sur-Reply is moot.

A complaint need not contain detailed factual allegations. Twombly, 550 U.S. at 570. A plaintiff without facts who is “armed with nothing more than conclusions,” however, cannot “unlock the doors of discovery.” Iqbal, 556 U.S. at 678–79; Green v. Mut. of Omaha Ins. Co., No. 10-2487, 2011 WL 112735, at *3 (W.D. Tenn. Jan. 13, 2011), aff’d, 481 F. App’x 252 (6th Cir. 2012). A court “need not accept as true legal conclusions or unwarranted factual inferences.” Morgan v. Church’s Fried Chicken, 829 F.2d 10, 12 (6th Cir. 1987). “While legal conclusions can provide the framework of a complaint, they must be supported by factual allegations.” Iqbal, 556 U.S. at 679. “[A] formulaic recitation of the elements of a cause of action will not do.” Twombly, 550 U.S. at 555.

If a court decides that the claim is not plausible, the case may be dismissed at the pleading stage. Iqbal, 556 U.S. at 679.

B. The Noerr-Pennington Doctrine and the Sham Litigation Exception

In Eastern Railroad Presidents Conference v. Noerr Motor Freight, Inc., the Supreme Court found that “no violation of the [Sherman Antitrust] Act can be predicated upon mere attempts [by private parties] to influence the passage or enforcement of laws.” See 365 U.S. 127, 135–36 (1961). Since Noerr, the Supreme Court has extended this protection to other forms of governmental action, including administrative action, see United Mine Workers of America v. Pennington, 381 U.S. 657 (1965), and judicial proceedings, see California Motor Transport Company v. Trucking Unlimited, 404 U.S. 508 (1972). Thus, under the Noerr-Pennington doctrine, a party is generally immunized from antitrust liability for bringing a lawsuit. See id. at 510–11.

However, the Supreme Court carved out an exception to this doctrine: sham litigation. See Noerr, 365 U.S. at 144. Where activity “ostensibly directed toward influencing governmental

action . . . [is] a mere sham to cover what is actually nothing more than an attempt to interfere directly with the business relationships of a competitor[,] . . . the application of the Sherman Act would be justified.” Id. Whether a lawsuit qualifies as a sham requires both an objective and a subjective prong of analysis. Carroll Touch, Inc. v. Electro Mech. Sys., Inc., 15 F.3d 1573, 1582 (Fed. Cir. 1993) (citing Prof. Real Est. Invs., Inc. v. Columbia Pictures Indus., Inc., 508 U.S. 49, 113 (1993)).

The first prong of the sham litigation test states “the lawsuit must be objectively baseless in the sense that no reasonable litigant could realistically expect success on the merits.” Pro. Real Est., 508 U.S. at 60. “If an objective litigant could conclude that the suit is reasonably calculated to elicit a favorable outcome, the suit is immunized under Noerr, and an antitrust claim premised on the sham exception must fail.” Id.

The Court reaches the second prong “[o]nly if [the] challenged litigation is objectively meritless.” Id. Here, the Court “examine[s] the litigant’s subjective motivation . . . [by] focus[ing] on whether the baseless lawsuit conceals ‘an attempt to interfere directly with the business relationships of a competitor’ through the ‘use [of] the governmental process—as opposed to the outcome of that process—as an anticompetitive weapon.’” Id. at 60–61 (internal citations omitted) (emphasis in original).

III. ANALYSIS

A. Initial Considerations

In its Response, Counterclaim Plaintiff first makes a number of non-substantive arguments. (See ECF No. 42 at PageID 463–66.)

First, Counterclaim Plaintiff argues that a motion to dismiss is the wrong stage of litigation to dispose of the sham litigation counterclaim. (Id. at PageID 463.) Counterclaim Plaintiff cites a

variety of district court cases which held the sham litigation exception to Noerr-Pennington immunity was factual in nature and could not be resolved at the motion to dismiss stage, while Counterclaim Defendants cite a number of cases that dispose of sham litigation at this stage. (See id. (collecting cases); ECF No. 56 at PageID 687 (collecting cases).) Ultimately, the Court is not persuaded to dispose of the Motion based on the stage of the litigation; its guide will be to examine if there is “sufficient factual matter, accepted as true, to ‘state a claim to relief that is plausible on its face.’” Iqbal, 556 U.S. at 678 (citing Twombly, 550 U.S. at 570).

Counterclaim Plaintiff then argues because Counterclaim Defendants incorrectly included claim 25 of the '264 Patent and claim 1 of the '224 Patent into their arguments and referred to “Asserted Patents” rather than specific claims within those patents, Counterclaim Defendants’ arguments are “overbroad and should be ignored.” (ECF No. 52 at PageID 465.) The Court will not cast aside Counterclaim Defendants’ arguments based on semantics; to the extent Counterclaim Defendants argue claim 25 of the '264 Patent or that claim 1 of the '224 Patent is valid, those arguments will be ignored. However, the Court will consider the arguments as they pertain to claim 1 of the '368 Patent and claims 16 and 18 of the '264 Patent, as those are the specific claims at issue. (See ECF No. 52 at PageID 465.)

B. Objective Prong

The objective prong requires the lawsuit to “be objectively baseless in the sense that no reasonable litigant could realistically expect success on the merits.” Pro. Real Est., 508 U.S. at 60. Given the stage of litigation, the question is: did Counterclaim Plaintiff sufficiently plead facts as to Counterclaim Defendants’ knowledge of the invalidity of the specified patent claims such that the claims are objectively baseless? See id.; see also ECF No. 52 at PageID 465 (“The question, properly defined, is whether [Counterclaim Plaintiff] has pled sufficient facts to establish that the

[Counterclaim Defendants] lacked a realistic expectation of success on the merits as to claims 16 and 18 of the '264 patent and claim 1 of the '358 patent and nonetheless chose to file those claims in subjective bad faith.”).

Because Counterclaim Plaintiff did not sufficiently plead facts to show Counterclaim Defendants knew the claims were invalid and lacked a realistic expectation of success on the merits, the Court finds that the objective prong of the test is not met.

i. The '358 Patent

Counterclaim Plaintiff alleges that “[Counterclaim Defendants] knew at least claim 1 of the '358 patent was invalid at least upon receiving Leer’s invalidity contentions.” (ECF No. 31 at PageID 218.) This argument is unavailing for two reasons: (1) an allegation of invalidity does not equal a knowledge of invalidity; and (2) there is no knowledge as to validity where the previous case settled.

For the first reason, Counterclaim Plaintiff alleges multiple times in its Amended Counterclaims that Counterclaim Defendants “knew” or were “aware of” the invalidity of claim 1 of the '358 Patent’s based “at least upon . . . Leer’s invalidity contentions.” (*Id.* at PageID 218, 219.) However, invalidity contentions by a competitor are not enough to give Counterclaim Defendants knowledge of invalidity of claim 1 of the '358 Patent. Argus Chem. Corp. v. Fibre Glass-Evercoat Co., 812 F.2d 1381, 1386 (Fed. Cir. 1987) (“The allegation by an accused infringer that the patent is invalid—an assertion frequently made by those charged with infringement—cannot be turned into evidence that the patentee knew the patent was invalid when it instituted an infringement suit.”); see also United Food & Com. Workers Unions & Emps. Midwest Health Benefits Fund v. Novartis Pharms. Corp., No. 15-CV-12732, 2017 WL 2837002, at *11 (D. Mass.

June 30, 2017) (“a merely plausible patent invalidity claim is not enough to support a plausible sham litigation claim”), aff’d, 902 F.3d 1 (1st Cir. 2018).

Indeed, Counterclaim Plaintiff’s argument cuts against the statutory presumption that a patent is valid. See 28 U.S.C. § 282(a).

Counterclaim Plaintiff argues because it has asserted that Counterclaim Defendants “knew the claims were invalid before filing suit,” Counterclaim Defendants are not entitled to a presumption of validity. (ECF No. 52 at PageID 468 (citing Smarte Carte, Inc. v. Innovative Vending Sols. LLC, No. 1:19-CV-08681-NLH-AMD, 2020 WL 5758363, at *5 (D.N.J. Sept. 28, 2020).) This argument is unavailing. As detailed above, Counterclaim Defendants had no “knowledge” that claim 1 of the ’358 Patent was invalid because there was only an allegation of invalidity. Furthermore, Smarte Carte is not persuasive here. In Smarte Carte, the court stated the patentee “should have known that its patent was invalid—and therefore its patent infringement lawsuit objectively baseless—because products embodying the claimed invention were sold in the United States more than one year before the filing of the patent at issue.” 2020 WL 5758363, at *5. There, the allegations of “prior art sales of the patented invention” which invalidated the patent were the inventor’s own sales of the patented invention. (ECF No. 52 at PageID 805, 1:19-cv-08681-ESK-AMD (D.N.J.)) Here, however, Counterclaim Plaintiff alleges the X2T tonneau—an entirely different product which no judicial or administrative body has determined to be invalidating prior art—is enough to give Counterclaim Defendants knowledge of invalidity of claim 1 of the ’358 Patent. (See ECF No. 52 at PageID 469.) That is not enough to show Counterclaim Defendants had knowledge that the patent infringement claims would be objectively baseless. See Pro. Real Est., 508 U.S. at 60. Thus, Counterclaim Plaintiff’s assertion Counterclaim Defendants “knew the claims were invalid” based on the X2T tonneau is not supported by facts;

rather, it is a conclusory assertion which cannot show knowledge of invalidity. See Iqbal, 556 U.S. at 678–79; see also City of Newark v. Delmarva Power & Light Co., 497 F. Supp. 323, 326 (D. Del. 1980) (“requir[ing] a litigant claiming ‘sham’ behavior to state the basis for this allegation in more than conclusory terms”).

For the second reason, the fact that the Leer litigation settled is not enough to give Counterclaim Defendants knowledge of the invalidity of claim 1 of the ’358 Patent. Indeed, “[i]f the initial proceeding results in settlement, the position cannot be viewed as having been successfully asserted.” Edwards v. Aetna Life Ins. Co., 690 F.2d 595, 599 (6th Cir. 1982). Because the Leer litigation ended in settlement, with no disposition as to claim 1 of the ’358 Patent, “[t]he validity of the [’358 P]atent has not been adjudicated by any court (or the [U.S. Patent and Trademark Office] on reexamination).” Braintree Lab’ys, Inc. v. Schwarz Pharma, Inc., 568 F. Supp. 2d 487, 497 (D. Del. 2008). Thus, the Court “has no occasion to judge the merits of Counterclaim Plaintiff’s invalidity arguments, and declines to issue a finding that Counterclaim Defendant[s] should have known of its patent’s invalidity absent such findings.” Id.

Counterclaim Plaintiff’s arguments against this second point are unavailing as well. The fact that the Delaware District Court in the Leer litigation denied a partial motion for summary judgment to disqualify the X2T tonneau as prior art does not mean Counterclaim Defendants knew the X2T tonneau invalidated claim 1 of the ’358 Patent. (See ECF No. 31 at PageID 218.) Whether the X2T tonneau could be considered invalidating prior art was “a matter for trial,” where “a jury may choose to disbelieve . . . the . . . evidence.” (ECF No. 238 at PageID 12410, 1:19-cv-00923-KAJ (D. Del.)) The X2T tonneau could be invalidating prior art; however, that possibility does not equate to certainty or knowledge of invalidity because reasonable minds could differ on that conclusion. See Henschel v. Clare Cnty. Rd. Comm’n, 737 F.3d 1017, 1022 (6th Cir. 2013)

(“Where there is a genuine issue of material fact, summary judgment is not appropriate. . . . A genuine issue for trial exists where reasonable minds could differ on a material fact.”).

Because the Court finds that Counterclaim Plaintiff did not adequately plead knowledge or awareness of the invalidity of claim 1 of the '358 Patent, it does not rely on Counterclaim Defendants' arguments that they survived a summary judgment motion on invalidity in the Leer litigation,⁴ or the fact that the International Trade Commission litigation settlement “in [their] favor.”⁵ (ECF No. 42 at PageID 281.)

ii. The '264 Patent

Counterclaim Plaintiff alleges “[Counterclaim Defendants] knew . . . the '264 Patent [was] invalid in light of Leer’s invalidity case[, and] specifically . . . claims 16 and 18 of the '264 Patent were invalid in light of their prior 2012 to 2014 [BAK] litigation, in which UnderCover and RealTruck’s predecessor in interest each argued those claims were invalid.” (ECF No. 31 at PageID 218.)

Because Counterclaim Plaintiff’s Leer invalidity argument for the '264 Patent is the same as its invalidity argument same as to the '358 Patent, the Court comes to the same conclusion as

⁴ Counterclaim Plaintiff notes that “Leer did not affirmatively move for summary judgment on claim 1 of the '358 patent and presented no argument for one.” (ECF No. 52 at PageID 470.) Indeed, Leer made no indication of its intent to move for summary judgment on invalidity of any claims of the '358 Patent, and the court there denied summary judgment without any analysis. (See ECF No. 159 at PageID 6565, 1:19-cv-00923-KAJ (D. Del.); ECF No. 236 at PageID 12384 n.1, 1:19-cv-00923-KAJ (D. Del.).)

⁵ The Court is unpersuaded by the citation to Toyo Tire & Rubber Co., Ltd. v. CIA Wheel Group, No. 15-246, 2015 WL 4545187 (C.D. Cal. July 8, 2015). Unlike in Toyo Tire, where the defendant stipulated that the ITC proceeding settled in the patentee’s favor, here Counterclaim Plaintiff disputes whether the ITC settlement was favorable towards Counterclaim Defendants. *Id.* at *3. In order to resolve this, the Court would have to try to parse through claim 1 of the '358 Patent with the variety of other patents, which it declines to do given the strength of the other arguments.

above and finds that Counterclaim Defendants did not have knowledge or awareness of the invalidity of the '264 Patent from Leer's invalidity contentions. See supra Section III.B.i.

Moving to the BAK litigation argument, Counterclaim Plaintiff asserts that in the BAK litigation, "UnderCover and RealTruck repeatedly asserted that claims 16 and 18 of the '264 patent were invalid," "fil[ing] a series of pleadings, motions, and papers asserting invalidity of those claims[—]each subject to Rule 11." (ECF No. 52 at PageID 466.) Counterclaim Plaintiff alleges since then, Counterclaim Defendants have "avoided asserting claims 16 and 18 of the '264 patent in lawsuits." (Id. (citing ECF No. 31 at PageID 215).)

However, mere assertions of invalidity in the context of litigation are not enough to confer knowledge of invalidity on Counterclaim Defendants. See Argus Chem., 812 F.2d at 1386; see also United Food, 2017 WL 2837002, at *11. Like claim 1 of the '358 Patent, claims 16 and 18 of the '264 Patent have not been found to be invalid. Because the BAK litigation ended in a settlement, Counterclaim Defendants cannot be said to know that the claims at issue are invalid. See Edwards, 690 F.2d at 599; see also Braintree Lab'ys, 568 F. Supp. 2d at 497. Furthermore, the fact that Counterclaim Defendants have not asserted the claims for the past decade is not indicative of their knowledge of invalidity of the claims. Even if Counterclaim Defendants have not asserted these claims because they may subjectively think the claims are "weak," that does not mean the claims are objectively baseless. Braintree Lab'ys, 568 F. Supp. 2d at 497.

iii. Conclusion on Objective Prong

Counterclaim Plaintiff has not sufficiently pled facts to demonstrate that Counterclaim Defendants knew or were aware of the invalidity of claim 1 of the '358 Patent and claims 16 and 18 of the '264 Patent. Because it based its sham litigation argument on these two patents, (see ECF No. 52 at PageID 467), Counterclaim Plaintiff has not proven that the "infringement action was

‘so baseless that no reasonable litigant could realistically expect to secure favorable relief.’” Carroll Touch, 15 F.3d at 1583 (quoting Pro. Real Est., 508 U.S. at 62). Thus, the objective prong is not met. See id. at 1583–84.

C. Subjective Prong

Because the Court finds that the objective prong of the sham litigation exception to the Noerr-Pennington doctrine is not met, it does not reach the subjective prong. See Pro. Real Est., 508 U.S. at 60 (“Only if challenged litigation is objectively meritless may a court examine the litigant’s subjective motivation.”).

IV. CONCLUSION⁶

For the reasons discussed above, the Court finds that Counterclaim Plaintiff has not pled sufficient facts to state a claim upon which relief can be granted. Thus, Counterclaim Defendants’ Motion to Dismiss as to Count VII of Rough Country’s Counterclaims is **GRANTED**. Furthermore, Counterclaim Plaintiff’s Motion for Leave to File a Sur-Reply is **DISMISSED AS MOOT**.

SO ORDERED, this 25th day of November, 2024.

/s/ Jon P. McCalla

JON P. MCCALLA
UNITED STATES DISTRICT COURT JUDGE

⁶ Because Counterclaim Defendants’ claims fall under Noerr-Pennington immunity, the Court does not reach the substantive elements of Counterclaim Plaintiff’s Sherman Antitrust Act § 2 argument. (See ECF No. 52 at PageID 459–61.)