

# **EXHIBIT D**



(12) **United States Patent**  
**Dean et al.**

(10) **Patent No.:** **US 7,249,059 B2**  
(45) **Date of Patent:** **Jul. 24, 2007**

(54) **INTERNET ADVERTISING SYSTEM AND METHOD**

(76) Inventors: **Michael A. Dean**, 6610 Regal Bluff, Dallas, TX (US) 75240; **Lucinda Stone**, 6610 Regal Bluff, Dallas, TX (US) 75240

(\* ) Notice: Subject to any disclaimer, the term of this patent is extended or adjusted under 35 U.S.C. 154(b) by 581 days.

(21) Appl. No.: **10/193,465**

(22) Filed: **Jul. 11, 2002**

(65) **Prior Publication Data**  
US 2002/0178093 A1 Nov. 28, 2002

**Related U.S. Application Data**

(63) Continuation-in-part of application No. 09/480,303, filed on Jan. 10, 2000, now Pat. No. 6,446,045.

(51) **Int. Cl.**  
**G06F 17/60** (2006.01)

(52) **U.S. Cl.** ..... **705/26**

(58) **Field of Classification Search** ..... **705/26, 705/28, 27, 2**  
See application file for complete search history.

(56) **References Cited**

**U.S. PATENT DOCUMENTS**

5,193,056 A	3/1993	Boes	
5,214,793 A	5/1993	Conway et al.	
5,233,423 A	8/1993	Jernigan et al.	
5,543,856 A *	8/1996	Rosser et al. ....	348/578
5,581,461 A	12/1996	Coll et al.	
5,684,918 A	11/1997	Abecassis	
5,724,520 A	3/1998	Goheen	
5,794,207 A	8/1998	Walker et al.	

5,797,126 A	8/1998	Helbling et al.	
5,845,261 A *	12/1998	McAbian .....	705/26
5,878,141 A	3/1999	Daly et al.	
5,884,277 A	3/1999	Khosla	
5,893,076 A	4/1999	Hafner et al.	
5,933,811 A *	8/1999	Angles et al. ....	705/14
5,946,646 A	8/1999	Schena et al.	
5,991,735 A	11/1999	Gerace	

(Continued)

**FOREIGN PATENT DOCUMENTS**

JP 4082494260 9/1995

**OTHER PUBLICATIONS**

Presstime Magazine, NEXPO 97 Report, Copyright 1997, Newspaper of America.\*

(Continued)

*Primary Examiner*—Florian (Ryan) Zeender

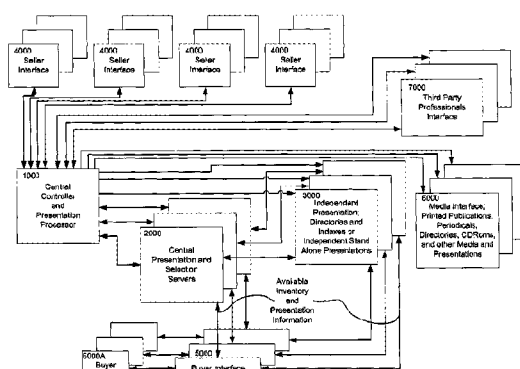
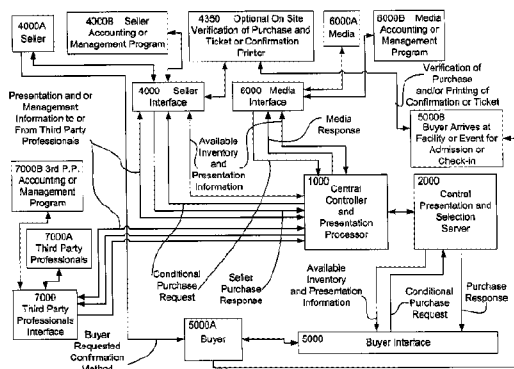
*Assistant Examiner*—O. Garcia Ade

(74) *Attorney, Agent, or Firm*—Henry Croskell

(57) **ABSTRACT**

An internet advertising system and method that enables a third party professional to manage the creation, publication, and display of advertisements on internet media venues owned or controlled by entities other than the seller and other than the third party professional in a form automatically modified to comply with the media venues' presentation rules, which may include design or style standards for "look and feel," editorial standards, and distribution factors. Self-serve, menu driven interfaces are provided for third party professionals to target internet media venues, and for internet media venues to enter their presentation rules. An ad modification engine processes or customizes the advertisement for publication and display on each internet media venue in compliance with the media venue's presentation rules.

**52 Claims, 55 Drawing Sheets**



**US 7,249,059 B2**

Page 2

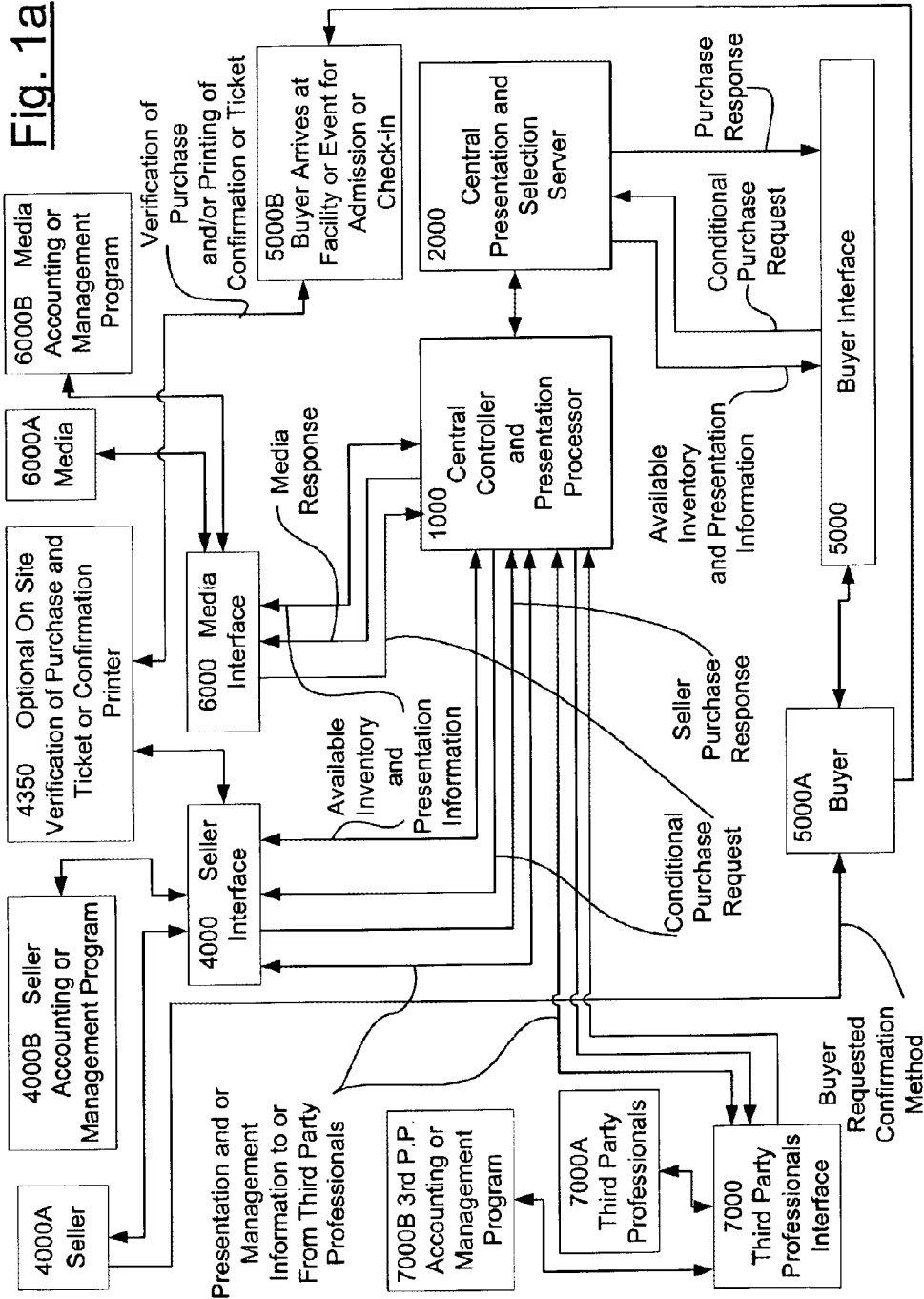
U.S. PATENT DOCUMENTS

6,023,658	A *	2/2000	Jelliyes .....	702/16	6,460,036	B1	10/2002	Herz
6,026,371	A	2/2000	Beck et al.		6,466,975	B1	10/2002	Sterling
6,038,545	A	3/2000	Mandberg et al.		6,487,538	B1	11/2002	Gupta et al.
6,064,967	A	5/2000	Speicher		6,526,575	B1	2/2003	McCoy et al.
6,073,105	A	6/2000	Sutcliffe et al.		6,553,178	B2	4/2003	Abecassis
6,112,192	A	8/2000	Čapek		6,560,578	B2	5/2003	Eldering
6,119,101	A *	9/2000	Peckover .....	705/26	6,567,854	B1	5/2003	Olshansky et al.
6,138,142	A	10/2000	Linsk		6,654,725	B1	11/2003	Langheinrich et al.
6,167,382	A *	12/2000	Sparks et al. ....	705/26	6,718,551	B1	4/2004	Swiz et al.
6,182,050	B1	1/2001	Ballard		6,785,661	B1 *	8/2004	Mandler et al. ....
6,191,780	B1	2/2001	Martin et al.		6,889,382	B1	5/2005	Anderson
6,263,317	B1 *	7/2001	Sharp et al. ....	705/26	6,892,226	B1	5/2005	Tso et al.
6,285,987	B1	9/2001	Roth et al.		6,931,591	B1	8/2005	Brown et al.
6,324,519	B1	11/2001	Eldering		2001/0011226	A1	8/2001	Grear et al.
6,366,682	B1 *	4/2002	Holliman et al. ....	382/115				
6,385,592	B1	5/2002	Angles et al.					
6,397,246	B1	5/2002	Wolfc					
6,401,075	B1	6/2002	Mason et al.					
6,430,603	B2	8/2002	Hunter					
6,430,605	B2	8/2002	Hunter					
6,442,577	B1	8/2002	Britton et al.					
6,446,045	B1 *	9/2002	Stone et al. ....	705/26				

OTHER PUBLICATIONS

www.nationwideadvertising.com About 65 pages taken from the web site as of Mar. 27, 2003.  
 Kenneth S. Roberts, Declaration, Document, Feb. 10, 2006, 2 Pages.  
 "Groups Set to Unveil Web Guidelines" Dec. 9, 1996 Advertising Age, vol. 67, No. 50, p. 1.

\* cited by examiner



**Fig. 1b**

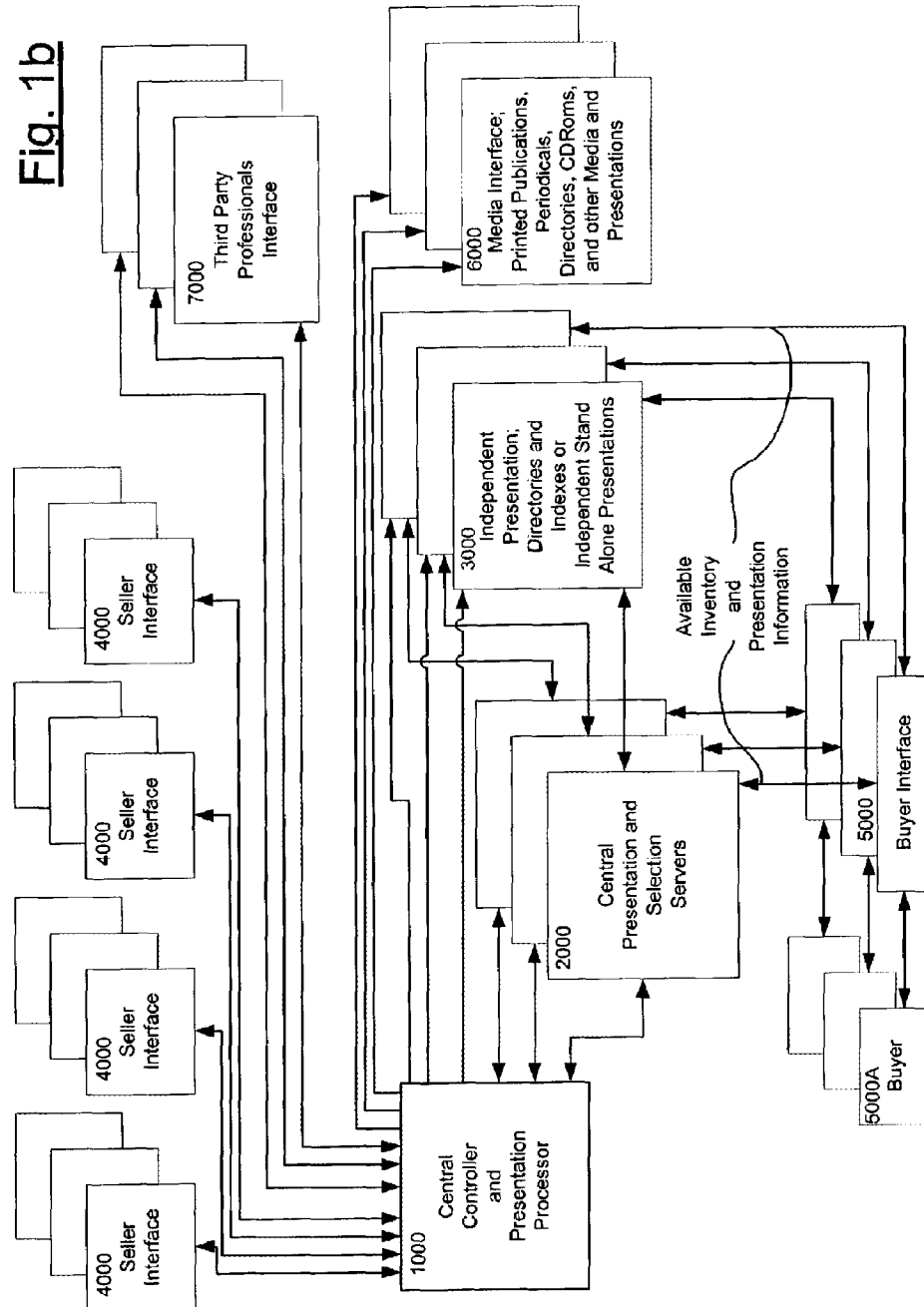
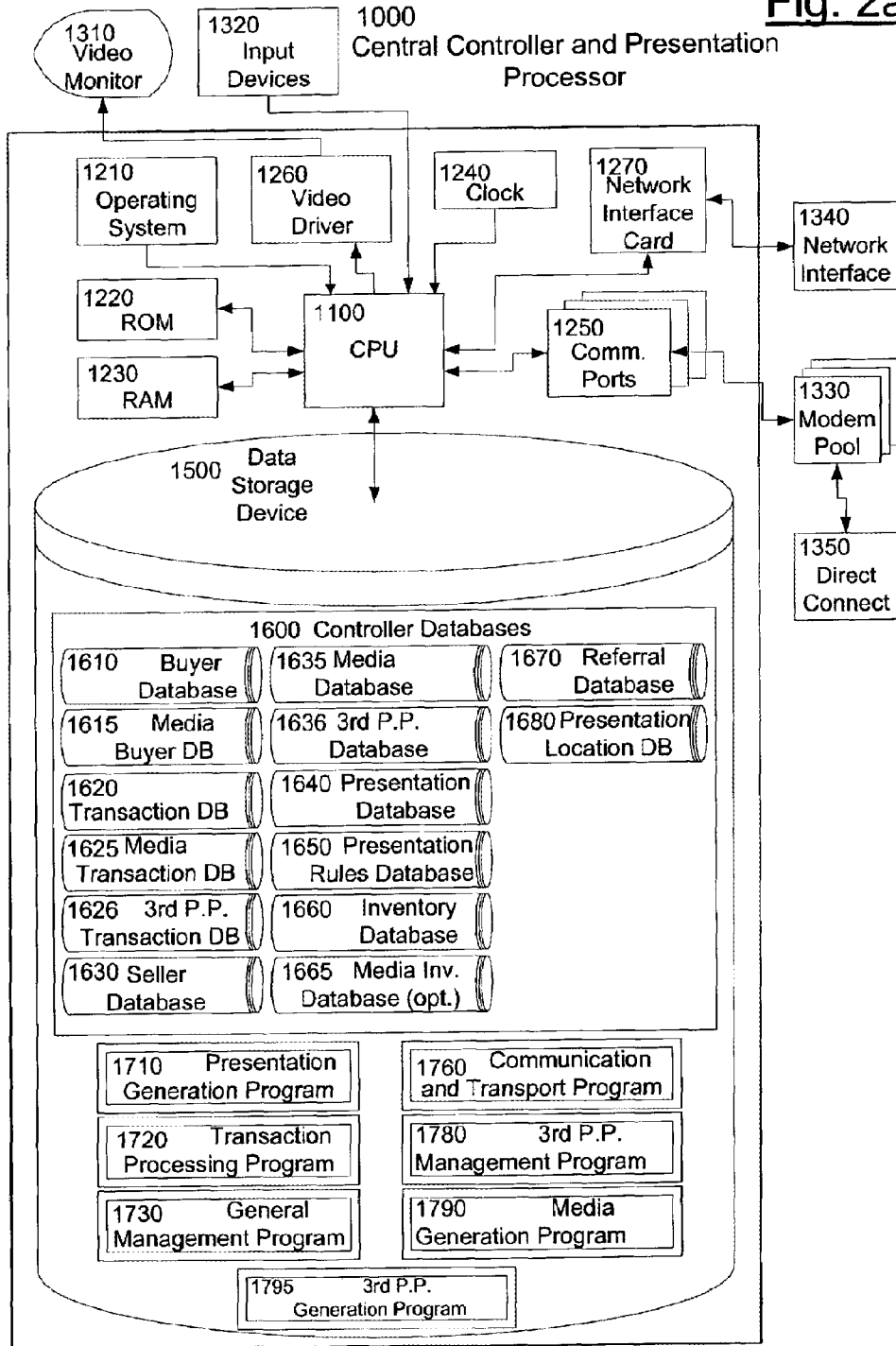


Fig. 2a



**Fig. 2b**

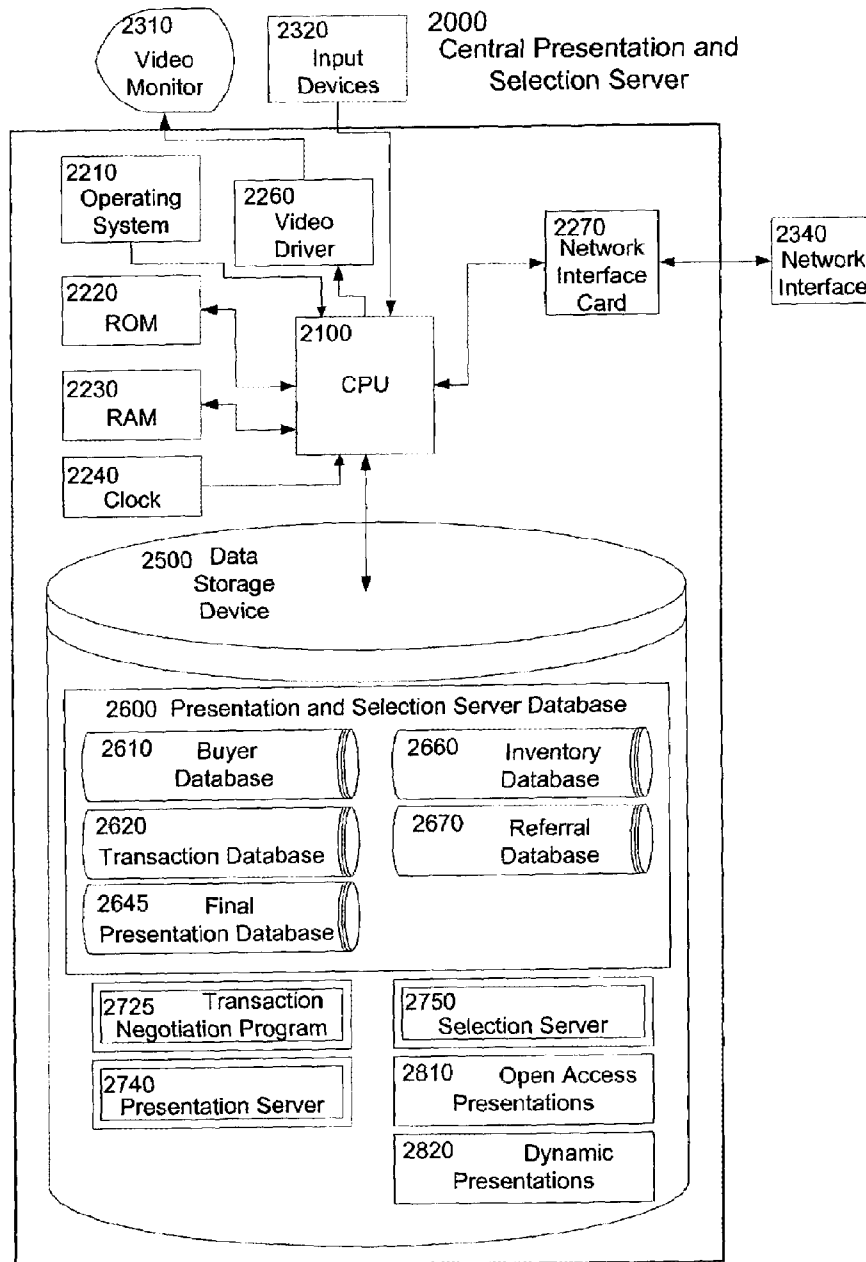


Fig. 2c

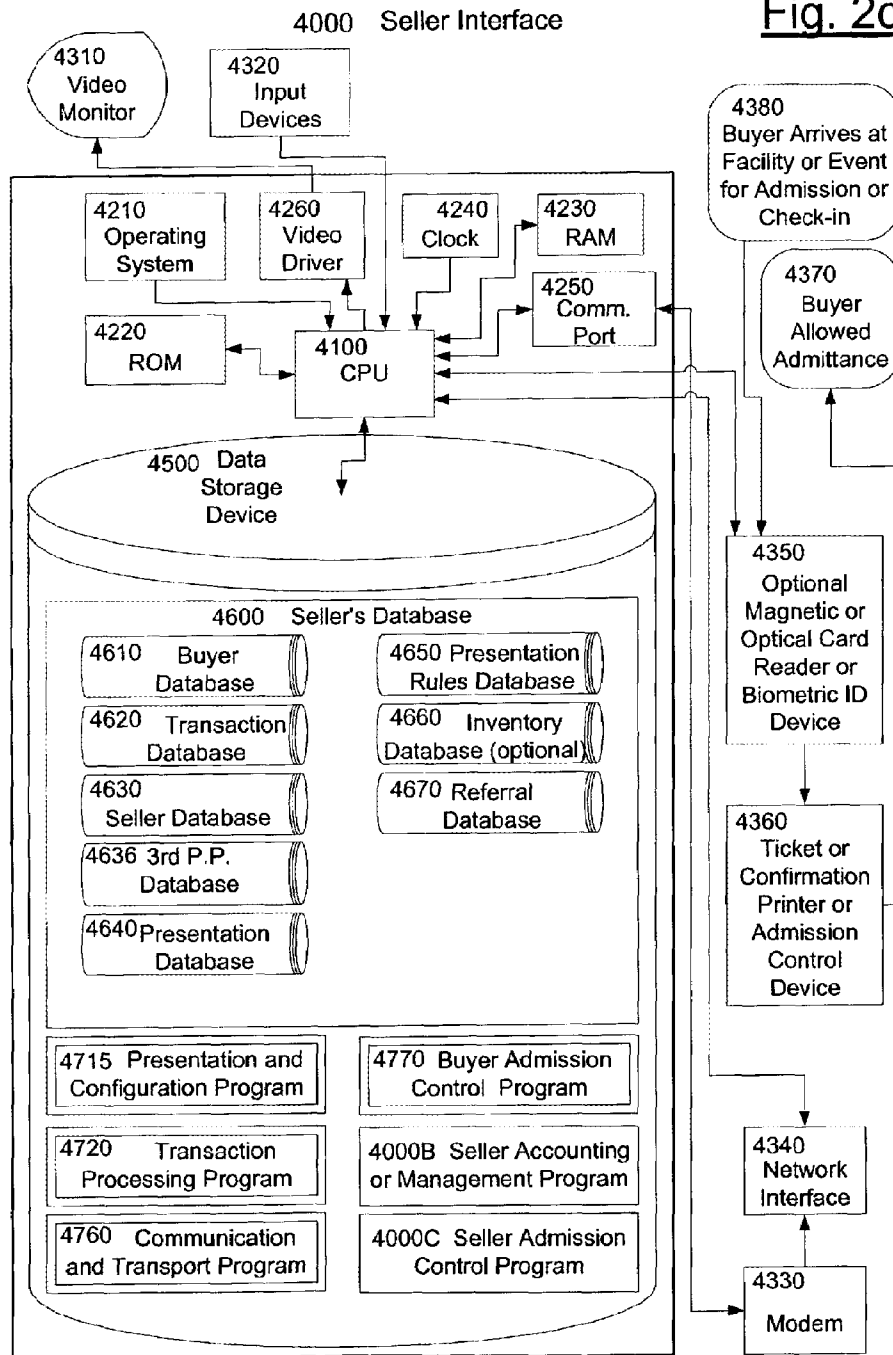




Fig. 2d

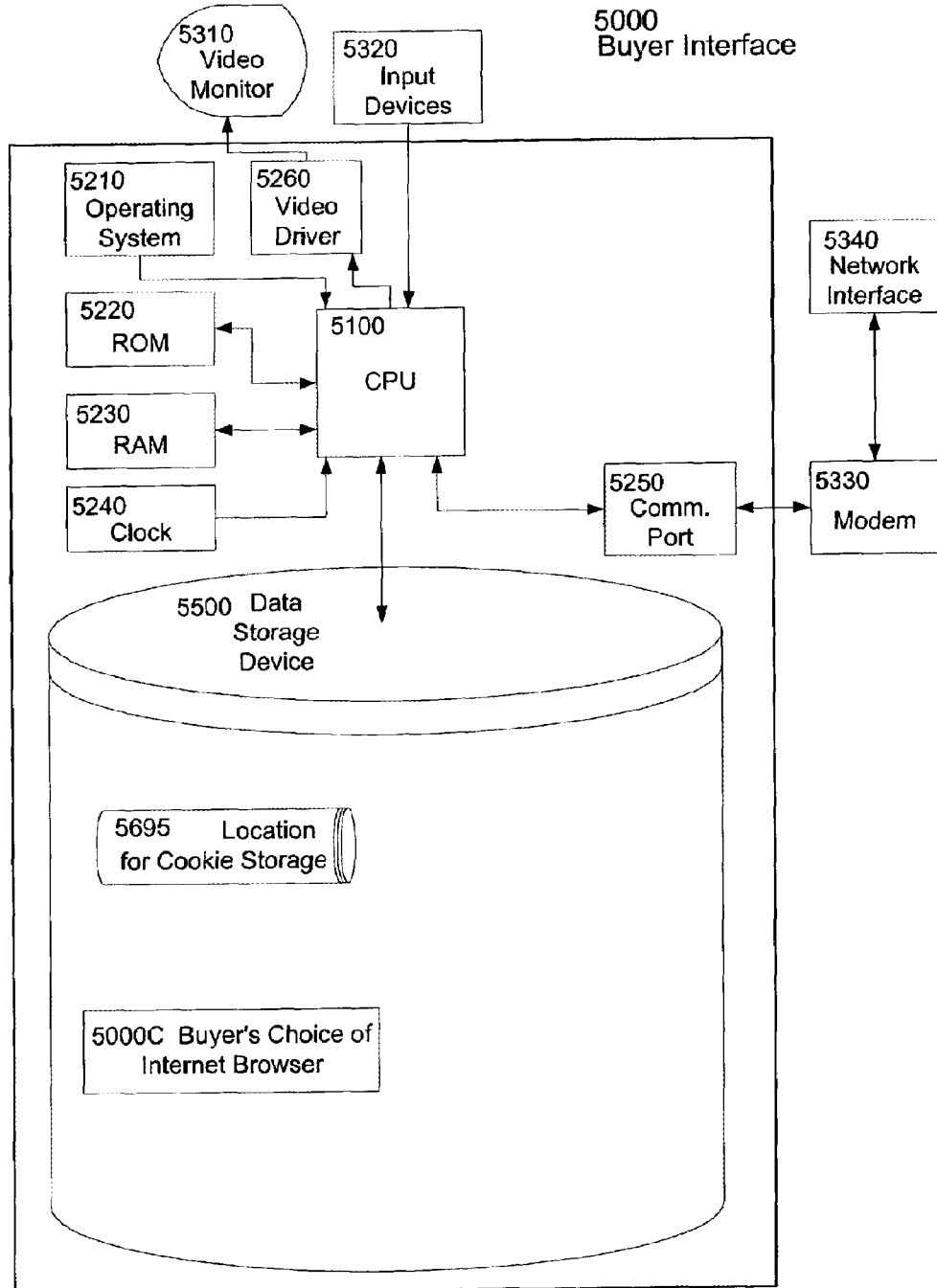
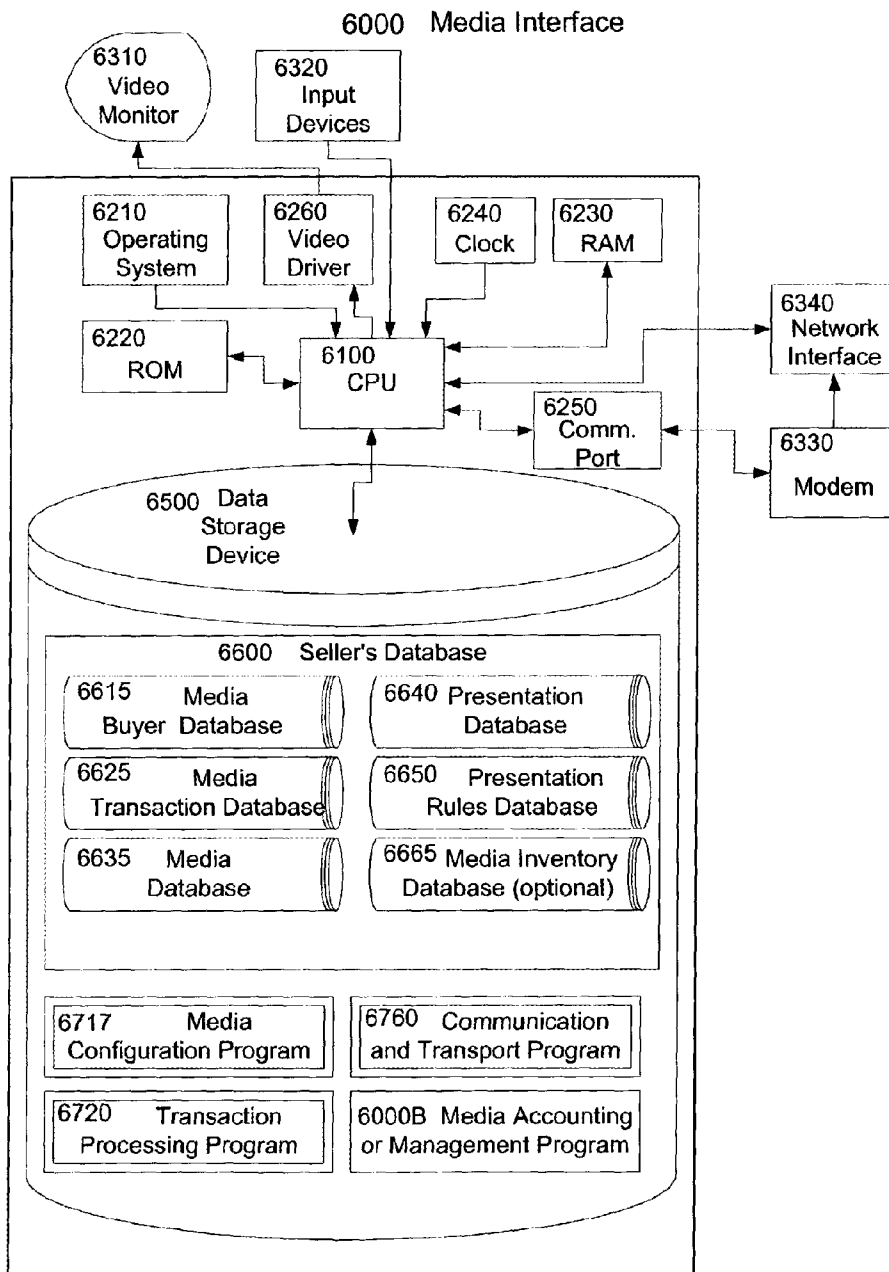


Fig. 2e



7000 Third Party Professional Interface (3rd P.P.)

Fig. 2f

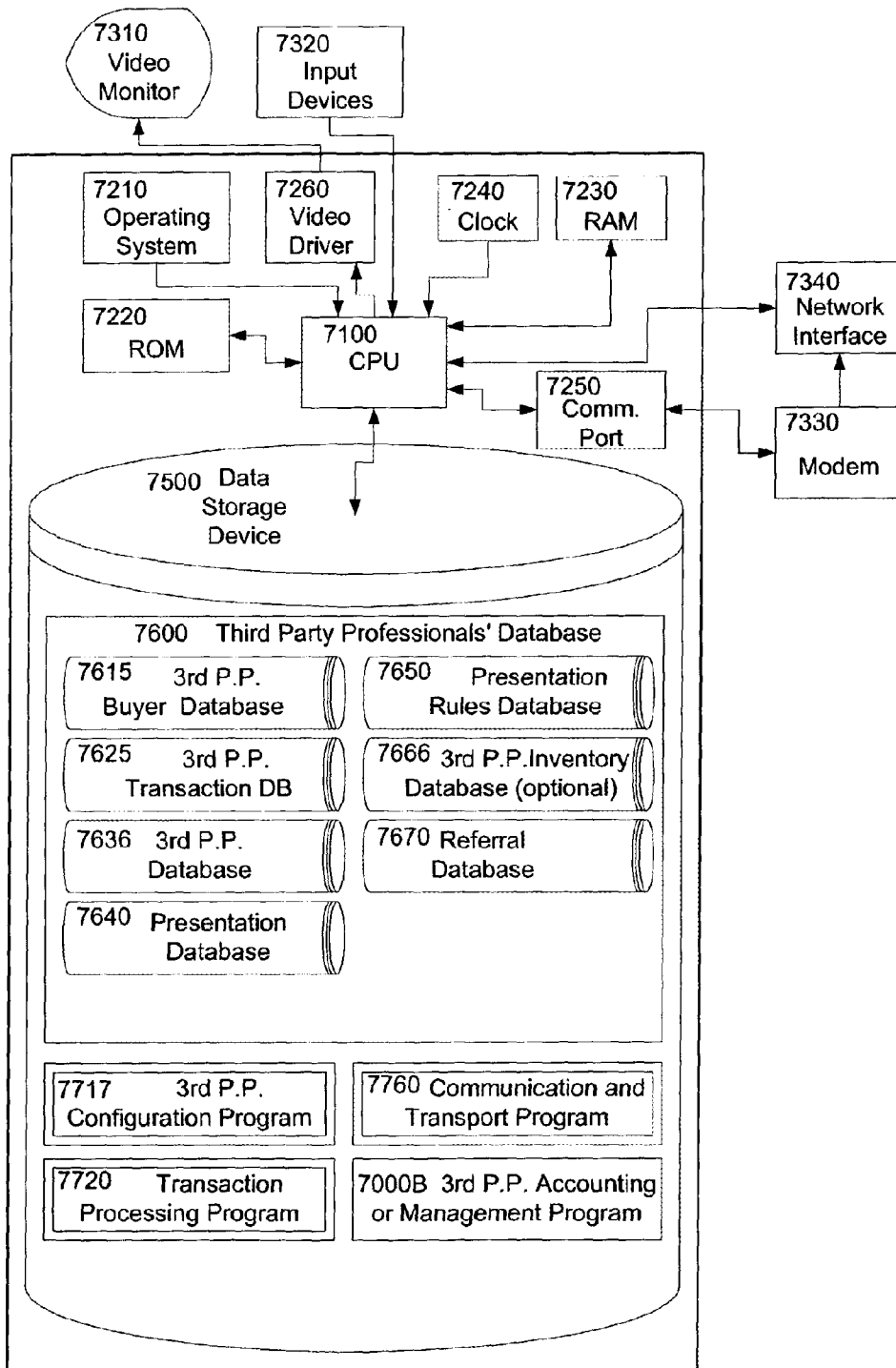


Fig. 3a

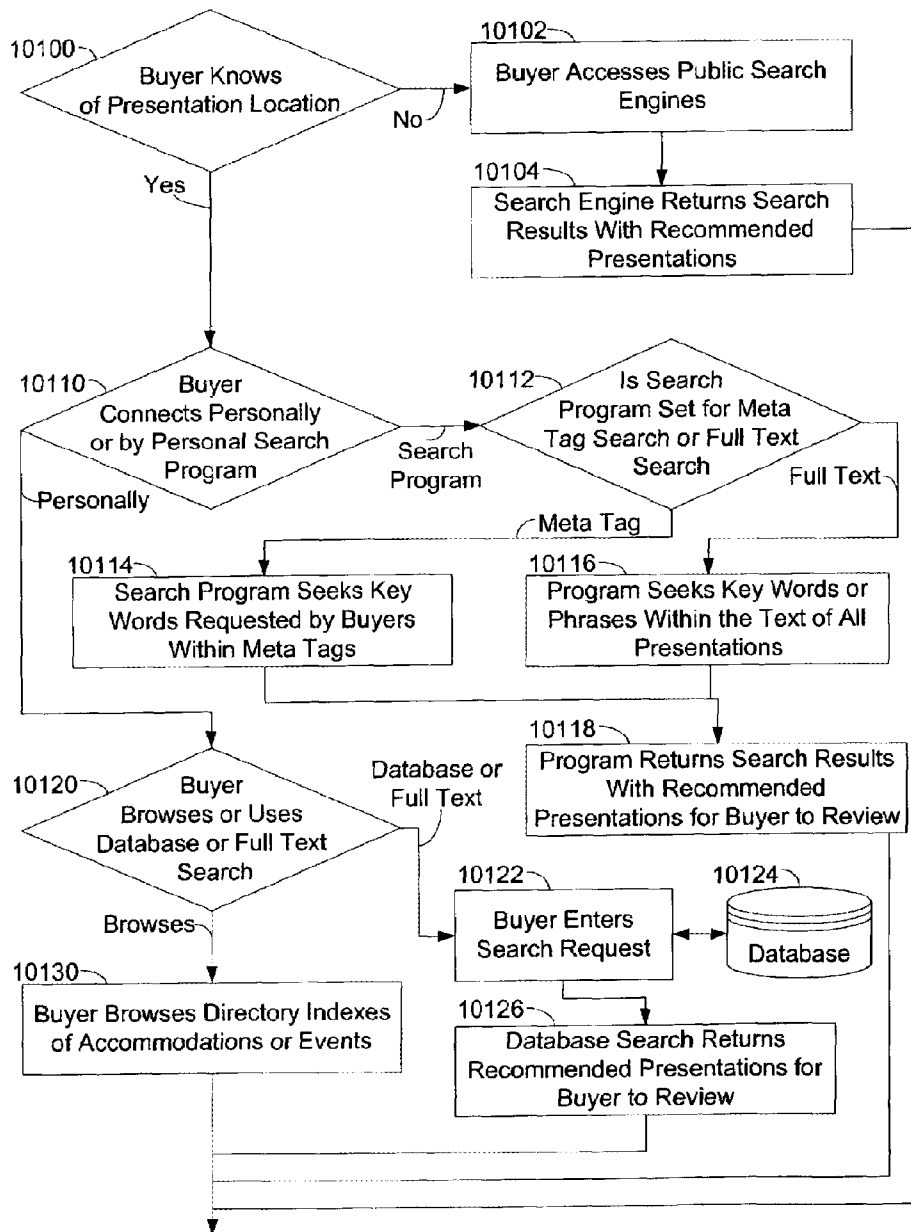


Fig. 3b

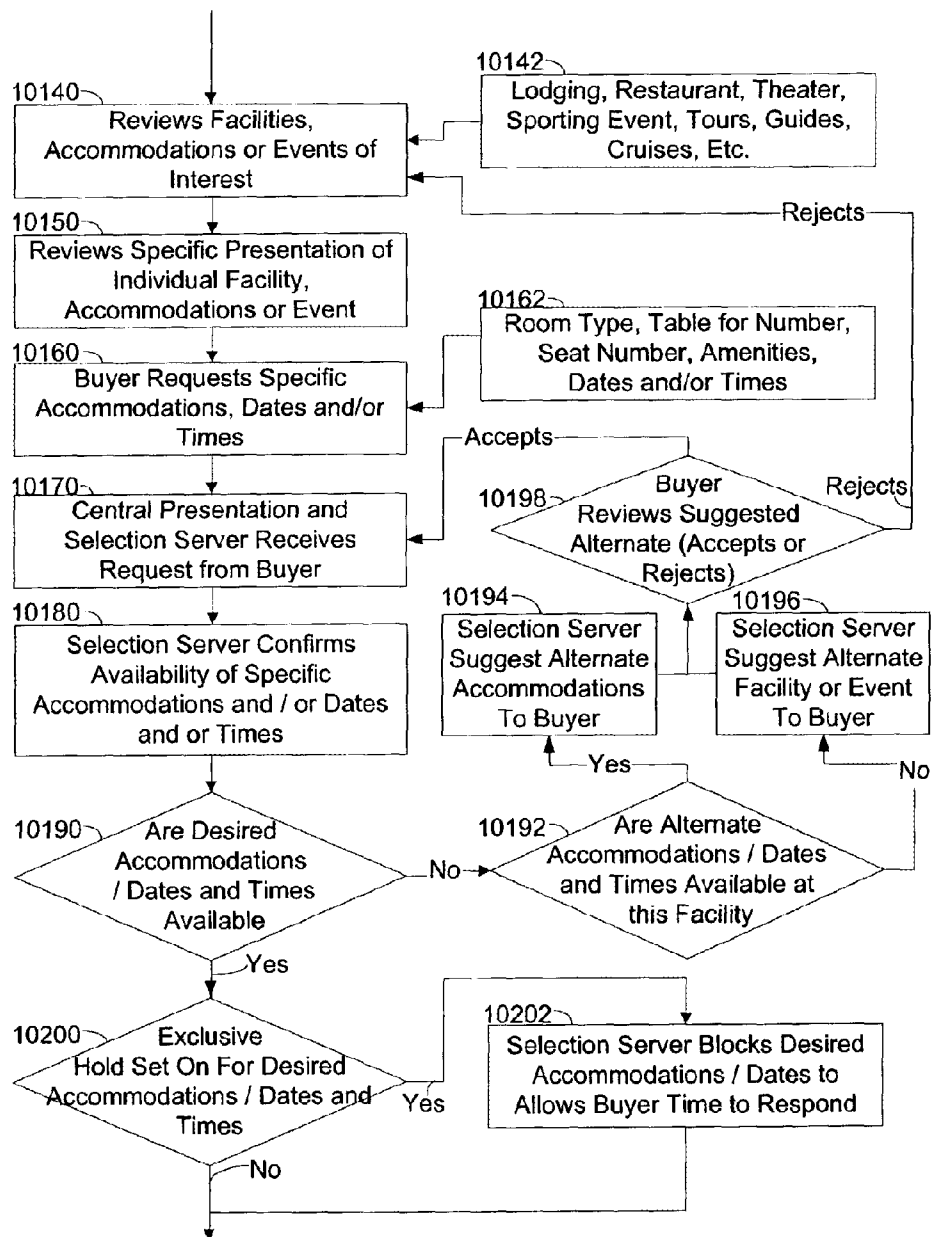


Fig. 3c

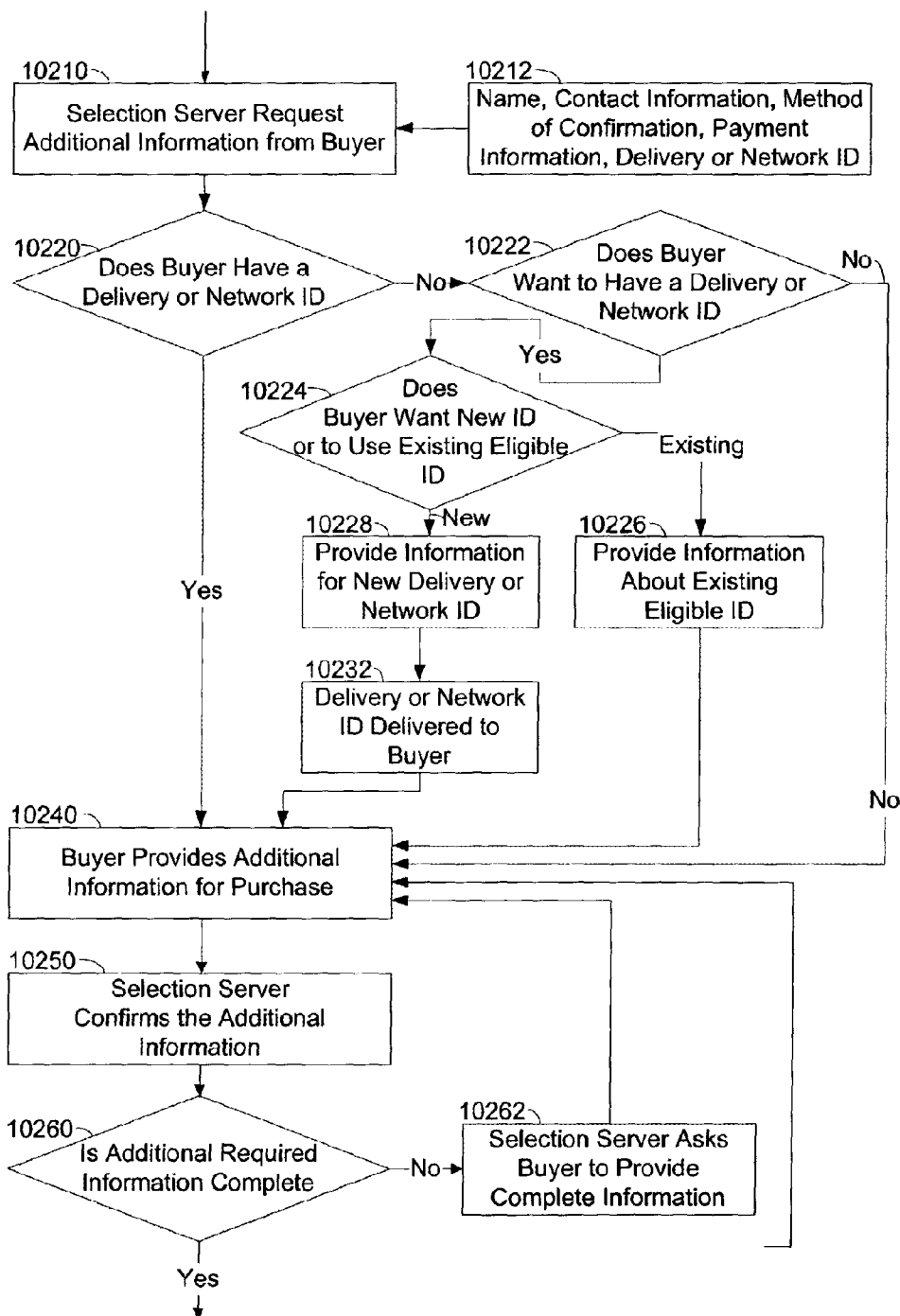
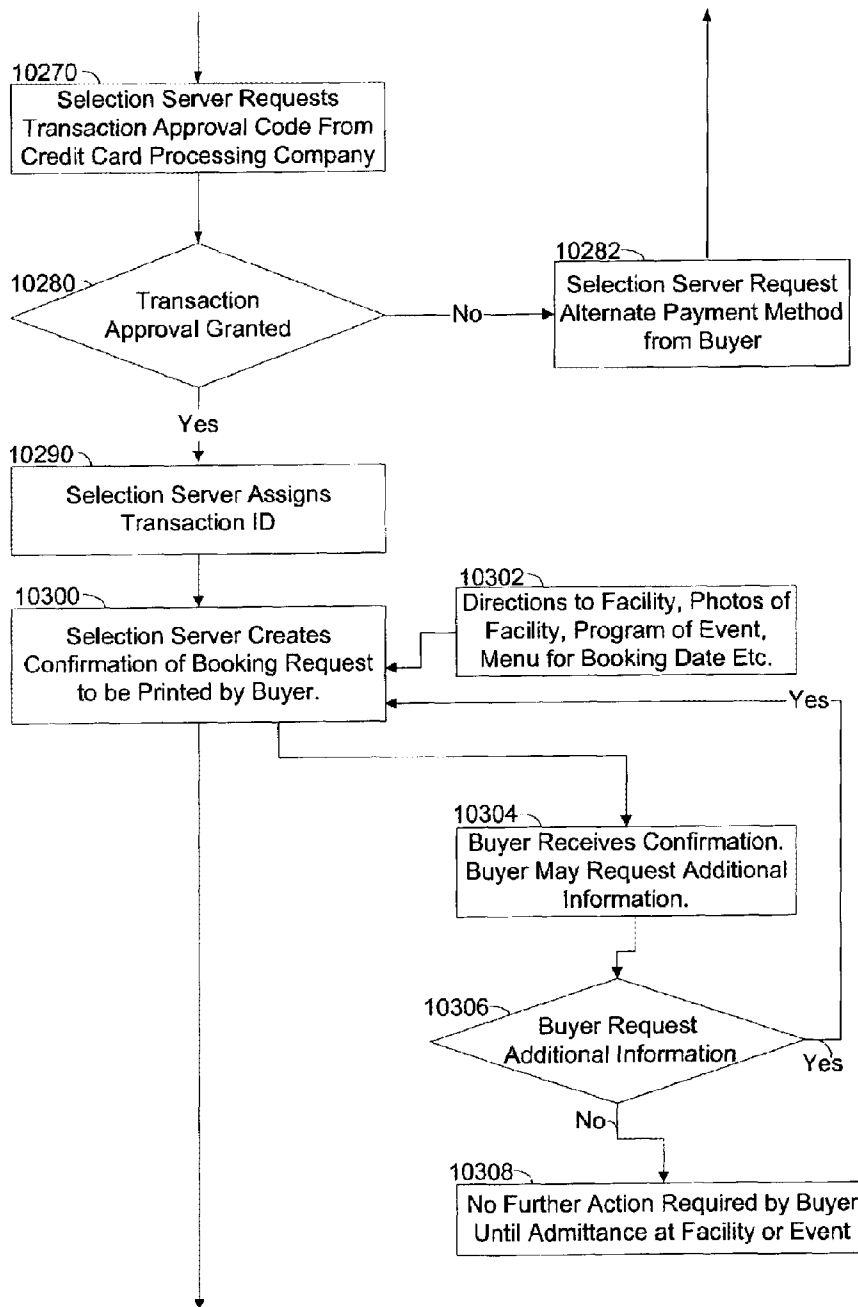
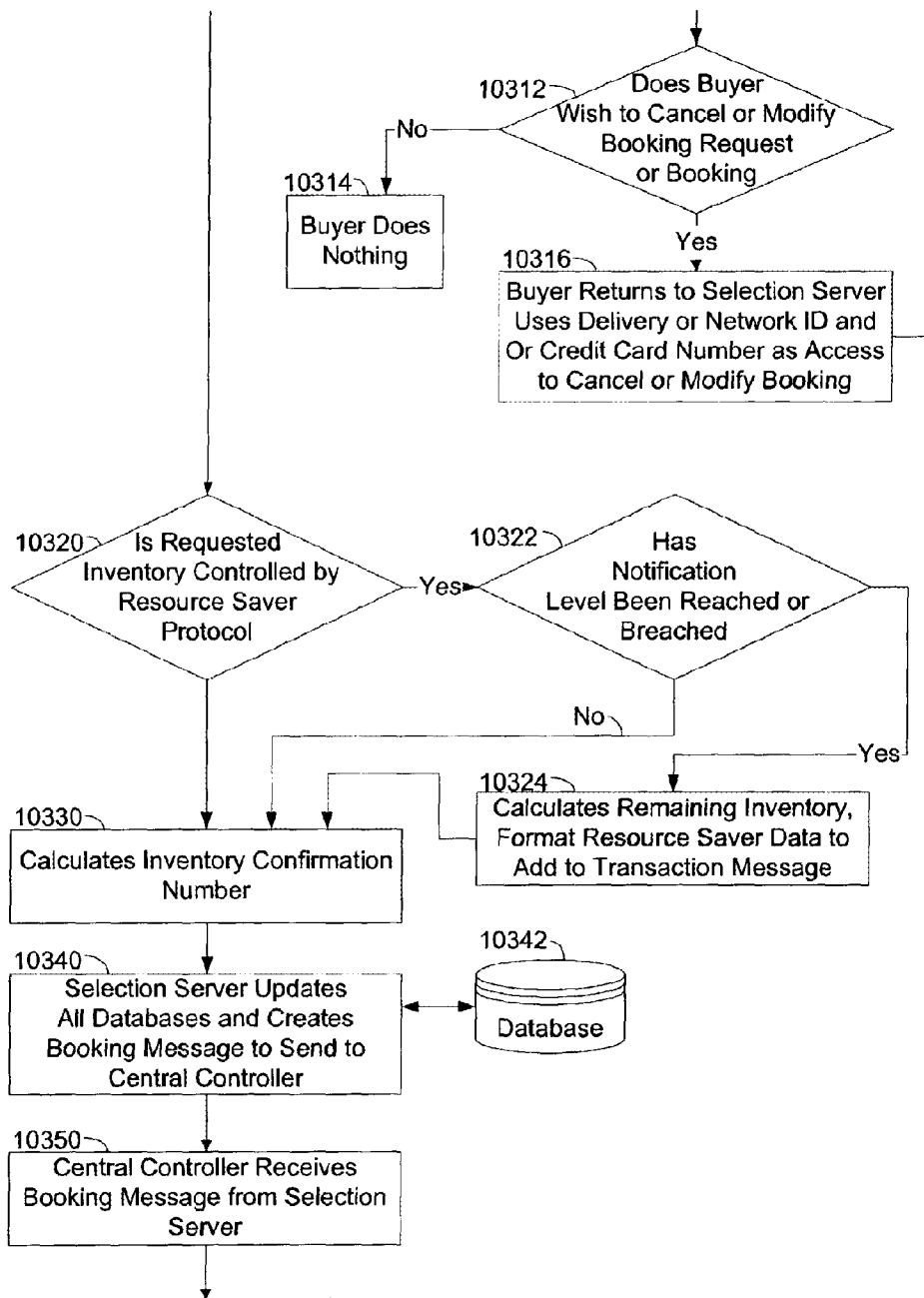


Fig. 3d



**Fig. 3e**





**Fig. 3f**

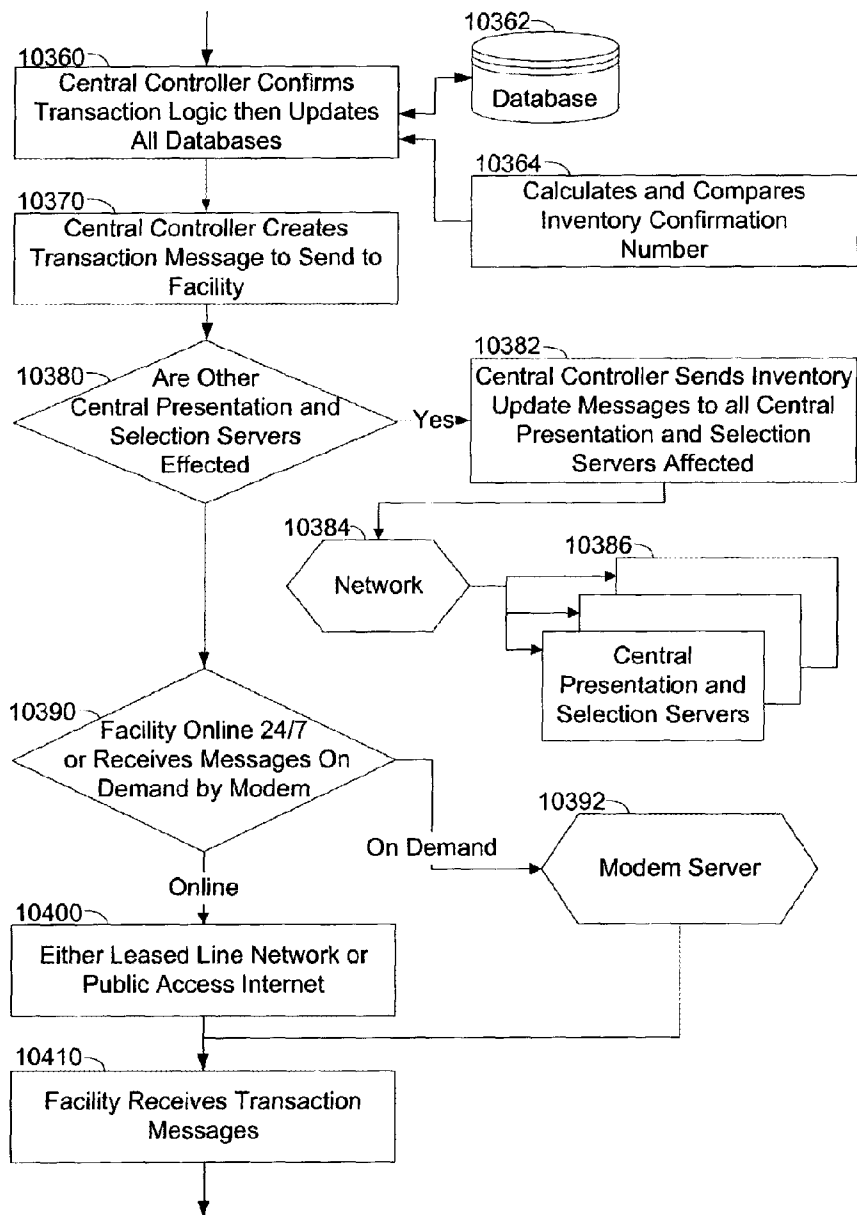


Fig. 3g

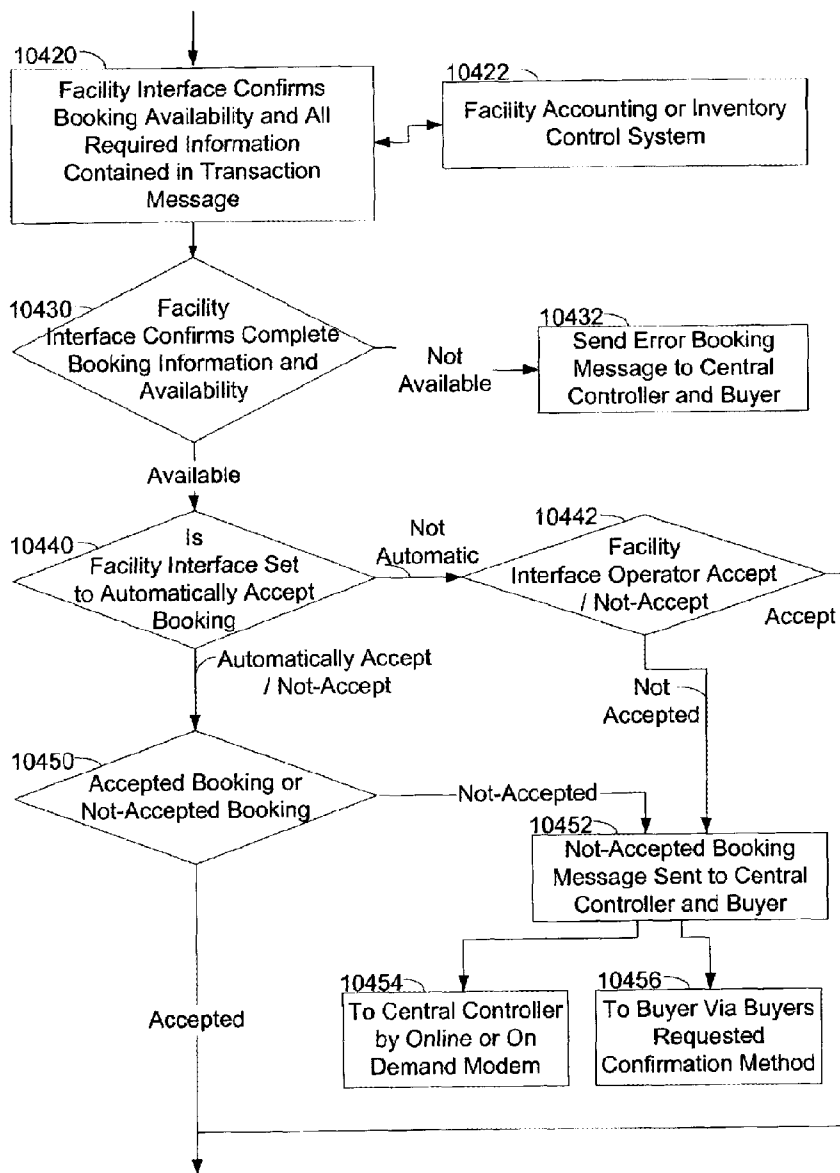


Fig. 3h

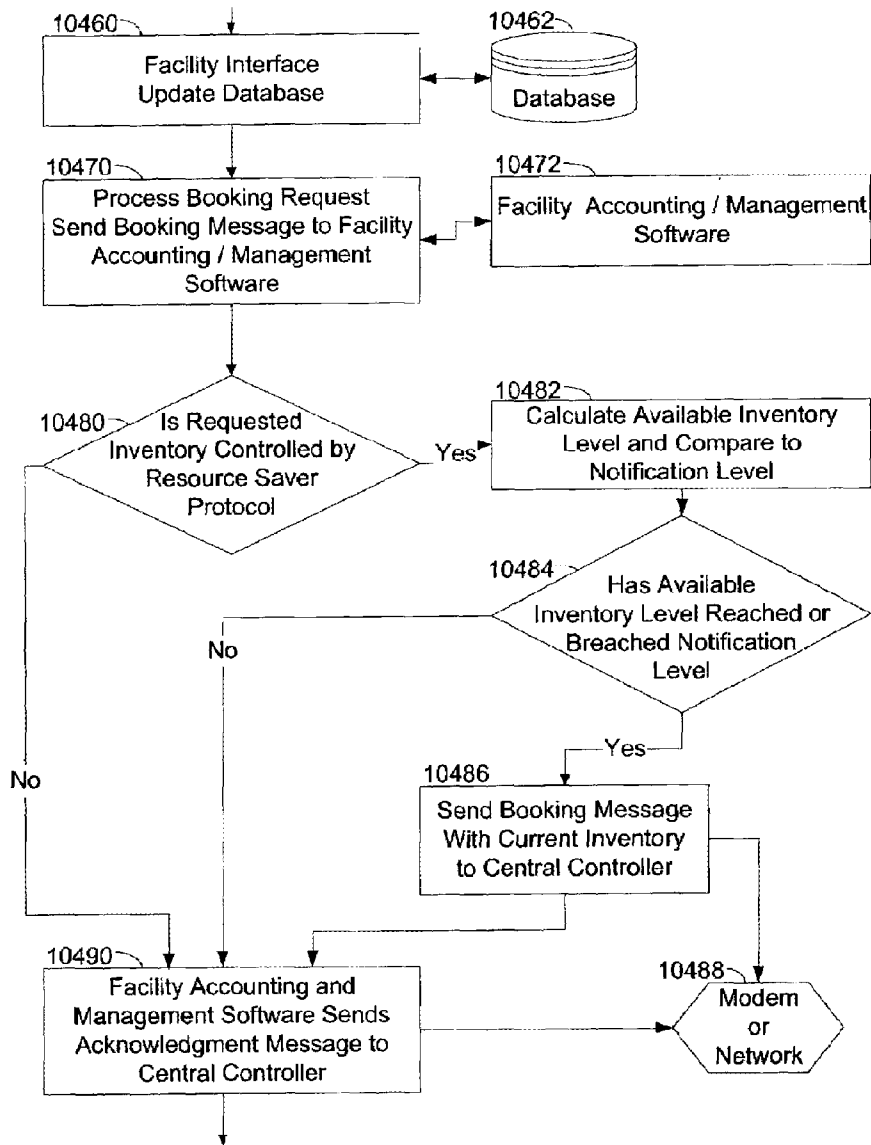


Fig. 3i

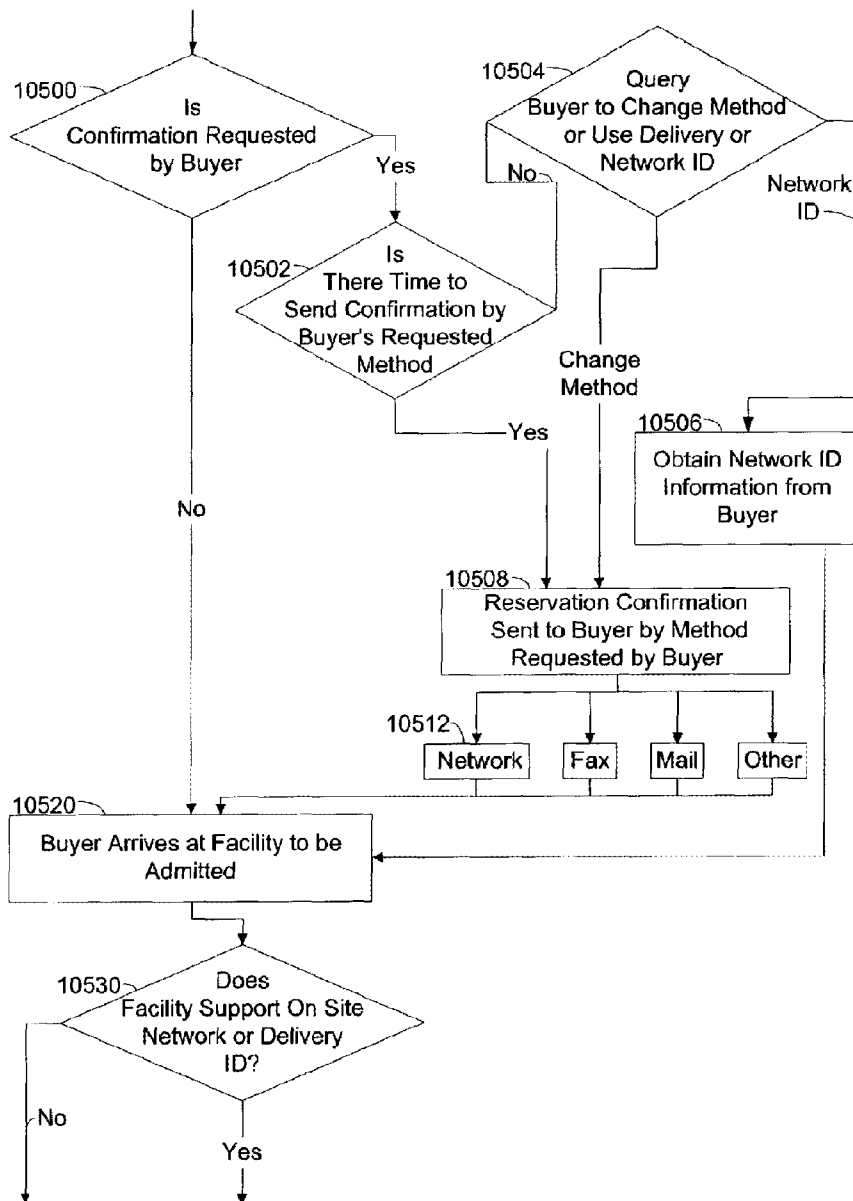


Fig. 3i-a

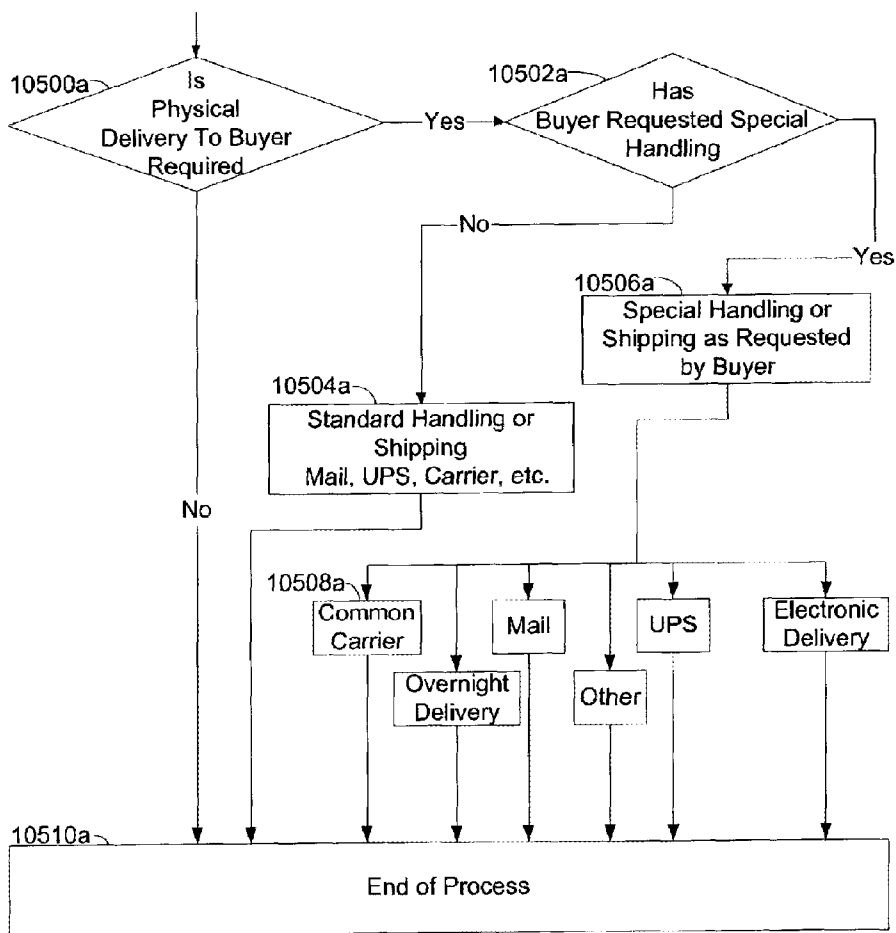
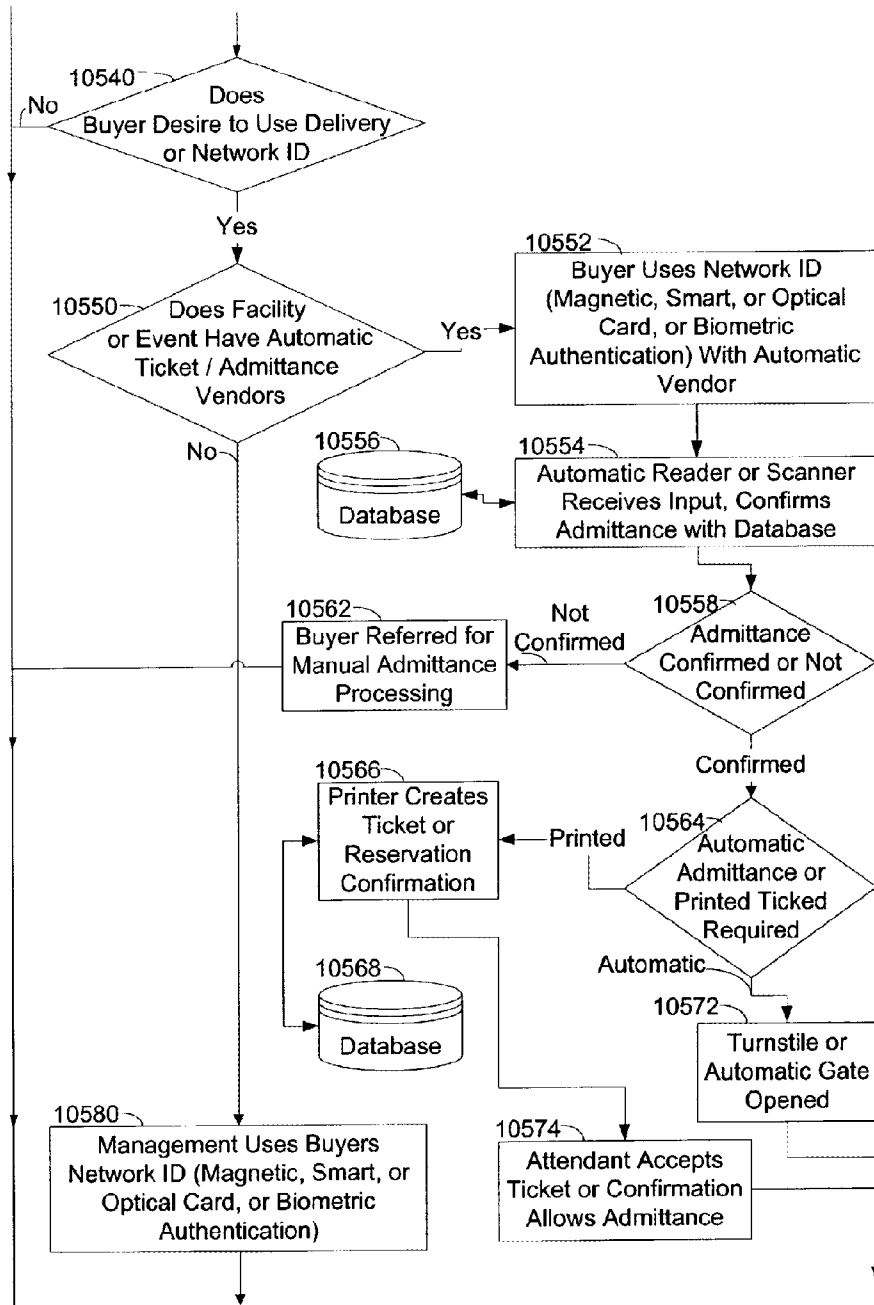


Fig. 3j



**Fig. 3k**

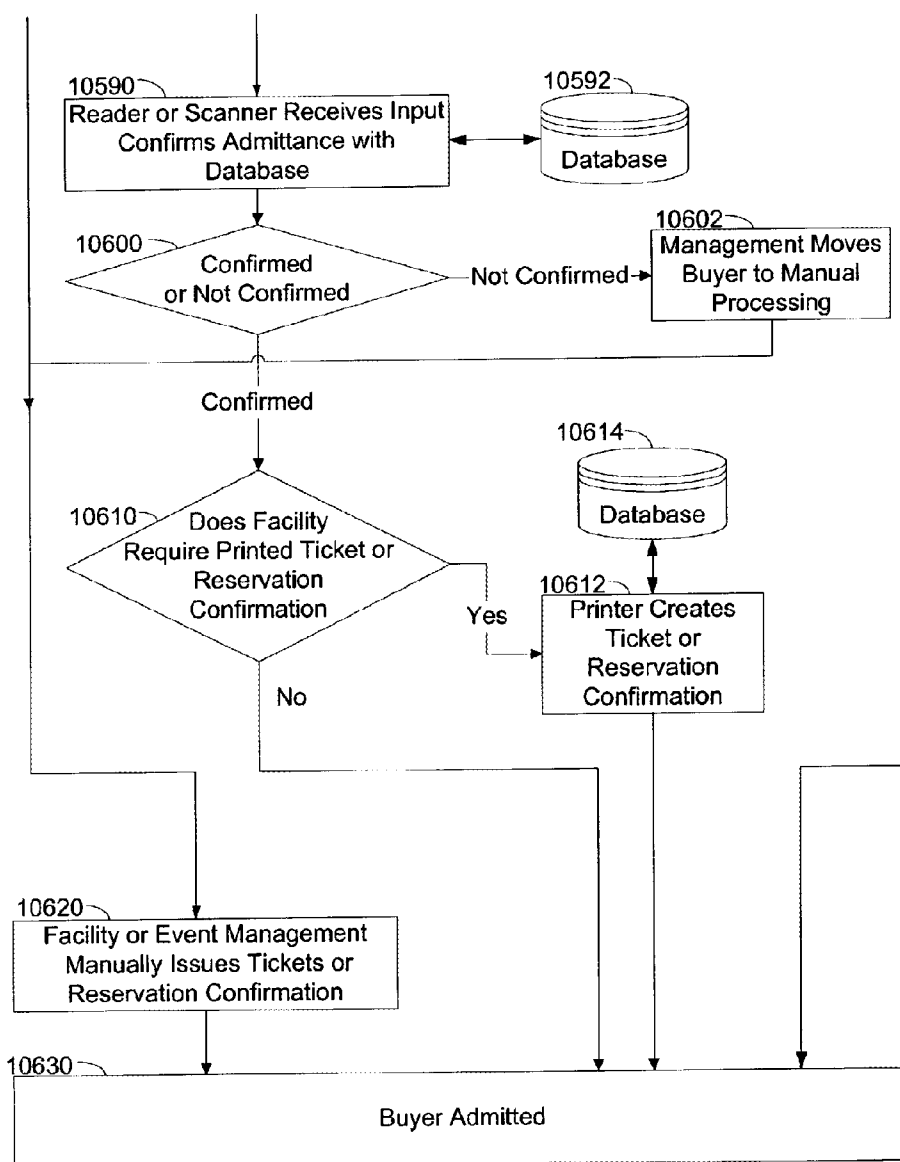


Fig. 4a

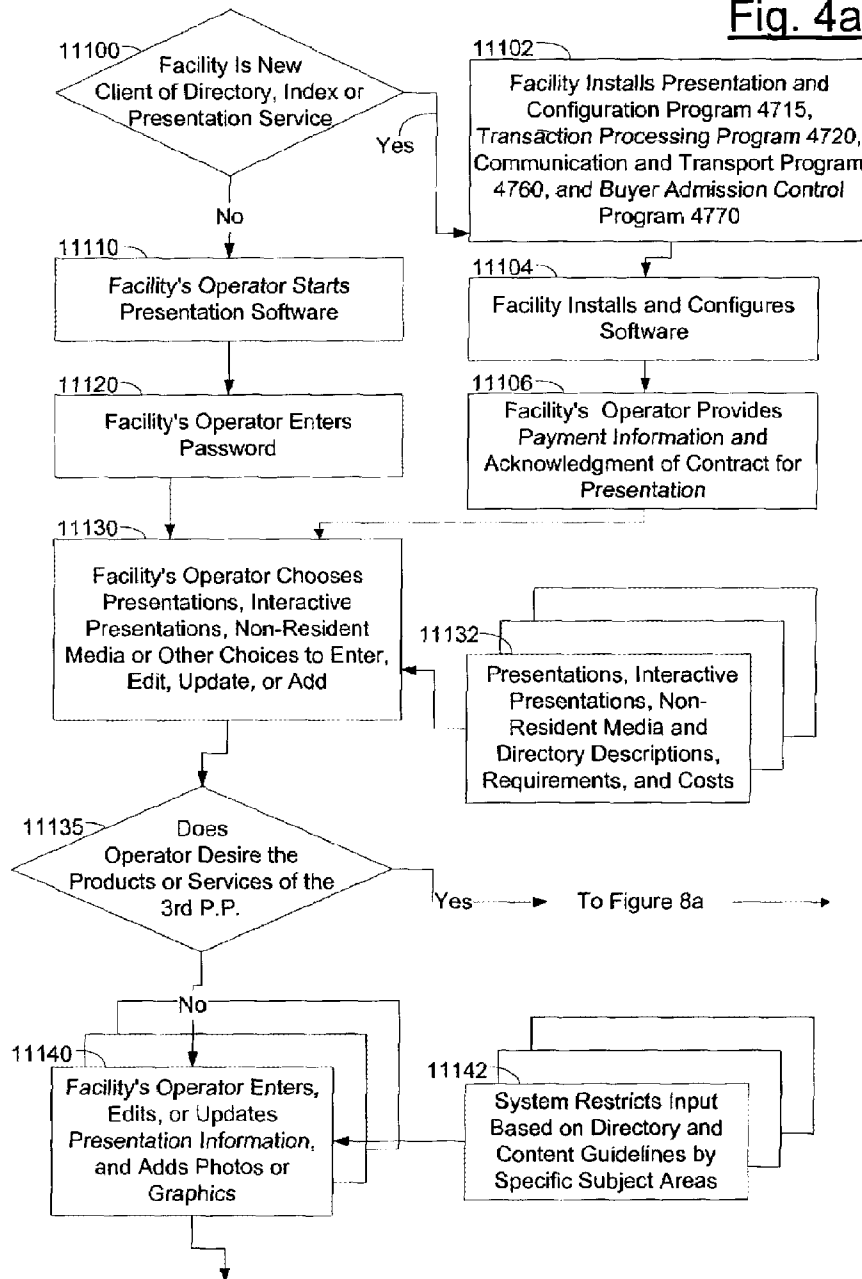




Fig. 4b

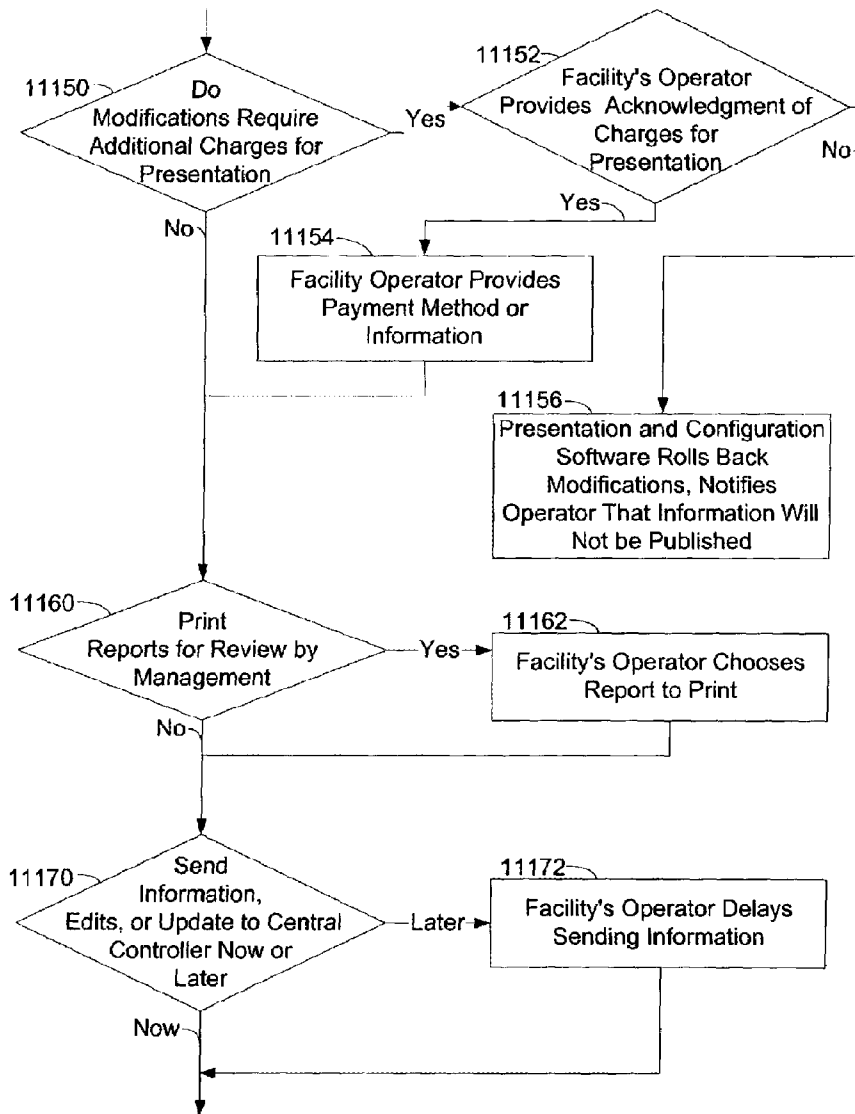
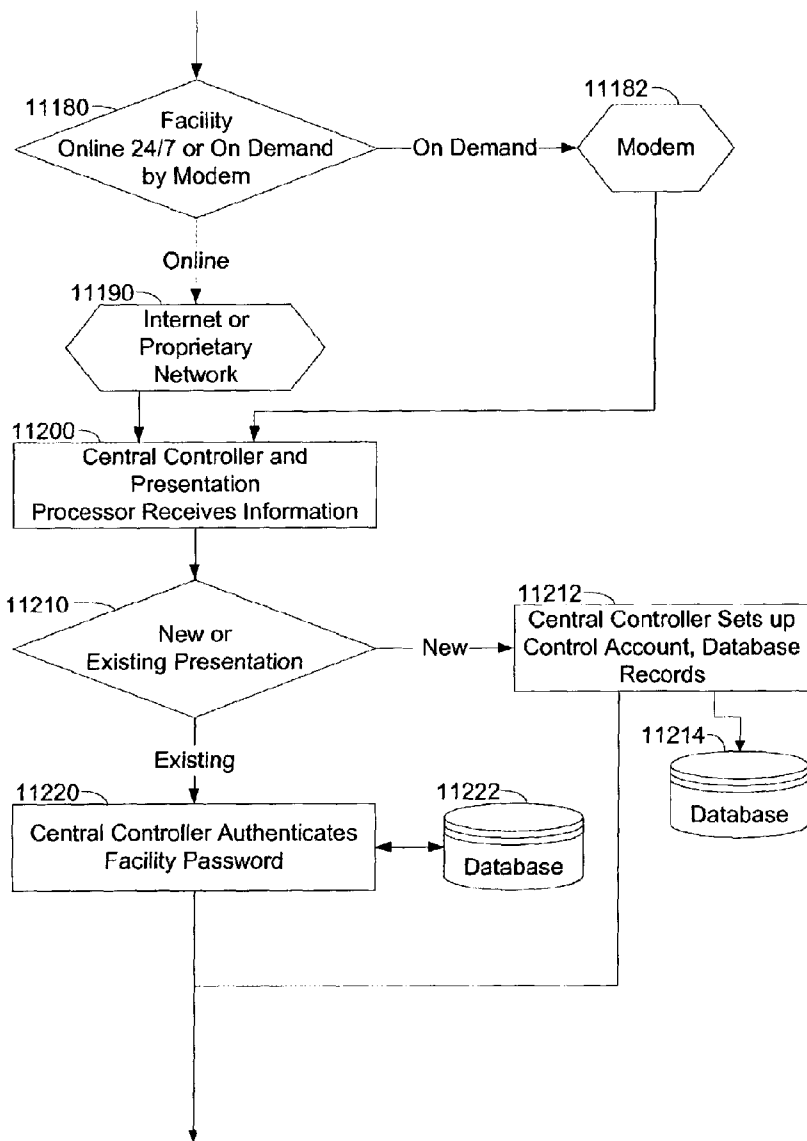


Fig. 4c



**Fig. 4d**

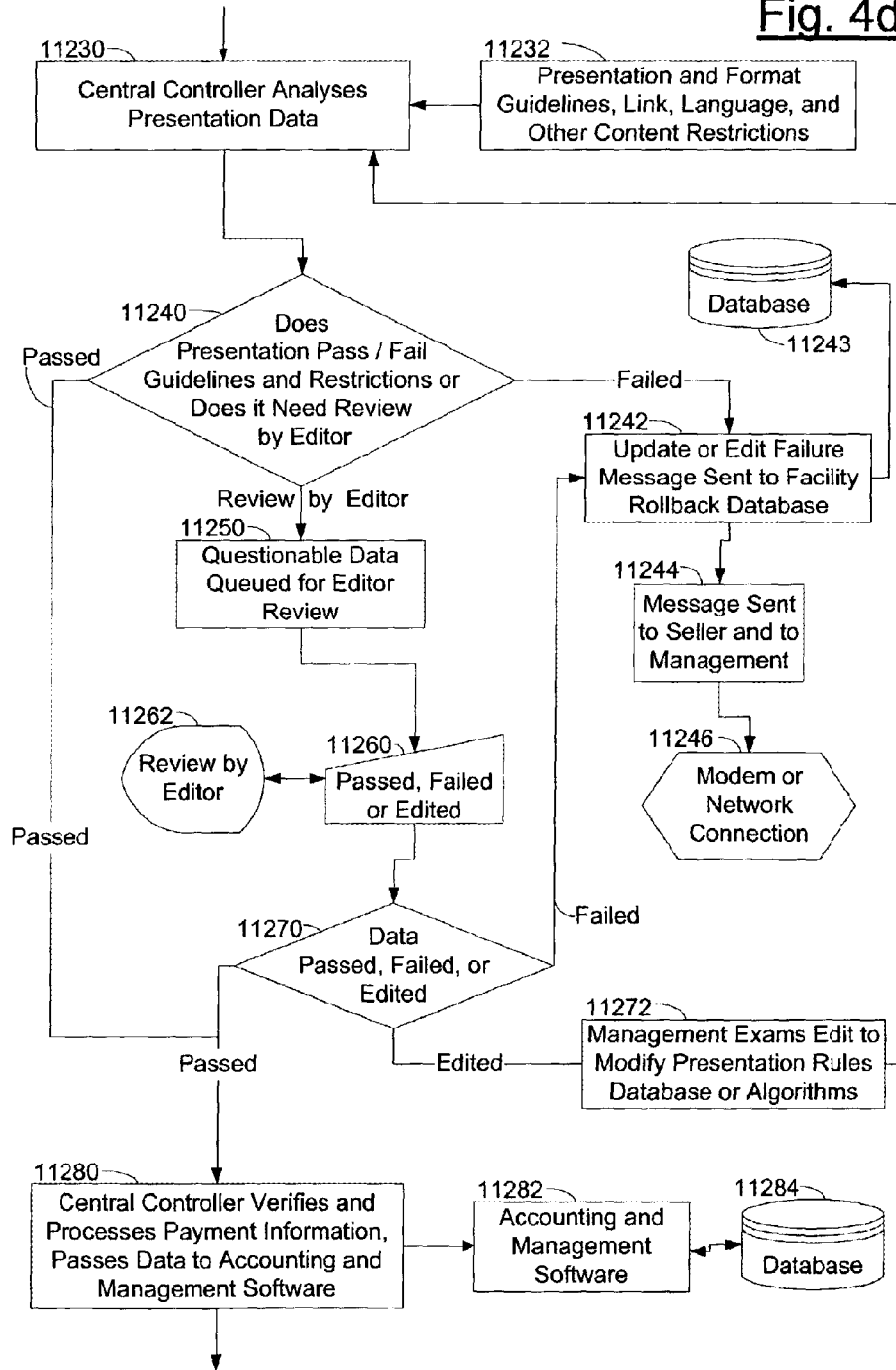
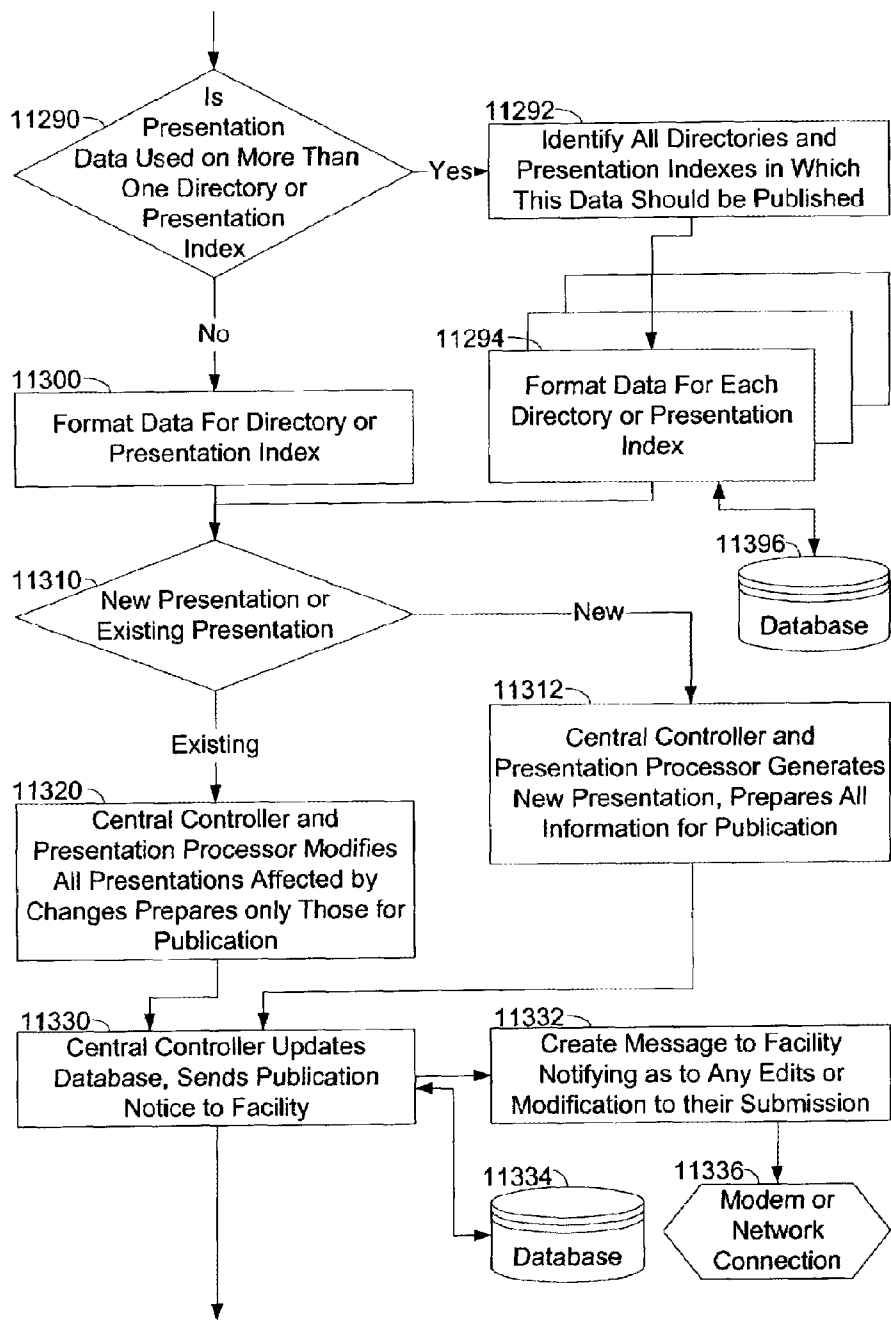


Fig. 4e



**Fig. 4f**

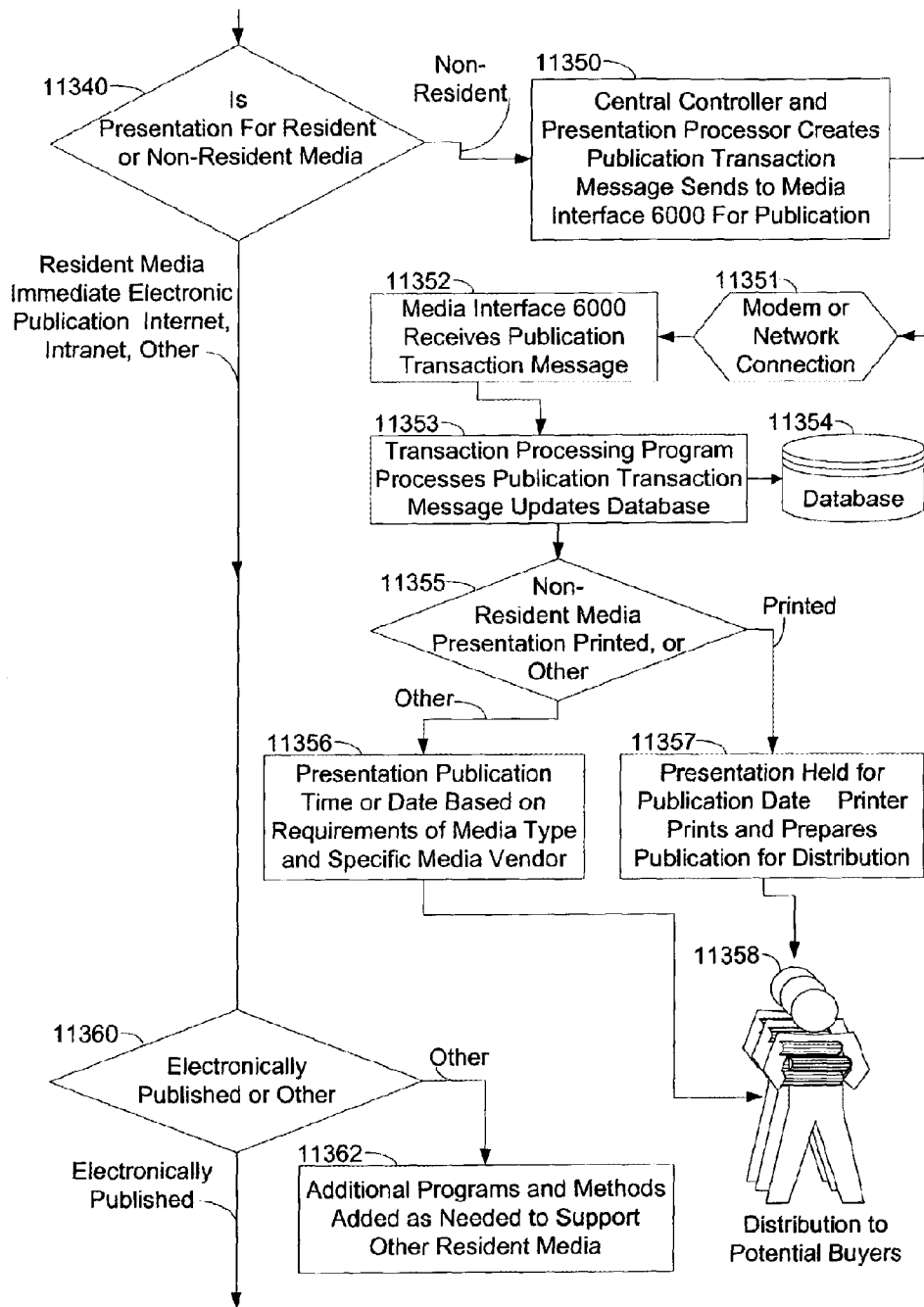


Fig. 4g

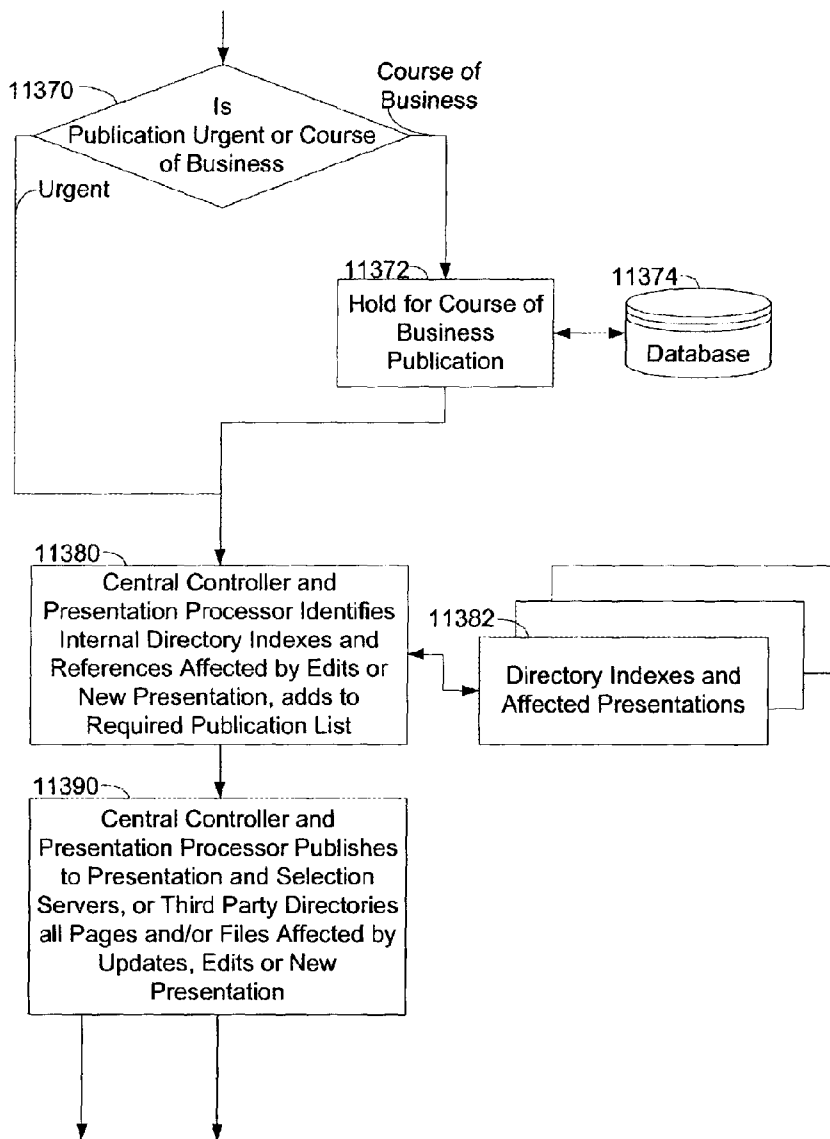


Fig. 4h

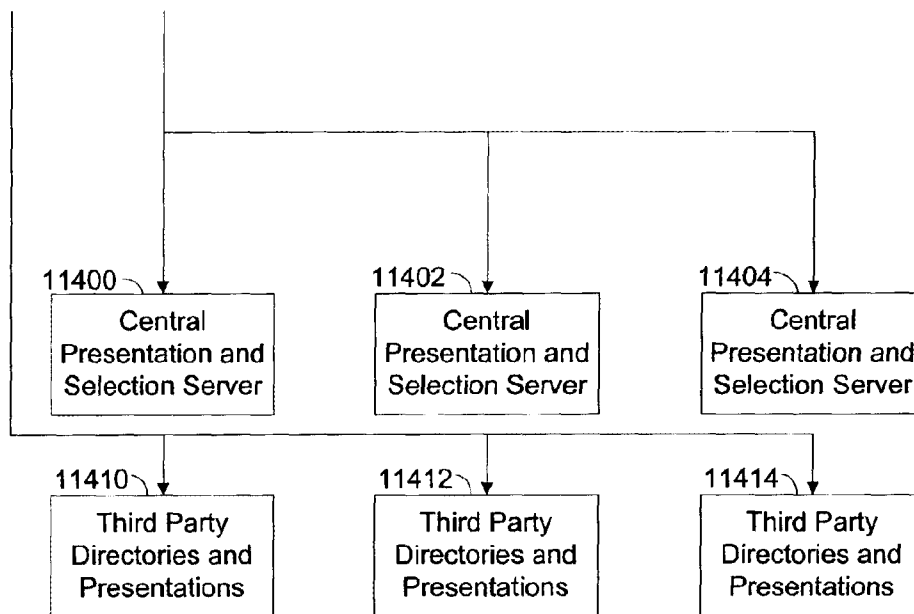


Fig. 5a

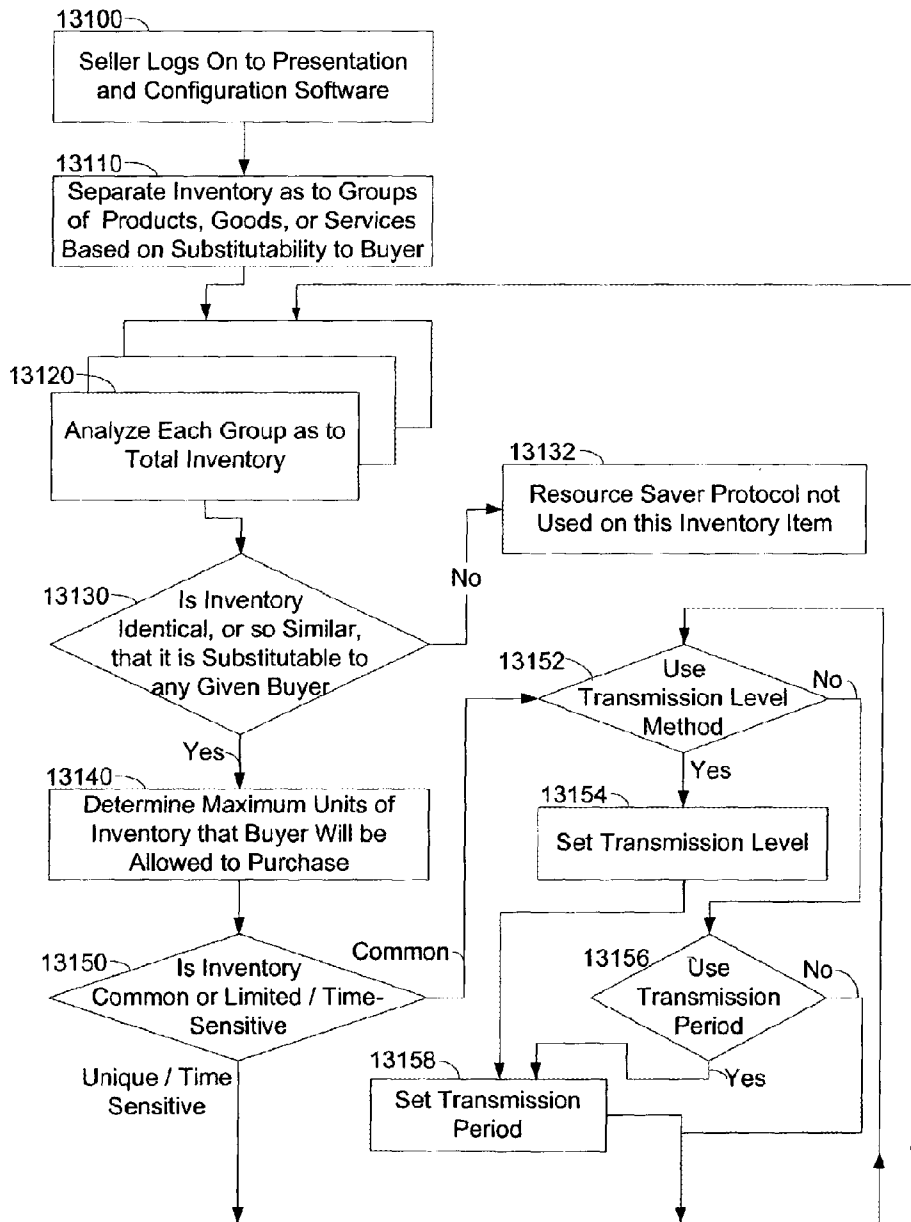




Fig. 5b

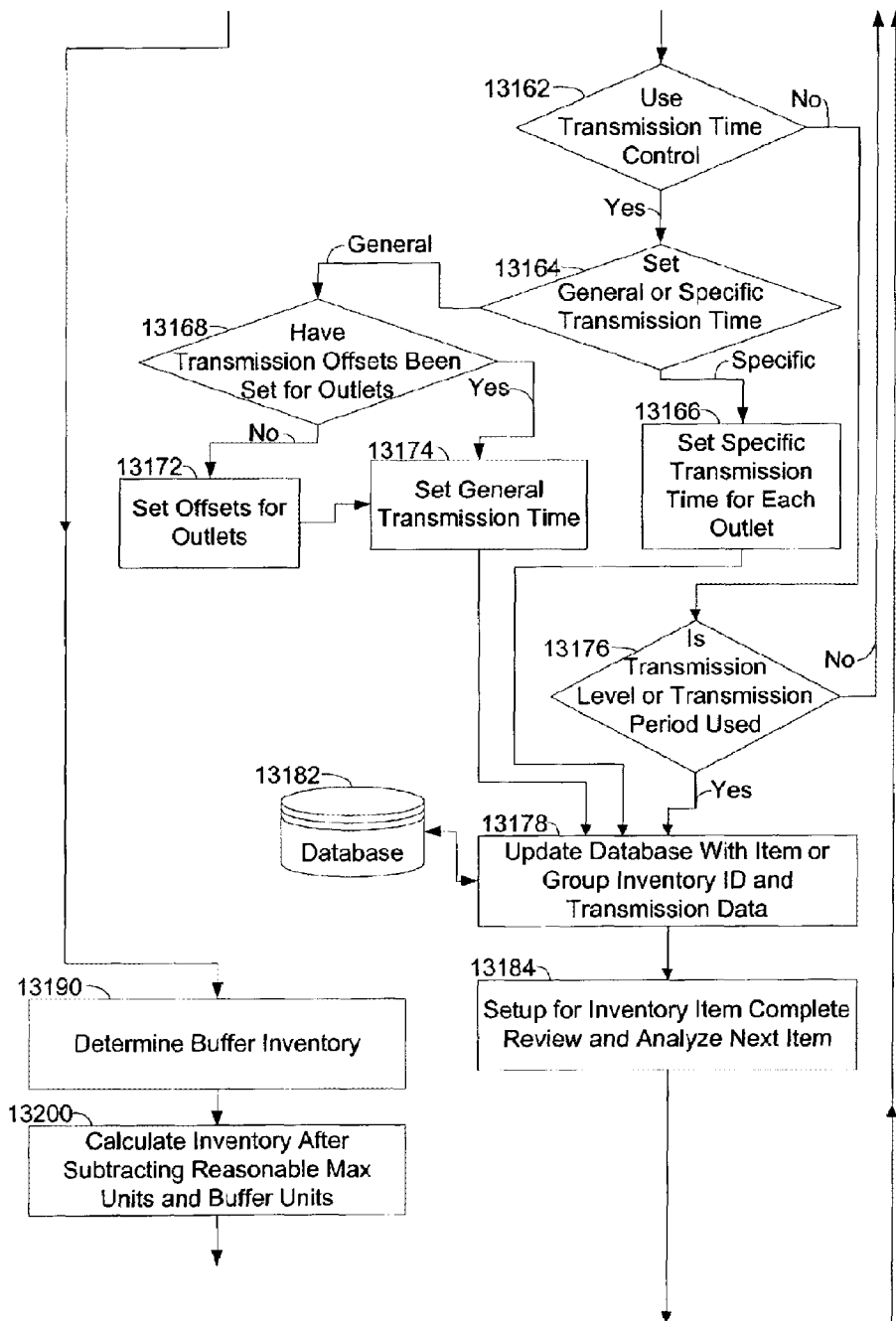


Fig. 5c

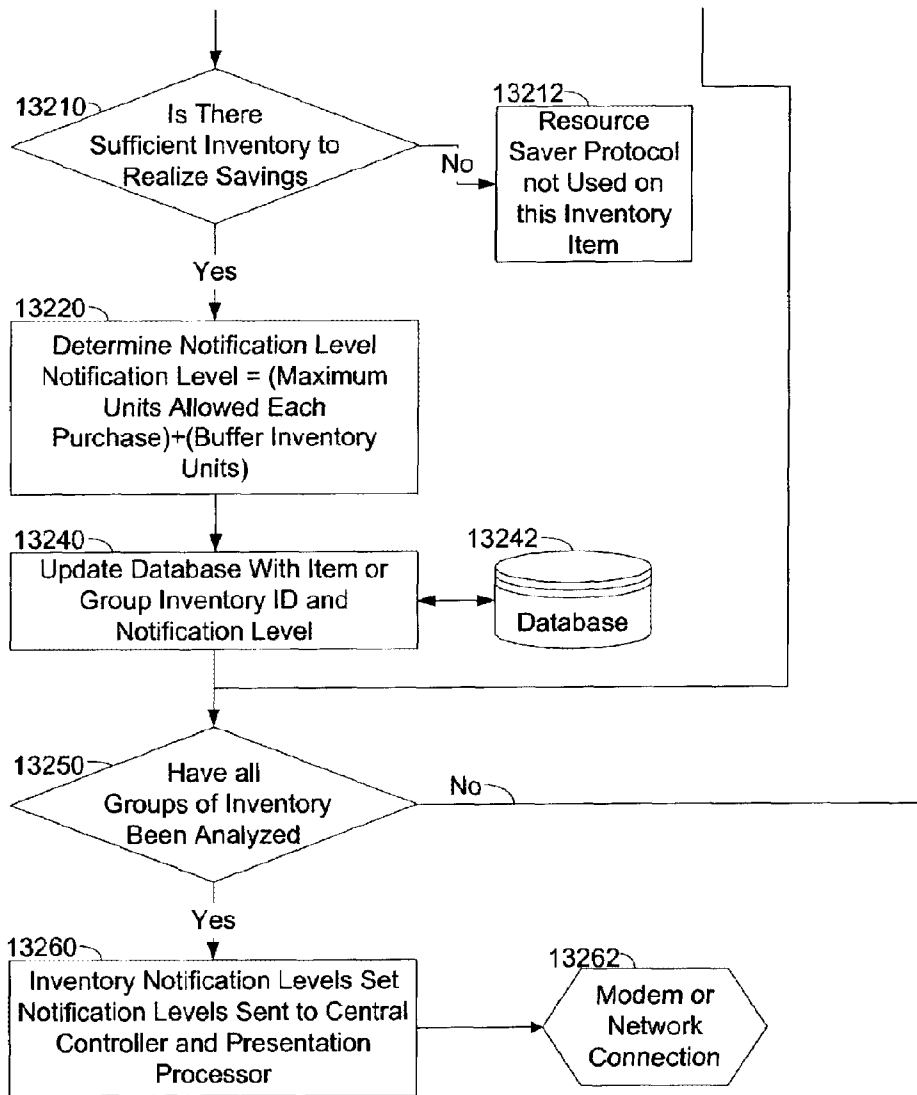


Fig. 5d

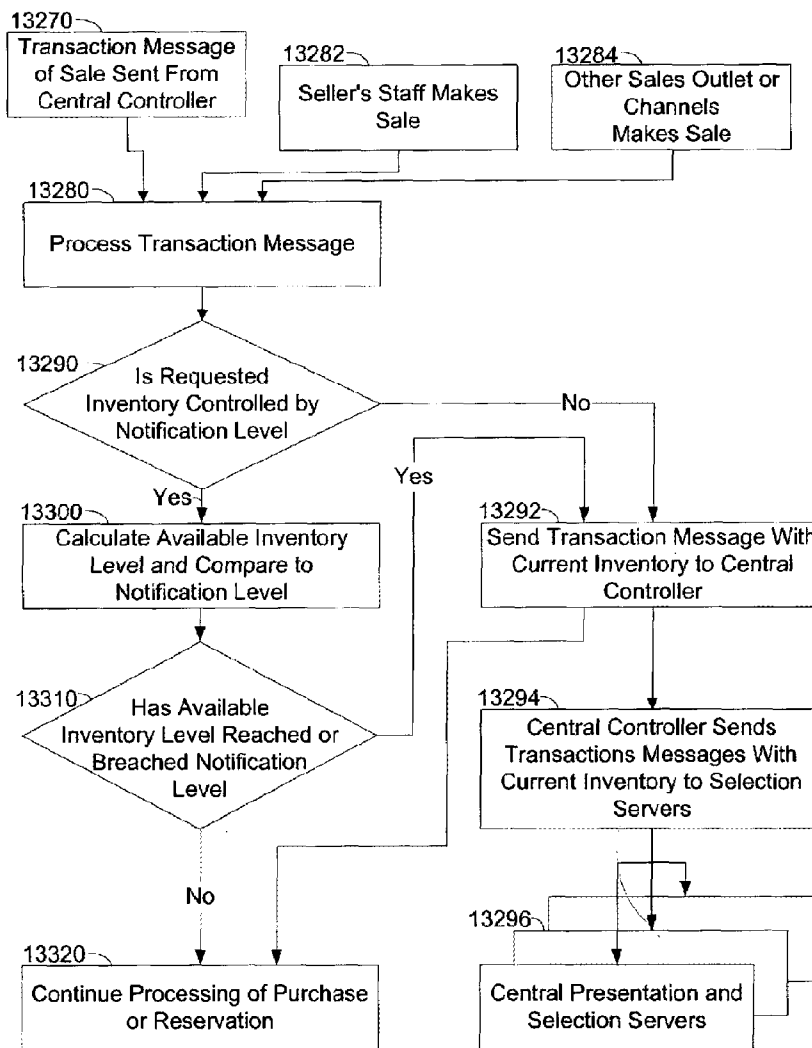
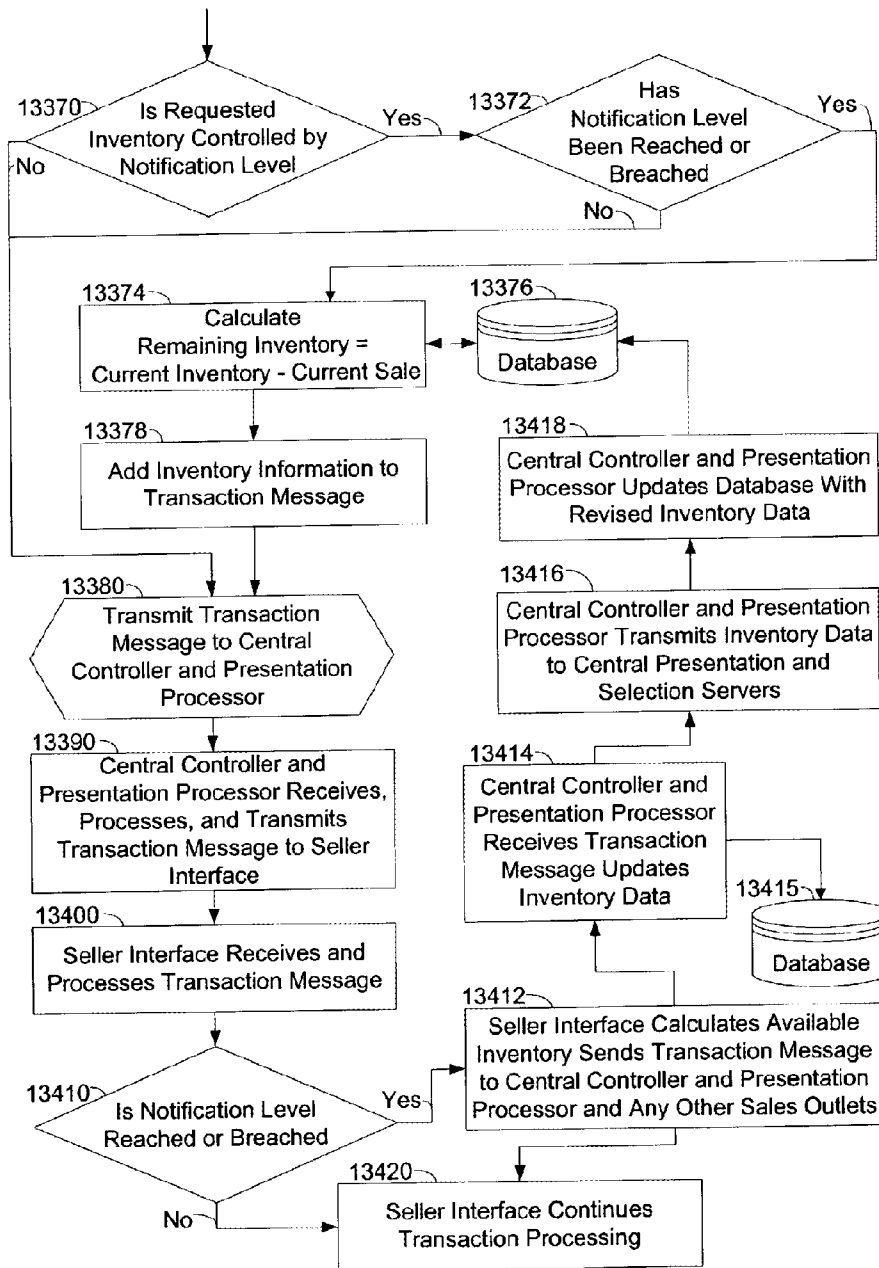


Fig. 5f



**Fig. 5e**

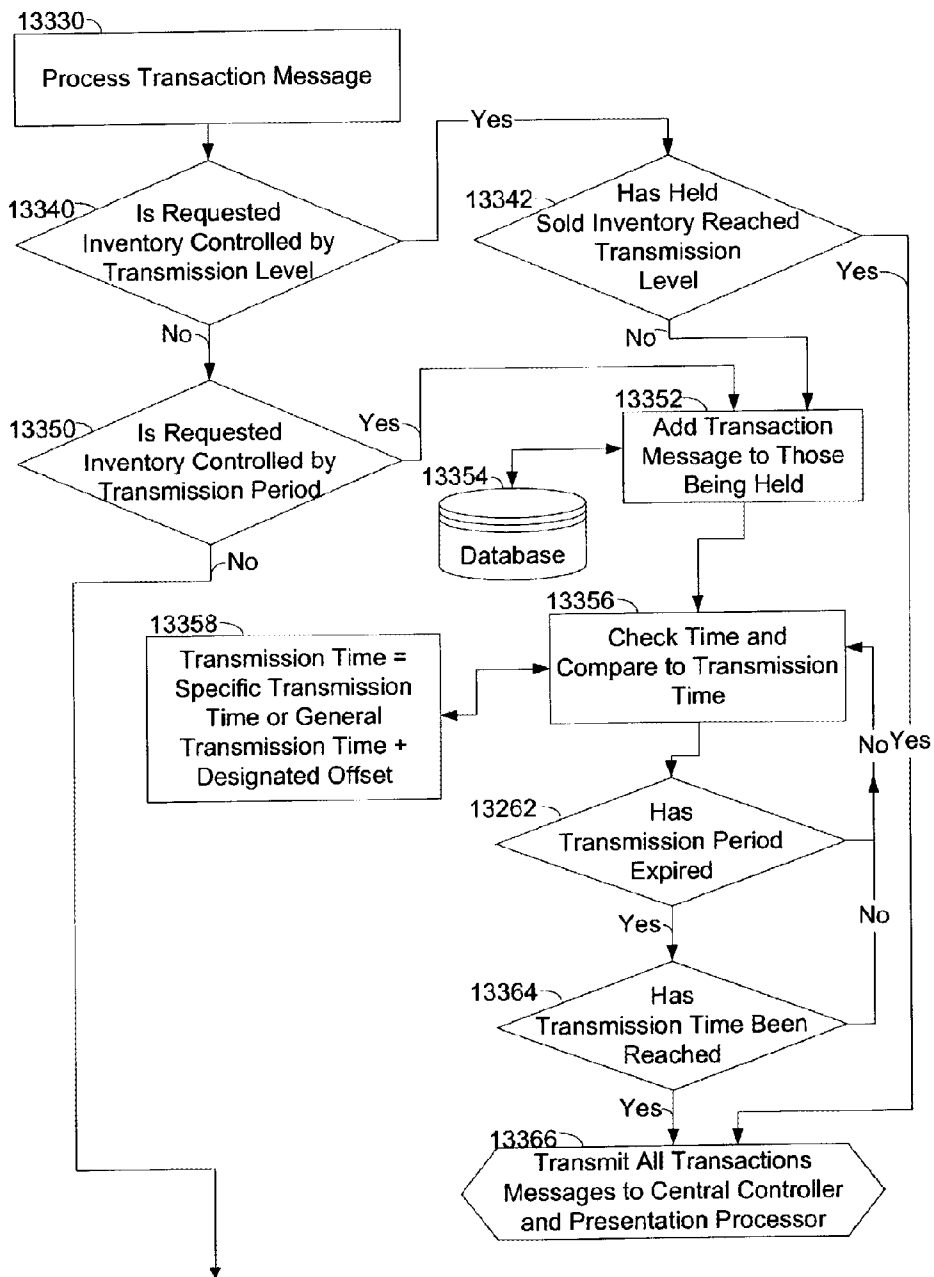


Fig. 5g

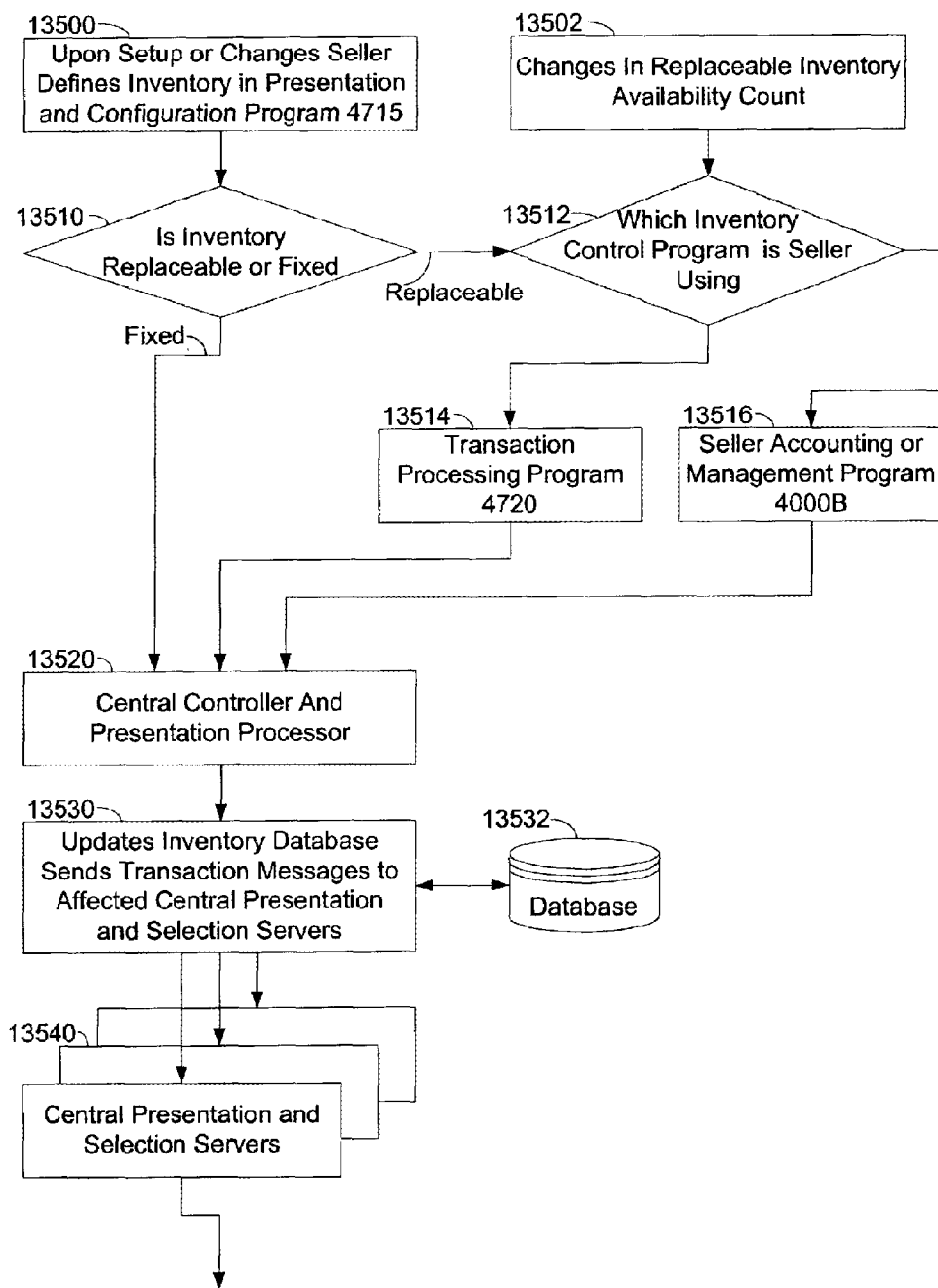
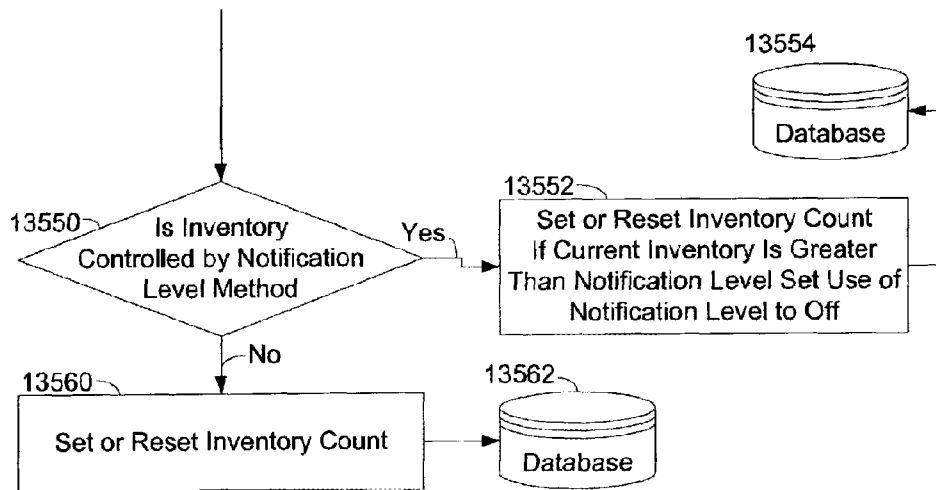
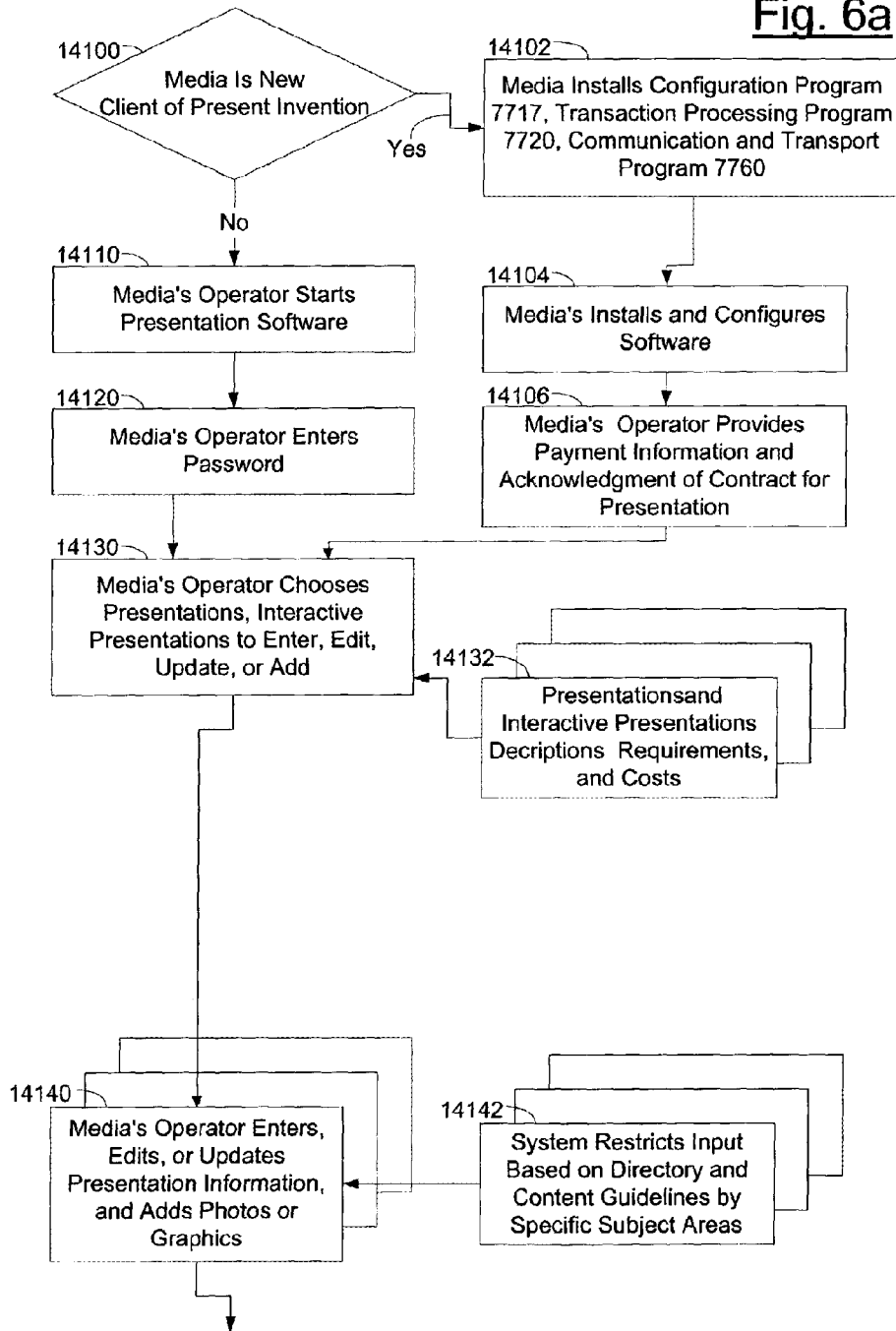


Fig. 5h



**Fig. 6a**





**Fig. 6b**

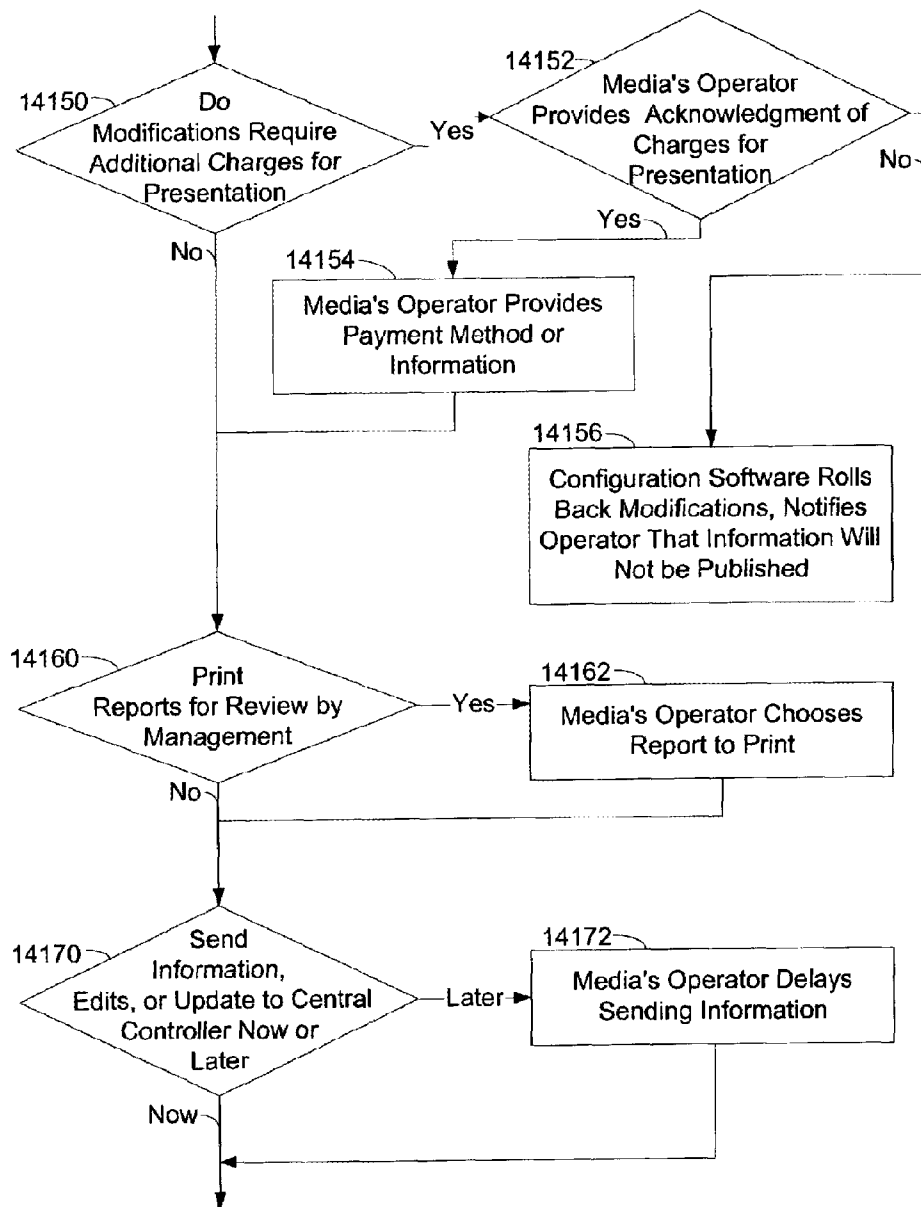
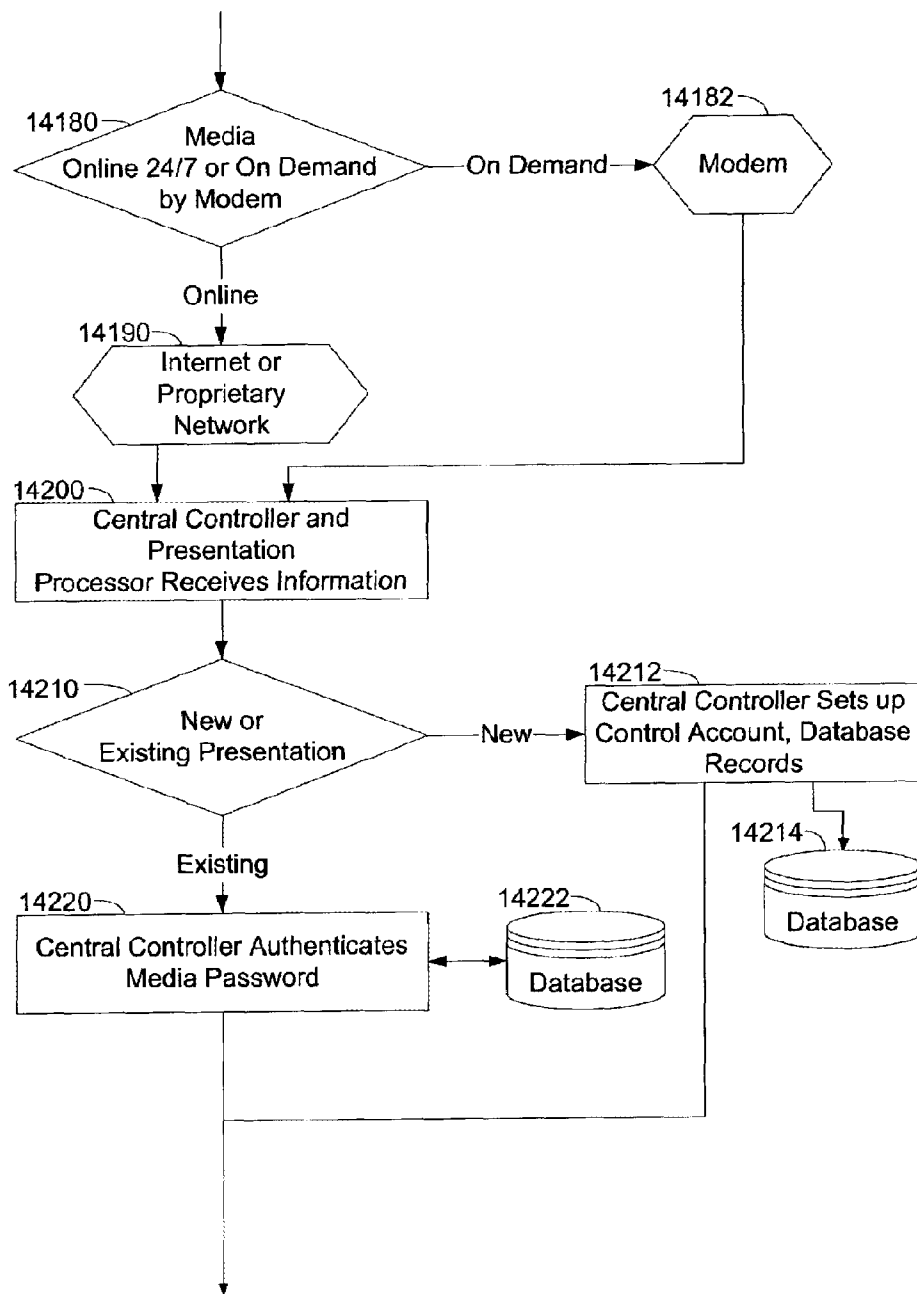
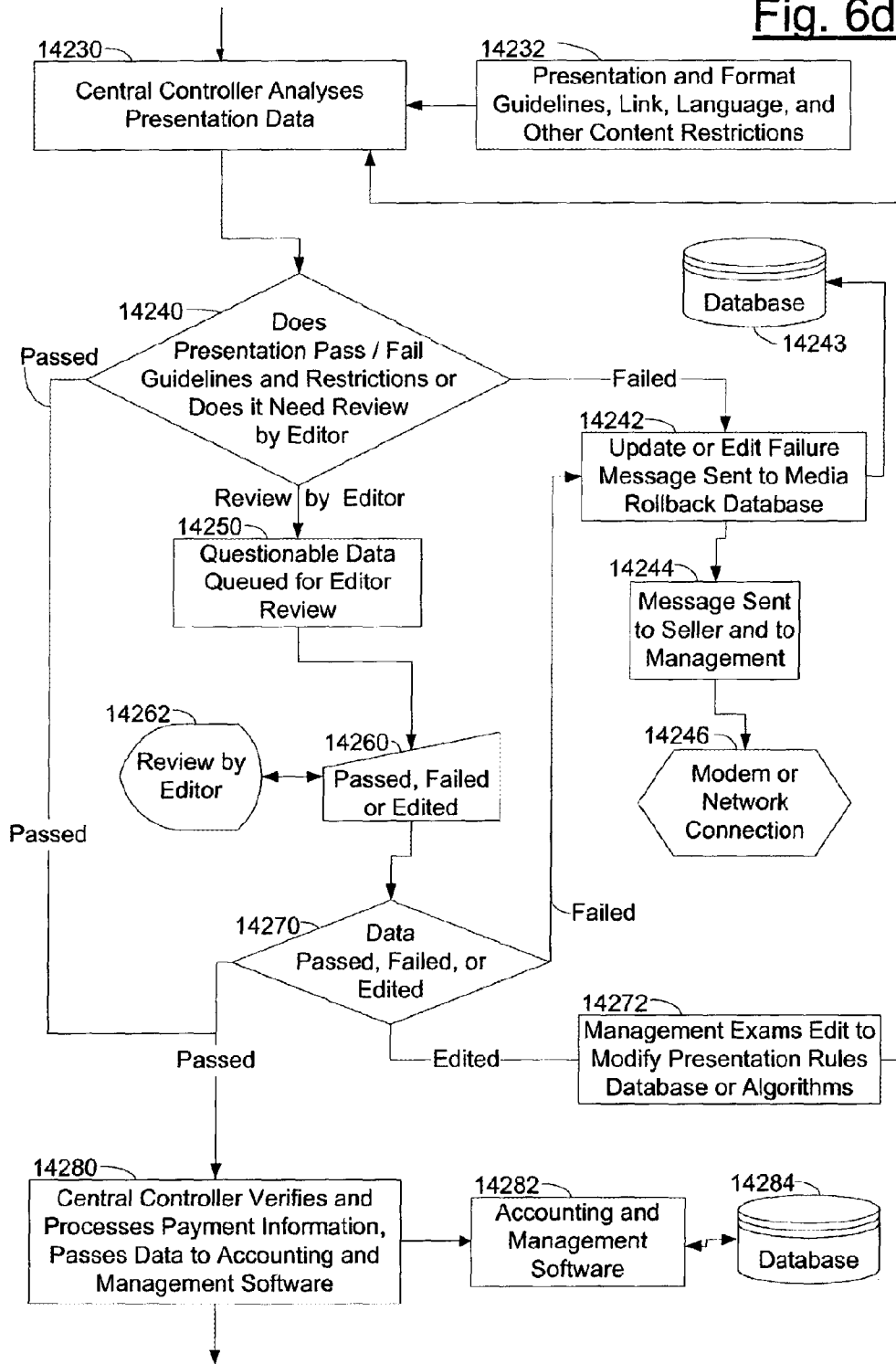


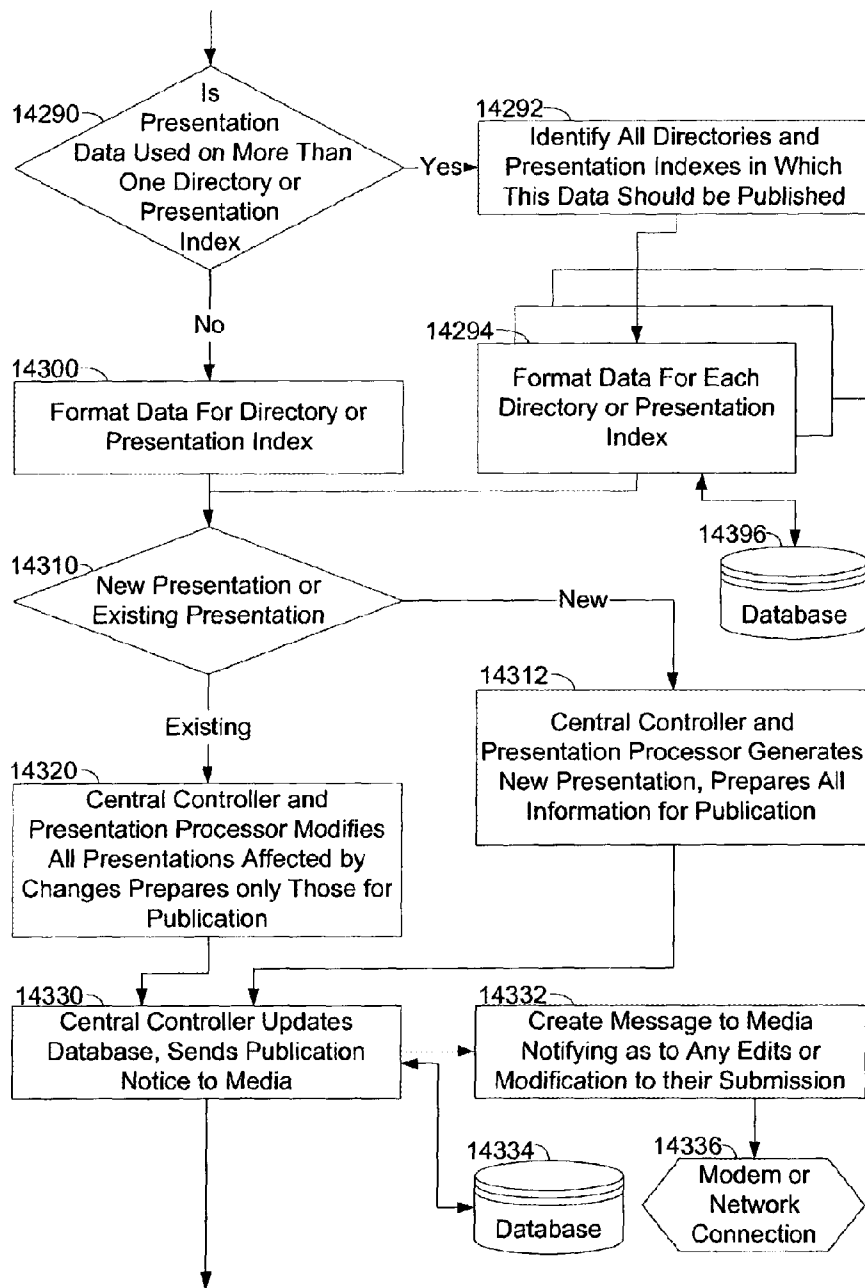
Fig. 6c



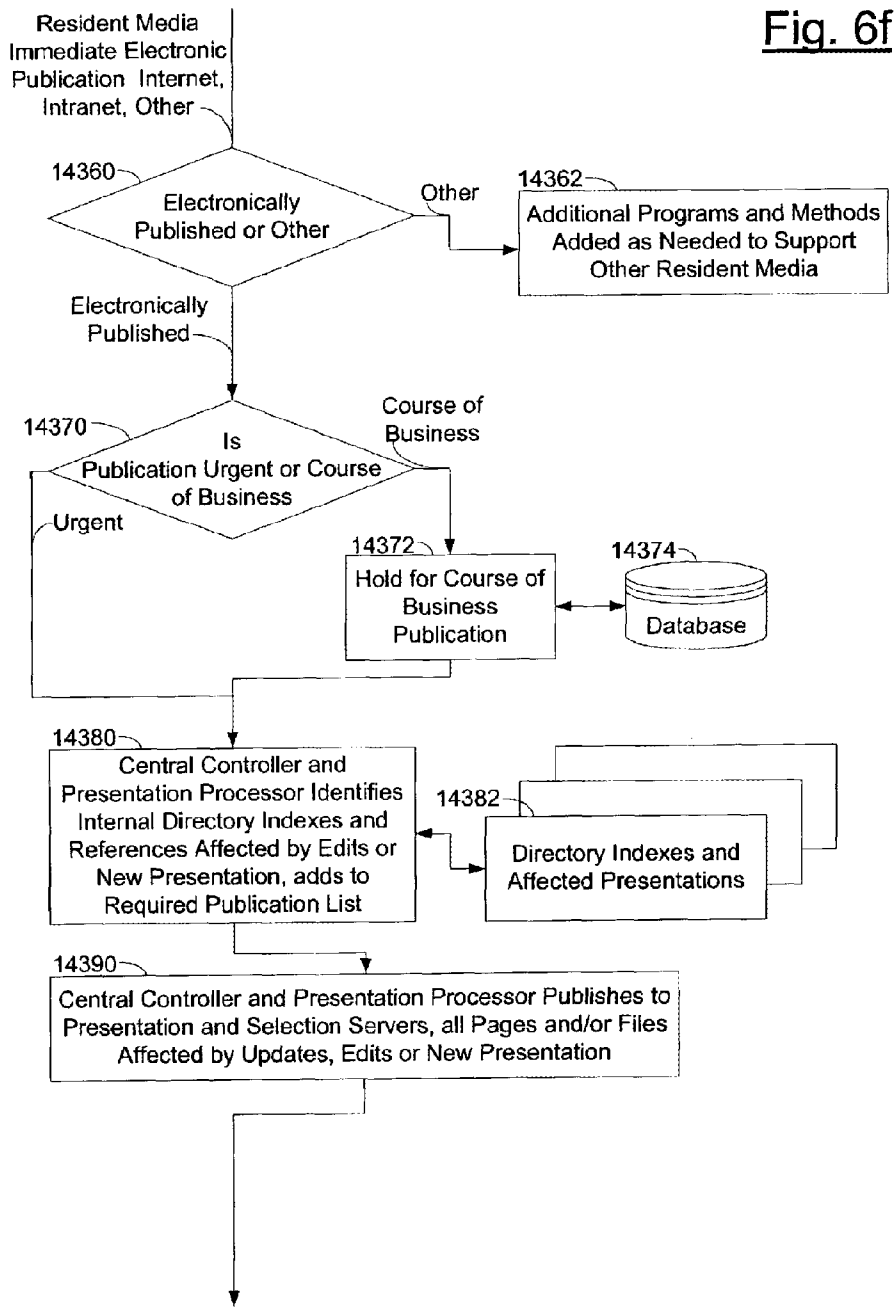
**Fig. 6d**



**Fig. 6e**



**Fig. 6f**



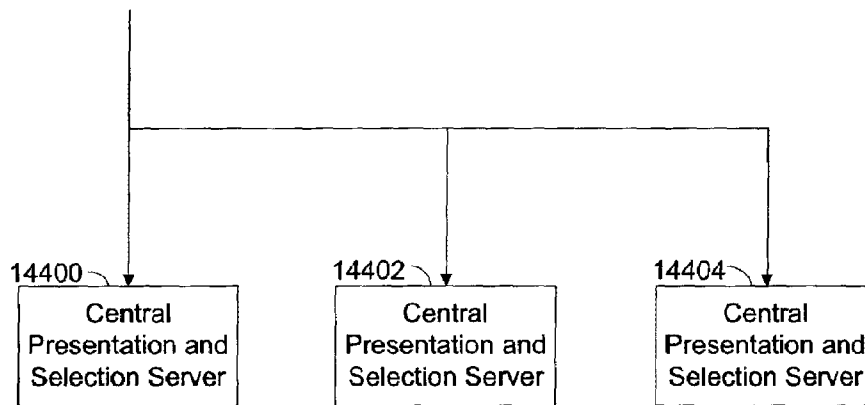
U.S. Patent

Jul. 24, 2007

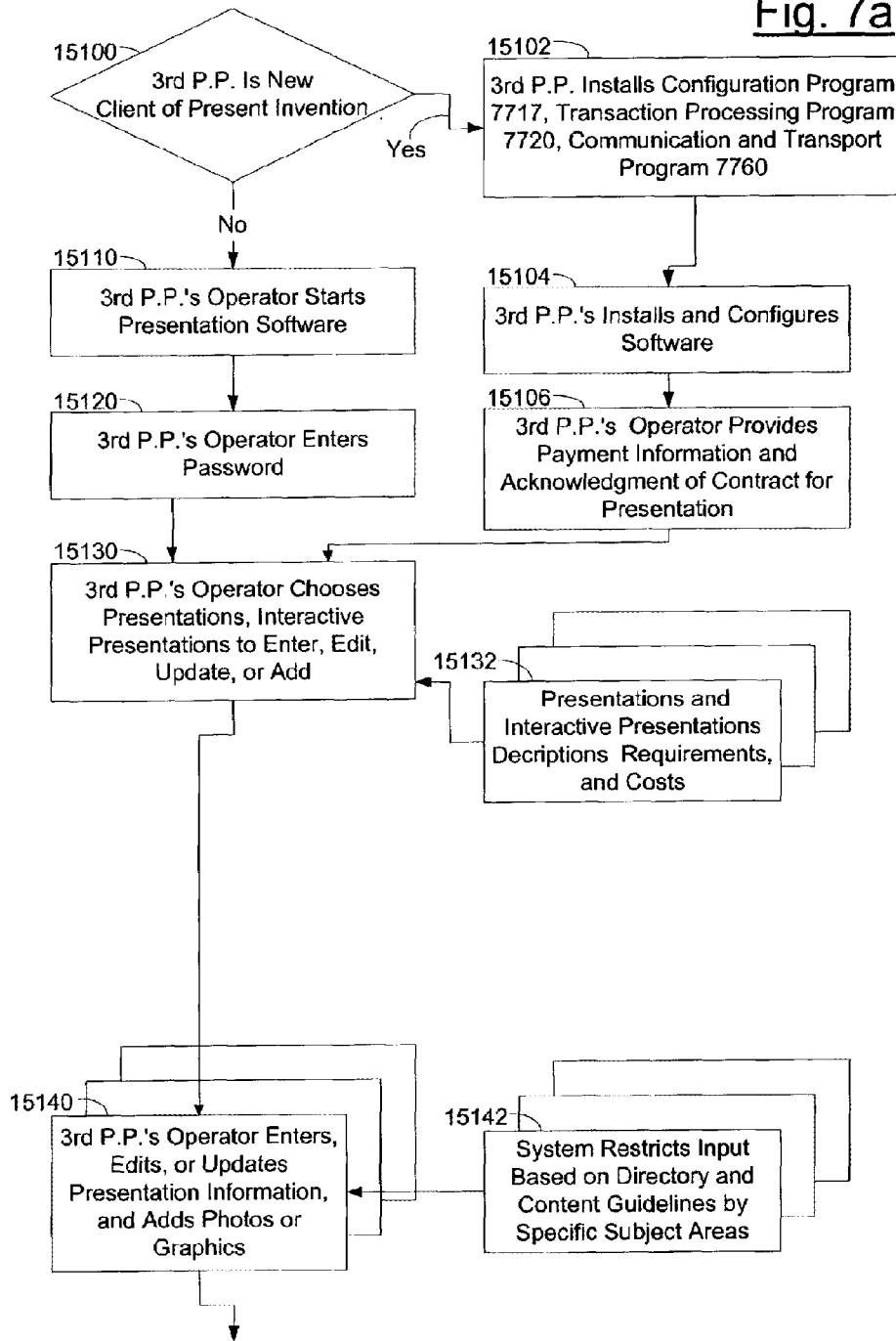
Sheet 43 of 55

US 7,249,059 B2

Fig. 6g



**Fig. 7a**



**Fig. 7b**

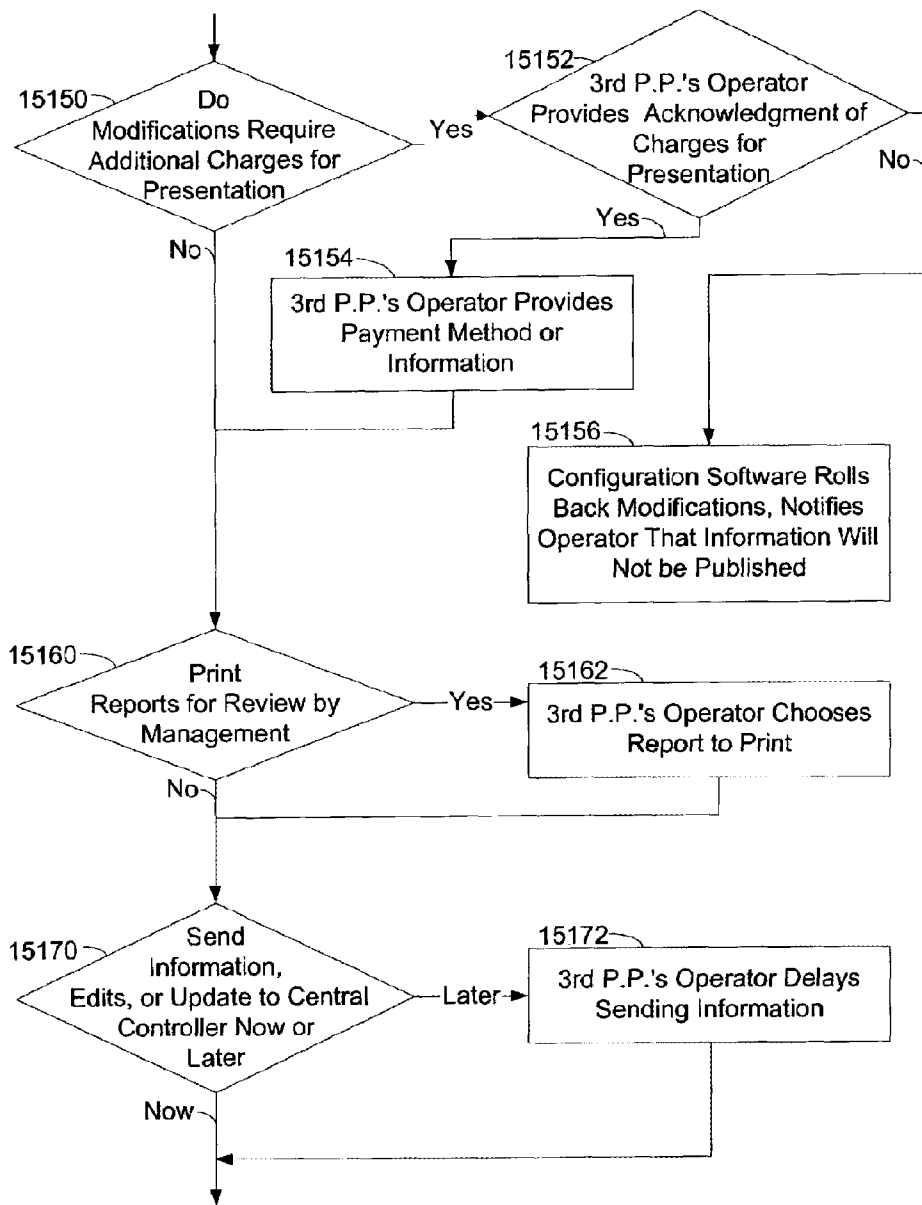




Fig. 7c

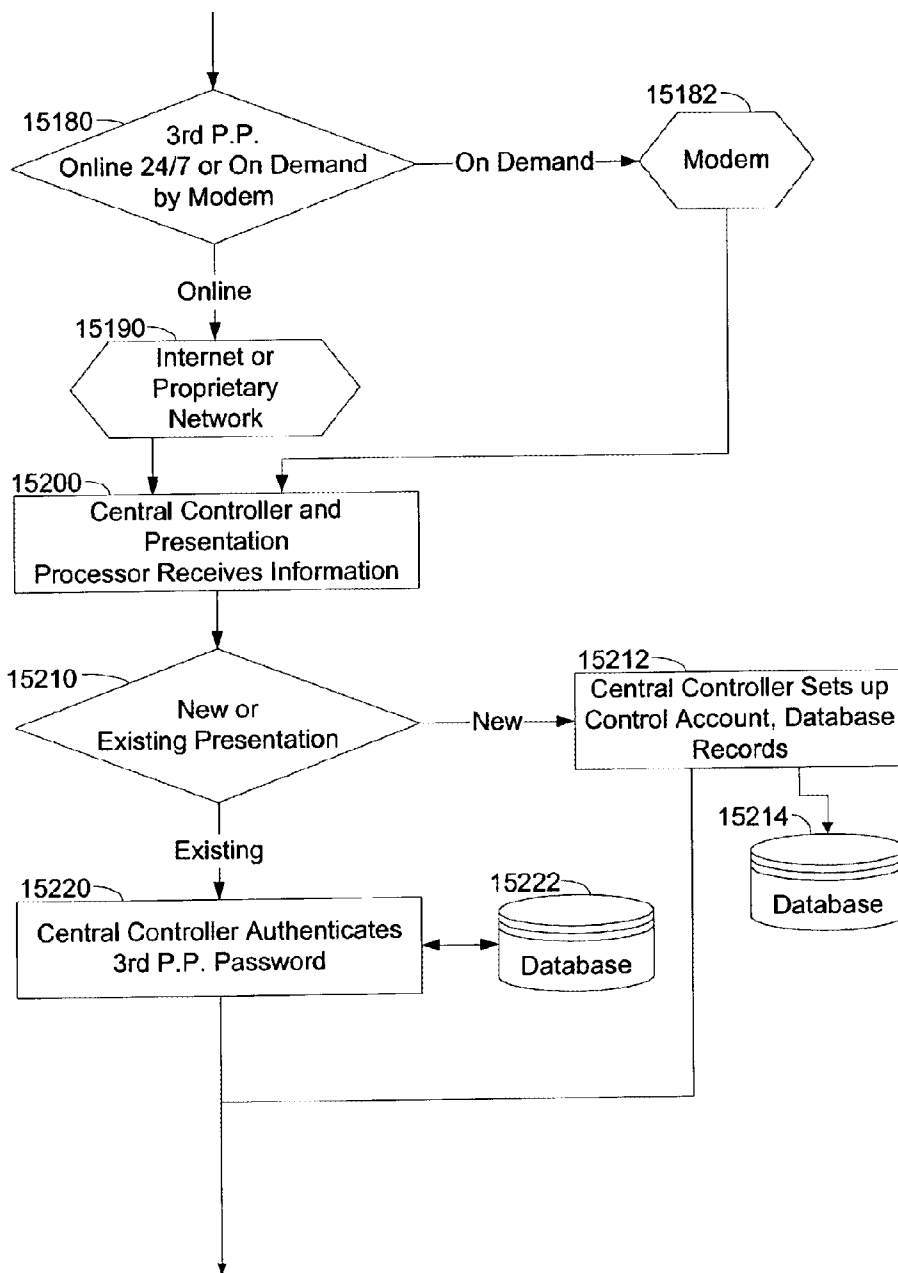


Fig. 7d

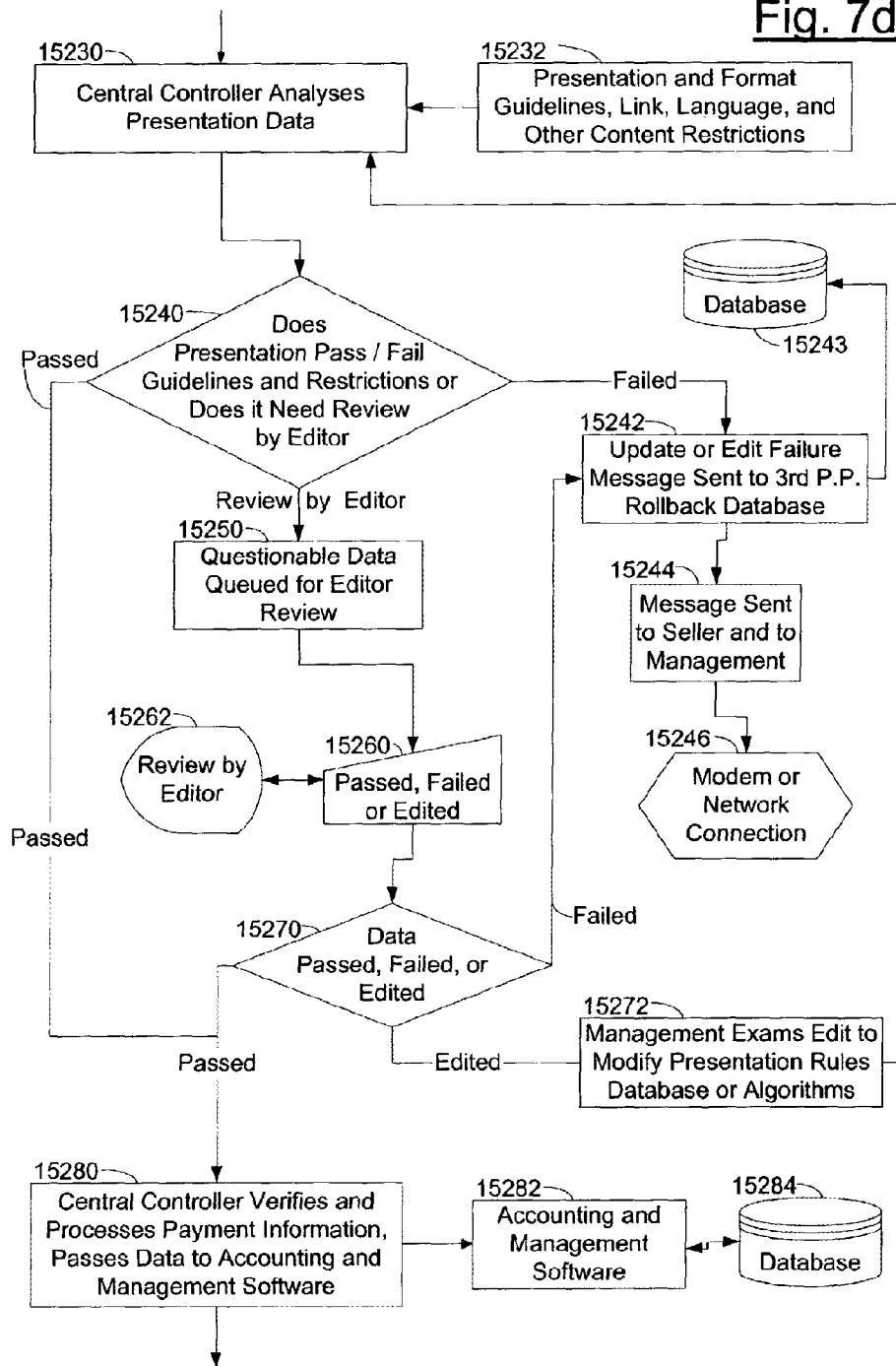
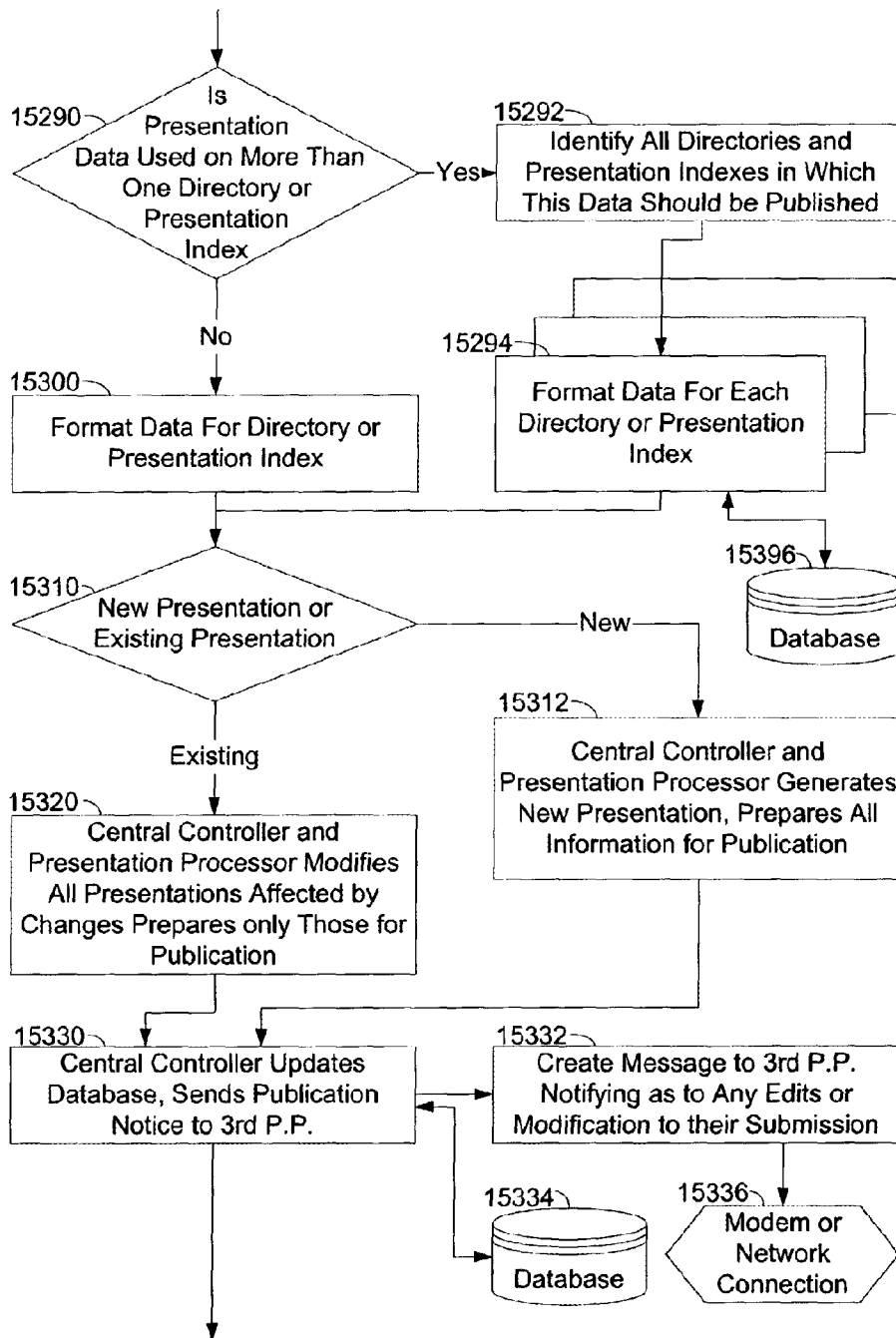


Fig. 7e



**Fig. 7f**

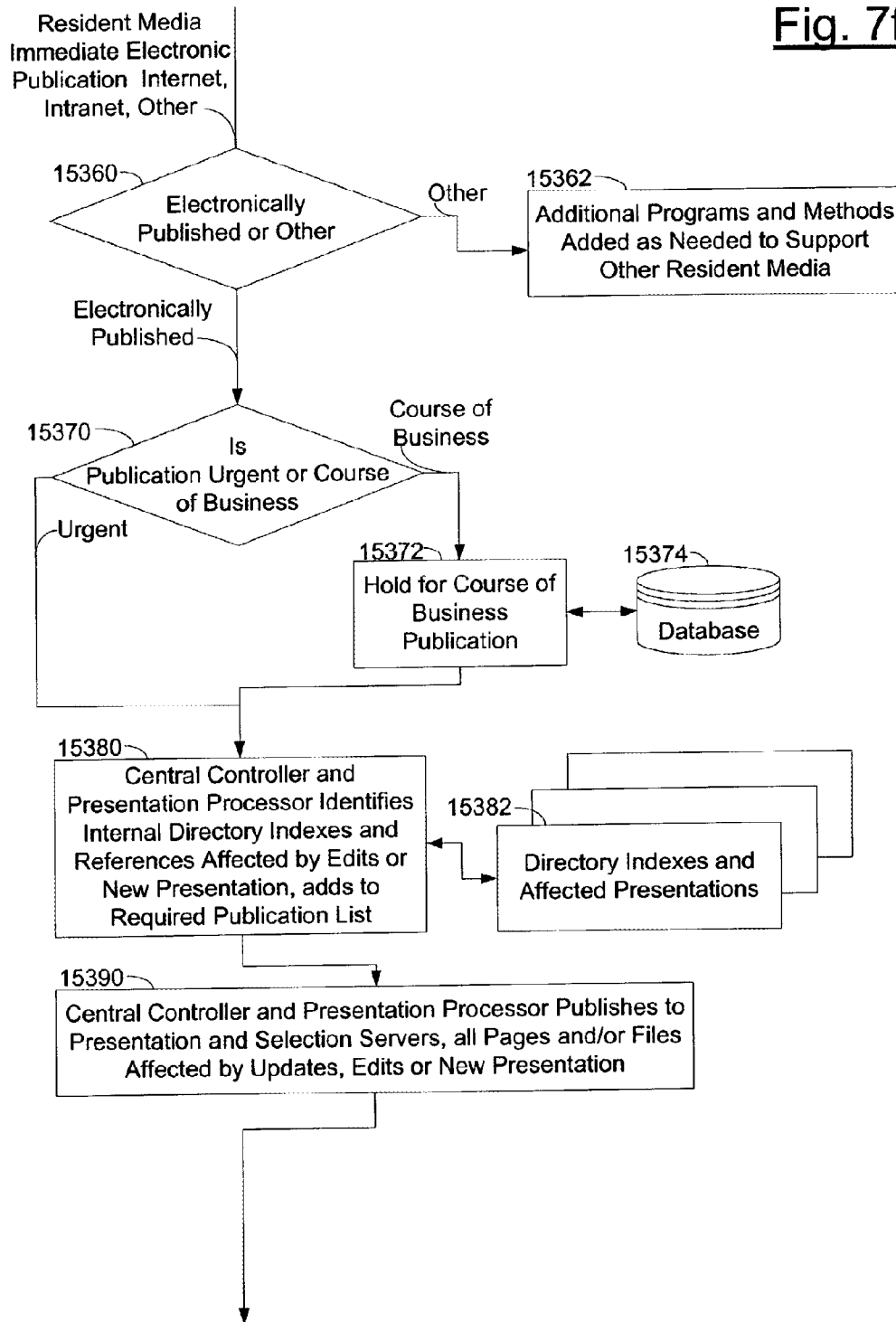
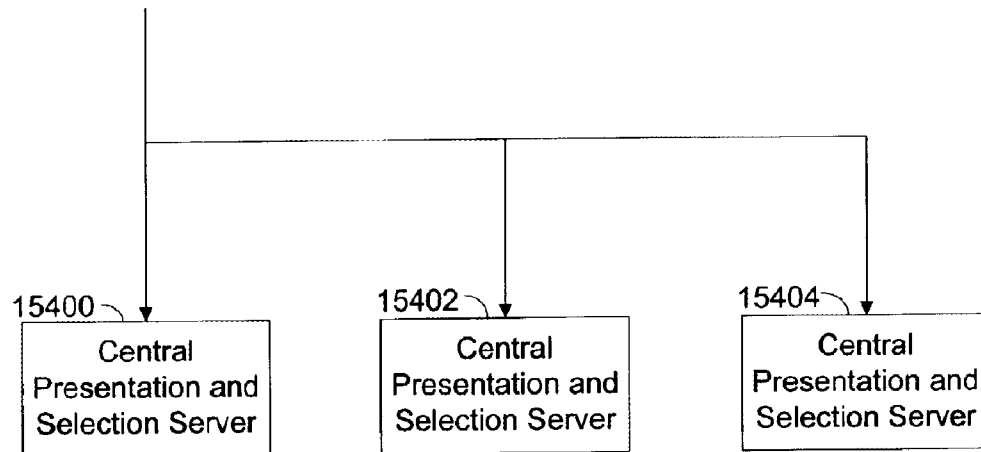
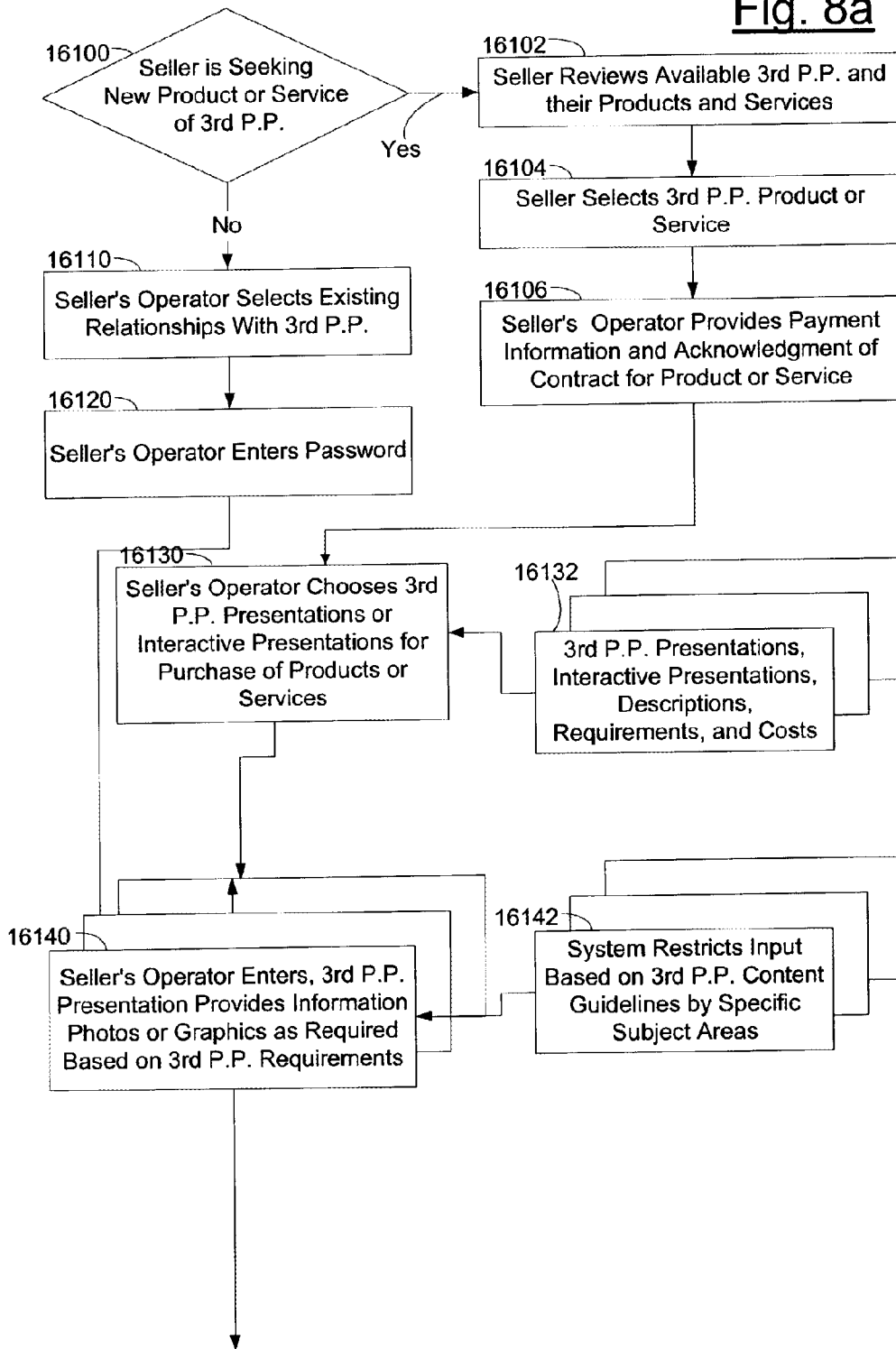


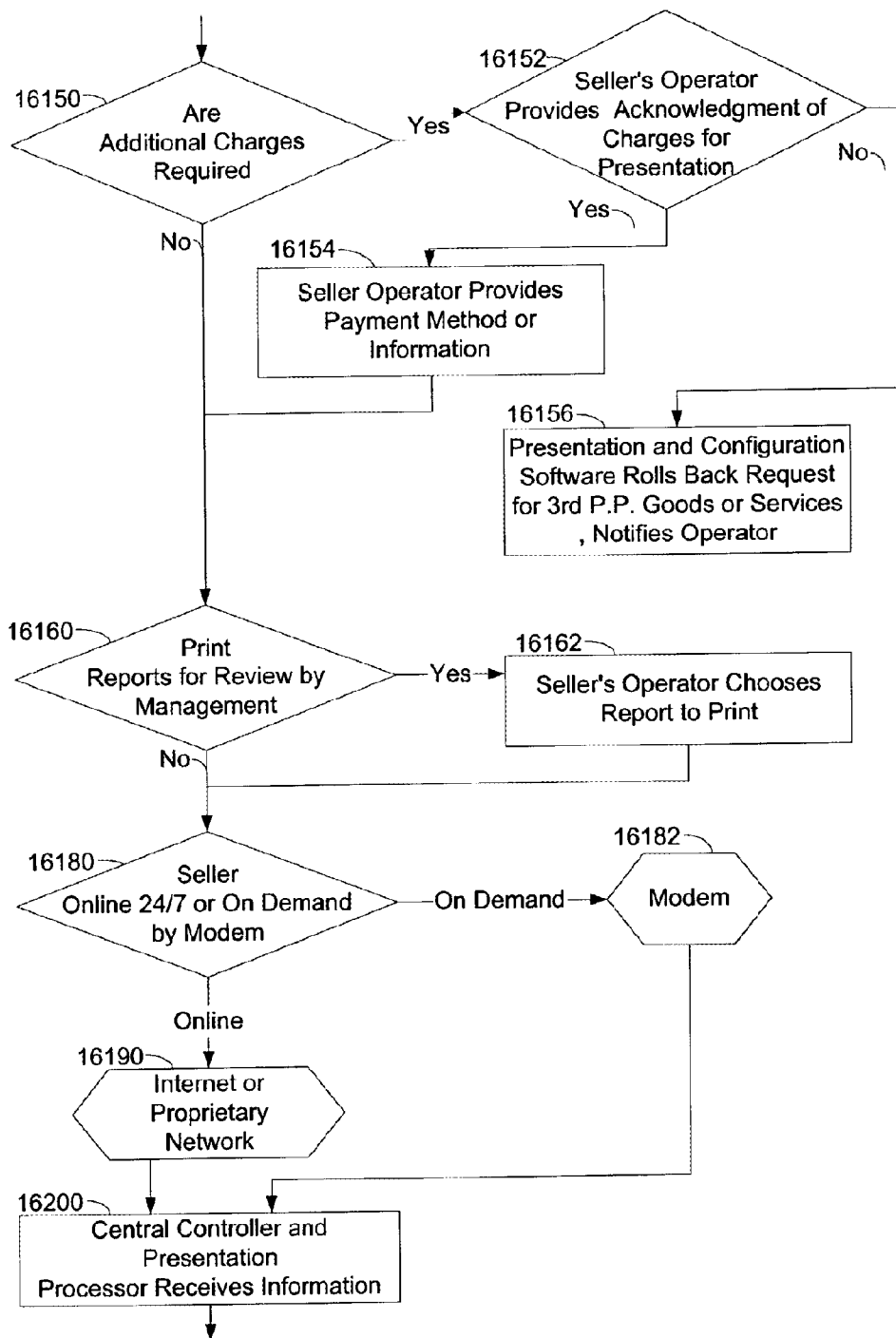
Fig. 7g



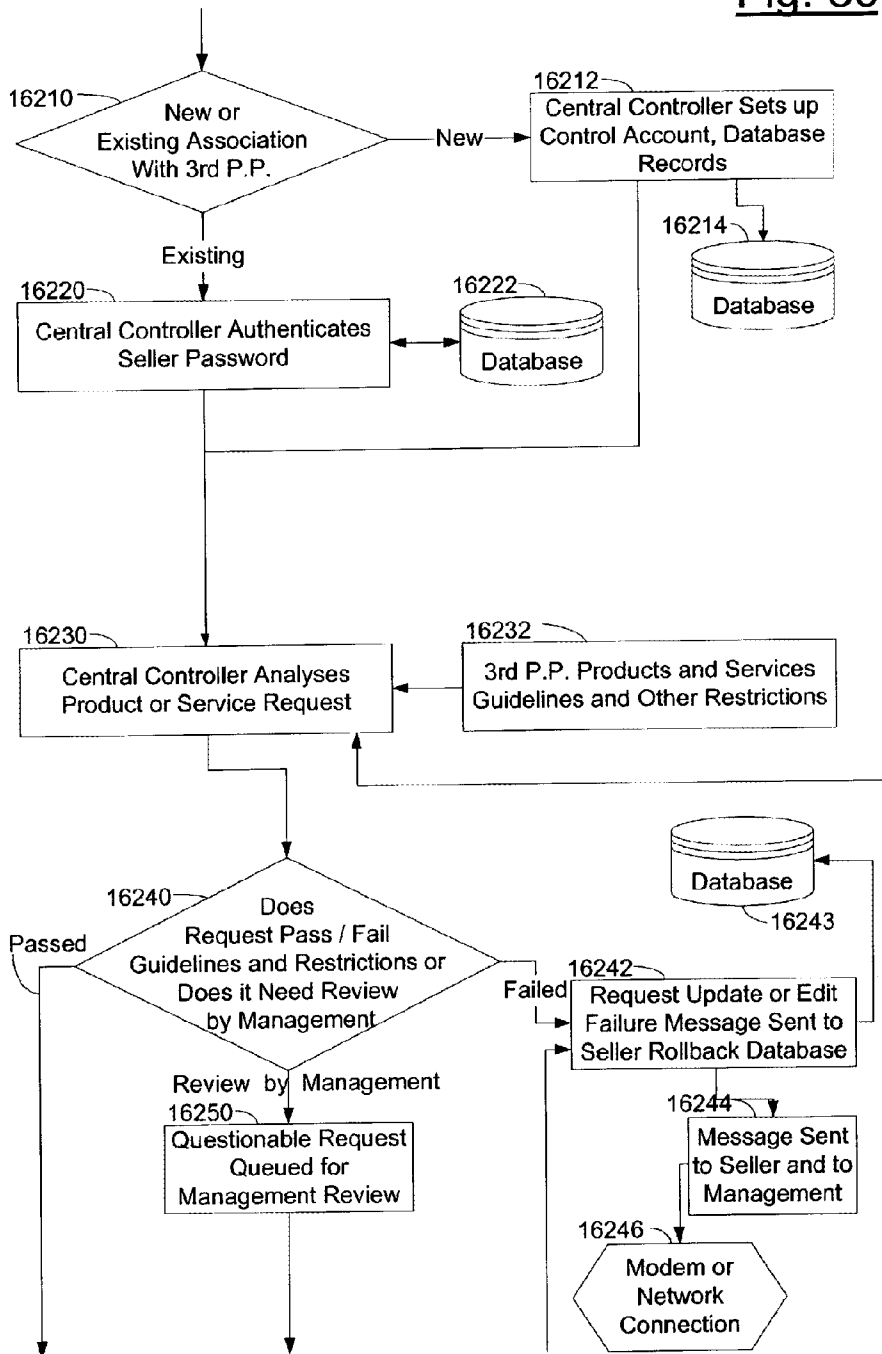
**Fig. 8a**



**Fig. 8b**

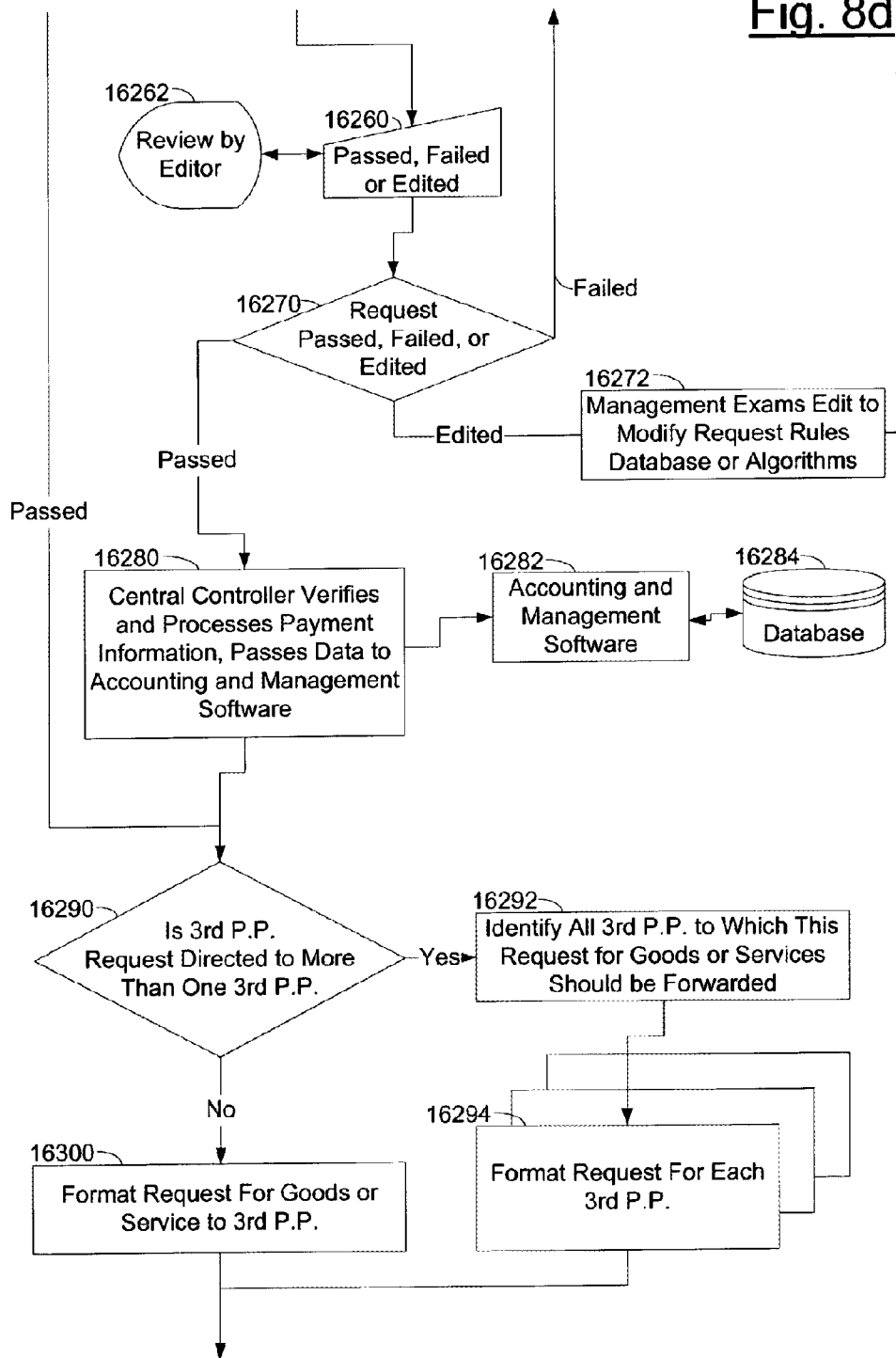


**Fig. 8c**





**Fig. 8d**



**Fig. 8e**

