

IN THE UNITED STATES DISTRICT COURT
FOR THE EASTERN DISTRICT OF TEXAS
MARSHALL DIVISION

WEATHERFORD INTERNATIONAL,
INC. and WEATHERFORD/LAMB, INC.

§
§
§
§
§
§
§

v.

NO. 2:09-CV-261-CE

HALLIBURTON ENERGY SERVICES,
INC., ET AL

MEMORANDUM OPINION AND ORDER

I. INTRODUCTION

Plaintiffs Weatherford International, Inc. and Weatherford/Lamb, Inc. (collectively, “Weatherford”) filed suit against Halliburton Energy Services, Inc. and General Plastics & Composites, L.P. (collectively, “Halliburton” or “Defendants”) on August 27, 2009, alleging infringement of U.S. Patent Nos. 6,712,153 (“the ‘153 Patent”) and 7,124,831 (“the ‘831 Patent”). On May 21, 2010, Halliburton counter-claimed against Weatherford alleging infringement of U.S. Patent Nos. 6,695,050 (“the ‘050 Patent”) and 5,540,279 (“the ‘279 Patent”). This memorandum opinion and order addresses the parties’ various claim construction disputes as to Weatherford’s patents-in-suit.

The ‘153 Patent issued on March 30, 2004 and the application leading to the ‘153 Patent was filed on June 27, 2001. The ‘831 Patent issued on October 24, 2006 and is based on an application filed on April 8, 2005. The ‘831 Patent is a continuation of the original application

leading to the '153 Patent and, therefore, the Weatherford patents-in-suit have substantially the same specification.¹

The Weatherford patents-in-suit are entitled “Resin Impregnated Continuous Fiber Plug with Non-Metallic Element System.” Weatherford asserts that Defendants infringe Claims 1, 2, 5, 7, 8, 10, 12, 13, 14, 15, 17, 20, 25, 29, 36, 41, 49, and 50 of the '153 Patent and Claims 1, 3, 5, 14, 15, 16, 18, 22, 24, 35, 36, 37, 41, and 42 of the '831 Patent. The patents-in-suit are related to downhole tools such as bridge plugs, frac-plugs, and packers having a non-metallic sealing element system. '153 Patent at 1:5-12. The invention provides a non-metallic element system:

which can effectively seal or pack-off an annulus under elevated temperatures. The element system can also resist high differential pressures without sacrificing performance or suffering mechanical degradation, and is considerably faster to drill-up than a conventional element system. In one aspect, the composite material comprises an epoxy blend reinforced with glass fibers stacked layer upon layer at about 30 to about 70 degrees.... The tool comprises a first and second support ring having one or more tapered wedges, a first and second expansion ring, and a sealing member disposed between the expansion rings and the support rings.

Id. at Abstract. Claim 1 of the '153 Patent is representative of the claims of the patents-in-suit and is reproduced below:

A non-metallic element system, comprising:

a first and second support ring each having two or more tapered wedges;

a first and second expansion ring each deformable to fill a gap formed between the tapered wedges of one of the support rings; and

a sealing member disposed between the first and second expansion rings.

¹ Because the specifications of the Weatherford patents-in-suit are essentially the same, for consistency and simplicity, the court will reference only the specification of the '153 Patent.

The court held a *Markman* hearing on May 18, 2011. After considering the submissions and the arguments of counsel, the court issues the following order concerning the parties' claim construction disputes.

II. GENERAL PRINCIPLES GOVERNING CLAIM CONSTRUCTION

“A claim in a patent provides the metes and bounds of the right which the patent confers on the patentee to exclude others from making, using or selling the protected invention.” *Burke, Inc. v. Bruno Indep. Living Aids, Inc.*, 183 F.3d 1334, 1340 (Fed. Cir. 1999). Claim construction is an issue of law for the court to decide. *Markman v. Westview Instruments, Inc.*, 52 F.3d 967, 970-71 (Fed. Cir. 1995) (en banc), *aff'd*, 517 U.S. 370 (1996).

To ascertain the meaning of claims, the court looks to three primary sources: the claims, the specification, and the prosecution history. *Markman*, 52 F.3d at 979. The specification must contain a written description of the invention that enables one of ordinary skill in the art to make and use the invention. *Id.* A patent's claims must be read in view of the specification, of which they are a part. *Id.* For claim construction purposes, the description may act as a sort of dictionary, which explains the invention and may define terms used in the claims. *Id.* “One purpose for examining the specification is to determine if the patentee has limited the scope of the claims.” *Watts v. XL Sys., Inc.*, 232 F.3d 877, 882 (Fed. Cir. 2000).

Nonetheless, it is the function of the claims, not the specification, to set forth the limits of the patentee's invention. Otherwise, there would be no need for claims. *SRI Int'l v. Matsushita Elec. Corp.*, 775 F.2d 1107, 1121 (Fed. Cir. 1985) (en banc). The patentee is free to be his own lexicographer, but any special definition given to a word must be clearly set forth in the specification. *Intellicall, Inc. v. Phonometrics, Inc.*, 952 F.2d 1384, 1388 (Fed. Cir. 1992). Although the specification may indicate that certain embodiments are preferred, particular

embodiments appearing in the specification will not be read into the claims when the claim language is broader than the embodiments. *Electro Med. Sys., S.A. v. Cooper Life Sciences, Inc.*, 34 F.3d 1048, 1054 (Fed. Cir. 1994).

This court's claim construction decision must be informed by the Federal Circuit's decision in *Phillips v. AWH Corporation*, 415 F.3d 1303 (Fed. Cir. 2005) (en banc). In *Phillips*, the court set forth several guideposts that courts should follow when construing claims. In particular, the court reiterated that "the *claims* of a patent define the invention to which the patentee is entitled the right to exclude." 415 F.3d at 1312 (emphasis added) (*quoting Innova/Pure Water, Inc. v. Safari Water Filtration Systems, Inc.*, 381 F.3d 1111, 1115 (Fed. Cir. 2004)). To that end, the words used in a claim are generally given their ordinary and customary meaning. *Id.* The ordinary and customary meaning of a claim term "is the meaning that the term would have to a person of ordinary skill in the art in question at the time of the invention, i.e., as of the effective filing date of the patent application." *Id.* at 1313. This principle of patent law flows naturally from the recognition that inventors are usually persons who are skilled in the field of the invention and that patents are addressed to and intended to be read by others skilled in the particular art. *Id.*

The primacy of claim terms notwithstanding, *Phillips* made clear that "the person of ordinary skill in the art is deemed to read the claim term not only in the context of the particular claim in which the disputed term appears, but in the context of the entire patent, including the specification." *Id.* Although the claims themselves may provide guidance as to the meaning of particular terms, those terms are part of "a fully integrated written instrument." *Id.* at 1315 (*quoting Markman*, 52 F.3d at 978). Thus, the *Phillips* court emphasized the specification as being the primary basis for construing the claims. *Id.* at 1314-17. As the Supreme Court stated

long ago, “in case of doubt or ambiguity it is proper in all cases to refer back to the descriptive portions of the specification to aid in solving the doubt or in ascertaining the true intent and meaning of the language employed in the claims.” *Bates v. Coe*, 98 U.S. 31, 38 (1878). In addressing the role of the specification, the *Phillips* court quoted with approval its earlier observations from *Renishaw PLC v. Marposs Societa’ per Azioni*, 158 F.3d 1243, 1250 (Fed. Cir. 1998):

Ultimately, the interpretation to be given a term can only be determined and confirmed with a full understanding of what the inventors actually invented and intended to envelop with the claim. The construction that stays true to the claim language and most naturally aligns with the patent’s description of the invention will be, in the end, the correct construction.

Phillips, 415 F.3d at 1316. Consequently, *Phillips* emphasized the important role the specification plays in the claim construction process.

The prosecution history also continues to play an important role in claim interpretation. Like the specification, the prosecution history helps to demonstrate how the inventor and the PTO understood the patent. *Id.* at 1317. Because the file history, however, “represents an ongoing negotiation between the PTO and the applicant,” it may lack the clarity of the specification and thus be less useful in claim construction proceedings. *Id.* Nevertheless, the prosecution history is intrinsic evidence that is relevant to the determination of how the inventor understood the invention and whether the inventor limited the invention during prosecution by narrowing the scope of the claims. *Id.*

Phillips rejected any claim construction approach that sacrificed the intrinsic record in favor of extrinsic evidence, such as dictionary definitions or expert testimony. The *en banc* court condemned the suggestion made by *Texas Digital Systems, Inc. v. Telegenix, Inc.*, 308 F.3d 1193 (Fed. Cir. 2002), that a court should discern the ordinary meaning of the claim terms (through

dictionaries or otherwise) before resorting to the specification for certain limited purposes. *Phillips*, 415 F.3d at 1319-24. The approach suggested by *Texas Digital*—the assignment of a limited role to the specification—was rejected as inconsistent with decisions holding the specification to be the best guide to the meaning of a disputed term. *Id.* at 1320-21. According to *Phillips*, reliance on dictionary definitions at the expense of the specification had the effect of “focus[ing] the inquiry on the abstract meaning of words rather than on the meaning of claim terms within the context of the patent.” *Id.* at 1321. *Phillips* emphasized that the patent system is based on the proposition that the claims cover only the invented subject matter. *Id.* What is described in the claims flows from the statutory requirement imposed on the patentee to describe and particularly claim what he or she has invented. *Id.* The definitions found in dictionaries, however, often flow from the editors’ objective of assembling all of the possible definitions for a word. *Id.* at 1321-22.

Phillips does not preclude all uses of dictionaries in claim construction proceedings. Instead, the court assigned dictionaries a role subordinate to the intrinsic record. In doing so, the court emphasized that claim construction issues are not resolved by any magic formula. The court did not impose any particular sequence of steps for a court to follow when it considers disputed claim language. *Id.* at 1323-25. Rather, *Phillips* held that a court must attach the appropriate weight to the intrinsic sources offered in support of a proposed claim construction, bearing in mind the general rule that the claims measure the scope of the patent grant.

III. TERMS IN DISPUTE

a. “Expansion Ring” / “Expandable Ring” (‘153 Patent – 1, 2, 5, 7, 8, 10, 12, 13, 14, 15, 17, 20, 25, 29, 36, 41, 49, 50)

Plaintiffs’ Proposed Construction	Defendants’ Proposed Construction
“ring of non-metallic material that spreads out under high pressure and/or temperature conditions”	“a ring that flows and fills a gap between the extended wedges so that no fluid is trapped and an effective fluid seal is maintained”

The parties agree that “expansion ring” and “expandable ring” should be treated the same for claim construction purposes. Both parties agree that the construction includes the term “ring,” but disagree as to the meaning of the term “expansion.” Weatherford argues that the court should construe “expansion ring” to mean a “ring of non-metallic material that spreads out under high pressure and/or temperature conditions.” According to Weatherford, this construction is supported by the specification, which explains that the expansion ring “may be manufactured from any flexible plastic, elastomeric, or resin material which flows at a predetermined temperature, such as Teflon®.” ‘153 Patent at 4:62–5:10. “At high temperatures, the expansion ring 230, 235 expands radially outward from the body 250 and flows across the outer surface of the body 250.” *Id.* In a preferred embodiment, “the expansion ring 230, 235 fills the voids created between the cuts 247 of the support ring 240, 245, thereby providing an effective seal.” *Id.*

Defendants, on the other hand, argue that the court should construe “expansion ring” to mean “a ring that flows and fills a gap between the extended wedges so that no fluid is trapped and an effective fluid seal is maintained.” Defendants’ proposed construction is based on the doctrine of prosecution history disclaimer. During prosecution of the ‘153 Patent, the Patent Office rejected the following claims of the ‘153 Patent in light of the *Harris* and *Hushbeck* references:

32. A non-metallic element system, comprising:

a first and second support ring having one or more tapered wedges;

a first and second expansion ring; and

a sealing member disposed between the expansion and support rings.

* * *

35. The element system of claim 34 wherein the expansion ring flows and fills a gap formed between the extended wedges.

Ex. 9, attached to Defendants' Responsive Claim Construction Brief, Dkt. No. 114. The examiner explained that *Hushbeck* discloses the use of non-metallic materials, and *Harris* discloses all of the other limitations of these two claims. *Id.* In response, Weatherford distinguished the rejected claims on the following grounds:

The claimed invention provides an expansion ring that flows and fills a gap formed between the extended wedges so that no fluid is trapped and an effective fluid seal is maintained. Accordingly, a combination of *Harris* and *Hushbeck et al.* does not motivate or suggest at least claims 35, 46, and 61-88, that recite this limitation. Accordingly, withdrawal of the rejection and allowance of the claims is respectfully requested.

Id. (emphasis added). Defendants argue that, in distinguishing Claims 32 and 35, Weatherford limited the claimed "expansion ring" to a ring that "flows and fills a gap formed between the extended wedges so that no fluid is trapped and an effective fluid seal is maintained."

The court, however, disagrees with Defendants and concludes that Weatherford's prosecution statements do not rise to the level of a clear disclaimer. Despite Weatherford's attempt to distinguish the *Harris* and *Hushbeck* prior art on the grounds outlined above, the examiner again rejected Weatherford's claims, stating "it is noted that the features upon which applicant relies (i.e., expansion ring flows and fills a gap between the extended wedges so that no fluid is trapped and an effective fluid seal is maintained) are not recited in the rejected claim(s)."

Ex. 8 at 9, attached to Defendants' Responsive Claim Construction Brief, Dkt. No. 114. In response, Weatherford amended various claims to include the "deformable to fill" or "flows...to fill" limitations, but at no point did Weatherford add any language related to the "so that no fluid is trapped and an effective fluid seal is maintained" limitation. Ex. 9 at 2-9, attached to Defendants' Responsive Claim Construction Brief, Dkt. No. 114. Furthermore, in its response to the examiner's second rejection, Weatherford argued that none of the cited prior art references disclose "a first and second expansion ring each deformable to fill a gap formed between the tapered wedges of one of the support rings, as recited in base claims 32, 43, 61, 67, and 81..." *Id.* at 10. And finally, Weatherford distinguished *Harris*, allegedly disclosing an expansion ring, on the basis that "the slotted backup rings 21A, 22A do not flow and fill a gap formed between the pedals of the expanding gage ring 21, 22." *Id.*

"Although prosecution history can be a useful tool for interpreting claim terms, it cannot be used to limit the scope of a claim unless the applicant took a position before the PTO that would lead a competitor to believe that the applicant had disavowed coverage of the relevant subject matter." *Schwing GmbH v. Putzmeister Aktiengesellschaft*, 305 F.3d 1318, 1324 (Fed. Cir. 2002). The Federal Circuit has, therefore, "consistently rejected prosecution statements too vague or ambiguous to qualify as disavowal of claim scope." *Omega Eng'g., Inc. v. Raytek Corp.*, 334 F.3d 1314, 1325 (Fed. Cir. 2003); *see also Rexnord Corp. v. Laitram Corp.*, 274 F.3d 1336, 1347 (Fed. Cir. 2001). As such, for prosecution disclaimer to apply, the allegedly disavowing actions must be both "clear and unmistakable." *Omega Eng'g.*, 334 F.3d at 1324-26. Here, Weatherford refused to add a limitation directed to the lack of trapped fluid and the effectiveness of a seal, while at the same time attempting to distinguish the rejected claims on other grounds. As such, considering the prosecution history as a whole, the court is not

convinced that Weatherford made a clear disavowal restricting the claimed “expansion ring” to “a ring that flows and fills a gap between the extended wedges so that no fluid is trapped and an effective fluid seal is maintained.” Accordingly, Defendants’ proposed construction is rejected.

The court agrees with Weatherford that its proposed construction accurately captures the specification’s description of the claimed “expansion ring.” The court, therefore, construes “expansion ring” to mean a “ring of non-metallic material that spreads out under high pressure and/or temperature conditions.” *See* ‘153 Patent at 4:62–5:10.

b. “Cone” (‘153 Patent – 5, 7, 8, 10, 20, 25, 41, 49, 50; ‘831 Patent – 1, 3, 5, 14, 15, 16, 18, 22, 24, 35, 36, 37, 41, 42)

Plaintiff’s Proposed Construction	Defendants’ Proposed Construction
“component with a generally cylindrical inner surface and an outer surface having a sloped portion that contacts and expands an adjacent component”	“rigid element with a sloped outer surface and generally cylindrical inner surface for expanding an adjacent component radially outward”

The term “cone” appears in claims in both the ‘153 and ‘831 Patents. There are two types of “cones” described in the specification: (1) inner cones 220 and 225; and (2) slip cones 320 and 325. Both types of cones serve the same purpose and operate in the same way – i.e., they act as ramps to radially expand surrounding components while at the same time transferring axial force toward the packer element. *See* ‘153 Patent at 5:19-5:27; 5:64-5:66. The primary difference between the two cones is that slip cones expand slips, and inner cones expand support rings.

Despite the slightly different usages of the cones, the parties agree that all instances of the term “cone” in the claims of both patents should be given the same meaning. The parties further agree that the outer surface of the cone is “sloped.” Finally, the parties generally agree that the

cone expands an adjacent or surrounding component. The parties' dispute, therefore, centers on whether, as Defendants argue, the cone must be "rigid."

According to Defendants, the cone must be "rigid" so as to exclude "packer elements" with sloped outer surfaces. Defendants again rely on a prosecution disclaimer argument. In the application leading to the '831 Patent, the examiner rejected certain claims over U.S. Patent Nos. 6,394,180 ("*Berscheidt*") and 6,167,963 ("*McMahan*"). Ex. 12 at 5-7, attached to Plaintiffs' Reply Claim Construction Brief, Dkt. No. 120. Weatherford amended these claims to include a limitation, among other numerous limitations, of "a first and second pair of cones." *Id.*, Ex 13 at 1-7. In its response, Weatherford stated the following:

Regarding claims 1 and 25, neither *Berscheidt* [sic] nor *McMahan* teach, suggest, or, disclose 'a first and second pair of cones' as recited in amended claims 1 and 25. *Berscheidt* illustrates only a first pair of cones, or slip wedges (60, see Fig. 2). *McMahan* also only describes a first pair of cones (28 and 40, see col. 3 lines 16-20).

Id. at 10. Defendants argue that, in making these statements, Weatherford admitted that both *McMahan* and *Berscheidt* disclose a first pair of cones, but argued that none of the other components disclosed in those two references were "cones," including the sloped rubber packer elements found in each reference. Accordingly, Defendants contend that the any construction of the term "cone" must exclude sloped rubber packer elements.

The court disagrees with Defendants' interpretation of the prosecution history statements on which they rely. Although Weatherford implied that numerous components of *Berscheidt* and *McMahan* were not cones "as recited in [the] amended claims," Weatherford never stated that they were not cones because they were made of rubber or because they were packing elements. *See id.* Further, because Weatherford implied that numerous and different components of *Berscheidt* and *McMahan* were not cones – including components that were and were not rigid

and components that were and were not packer elements – there is no express or implied distinction between components that were rigid or non-rigid or between components that were packer elements or non-packer elements. Thus, contrary to Defendants’ assertions, Weatherford never made a “clear and unmistakable” disavowal that the cone could not be a packing element or had to be rigid. *See Omega Eng’g.*, 334 F.3d at 1328.

Defendants further argue that Weatherford made a similar disclaimer during the prosecution of U.S. Patent Application No. 12/646,066 (the “’066 Patent”), which shares a common specification and claims priority to both the ’153 and ’831 Patent applications. *See Ex. 4* at 3, 4, 8, attached to Defendants’ Responsive Claim Construction Brief, Dkt. No. 114. During the prosecution of that application, Weatherford distinguished several references, including the *Harris* and *Hushbeck* references discussed above, on the grounds that they did not disclose “a first non-metallic cone.” *Id.* Defendants contend that Weatherford clearly explained that the rubber packer elements with sloped outer surfaces in *Harris* and *Hushbeck* were not “cones.” Having carefully reviewed the prosecution history on which Defendants rely, the court rejects Defendants’ contention that Weatherford clearly disavowed non-rigid cones in distinguishing *Harris* and *Hushbeck*. Although Weatherford explained that *Harris* and *Hushbeck* do not teach “a first non-metallic cone,” they never stated why the references do not meet the limitation and did not indicate that the limitation was not met because the cones of *Harris* and *Hushbeck* were not rigid. As such, the court is not convinced that the ’066 Patent prosecution history statements on which Halliburton relies rise to the level of a prosecution history disclaimer.

The conclusion that the cones can be non-rigid, semi-rigid, or rigid is further confirmed by the prosecution history of the ’153 Patent. In the first office action for the application leading to the ’153 Patent, the examiner found “cones” to be the outer packing elements in U.S. Patent

No. 5,701,959 (“*Hushbeck*”). *See* Ex. 6 at 3, attached to Plaintiffs’ Opening Claim Construction Brief, Dkt. No. 107. In a subsequent office action, the examiner also found that U.S. Patent No. 4,397,351 (“*Harris*”) “discloses a first (23) and second cone (24) each disposed about opposite ends of the sealing member.” Ex. 8 at 3, attached to Plaintiffs’ Opening Claim Construction Brief, Dkt. No. 107. These prior art components found to be “cones” by the examiner in both the *Hushbeck* and *Harris* references are “non-rigid” packing elements and, thus, the examiner implicitly rejected Defendants’ proposed “rigid” limitation. Weatherford did not dispute the examiner’s findings and instead argued around the *Harris* and *Hushbeck* references based on other claim limitations. Considering this, the prosecution history is, at best, “inconclusive,” and therefore, the court rejects Defendants’ argument that the “cones” must be rigid. *See Rexnord*, 274 F.3d at 1347.

The court adopts Weatherford’s proposed construction because it is supported by the specification’s description of the claimed “cones.” The specification of the patents-in-suit describes inner cones 220 and 225 of the non-metallic element system in detail. *See* ‘153 Patent at 5:11-28; 5:52-6:2; 6:55-62. As shown in Figures 2 and 5, cones 220 and 225 have an interior surface that is generally cylindrical and an outer surface that is sloped. *See id.* Further, the specification confirms that the expansion ring 230, adjacent to the cone 220, is tapered to complement an outer sloped surface of cone 220. *See id.* at 5:1-4. The specification also describes the second type of cones in detail – i.e., the slip cones. *See id.* at 6:43-59; 7:27-37. Like cones 220 and 225, slip cones 320 and 325 have an interior surface that is generally cylindrical and an outer surface that is sloped. *See id.* at Figures 5, 6, 6a. Further, the specification confirms that cones 320 and 325 have an outer surface that is tapered, which rests underneath the inner surface of slips 310 and 315. *See id.* at 6:54-56; 7:29-31. Considering this,

the court concludes that Weatherford’s proposed construction – i.e., “*component with a generally cylindrical inner surface and an outer surface having a sloped portion that contacts and expands an adjacent component*” – gives full meaning, based on the specification, to the inner and outer surfaces of the cone.

Further, the specification explains that, as recited in Weatherford’s proposed construction, the cone’s outer surface “contacts and expands an adjacent component.” For example, for the cones of the non-metallic element system, “the tapered first section [of the cone] urges the expansion ring 230, 235 radially outward from the body 250 as the element system 200 is activated” and a “compressive force causes the expansion rings 230, 235 to flow and expand as they are forced across the tapered section of the cones 220, 225.” *Id.* at 5:16-19, 52-55. Likewise, for the slip cones, the “tapered first end [of the slip cone] rests underneath the tapered inner surface of the slips” so that the slips “move up and across the tapered surface of the cones 320, 325.” *Id.* at 6:54-59; 7:29-31. The specification thus explains that the cones contact and expand adjacent components.

In conclusion, the court adopts Weatherford’s proposed construction. The term “cone” means “component with a generally cylindrical inner surface and an outer surface having a sloped portion that contacts and expands an adjacent component.”

c. Tapered Wedges (‘153 Patent – 1, 2, 5, 7, 8, 10, 12, 13, 14, 15, 17, 20, 25, 29, 36, 41, 49, 50; ‘831 Patent – 3, 22)

Plaintiff’s Proposed Construction	Defendants’ Proposed Construction
“section of the support ring having angled inner surfaces and essentially cylindrical outer surfaces”	“wedges that vary in width and thickness along their length” -OR- “section of a support ring having angled inner surfaces and essentially cylindrical outer surfaces that varies in width and thickness along its length”

The term “tapered wedges” appears in both the ‘153 and ‘831 Patents. Claim 1 of the ‘153 Patent is representative and recites: “A non-metallic element system, comprising: a first and second support ring each having two or more tapered wedges....” Weatherford and Defendants agree that the term “tapered wedges” has the same meaning in both patents.

A preferred embodiment illustrates that the “tapered wedge” prevents slippage of the non-metallic element system relative to the surrounding tubular. *See* ‘153 Patent at 4:49-61, 7:37-46. In a preferred embodiment, the “tapered wedge” hinges radially outward as the support ring moves axially across the outer surface of the expansion ring, thereby causing the wedges to extend radially outward to engage the surrounding tubular. *Id.*

Weatherford argues that the court should construe the term to mean a “section of the support ring having angled inner surfaces and essentially cylindrical outer surfaces.” According to Weatherford, its proposed construction is supported by both the claims and the specification. First, Weatherford argues that, considering the claim language itself, “tapered wedges” are part of the claimed “support ring” – i.e., Claim 1 of the ‘153 Patent provides that “a first and second support ring each having two or more tapered wedges.” *See also id.* at Claims 12, 29, 36, and 50. Second, Weatherford argues that its proposed construction gives meaning to both “tapered” and “wedge.” The specification expressly provides that the inner surfaces of the wedges are angled: “[s]till referring to FIG. 3, the wedges 248 are angled outwardly from a center line or axis of the support ring...the angled wedges 248 hinge radially outward....” *Id.* at 4:47-51; *see also id.* at 5:1-2 (the expansion ring is “tapered corresponding to a complimentary angle of the wedges 248”). Furthermore, Figures 2 and 3 depict the “tapered wedges” 245 and 248 with an angled inner surface and an essentially cylindrical outer surface:

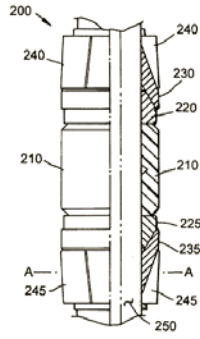

Fig.2

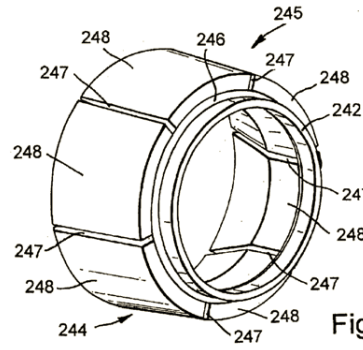

Fig.3

As such, Weatherford argues that its proposed construction has support in both the claim language and the specification.

In response, Defendants argue that Weatherford’s proposed construction treats the term “tapered” as mere surplusage. Defendants propose that the term “tapered” should be equated to the phrase “vary in width and thickness along their length.” To support this proposed construction, Defendants first argue that the patents-in-suit disclose two different types of segmented support rings: (1) rings with trapezoidal wedges, such as ring 240 illustrated in Figures 2 and 5; and (2) rings with rectangular wedges, such as ring 245 illustrated in Figures 3 and 4.

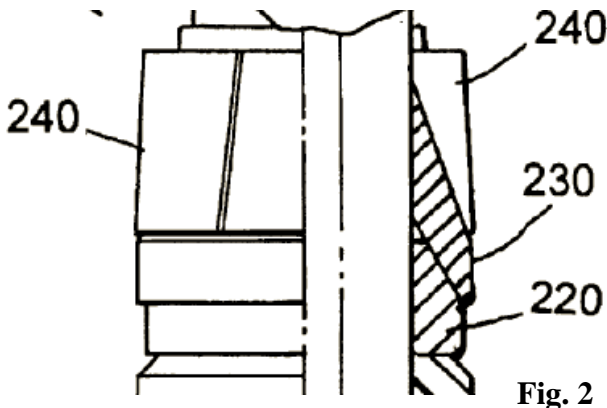

Fig. 2

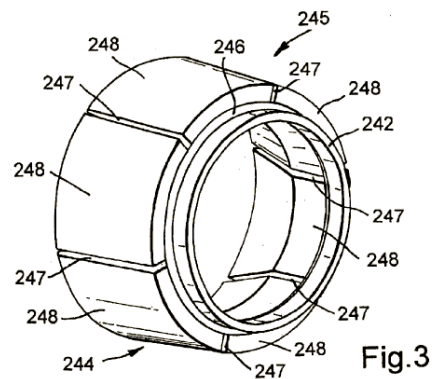

Fig.3

Id. at Figures 2 and 3. Defendants next argue that, by drafting the claims at issue to cover only “*tapered* wedges,” Weatherford limited the claims to trapezoidal wedge support rings – i.e., “wedges that vary in width and thickness along their length.”

The court rejects Defendants’ proposed construction. The term “tapered” is used fourteen times in the “Detailed Description of the Preferred Embodiment” section of the patents-in-suit, and in each instance, “tapered” is referred to as the outward angle from the center or axis of the tool for a component – not as the angle between different wedges as Defendants contend. The term “tapered” is used equivalently in the context of expansion rings, cones, slips, and wedges:

The first section of the expansion ring 230, 235 is tapered corresponding to a compl[e]mentary angle of the wedges 248. A second section of the expansion ring 230, 235 is also tapered to compliment a slopped surface of the cone 220, 225.

Each slip 310, 315 comprises a tapered inner surface conforming to the first end of the cone 320, 325.

As stated above, the cones 320, 325 comprise a tapered first end which rests underneath the tapered inner surface of the slips 310, 315.

Id. at 4:67-5:4; 6:24-26; 6:54-56. Each of these components has a tapered angle that is complementary to the adjacent component’s tapered angle. *Id.*; *see also id.* at Figure 2. Thus, the specification uses the term “tapered” to refer to the component’s angled surface, whether it is the surface of the expansion ring, cone, slip, or wedge. Furthermore, certain claims of the ‘153 Patent describe the tapered wedges as having an inner surface that is angled. *See* Claims 4, 18.

At no point in the specification or claims is the term “tapered” equated to “varies in width and thickness along its length.” The terms “width,” “thick,” and “thickness” are never used in the specification. Further, there is no discussion of “rectangular” wedges or “trapezoidal” wedges. Although tapered is used consistently for expansion rings, cones, slips, and wedges,

Defendants attempt to create a distinction for the term “tapered” as applied to wedges based solely on an alleged variance in the shape of the support rings (elements 240, 245) depicted in Figures 2 and 3, arguing that these differences necessarily create two different embodiments of the support rings – i.e., trapezoidal wedge support rings and rectangular wedge support rings. There is, however, no discussion in the specification explaining that the wedges shown in Figure 2 are different from the wedges shown in Figure 3. Indeed, Figure 4 is described as showing a cross-sectional view of Figure 2 (*id.* at 4:32-33), and the support ring of Figure 4 shows “equally spaced longitudinal cuts,” which implies that the wedges in Figure 2 are not trapezoidal as Defendants argue. However, even if the court were to assume that the figures depict different embodiments, this assumption would not overcome the specification’s repeated and consistent treatment of the term “tapered” as referring to the angled portions of the component that correspond to a complementary angle of the adjacent component. As such, the court rejects Defendants’ proposed construction.

In conclusion, the court adopts Weatherford’s proposed construction because, as discussed above, it accurately captures the specification’s disclosures regarding the “tapered wedge.” As such, the court construes “tapered wedge” to mean “section of the support ring having angled inner surfaces and essentially cylindrical outer surfaces.”

IV. CONCLUSION

The court adopts the constructions set forth in this opinion for the disputed terms of the Weatherford patents-in-suit. The parties are ordered that they may not refer, directly or indirectly, to each other’s claim construction positions in the presence of the jury. Likewise, the parties are ordered to refrain from mentioning any portion of this opinion, other than the actual definitions adopted by the court, in the presence of the jury. Any reference to claim construction

proceedings is limited to informing the jury of the definitions adopted by the court.

It is so ORDERED.

SIGNED this 5th day of August, 2011.

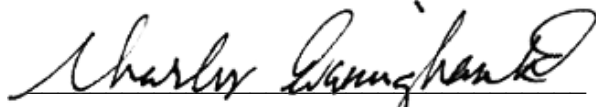

CHARLES EVERINGHAM IV
UNITED STATES MAGISTRATE JUDGE