

**IN THE UNITED STATES DISTRICT COURT
FOR THE EASTERN DISTRICT OF TEXAS
MARSHALL DIVISION**

MOBILE TELECOMMUNICATIONS
TECHNOLOGIES, LLC

v.

CLEARWIRE CORP., et al.

§
§
§
§
§
§

Case No. 2:12-cv-308-JRG-RSP

**CLAIM CONSTRUCTION
MEMORANDUM AND ORDER**

On June 7, 2013, the Court held a claim construction hearing concerning U.S. Patent No. 5,590,403 (the “‘403 Patent”). Having considered the arguments and evidence presented by the parties at the hearing and in their briefing (Dkt. Nos. 60, 61, and 64), the Court issues this Claim Construction Order.

The ‘403 Patent generally relates to a system for providing two-way communication between a plurality of transmitters and mobile units. ‘403 Patent at Abstract. The patent addresses techniques in which improved communication is provided over a relatively large area. ‘403 Patent at 1:8-14. The patent includes two independent claims. Claim 1 is directed toward concepts in which the transmitters are divided into a first and second set of transmitters. During a first time period a first block of information is transmitted by the first and second sets of transmitters in simulcast. During a second time period the first set of transmitters transmits a second block of information and the second set of transmitters transmits a third block of information. Independent claim 10 relates to a concept in which a region of space is divided into a plurality of zones, each zone having at least one base transmitter. A first set of transmitters assigned to a first zone transmits a first information signal in simulcast and a second set of transmitters assigned to a second zone transmits a second information signal in simulcast.

At least one transmitter assigned to the first set of transmitters may be dynamically reassigned from the first zone to the second zone.

APPLICABLE LAW

“It is a ‘bedrock principle’ of patent law that ‘the claims of a patent define the invention to which the patentee is entitled the right to exclude.’” *Phillips v. AWH Corp.*, 415 F.3d 1303, 1312 (Fed. Cir. 2005) (en banc) (quoting *Innova/Pure Water Inc. v. Safari Water Filtration Sys., Inc.*, 381 F.3d 1111, 1115 (Fed. Cir. 2004)). To determine the meaning of the claims, courts start by considering the intrinsic evidence. *See id.* at 1313. *C.R. Bard, Inc. v. U.S. Surgical Corp.*, 388 F.3d 858, 861 (Fed. Cir. 2004); *Bell Atl. Network Servs., Inc. v. Covad Commc’ns Group, Inc.*, 262 F.3d 1258, 1267 (Fed. Cir. 2001). The intrinsic evidence includes the claims themselves, the specification, and the prosecution history. *See Phillips*, 415 F.3d at 1314; *C.R. Bard, Inc.*, 388 F.3d at 861. Courts give claim terms their ordinary and accustomed meaning as understood by one of ordinary skill in the art at the time of the invention in the context of the entire patent. *Phillips*, 415 F.3d at 1312–13; *Alloc, Inc. v. Int’l Trade Comm’n*, 342 F.3d 1361, 1368 (Fed. Cir. 2003).

The claims themselves provide substantial guidance in determining the meaning of particular claim terms. *Phillips*, 415 F.3d at 1314. First, a term’s context in the asserted claim can be very instructive. *Id.* Other asserted or unasserted claims can also aid in determining the claim’s meaning because claim terms are typically used consistently throughout the patent. *Id.* Differences among the claim terms can also assist in understanding a term’s meaning. *Id.* For example, when a dependent claim adds a limitation to an independent claim, it is presumed that the independent claim does not include the limitation. *Id.* at 1314–15.

“[C]laims ‘must be read in view of the specification, of which they are a part.’” *Id.* (quoting *Markman v. Westview Instruments, Inc.*, 52 F.3d 967, 979 (Fed. Cir. 1995) (en banc)).

“[T]he specification ‘is always highly relevant to the claim construction analysis. Usually, it is dispositive; it is the single best guide to the meaning of a disputed term.’” *Id.* (quoting *Vitronics Corp. v. Conceptoronic, Inc.*, 90 F.3d 1576, 1582 (Fed. Cir. 1996)); *Teleflex, Inc. v. Ficosa N. Am. Corp.*, 299 F.3d 1313, 1325 (Fed. Cir. 2002). This is true because a patentee may define his own terms, give a claim term a different meaning than the term would otherwise possess, or disclaim or disavow the claim scope. *Phillips*, 415 F.3d at 1316. In these situations, the inventor’s lexicography governs. *Id.* The specification may also resolve ambiguous claim terms “where the ordinary and accustomed meaning of the words used in the claims lack sufficient clarity to permit the scope of the claim to be ascertained from the words alone.” *Teleflex, Inc.*, 299 F.3d at 1325. But, “[a]lthough the specification may aid the court in interpreting the meaning of disputed claim language, particular embodiments and examples appearing in the specification will not generally be read into the claims.” *Comark Commc’ns, Inc. v. Harris Corp.*, 156 F.3d 1182, 1187 (Fed. Cir. 1998) (quoting *Constant v. Advanced Micro-Devices, Inc.*, 848 F.2d 1560, 1571 (Fed. Cir. 1988)); *see also Phillips*, 415 F.3d at 1323. The prosecution history is another tool to supply the proper context for claim construction because a patent applicant may also define a term in prosecuting the patent. *Home Diagnostics, Inc., v. Lifescan, Inc.*, 381 F.3d 1352, 1356 (Fed. Cir. 2004) (“As in the case of the specification, a patent applicant may define a term in prosecuting a patent.”).

Although extrinsic evidence can be useful, it is “less significant than the intrinsic record in determining the legally operative meaning of claim language.” *Phillips*, 415 F.3d at 1317 (quoting *C.R. Bard, Inc.*, 388 F.3d at 862). Technical dictionaries and treatises may help a court understand the underlying technology and the manner in which one skilled in the art might use claim terms, but technical dictionaries and treatises may provide definitions that are too broad or

may not be indicative of how the term is used in the patent. *Id.* at 1318. Similarly, expert testimony may aid a court in understanding the underlying technology and determining the particular meaning of a term in the pertinent field, but an expert’s conclusory, unsupported assertions as to a term’s definition is entirely unhelpful to a court. *Id.* Generally, extrinsic evidence is “less reliable than the patent and its prosecution history in determining how to read claim terms.” *Id.*

CONSTRUCTION OF DISPUTED TERMS

A. “transmitter” / “base transmitter”

MTEL Proposed Construction	Clearwire Proposed Construction
No construction necessary	communications device having a data input, a control logic, modulators, a combiner, power amplifier(s), and antenna(e)

The parties first dispute the meaning of the terms “transmitter” and “base transmitter.” The Court finds that the terms “transmitter” and “base transmitter” should be given their plain and ordinary meaning.

Clearwire argues that the terms “transmitter” and “base transmitter” should be limited to the structure disclosed in Figures 13 and 14:

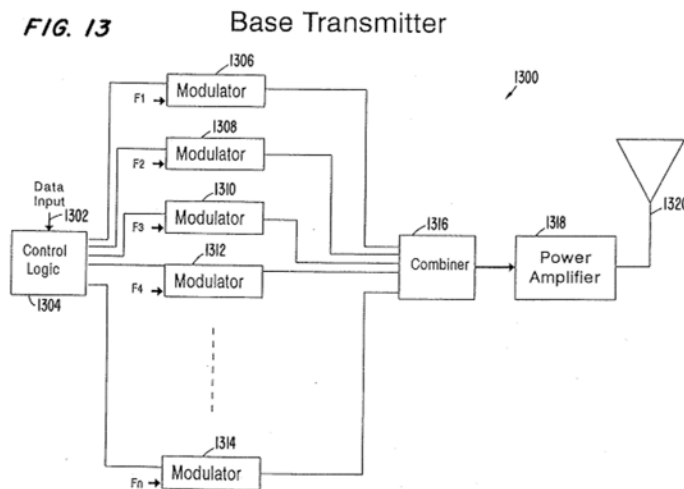

The Court rejects this position. The specification clearly identifies Figure 13, for example, as “show[ing] a first preferred embodiment of a base transmitter 1300.” ‘403 Patent at 15:44-46. Similarly, the specification describes Figure 14 as “show[ing] a second preferred embodiment of a base transmitter 1400.” *Id.* at 16:7-8. “Although the specification may aid the court in interpreting the meaning of disputed claim language, particular embodiments and examples appearing in the specification will not generally be read into the claims.” *Comark Commc’ns*, 156 F.3d at 1187. Although a person of ordinary skill in the art might understand the structure shown in Figures 13 and 14 to be a transmitter, it would be inappropriate to limit the term “transmitter” to **only** that structure, especially in light of the qualifying language of the specification. Thus, the Court declines to import the precise structure shown in Figures 13 and 14 into the claims.

MTEL argues that no construction is necessary for the terms “transmitter” and “base transmitter,” but at the hearing, declined to provide an explanation as to how these terms would be understood by a person of ordinary skill in the art. MTEL did imply, however, that a single unit transmitting multiple signals might be considered multiple transmitters. MTEL further argued that because both independent claims at issue are method claims, the infringement lies in a device’s ability to “transmit” rather than its specific structure. Although the Court recognizes that claims 1 and 10 are method claims, a person of ordinary skill in the art would understand the terms “transmitter” and “base transmitter” to refer to a structural unit, and thus, the number of transmitters in a given system or method is dependent on structure, not function. The specification supports such an interpretation: “[**e**]ach base transmitter unit . . . receives transmitter control data and message data transmitted from satellite 606.” ‘403 Pat. at 15:42-44.

(Emphasis added.) For this reason, the Court rejects MTEL’s implication that transmitting multiple signals or outputs from a single structural unit can suffice as multiple transmitters.

Finally, as discussed in further detail below, the Court rejects Clearwire’s proposition that a “transmitter” must be spatially separated or geographically dispersed from other transmitters, because Clearwire has provided no evidence to support reading such a limitation into the claims.

B. “plurality of transmitters” (claims 1, 10) / “plurality of zones” (claim 10)

MTEL Proposed Construction	Clearwire Proposed Construction
No construction necessary	at least two transmitters
In the alternative: “more than one transmitter”	at least two zones
In the alternative: “more than one zone”	

The primary dispute with regard to “plurality” relates to whether a “plurality” of a particular item requires two of those items or would include one plus some fraction of the item.

As Clearwire notes, the Federal Circuit has found on multiple occasions that “plurality” ordinarily means “at least two.” *Apple Inc. v. Samsung Elec. Co.*, 695 F.3d 1370, 1378 (Fed. Cir. 2012); *Bilstad v. Wakalopulos*, 386 F.3d 1116, 119 (Fed. Cir. 2004); *ResQNet.com, Inc. v. Lansa, Inc.*, 346 F.3d 1374, 1384 (Fed. Cir. 2003). The text of the ‘403 patent provides no reason to deviate from this general rule. *See, e.g.*, claim 10 (specifying both a “first zone” and “second zone,” and a “first set” and “second set” of transmitters). The Court also notes that, when given the opportunity at the claim construction hearing, MTEL did not object to the Court’s proposed construction of “at least two “transmitters” and “at least two zones.” The Court finds that a “plurality of transmitters” means “at least two transmitters,” and a “plurality of zones” means “at least two zones.”

C. “zone[s]”

MTEL Proposed Construction	Clearwire Proposed Construction
No construction necessary	transmitters the network operations center assigns to the same region of space, the boundary of which is roughly defined by the coverage areas of a set of transmitters

The Court finds that a “zone” is a “portion of a region of space,” as the claim context requires such a construction. For example, claim 10 states “a region of space divided into a plurality of zones.” In this way, the claims themselves define a zone as a portion of a region of space. The specification also supports this construction: “[g]enerally, the communication system of the present invention roughly divides various regions of space into portions called zones.” ‘403 Pat. at 9:40-43.

The Court rejects Clearwire’s contention that a zone consists of its assigned transmitters, and notes that such a construction would directly conflict with the claim language. Claim 10 recites “a first set of base transmitters assigned to a first zone” and “a second set of base transmitters assigned to second zone.” Thus, the assignment of transmitters to a zone is defined itself by the claim language, and grouping that assignment into the definition of the term “zone” would be both redundant and confusing to a jury.

D. “set of transmitters” (claim 1) / “set of base transmitters” (claims 10, 11)

MTEL Proposed Construction	Clearwire Proposed Construction
No construction necessary	transmitters spatially dispersed throughout a geographic region

The primary dispute relates to whether the transmitters must be spatially dispersed. A dispute also is presented as to whether the term requires multiple transmitters. The Court finds

that “set of transmitters” means “a set of at least two transmitters” and “set of base transmitters” means “a set of at least two base transmitters.”

The Court rejects Clearwire’s contention that a “set” of transmitters must be geographically dispersed. The claims merely recite a set of transmitters. Clearwire attempts to read into the claims the particular embodiments of the specification but does not point to language of disavowal in the specification or the prosecution history. In fact, the claims themselves include their own geographical limitations (with regard to regions of space divided into zones), further counseling against reading the features of the preferred embodiments into the definition of the terms “set of transmitters” and “set of base transmitters.”

Similarly, the Court rejects MTEL’s contention that a “set of transmitters” can be a single transmitter. The plain plural language of the claim (“transmitters_g”) requires at least two transmitters. Further, as conceded by MTEL at the hearing, the remaining limitations of claim 10 clearly shows that if a “set” contained just one transmitter, the method and system claimed would be incapable of functioning in the manner recited.

E. “transmitting in simulcast” (claim 1) / “transmitted in simulcast” (claim 10)

MTEL Proposed Construction	Clearwire Proposed Construction
transmitting information over two or more channels or modes	broadcasting identical signals simultaneously

The Court finds that a person of ordinary skill in the art would understand “transmitting in simulcast” to mean “transmitting the same information at the same time.” At the hearing, each party largely agreed with this language, but each proposed minor modifications.

Clearwire proposes that the construction should require that the same **signal** be transmitted, rather than the same **information**. Clearwire provides no rationale for requiring that

the signals be identical, and in fact cites to the specification's recitation that "simulcast technology provides multiple transmitters . . . transmitting the **same information**." '403 Pat. at 1:50-53; *see also* (Dkt. No. 61 at 21). Further, as MTEL correctly notes, the patent explicitly states that "good simulcast practice" has differing signals:

It should also be understood that in accordance with good simulcast practice, the respective carrier frequencies between adjacent based transmitters, such as base transmitter 612 and base transmitter 614 in Figure 6, should be slightly offset.... This frequency offset is preferably on the order of 10-20 hertz.

See '403 Pat. at 13:39-46. Thus, the "identical signal" requirement is not only absent from the claims, but the specification specifically envisions a simulcasting embodiment that broadcasts the same information without the use of identical signals. Thus, including such language in the Court's construction would be directly contrary to the specification.

MTEL proposes that the construction be adopted with the addition of ". . . over two or more channels or modes." In support of this proposal, MTEL cites to the specification's discussion of multi-carrier modulation. *See* (Dkt. No. 60 at 15); '403 Pat. at 13:3-15:40. The Court first notes that MTEL provides no support for its assertion that the limitation of ". . . over two or more channels or modes" should be read into the claims, and thus, the Court declines to import that limitation from the specification.

MTEL also implicitly argues that, by using multi-carrier modulation, a single transmitter may operate in simulcast with itself. The Court notes that there is no support in the specification or prosecution history for the suggestion that this meets the definition of "simulcast" as defined by the '403 Patent. In fact, the specification only envisions "multi-carrier simulcast" with two transmitters, which directly contradicts MTEL's implication:

In another embodiment, the invention is directed to a multi-carrier simulcast transmission system for transmitting in a desired frequency band a message contained in an information signal, the system comprising a

first transmitter means for transmitting an information signal by generating a first plurality of carrier signals within the desired frequency band and by modulating the first plurality of carrier signals to convey the information signal, and a second transmitter means, spatially separated from the first transmitter, for transmitting the information signal in simulcast with the first transmitter by generating a second plurality of carrier signals at substantially the same frequencies as the first plurality of carrier signals and by modulating the second plurality of carrier signals to convey the information signal.

‘403 Pat. at 5:30-43. Thus, the Court rejects MTEL’s proposal to add “. . . over two or more channels or modes” to the Court’s construction, and in doing so, rejects MTEL’s implicit argument that a single transmitter can operate in simulcast with itself by using multi-carrier modulation.

F. “dynamically reassigning” claims 10, 11

MTEL Proposed Construction	Clearwire Proposed Construction
No construction necessary	redefining zonal boundaries by the network operations center reassigning transmitter(s) to a different region of space

The Court finds that “dynamically reassigning” should be given its plain and ordinary meaning.

Neither party objected to this construction at the hearing, but in its brief, Clearwire asserts that the specification describes the dynamic changing of zone assignments by “reassign[ing] base transmitters to new zones based upon the volume of messages.” 23:45-41. Clearwire also cites to the passage “in this instance, the zonal boundaries are changed to remove this high traffic region from a zonal overlap area.” 24:21-22. Clearwire asserts that the altering of the zone boundaries improves performance. (Dkt. No. 61 at 19.) As to “regions of space,” Clearwire asserts that the specification contains multiple descriptions as to how the zone boundaries are changed. (Dkt. No. 61 at 19-20 (citing ‘403 Pat. at 24:21-22, 34:35-35:3)).

Clearwire's assertion that the specification states that zonal boundaries are redefined may be true, but the claims clearly do not recite such a limitation – in other words, the claim does not include language specifying what the result of that reassignment must be. To include the additional language sought by Clearwire would be an improper re-writing of the claim language that is on its face clear and understandable. That the specification describes an embodiment in which reassignment of the transmitters causes the zone boundaries to change does not dictate that such limitations should be added to the claim.

CONCLUSION

The Court adopts the above constructions. The parties are ordered that they may not refer, directly or indirectly, to each other's claim construction positions in the presence of the jury. Likewise, the parties are ordered to refrain from mentioning any portion of this opinion, other than the actual definitions adopted by the Court, in the presence of the jury. Any reference to claim construction proceedings is limited to informing the jury of the definitions adopted by the Court.

SIGNED this 1st day of July, 2013.

ROY S. PAYNE
UNITED STATES MAGISTRATE JUDGE

