

**IN THE UNITED STATES DISTRICT COURT  
FOR THE EASTERN DISTRICT OF TEXAS  
MARSHALL DIVISION**

IRIS CONNEX, LLC,

*Plaintiff,*

v.

DELL, INC.,

*Defendant.*

Case No. 2:15-cv-1915-JRG

---

**MEMORANDUM OPINION AND FINAL JUDGMENT**

## I. INTRODUCTION

Plaintiff Iris Connex filed suit against eighteen manufacturers of smartphones and tablets, claiming each infringed the Plaintiff's only asset, U.S. Patent No. 6,177,950, which is entitled "Multifunctional portable telephone." This type of litigation often ends before it begins. Early disposition typically results from a settlement between the parties before there is any appearance by counsel in open court. Often the first *and* last filing requiring the Court's attention is the submission of an agreed order of dismissal. This reality affords the Court limited opportunities to provide oversight as to this part of its docket. However, this case took an unexpected turn of events which made it stand out.

Early in this case, Dell filed a motion to dismiss arguing that Plaintiff Iris Connex's infringement allegations were completely implausible. As is the Court's typical practice (and unrelated to Dell's motion), this case was consolidated with the other cases serially filed by Iris Connex.<sup>1</sup> After consolidation, most of the other defendants echoed Dell's argument for dismissal. Specifically, the parties argued that the *fixed* cameras in the accused smartphones and tablets could not be considered a single "*multi-position . . . reading head*," as required by the Plaintiff's patent claims.

Through the process of conducting an early review of these motions to dismiss, the Court concluded that the entire dispute would turn on the Court's construction of a single disputed term: "multi-position . . . reading head." The Court also concluded that resolving that dispute would efficiently resolve the entire series of eighteen cases. Accordingly, the Court ordered expedited

---

<sup>1</sup> The Smith-Leahy America Invents Act requires separate suits to be filed. Multiple suits by a common plaintiff are often filed in sequence and are spoken of as being "serially filed." This Court and many of its sister courts routinely consolidate such cases for more efficient case management knowing that each case will ultimately be set for a separate trial on its own merits.

claim construction on this targeted term.<sup>2</sup> After appropriate claim construction briefing and oral argument, the Court applied established claim construction principles and determined that a “multi-position” reading head must be “physically moveable” in accordance with the patent specification. The Court then, *sua sponte*, converted the pending motions to dismiss into motions for summary judgment and allowed additional briefing. Next the Court entered summary judgment of non-infringement in favor of all Defendants and against Iris Connex. This was based on the conclusion that no reasonable juror could conclude that a fixed camera was “physically moveable” or equivalent to a physically moveable camera.

Two weeks later, Dell filed a motion for attorney fees under 35 U.S.C. § 285. Section 285 provides that the Court may, in “exceptional” cases, award attorney fees to the prevailing party. Dell argued that Iris Connex’s claim construction position was unsupportable, that its infringement position was not plausible, and that its litigation was primarily settlement driven. Moreover, Dell presented evidence that strongly implied that Iris Connex was an intentionally empty shell company and, as a consequence, had no capacity to pay such fees even if the case were ultimately declared to be exceptional. (Dkt. No. 25.)

The Court, having been presented with a *prima facie* showing of entitlement to attorney fees and objective indicia of Plaintiff’s shell corporation status, ordered further discovery into the extended identity of Iris Connex. Ordinarily, the Court does not scrutinize litigants’ business decisions or their chosen structures. Courts and litigants often have limited resources, and such scrutiny often fails to further the interests of judicial economy. However, the Court is mindful of

---

<sup>2</sup> This is typically referred to as a “mini-*Markman*” and can be a valuable case management tool in the right circumstances.

its continuing duty to insure that statutes are carried out for their intended purpose and that ultimately justice is served. As the Court stated at a status conference held shortly after Dell filed its fees motion, “the entire thrust of Section 285 is to deter, and [the Court has] real concerns that this entity is so structured that it would effectively avoid any deterrence by the simple granting of the motion, without more.” (Dkt. No. 40 at 12:22–25.)

Given these circumstances, the Court found such post-judgment discovery to be appropriate. As the post-judgment discovery progressed, it became obvious that Iris Connex was not simply a non-practicing entity seeking to vindicate its patent rights—albeit with an exceptionally bad infringement case. Rather, as explained hereinafter, Iris Connex is the first level of two shell corporations which were intended to shield the real actor, Mr. Brian Yates, from personal liability. The Court is persuaded that Mr. Yates and those in active concert with him exploited the corporate form to operate largely in secret and to insulate the true party in interest from the risk associated with dubious infringement suits—that risk being fee shifting under Section 285.

Turning a blind eye to this type of conduct would run counter to the Court’s larger duty to “do justice” and countenance an accelerating misuse of our judicial system, which occurs when the resolution of dubious or nonsensical claims stands in the way of resolving bona fide disputes between ordinary litigants.

## **II. BACKGROUND**

The Court believes an overview of the various parties, their relationships, and the facts of the case is helpful at this juncture. Unless otherwise stated, the following section constitutes specific findings of fact by the Court:

**A. The Parties**

**a. Iris Connex, LLC**

Iris Connex, LLC (“Iris Connex”) is a Texas limited liability company with its stated principal office at 211 East Tyler Street, Suite 600-A, Longview, Texas. (Dkt. No. 1 at ¶ 3) (“Suite 600-A”). Iris Connex purports to own by assignment United States Patent No. 6,177,950 (“the ’950 patent”) entitled “Multifunctional portable telephone,” (Dkt. No. 1 at ¶ 9), and it holds the ’950 patent as its only asset. Iris Connex is wholly owned by Q Patents, Inc. (Dkt. No. 33.)

**b. Mr. Nicolas Labbit**

Mr. Labbit is a 31-year-old Texas lawyer residing in Longview, Texas. He became licensed to practice law in 2012. He is the designated Manager of Iris Connex as shown by the Texas Secretary of State’s Office.

**c. Q Patents, Inc.**

Q Patents, Inc. (“Q Patents”) is a California corporation located at 35 Hugus Alley, Suite 210, Pasadena, California 91103. (Yates at 48:13–22.)<sup>3</sup> Q Patents is the sole member, 100 percent owner, and corporate parent of Iris Connex. Q Patents is a holding company for other patent assertion entities. (Yates at 24:12–15.) The President and sole shareholder of Q Patents is Mr. Brian L. Yates.

---

<sup>3</sup> Citations to the November 1, 2016 deposition of Mr. Brian Yates (Dkt. No. 97-1) are cited as “Yates,” and citations to the November 2, 2016 depositions of Mr. Nicolas Labbit (Dkt. No. 97-2) and Mr. Charles Tadlock (Dkt. No. 97-8) are cited similarly. Citations to the declarations of Mr. Brian Yates (Dkt. No. 128) are cited as “Yates Decl.” and citations to the declarations of Mr. Nicolas Labbit (Dkt. No. 129) and Mr. Charles Tadlock (Dkt. No. 122) are cited similarly. Citations to the January 12, 2017 hearing transcript (Dkt. No. 141) are cited as “Hearing.”

**d. Mr. Brian Yates**

Mr. Yates is a California lawyer residing in Pasadena, California. He actively practiced in the area of intellectual property law for over 20 years. He is President and sole shareholder of Q Patents. (Yates at 10:6–8, 70:11–14.)

**e. Mr. Charles Tadlock and the Tadlock Law Firm**

Charles Craig Tadlock, a Texas lawyer, is the Managing Partner of the Tadlock Law Firm based in Plano, Texas. Mr. Tadlock is an established trial lawyer with over 20 years of experience. From the beginning of this suit until November 28, 2016, Mr. Tadlock and the Tadlock Law Firm represented Iris Connex against Dell.

**f. Original Defendants**

Defendants are manufacturers of consumer electronics, including smartphones and/or tablets with two or more fixed cameras. Of the eighteen original Defendants to this lawsuit, only Dell, Inc. (“Dell”) remains before the Court. Pursuant to joint stipulations with Iris Connex, former Defendants Acer America Corp.; Alcatel-Lucent USA, Inc.; Apple Inc.; Asus Computer International; Blackberry Corporation; Fujitsu America, Inc.; Hewlett-Packard Company; HTC America, Inc.; Huawei Device USA Inc.; Lenovo (United States) Inc. and Motorola Mobility LLC; LG Electronics U.S.A., Inc.; Microsoft Corporation; Panasonic Corporation of North America; Samsung Electronics America, Inc.; Sharp Electronics Corporation; Sony Mobile Communications (USA), Inc.; and Toshiba America Information Systems, Inc. have each been dismissed with prejudice. As a part thereof, they have each agreed to forego all claims against Iris Connex for attorney fees, expenses, sanctions, and costs. Many of these Defendants were affirmatively compensated by Mr. Yates to secure such dismissals after the entry of summary judgment, but before formally asserting their own Section 285 motions. Such compensation from

Mr. Yates (or entities controlled by Mr. Yates) included some or all of the following: direct cash payments, free licenses to the patent-in-suit, free licenses to unrelated patents held by other entities controlled by Mr. Yates, and covenants not to sue. (*See* Dkt. No. 130-1 (Summary of Iris Connex LLC Settlement Agreements).)

**B. U.S. Patent No. 6,177,950**

Iris Connex allegedly acquired the '950 patent by assignment on November 11, 2015 from AVT Audio Visual Telecommunications (“AVT”). (*Id.*) The '950 patent relates to a personal communication device that includes a number of elements. Figure 1A of the '950 patent illustrates an exemplary embodiment of the “Multiphone.”

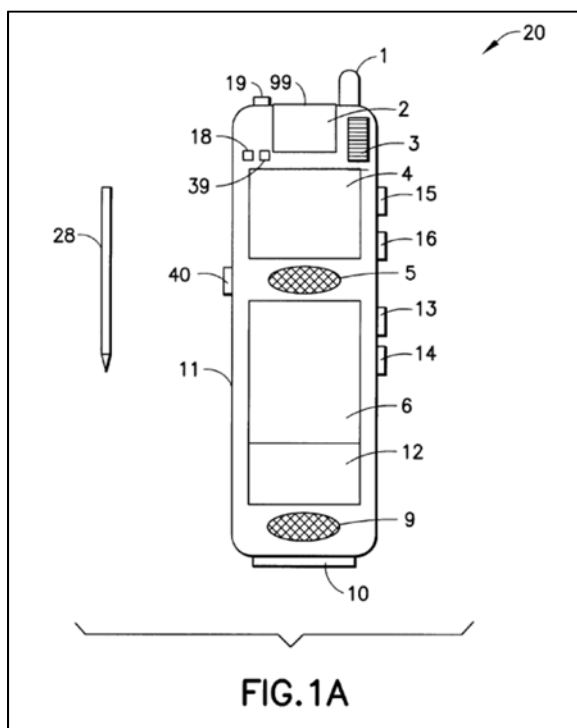

In this lawsuit, Iris Connex asserted Claim 1 and claims depending from Claim 1 to establish infringement by making, using, selling, or offering for sale various smartphones and tablets containing a front-facing and rear-facing camera. Claim 1 of the '950 patent reads:

A personal communication device, comprising:  
a display for displaying data and video signals;  
a loudspeaker for generating an audible signal;  
a microphone for receiving an audio signal;  
a keypad for entering data;  
a telecommunications interface for receiving and transmitting information; and  
an internal multi-position and multi-function reading head for producing an image signal  
when in a first position using a first lensing and for reading for image conversion using  
a second lensing when in a second position.

(Dkt. No. 1-1 at 23) (emphasis added).

### **C. Litigation History**

#### **a. Iris Connex's Complaint**

On November 30, 2015, Iris Connex filed its Complaint against Dell and concurrently filed serial actions against other manufacturers of smartphones and tablets containing fixed rear-facing and fixed front-facing cameras. These cases collectively reflect a single effort by Iris Connex to recover from multiple Defendants regarding their alleged infringement of the '950 patent "by making, using, selling, or offering for sale various smartphones and tablets containing a front-facing and rear-facing camera."

By letter dated January 20, 2016, Dell's attorneys notified Iris Connex and its counsel of the implausibility of these allegations and urged Iris Connex to withdraw its Complaint. (Dkt. No. 97-10.) Dell pointed out that its tablets simply do not have a camera with the essential claim elements of the '950 Patent and that Iris Connex did not have a reasonable basis for maintaining this suit. (*Id.*) Iris Connex continued to act as though such letter had never been sent. In fact, on March 2, 2016, Iris Connex offered Dell a settlement and non-exclusive license to the '950 Patent for a one-time lump-sum of \$80,000. (Dkt. No. 122-10.)

On March 8, 2016, Dell filed a motion to dismiss under Federal Rule of Civil Procedure 12(b)(6) stating that Iris Connex's allegations were implausible. Specifically, Dell argued that



the two fixed-cameras in its products—“tablets with a front-facing camera and a rear-facing camera”—could not plausibly infringe a claim directed to a personal communication device having a “multi-position and multi-function reading head with first and second positions” as claimed in the ’950 Patent. Dell argued that the plain language of the claim limitation required that at least one reading head be capable of being oriented into “a first position” and “a second position,” thereby excluding its products which had only fixed, non-moveable cameras. On March 23, 2016, as it often does for case management purposes, the Court consolidated this case with the cases which had been serially filed against the other Defendants. Between April 4, 2016 and April 25, 2016, most of the Defendants filed similar motions to dismiss, each urging dismissal of the Complaint on the same grounds.

On April 15, 2016, Iris Connex served its infringement contentions on Defendants. In response, Dell sent a letter to counsel for Iris Connex alleging that it intended to seek sanctions under Rule 11 for what it believed to be an objectively baseless lawsuit. Dell stated that if Iris Connex did not dismiss its Complaint by May 9, 2016 it would seek Rule 11 sanctions against Iris Connex and its counsel.

The Court, by conducting an early review of these motions to dismiss, became aware that each turned on the construction of the last element of Claim 1 of the ’950 patent. Accordingly, on May 25, 2016, the Court *sua sponte* entered an Order setting an early and targeted claim construction in this case on July 20, 2016 which was limited to the disputed critical term. *Iris Connex v. Acer, et al.*, Case No. 2:15-cv-1909, Dkt. No. 176 (E.D. Tex.) (“Acer Case”); *see also Wordcheck Tech, LLC v. Alt-N Techs., Ltd.*, 2012 WL 975725, at \*2 (E.D. Tex. Jan. 11, 2012) (opining that a “mini-*Markman*” is appropriate early in a case where “construction of a very narrow set of terms could resolve the case as to most, if not all, parties.”); *Uniloc USA, Inc. v. Imagine*

*Corp.*, LLC, 2013 WL 3871360, at \*5 (E.D. Tex. July 24, 2013) (“The Court utilizes the mini-*Markman* proceeding to address terms that, if construed, are case dispositive.”).

During the resulting briefing, the parties submitted various outside materials which went beyond the pleadings. The Court deemed these materials to be probative and relevant to the issues before the Court. Therefore, pursuant to Federal Rule of Civil Procedure 12(d), the Court converted the then-pending motions to dismiss into motions for summary judgment under Rule 56, *see Trinity Marine Prods., Inc. v. United States*, 812 F.3d 481, 487 (5th Cir. 2016), and gave notice to the parties of the same at the claim construction hearing. (*See* Dkt. No. 231 at 71:6–22.) The Court instructed the parties to submit the relevant materials accompanied by a brief of up to ten pages. (*See id.* at 72:7–22; Dkt. No. 229.) The Court later allowed the parties to file responses to address issues raised by the opposing parties. (*See* Dkt. No. 238.)

**b. Summary Judgment of Non-Infringement**

On September 2, 2016, the Court construed the claims of the ’950 patent and granted summary judgment of non-infringement against Iris Connex and in favor of each Defendant. (Dkt. No. 21) (the “Summary Judgment Order”). As the Court stated, the “cases demonstrate, [that] early claim construction on a limited set of disputed terms followed by entry of summary judgment is appropriate if a superficial understanding of the accused products makes it clear that a single limitation is obviously absent from the accused products and that full blown discovery could not lead a reasonable jury to any other conclusion.” (Summary Judgment Order at 39.)

Such was the case here. Regarding claim construction, the Court construed the disputed phrase “an internal multi-position and multi-function reading head” to mean “a single internal multi-function reading head that is physically moveable.” Then, having determined that the asserted claims all required “a single internal multi-function reading head that is physically

moveable where the reading head has a single sensor,” the Court turned to the question of summary judgment, *i.e.*, whether a reasonable jury could find that the Accused Products contained such, either literally or through the doctrine of equivalents. “There can be no infringement as a matter of law if a claim limitation is totally missing from the accused device.” *London v. Carson Pirie Scott & Co.*, 946 F.2d 1534, 1538 (Fed. Cir. 1991). It was clear from the parties’ submissions that each camera in the accused devices was fixed. Further, the Court held that Iris Connex’s doctrine of equivalents argument failed for two independent reasons: (1) the argument was unavailable as a matter of law due to prosecution history estoppel and (2) the alleged equivalent structure in the accused device, a multi-camera/software-toggling system, was the “fundamental opposite” of the claimed single multi-function and multi-positional reading head. As a result, the Court concluded that neither infringement position had any merit. The Court then entered summary judgment in favor of all Defendants.

**c. Dell’s Motion To Declare This Case Exceptional**

On September 16, 2016, Dell filed its Motion to Find the Case Exceptional and Award Fees seeking attorney fees and sanctions from Iris Connex and its counsel pursuant to 35 U.S.C. § 285, 28 U.S.C. § 1927, Federal Rule of Civil Procedure 11, and the Court’s inherent authority. (Dkt. No. 25, “Dell’s Section 285 Motion”.) Dell argues that fees and sanctions are appropriate against Iris Connex and its counsel because, in spite of being placed on notice, Iris Connex persisted in prosecuting an objectively unreasonable case. (*Id.* at 7–8.) Dell further argues that Iris Connex’s real purpose in filing this litigation was to procure settlements, in amounts less than the defense costs that Dell and other Defendants would incur over a period of only a few months. (*Id.* at 8.)

In light of serious allegations raised in Dell's Section 285 Motion as to Iris Connex's true identity, the Court ordered a telephonic status conference. (*See* Dkt. No. 40.) As a result, the Court ordered that Dell conduct targeted post-judgment discovery concerning the extended identity of Iris Connex to identify the ultimate party at interest acting as the Plaintiff. At the conclusion of this telephonic conference, the parties were instructed to meet-and-confer and then submit by October 7, 2016 a jointly proposed discovery order for the Court to consider in this regard.

The Court now pauses its narrative to emphasize that such post-judgment discovery is rare, but justified by the facts of this case. The Court did not order this discovery because Iris Connex is a non-practicing entity. Dell's Motion also asserted that Mr. Labbit, the manager of Iris Connex and a recently minted lawyer, was "the only person identified or associated with Iris Connex" and managed many other non-practicing entities from the same office as Iris Connex. (Dkt. No. 25 at 2-3.) Also, Iris Connex, which was formed less than two months before filing this suit, did not disclose a corporate parent in its Rule 7.1 corporate disclosure statement, (Dkt. No. 3), and it did not disclose in its initial disclosures any person or entity directly associated with Iris Connex other than Mr. Labbit. (Dkt. No. 17-11.) Those disclosures required Iris Connex to identify all persons "having knowledge of relevant facts, a brief statement of each identified person's connection with the case, and a brief, fair summary of the substance of the information known by any such person." (*Id.*; Acer Case, Dkt. No. 136). In fact, the only such persons disclosed by Plaintiff were Mr. Labbit, the inventor Mr. Garry Robb, and the two prosecuting attorneys for the patent-in-suit. Simply put, it appeared to the Court that there must be a real but hidden party in interest. These troubling allegations supported the unusual step of ordering targeted post-judgment discovery in this case.

**d. Iris Connex And Its Undisclosed Corporate Parent File For Bankruptcy In California**

What unfolded shortly after the Court ordered post-judgment discovery quickly confirmed the Court's concerns. On October 6, 2016, Q Patents filed a petition for bankruptcy under Chapter 11 in the Central District of California. (*See* Dkt. No. 1, 2:16-bk-23244 (C.D. Cal.)) Then, just twenty-five minutes after Q Patents filed for bankruptcy, Iris Connex filed for Chapter 11 bankruptcy in the same district, declaring that a bankruptcy case concerning its affiliate, general partner, or partnership was pending in that District. As a part thereof and for the first time, Iris Connex represented that it was a wholly owned subsidiary of Q Patents. (*See* Dkt. No. 1, 2:16-bk-23249 (C.D. Cal.)) After the close of business on October 6, 2016, Iris Connex filed a supplemental Rule 7.1 Disclosure in this Court, changing by 180 degrees its previous representation that it did not have a parent corporation. The supplemental disclosure provided that "all of the membership interests in Iris Connex are held by Q Patents, Inc., a California corporation." *Compare* Dkt. No. 3 (September 2, 2015 Corporate Disclosure Statement):

**PLAINTIFF IRIS CONNEX SOLUTIONS, LLC'S  
RULE 7.1 DISCLOSURE STATEMENT**

Pursuant to Fed.R.Civ.P. 7.1, Plaintiff Iris Connex, LLC states that it does not have a parent corporation and that there is no publicly held corporation owning ten percent or more of its membership interests.

Dated: December 2, 2015

Respectfully submitted,

*with* Dkt No. 33 (October 6, 2016 Corporate Disclosure Statement):

**PLAINTIFF IRIS CONNEX, LLC'S SUPPLEMENTAL  
RULE 7.1 CORPORATE DISCLOSURE STATEMENT**

Plaintiff Iris Connex, LLC ("Iris Connex"), hereby supplements its Corporate Disclosure Statement pursuant to Fed. R. Civ. P. 7.1, to state that all of the membership interests in Iris Connex are held by Q Patents, Inc., a California corporation. No publicly held corporation owns ten percent or more of Iris Connex's membership interests.

Dated: October 6, 2016

Respectfully submitted,

Rather than meet-and-confer with Dell concerning a schedule for the targeted discovery as ordered, Iris Connex ran to the bankruptcy court in California and immediately served this Court with a notice entitled "Suggestion of Bankruptcy" asserting that pursuant to 11 U.S.C. § 362(a), all proceedings against Iris Connex (including the post-judgment discovery ordered only days before by this Court) were automatically stayed. This Court disagreed. (Dkt. No. 36.) Having considered the applicable statute and relevant authorities, the Court concluded that its pending matters were not proceedings "against the debtor" as contemplated by the statute. 11 U.S.C. § 362(a). Perhaps more importantly, the Court retains jurisdiction to police misconduct before the Court under 11 U.S.C. § 362(b)(4). The Court also recognized that it has the inherent authority to protect the integrity of the judicial process. It was apparent that "Iris Connex's only stated justification for seeking bankruptcy protection was entirely contingent on the outcome of the very proceedings it sought to stay." (Dkt. No. 36 at 8.) The Court ordered Dell to proceed with the post-judgment discovery it had specified.

One week later, Iris Connex filed a motion seeking a 45-day stay to allow it to obtain substitute counsel. According to Iris Connex, under the agreement for legal services, the Tadlock

Law Firm did not agree to handle fee-shifting motions. Further, the motion mistakenly asserted (with no cited legal authority) that continued representation of Iris Connex by the Tadlock Law Firm in this matter required approval of the Bankruptcy Court in California. This motion was denied. (Dkt. No. 48.) Next, Iris Connex filed a Motion to Withdraw the Tadlock Firm as its counsel. Such motion did not name or propose substitute counsel, which would have effectively left Iris Connex in a *pro se* posture. This too was denied. (*Id.*) Then, Iris Connex filed an “emergency motion” for a protective order to prevent Dell from taking the depositions of Mr. Yates, Mr. Tadlock, and Mr. Labbit until Iris Connex obtained substitute counsel free of conflicts. (Dkt. No. 46 at 1.) This also was denied. (Dkt. No. 48.)

On October 26, 2016, the day after the Court denied all three of these late-breaking motions, Iris Connex moved to dismiss its California bankruptcy case. Interestingly, this Motion noted that neither Iris Connex nor Q Patents would be filing their respective Schedules of Assets and Liabilities or their Statements of Financial Affairs with the Bankruptcy Court—even though those items were then past due. The Bankruptcy Court dismissed the Chapter 11 case on October 27, 2016.

**e. Post-Discovery Motions**

On November 28, 2016, Dell notified the Court that it had completed discovery concerning the extended identity of Iris Connex, and it requested leave to supplement its Section 285 Motion. (Dkt. No. 59.) Dell also sought relief from the extensive confidentiality designations and privilege assertions made by deponents Brian Yates, Nicolas Labbit, and Craig Tadlock during such discovery. (Dkt. No. 60.)

On December 6, 2016, the Court lifted its earlier stay in the consolidated member cases and granted Dell leave to supplement its initial brief. (Dkt. No. 74.) Lifting the stay opened the way for the other Defendants to join Dell in seeking fee-shifting under Section 285. The Court had earlier stayed these separate but similarly situated Defendants to insure there would be no duplication of effort or compounding of expenses in the post-judgment discovery process. In addition, the Court prescribed a briefing schedule for all parties but ordered that all additional briefing be submitted under seal pending the Court's consideration of Dell's Motion for Relief From Confidentiality. (Dkt. No. 74.)<sup>4</sup> Importantly, the Court (pursuant to Federal Rule of Civil Procedure 19 and the Court's inherent power) formally joined Q Patents, Mr. Yates, Mr. Labbit, and Mr. Tadlock as parties to this case to insure each a full opportunity to respond, to contest liability for any sanction or fee award, and to otherwise receive due process. (*Id.* at 1–2.)

**D. The Court's Hearing**

On January 12, 2017, the Court held a hearing on these post-judgment matters. All parties appeared by counsel and Messrs. Yates, Labbit, and Tadlock appeared in person. Each of these three presented live testimony. The post-judgment discovery and such hearing established the following additional facts:

1. Iris Connex was formed and authorized to do business as a Texas limited liability company on October 13, 2015. (Dkt. No. 97-4 at 9.)
2. Iris Connex has no assets except for the '950 patent and it holds no working capital. (Yates 25:11–19, 55:2–7.)
3. Iris Connex has no employees. (Yates 29:5–7.)

---

<sup>4</sup> The Court's Order concerning such motion will be entered contemporaneously with this Memorandum Opinion and Final Judgment.



4. Iris Connex was formed for the sole purpose of enforcing its lone asset. (Yates 60:7–8.)
5. The regulations governing Iris Connex called for a \$1,000 capital contribution from Q Patents as well as a \$100,000 line of credit from Q Patents for the benefit of Iris Connex. Q Patents is the sole obligor on the line of credit. The initial \$1,000 capital contribution from Q Patents was used to pay for the formation of Iris Connex with the Texas Secretary of State. (*See* Dkt. No. 129-2.) (Iris Connex’s Regulations)
6. Iris Connex paid no cash value for the ’950 patent. (Dkt. No. 128-2 at 4.) AVT, the assignor, reserved a right to 50 percent of all the profits realized by monetizing the ’950 patent. AVT also retained a right to reacquire the ’950 patent, unless Iris Connex produced and paid at least \$500,000 under the terms of the agreement to AVT within 24 months of the assignment. (*See id.*; Yates at 15:1–9.)
7. Iris Connex did not have a bank account until April 2016, seven months after its formation and more than five months after filing this lawsuit. (Labbit at 54:2–13.) Once a bank account was finally opened in the name of Iris Connex, its total cash balance consisted of \$100.00 deposited from Mr. Labbit’s personal funds. (Labbit at 55:19-56:1.)
8. Iris Connex pays no rent, (Labbit at 22:22–23:10), and shares its office with 15 to 20 other entities owned directly or indirectly by Brian Yates. (Labbit at 12:3–8.) Iris Connex has no furniture or other physical assets at this location. (Labbit at 26:7–15.) There is no sign for Suite 600-A displayed on any door in the building identifying Iris Connex as an occupant. (*See* Dkt. No. 17-2.)
9. Q Patents pays the debts of Iris Connex, including the expenses associated with forming Iris Connex and its litigation fees, under a line of credit. (Yates at 51:22–56:7; Labbit at 84:14–17.) Q Patents ultimately paid the Tadlock Law Firm to represent Iris Connex in this litigation. (Yates at 52:2–9.)
10. Mr. Tadlock did not know about Q Patents when he filed the original Rule 7.1 disclosure. (Hearing at 46:5–7.) Mr. Labbit did. (Hearing at 60:4–6.)
11. At present, Q Patents is a holding company for four currently operating patent assertion entities, two of which are managed by Mr. Labbit and two of which are managed by Lloyd Kraus, another attorney in Tyler, Texas. (*See* Yates at 26:8–27:9.) The assets of the other subsidiary companies held by Q Patents are “fairly fluid.” (Yates at 154:4–11.)
12. Q Patents had, as of November 1, 2016, less than \$10,000 in its bank account. (Yates 24:25–25:10.)
13. All of Iris Connex’s net profits and losses for any fiscal year are wholly allocated to Q Patents. (Dkt. No. 97-4 at 25.)

14. When Q Patents has insufficient cash on hand to pay its obligations, or those of Iris Connex, Mr. Brian Yates injects his own money into the company or pays their bills directly. (Yates at 59:17–61:8.)
15. Entities owned directly or indirectly by Mr. Yates, many of which show Mr. Labbit as the Manager and which share the same mailing address as Iris Connex, have filed multiple patent infringement lawsuits in Eastern District of Texas. These entities have also failed to disclose their corporate parent pursuant to Federal Rule of Civil Procedure 7.1 (Yates at 97:17–98:15; *e.g.*, *id.* at 102:8–18; *id.* at 104:9–18.)
16. None of the lawsuits brought by the entities owned directly or indirectly by Mr. Yates have ever gone to trial. (Yates at 94:1–7.) When the lawsuits are over, the patent assertion companies dissolve. (Yates at 31:22–32:12.)
17. Mr. Labbit receives no salary from Iris Connex. He receives a salary from Spectrum Patents, Inc., another Yates-owned holding company for patent assertion entities. (Yates 27:14–28:15.) Mr. Labbit is entitled to receive 10 percent of any net profits from Iris Connex. (Yates at 27:17–22.)
18. Mr. Labbit generally works from home and only occasionally visits Suite 600-A to pick up the mail. (Labbit at 10:11–11:2.)
19. Mr. Labbit was admitted to practice law in Texas in 2012. Currently he works only for Mr. Yates, Q Patents, and Spectrum Patents. (Labbit at 18:20–24.)
20. Mr. Tadlock has represented at least a dozen patent enforcement entities owned directly or indirectly by Mr. Yates. (Tadlock at 47:4–15.)
21. Neither Mr. Yates nor Mr. Tadlock has ever visited the office of Iris Connex in Longview, Texas. (Yates at 34:11–18; Tadlock at 35:21–22; Labbit at 19:17–20.)
22. The engagement letter between Iris Connex and the Tadlock Law Firm, (Dkt. No. 97-9) (“Tadlock Engagement Agreement”), dated October 13, 2015, contemplates claims under Rule 11. (*Id.* at 5.) It also provides, among other things, that:
  - a. No later than the execution of the engagement agreement, Iris Connex would provide the Tadlock Firm with information and materials concerning the identity of all entities or individuals with a pecuniary interest in the case, and draft and provide infringement charts evidencing a reasonable, good faith belief that Defendants infringe the ’950 patent. (*Id.* at 4, 8–9.) This did not happen.
  - b. No later than the execution of the engagement agreement, Iris Connex would provide the Tadlock Law Firm with documents sufficient to evidence Iris Connex’s ownership of the ’950 patent. (*Id.* at 8.) Iris Connex did not own the ’950 patent at that time. The assignment agreement between AVT and Iris Connex was executed on November 11, 2016.

- c. No later than the execution of the engagement agreement, Iris pledged to provide the Tadlock Law Firm with, among other things, the complete prosecution history for the '950 patent. (*Id.*) That did not happen.
  - d. Iris Connex agreed to pay the Tadlock Law Firm a contingency fee as compensation for its representation. (Dkt. No. 97-9 at 5.)
23. Both Mr. Labbit and Mr. Yates performed pre-suit diligence and established the infringement theories in this case. (Yates at 34:5–10; Yates Decl. at ¶ 45, 71.) Mr. Yates was responsible for diligence prior to acquisition and both Mr. Yates and Mr. Labbit examined the prosecution history and the accused products before filing this lawsuit. (Yates at 131:23–132:11; Yates Decl. at ¶ 45, 71.) Mr. Yates reviewed and approved the decision to sue Dell. (Yates at 134:15–17.)
24. Mr. Yates was responsible for approving all settlements and license agreements on behalf of Iris Connex. (Yates Decl. at ¶ 45, 72–80; Hearing at 65:10–68:15.) He oversaw Iris Connex’s financial operations and decision making. (Yates Decl. at ¶ 45.)

### **III. EXCEPTIONAL CASE FEES**

The Court first turns to the issue of whether this case is exceptional under Section 285 and who might be properly liable.

#### **A. Legal Standard**

##### **a. Exceptionality**

“District courts may determine whether a case is ‘exceptional’ in the case-by-case exercise of their discretion, considering the totality of the circumstances.” *Octane Fitness, LLC v. ICON Health and Fitness, Inc.*, 134 S. Ct. 1749, 1756 (2014); *see also Highmark Inc. v. Allcare Health Mgmt. Sys., Inc.*, 134 S. Ct. 1744, 1748 (2014) (“[T]he determination whether a case is ‘exceptional’ under § 285 is a matter of discretion.”). Section 285 imposes “one and only one constraint” on a district court’s discretion to award attorney fees in patent litigation: the case must be “exceptional.” *Octane Fitness*, 134 S. Ct. at 1755–56. The movant must show exceptionality by a preponderance of the evidence. *Site Update Sols., LLC v. CBS Corp.*, 639 Fed. App’x 634, 637 (Fed. Cir. 2016).

The standard for determining whether a case is exceptional has been well explored. An exceptional case “is simply one that stands out from others with respect to the substantive strength of a party’s litigating position (considering both the governing law and the facts of the case) or the unreasonable manner in which the case was litigated.” *Octane Fitness*, 134 S. Ct. at 1756. The Supreme Court further opined that a district court may consider a “nonexclusive” list of “factors,” including “frivolousness, motivation, objective unreasonableness (both in the factual and legal components of the case) and the need in particular circumstances to advance considerations of compensation and deterrence.” *Id.* at 1756 n.6. *Octane Fitness* gives this Court wide discretion to consider the totality of the circumstances in determining whether and to what extent to award attorney fees under Section 285. In assessing a party’s subjective state of mind, the Court also considers the totality of the circumstances. *See Kilopass Tech., Inc. v. Sidense Corp.*, 738 F.3d 1302, 1310 (Fed. Cir. 2013).

The issue concerning the amount to be awarded has also been well explored. That too lies within the sound discretion of this Court. *See Lumen View Tech. LLC v. Findthebest.com, Inc.*, 811 F.3d 479, 483 (Fed. Cir. 2016); *Monolithic Power Sys., Inc. v. O2 Micro Int’l Ltd.*, 726 F.3d 1359, 1365 (Fed. Cir. 2013). *See also Highmark*, 134 S. Ct. at 1749.

**b. Who Can Be Liable**

The question of who can be held liable under Section 285 has not been exhaustively explored by the appellate courts. However, this Court does not have the luxury of waiting for further guidance. As explained below, the Court concludes that the statutory text, current case law, and statutory purpose behind the Patent Act and Section 285 all support assessing direct Section 285 liability against non-parties, so long as (1) the actor is responsible for conduct that makes the case exceptional, (2) the actor is afforded due process, and (3) it is equitable to do so.

**i. The Text**

The Court starts with the text: “The court in exceptional cases may award reasonable attorney fees to the prevailing party.” 35 U.S.C. § 285. The statute imposes only one constraint on district courts’ discretion to award attorney fees—the case must be exceptional. It is silent on the question of who should pay. Nothing in the text limits liability to a named party in the suit. Congress could have specified otherwise, but it did not.

**ii. The Case Law**

Admittedly, the current case law interpreting Section 285 in this regard is limited. Nevertheless, as capably explained in a recent law review article, the few cases that have confronted this question have all recognized the district court’s authority to award fees against a non-party, “even if the person was not an original party to the action, but rather joined in his or her sole capacity as a third party defendant.” Daniel Kennedy, *Holding Parent Corporations Liable for Attorneys’ Fees Under 35 U.S.C. § 285 of the Patent Statute*, 61 Baylor L. Rev. 999, 1010 (2009).

In *Ohio Cellular Products Corp. v. Adams USA, Inc.*, 175 F.3d 1343, 1349 (Fed. Cir. 1999), the Federal Circuit upheld an award under Section 285 against someone other than an original plaintiff. There, the defendants sought leave after the entry of judgment to amend their pleading to add Donald Nelson, co-inventor of the patent-in-suit and sole shareholder of the plaintiff, in his individual capacity as a third-party defendant, specifically because “they feared that they would be unable to collect most or all of the fee award if only Ohio Cellular remained liable.” *Id.* at 1346. The district court found that Nelson was intimately involved in the prosecution of the patent-in-suit and that it was his conduct that formed the basis for concluding that the case was

exceptional. Under such circumstances, the Federal Circuit perceived no error in holding Nelson individually liable under Section 285.<sup>5</sup>

*Ohio Cellular* does not stand alone. Other Federal Circuit cases have upheld similar results. *See also Mach. Corp. of Am. v. Gullfiber AB*, 774 F.2d 467, 475 (Fed. Cir. 1985) (opining that the Court may assess fees under Section 285 against the agent of a disclosed principal, even if he is a non-party to the patent claims, when that agent is responsible for the predicate acts rendering the case exceptional). A district court in the Southern District of New York recognized this line of authority in holding an individual who served as president, CEO, and major stockholder of the patentee jointly liable under Section 285. *D.O.C.C. Inc. v. Spintech Inc.*, 1994 WL 872025, at \*20 (S.D.N.Y. Aug. 15, 1994). More recently, another court within that district came to the same legal conclusion, even though it ultimately found that there was insufficient evidence to support imposing an award beyond the originally named party. *Gust, Inc. v. AlphaCap Ventures, LLC*, 2016 WL 7165983, at \*10 (S.D.N.Y. Dec. 8, 2016).

These cases all recognize a more general and uncontroversial principle: that the corporate form cannot be used as a shield to insulate officers and parent corporations against liability for their own tortious conduct or tortious conduct they control. *Cf. United States v. Bestfoods*, 524 U.S. 51, 64 (1998) (stating that a corporate parent that actively participated in, and exercised control over, the operations of a facility may be held directly liable in its own right as an operator of the facility under CERCLA). Patent law holds no exception to this general principle. Thus,

---

<sup>5</sup> The Supreme Court reversed *Ohio Cellular* in *Nelson v. Adams USA, Inc.*, 529 U.S. 460, 466 (2000), holding that simultaneously amending the judgment with amendment of pleadings to impose liability on Nelson violated due process. However, the substantive holding remained intact. The due process concern raised in *Nelson* does not apply here. This Court acted on its own to join Messrs. Yates, Labbit, Tadlock, and Q Patents to insure their individual receipt of due process.

in the context of infringement, the Federal Circuit has held that corporate officers remain individually liable if they personally took part in the commission of the tortious act. *See Orthokinetics, Inc. v. Safety Travel Chairs, Inc.*, 806 F.2d 1565, 1579 (Fed. Cir. 1986). More recently, the Federal Circuit has held that a parent corporation cannot circumvent liability for direct patent infringement by outsourcing performance of a step of the claim, if it directs or controls the performance of that step. *Akamai Techs., Inc. v. Limelight Networks, Inc.*, 797 F.3d 1020 (Fed. Cir. 2015). The Court sees no compelling reason to deviate from these cases and generally established legal principles. Indeed, to do so would be error.

### **iii. Intent of Section 285**

Next, the Court turns to the intent and purposes behind Section 285.

Statutory fee shifting is an exception to the “American Rule” in which the prevailing litigant is not entitled to attorney fees. The American Rule is rooted in the idea that litigants should not be penalized for defending or prosecuting lawsuits and to do so would chill the public’s access to justice. *See Fleischmann Distilling Corp. v. Maier Brewing Co.*, 386 U.S. 714, 718 (1967).

Congress first made fee shifting available in patent cases during the Truman Administration. The relevant shifting provision provided that “[t]he court may in its discretion award reasonable attorney’s fees to the prevailing party upon the entry of judgment on any patent case.” 60 Stat. 778 (codified at 35 U.S.C. § 70 (1946)). Courts went on to construe this text to allow the award of fees upon “a finding of unfairness or bad faith in the conduct of the losing party, or some other equitable consideration of similar force, which makes it grossly unjust that the winner of the particular law suit be left to bear the burden of his counsel fees which prevailing litigants normally bear.” *Mach. Corp.*, 774 F.2d at 471 (quoting *Park-in Theatres, Inc. v. Perkins*,

190 F.2d 137, 142 (9th Cir. 1951)). *See also Rohm & Haas Co. v. Crystal Chem. Co.*, 736 F.2d 688, 691 (Fed. Cir. 1984). Thus, the Court notes that fee shifting in patent cases has always focused on the equities, especially the overarching issues of fairness and substantial justice.

In 1952, Congress amended Section 70 to read as it does now: that the district court could only award fees in “exceptional” cases. The inclusion of this additional limitation codified the existing jurisprudence reflecting an intentional public policy. *See Mach. Corp.*, 774 F.2d at 471 (citing S. Rep. No. 1979, 82nd Cong., 2d Sess. (1952)). Restricting attorney fees in patent cases to exceptional cases “is based on the premise that courts should attempt to strike a balance between the interest of the patentee in protecting his statutory rights and the interest of the public in confining such rights to their legal limits.” *Id.* Nothing in the present law alters the original rationale behind fee shifting in the patent context—that an award of fees under Section 285 “should be bottomed upon a finding of unfairness or bad faith in the conduct of the losing party, or some other equitable consideration of similar force.” *Park-in Theatres*, 190 F.2d at 142.

*Fogerty v. Fantasy, Inc.*, 510 U.S. 517 (1994), a case cited by the Supreme Court in *Octane Fitness*, is also instructive. In *Fogerty*, the Supreme Court addressed the Copyright Act’s fee shifting provision. The analogous Section 505 reads that “the court may also award a reasonable attorney’s fee to the prevailing party as part of the costs.” In *Fogerty*, the Court opined that “[t]he primary objective of the Copyright Act is to encourage the production of original literary, artistic, and musical expression for the good of the public.” *Id.* at 524. The policies served by the Copyright Act are more complex than “simply maximizing the number of meritorious suits for copyright infringement.” *Id.* at 526.

The same principles articulated in *Fogerty* ring true here. Both patent law and copyright law are derived from the same constitutional mandate, “[t]o promote the Progress of Science and



useful Arts.” U.S. Const. art. I, § 8. Patent law, like copyright law, serves the specific purpose of enriching the general public, albeit through access to new and useful innovations as opposed to artistic creations. To further these aims, Congress has chosen to increase the risk borne by those who assert frivolous and exceptionally weak claims thereby incentivizing parties, like Dell, to defend against such claims. If that risk can be side-stepped by use of an empty shell to front for the real actor, simply because the real actor was not originally named as the plaintiff, then Section 285 means nothing.

An honest reading of Section 285 must be in accord with these purposes, if Section 285 is to have meaningful effect. Congress enacted Section 285 not only to deter frivolous claims and bad faith litigation (which are already covered by other statutes and rules), but also lawsuits that are simply exceptional in that they “stand out.” *Octane Fitness*, 134 S. Ct. at 1758. To be sure, exceptional cases are still, by definition, rare. *Id.* at 1756. Exceptional means exceptional. However, the threat of Section 285 looming overhead provides a check and balance meant to deter exceptional cases by imposing a direct and significant financial risk. For such a deterrent to mean something it must reach the person or entities that cause or contribute materially to the exceptional nature of the case.

However, if we assume that Section 285 permits recovery only against the originally named non-prevailing party, then the law has perversely incentivized third parties to act in ways that stand out from established litigation norms. This would foster the very type of litigation that the statute was meant to deter. *See* Dkt. No. 97 (“[H]olding Q Patents alone liable for the acts of Iris Connex would simply encourage others to create shell companies within companies, like Russian nesting dolls, to avoid Section 285 liability”). That result would be both illogical and absurd. Congress enacted Section 285 to provide incentives to defend against frivolous infringement claims because

doing so benefits the public. However, if recourse can only be had against a judgment-proof shell company, no such incentive exists. The lack of deterrence caused by empty shell plaintiffs negates the incentive to vigorously defend against meritless claims when there are no practical means by which to recover costs. *See, e.g., Raylon*, 6:09-cv-355, Dkt. No. 207 (E.D. Tex. May 4, 2015) (“On remand, Defendants abandoned their § 285 claims against Raylon because Raylon was insolvent.”). As explained herein, the Court is persuaded that *Iris Connex v. Dell* never would have been filed but for Mr. Yates’ calculated assumption that he could insulate himself personally from the possible application of Section 285.

Iris Connex argues that, both in this case and in general, the proper mechanism to recover exceptional case fees from someone like Mr. Yates is to bring a separate lawsuit to pierce the corporate veil after Section 285 fees have been separately awarded. (Hearing at 86:13–87:1.) The Court disagrees. First, while this approach may be used, it is not the only path. One acceptable way to recover fees does not preclude another. Further, any requirement that a second lawsuit must be filed to reach the real actor runs counter to the congressional intent and the clear purpose behind Section 285.

The Court rejects this narrow view of its authority to award fees under Section 285. Such would frustrate the balancing of risk and reward which Congress intended. Ultimately, the interposing of an “Iris Connex” between the real actor and an exceptional case fails to deter frivolous lawsuits. Even worse, it would actually encourage them.

## **B. Analysis**

With these principles in mind, the Court now turns to their application to this case.

a. **This Case is Exceptional**

i. **Iris Connex’s Arguments Were Unsupportable**

Dell argues that “review of the ’950 Patent, its file history, and the Dell tablet products shows that Plaintiff did not develop an objectively reasonable theory of infringement before filing the Complaint.” (Dkt. No. 25 at 13.) On this point, the Court agrees with Dell, and it is the Court’s primary—but not only—basis for finding this case exceptional.

1. **An Unsound Claim Construction**

With regard to the sole disputed term, “multi-function and multi-position reading head,” Iris Connex’s proposed claim construction was not only implausible but nonsensical:

<b>Disputed Terms</b>	<b>Iris Connex’s Proposed Construction</b>
an internal multi-position and multi-function reading head	an internal multi-position and multi-function reading head with at least two lensings, wherein  such reading head may comprise one or more cameras, and wherein  ‘camera’ should be read within the context of ‘an internal multi-positon and multi-function camera’ and otherwise has its plain and ordinary meaning within the context in which it is used, and which is not limited to merely the lens(es) nor to merely the lens(es) and image sensor

For reasons explained in the Summary Judgment Order, Iris Connex’s proposed construction contravened well-established law by (1) adding words and limitations to the claim language without support in the intrinsic evidence; (2) construing the claims in light of the accused device, not the specification; and (3) relying on extrinsic evidence to the exclusion of the intrinsic

evidence. (Summary Judgment Order at 25–32.) Adopting Iris Connex’s construction would have required the Court to disregard these accepted tenets of claim construction.

The purpose underlying the claim construction process is for the Court to interpret the claims and thereby aid the jury in determining infringement and invalidity. *See Embrex, Inc., v. Serv. Eng’g Corp.*, 216 F.3d 1343, 1347 (Fed. Cir. 2000) (“The construction of claims is simply a way of elaborating the normally terse claim language in order to understand and explain, but not to change, the scope of the claims.”); *Paradox Sec. Sys. Ltd. v. ADT Sec. Servs., Inc.*, 710 F. Supp. 2d 590, 608 (E.D. Tex. 2008). Not only was Iris Connex’s proposed construction verbose, but it was self-referential<sup>6</sup> by including the disputed terms within the construction—twice. A reasonable litigant would not have proposed this construction nor would it have expected it to succeed.

At the *Markman* hearing, Iris Connex argued that its construction would have read on Dell’s accused products. *Acer Case*, Dkt. No. 231 at 7:21–9:6. However, as the Federal Circuit has repeatedly stated, claim constructions are not evaluated in light of the accused products. *Cohesive Techs., Inc. v. Waters Corp.*, 543 F.3d 1351, 1367 (Fed. Cir. 2008). Much of Iris Connex’s claim construction briefing was an attempt to construe the claims in light of the accused products. *See, e.g., Acer Case*, Dkt. No. 217 at 5–11 (E.D. Tex.). In point of fact, what Iris Connex was really trying to do was to import a “fixed” limitation into the claim when the claim language itself made it abundantly clear that the camera (or reading head) was moveable. Iris Connex accused Dell of importing limitations into the claim. While this smoke screen to hide its

---

<sup>6</sup> By “self-referential,” the Court refers to the discredited practice of using the language to be construed to craft the adopted construction. Merely re-arranging the language in question rarely provides valuable guidance to the fact finder.

own efforts to import limitations might be clever, it reveals a lack of candor which the Court is entitled to expect from counsel. Iris Connex's construction was not merely wrong. *See, e.g., SFA Sys., LLC v. Newegg Inc.*, 793 F.3d 1344, 1348 (Fed. Cir. 2015). Rather it was completely divorced from the claim language and the specification, and was an attempt to turn the claim language on its head. Plaintiff's counsel offered no reasonable arguments to adopt such a construction.

## 2. A Flawed Doctrine of Equivalents Analysis

Plaintiff next put forward a doctrine of equivalents argument for the disputed "multi-function and multi-position reading head" limitation. However, that argument simply never existed. *Festo* foreclosed a doctrine of equivalents argument prior to filing suit. *See generally Festo Corp. v. Shoketsu Kinzoku Kogyo Kabushiki Co.*, 535 U.S. 722 (2002). Iris Connex and its counsel should have known this. Despite written warnings from the Defendants citing well established case law, Iris Connex persisted. Iris Connex argued to the Court that the patentee's earlier amending of the limitation "adjustable reading head for producing an image signal" to "multi-position and multi-function reading head for producing an image signal when in a first position using a first lensing and for reading for image conversion using a second lensing when in a second position" was not a narrowing amendment. In other words, Iris Connex argued that "multi-position and multi-function" was not narrower in scope than "adjustable."

To argue that the amendment was not narrowing (thereby avoiding the *Festo* presumption), Iris Connex had to ignore the entire file history. The original claims did not require that the reading head be multi-function or multi-position, only adjustable. The application originally recited "an internal adjustable reading head for producing an image signal." (Dkt. 217-8 at 182.) The Examiner rejected this claim over the prior art. To distinguish the prior art, the applicant

narrowed the claim element: an internal ~~[adjustable]~~ multi-position and multi-function reading head for producing an image signal when in a first position using a first lensing and for reading for image conversion using a second lensing when in a second position. Compare Acer Case, Dkt. No. 217-8 (July 16, 1998 Preliminary Amendment) at 9, with Acer Case, Dkt. 217-11 (May 2, 2000 Amendment) at 3.<sup>7</sup> “Estoppel arises when an amendment is made to secure the patent and the amendment narrows the patent’s scope,” *Festo*, 535 U.S. at 736–37, and that is precisely what occurred here. This is made clear in the missing Office Action that Iris Connex and its counsel never read or reviewed prior to filing suit. Acer Case, Dkt. No. 217-10 (October 27, 1999 Office Action) (the “Missing Office Action”).<sup>8</sup>

Iris Connex also argues that it reasonably believed the “tangential relation” exception to the *Festo* presumption of estoppel should apply and that the “objectively apparent reason for the amendment was unrelated to a movability requirement.” (Dkt. No. 127 at 8.) Iris Connex argued that the applicant relied on only the “multi-function” part of the amendment to differentiate the claimed invention from the prior art. That argument makes no sense. No applicant would include a significant extraneous limitation (“multi-position”) if something substantially less (“multi-function” only) was adequate. See *Felix v. Am. Honda Motor Co.*, 562 F.3d 1167, 1183–84 (Fed. Cir. 2009). The only reasonable reading of the complete prosecution history is that both limitations were necessary to overcome the prior art (Wilska alone or the combination Wilska and

---

<sup>7</sup> The Court notes that the amendment, as it appears in the prosecution history, omits the fact that the word “adjustable” was removed from the claim. Rather, it simply notes the addition of words “multi-position and multi-function.” Acer Case, Dkt. 217-11 at 5.

<sup>8</sup> See Dkt. No. 130 at 15 n.6 (citing to e-mail exchanges that reflect that Iris Connex did not have the complete prosecution history prior to suit). At the hearing, Mr. Yates explained that he was confident that the Missing Office Action did not hinder his ability to assess the strength or weakness of a doctrine of the equivalents argument. (Hearing at 42:5–43:23.) He was mistaken.

Boyd). *See* Missing Office Action at 2–3, (“Boyd discloses lens tilt mechanism . . . . Thus, it would have been obvious to . . . modify Wilska’s system to provide for an adjustable reading head for producing an image signal . . . without having to move the communication device as taught by Boyd”). *See also* Acer Case, Dkt. No. 217-11 (May 2, 2000 Amendment) at 6 (“Neither Wilska et al. nor Boyd et al. have a reading head that is **both** multi-positional and multi-functional.”) (emphasis added.). Put another way, the “multi-position” limitation was added to the claim specifically to overcome the prior art. It was not tangential. It was essential.

As this Court previously explained in its Summary Judgment Order, Iris Connex’s doctrine of equivalents argument contained another deficiency: “The multi-camera / software-toggling system, such as that used by the accused products, is essentially the ‘fundamental opposite’ of the single, multi-positional and multi-functional camera recited in the claims.” (Summary Judgment Order at 44.) Nothing can be the equivalent of its fundamental opposite. This argument failed as a matter of law.

The combination of these deficiencies in Iris Connex’s doctrine of equivalents position persuades the Court that such was not only weak, but exceptionally so.

## **ii. Iris Connex’s Litigation Conduct**

Dell also argues that Iris Connex sought to exploit the high cost to defend complex litigation as a means to extract nuisance settlements from Defendants. It is undisputed that Iris Connex offered to settle its suit against Dell for \$80,000. While \$80,000 is not “extraordinarily low,” that does not end the inquiry. As the Federal Circuit has held, even a \$75,000 settlement offer in the context of a \$20,000,000 case could be considered a nuisance settlement. *Eon-Net LP v. Flagstar Bancorp*, 653 F.3d 1314, 1327 (Fed. Cir. 2011). Moreover, while the settlement demand in this case was significantly higher than those offered in some cases, *see, e.g., eDekka*

*LLC v. 3balls.com, Inc.*, 2015 WL 9225038 (E.D. Tex. Dec. 17, 2015), so were the stakes. To determine whether a settlement offer is fair and made in good faith, it is not the absolute value of the settlement but rather the prospective recovery that must be evaluated, *i.e.*, how much is at stake. *See generally Reynolds v. Beneficial Nat. Bank*, 288 F.3d 277, 284–85 (7th Cir. 2002).

Dell argues that \$80,000 is a nuisance settlement which evidences bad faith because it is below the cost of defense. Iris Connex and Mr. Yates respond that \$80,000 was a thoughtful and realistic settlement offer. Mr. Yates testified that he based his damages model on the Federal Circuit decision in *Summit 6, LLC v. Samsung Elecs. Co., Ltd.*, 802 F.3d 1283 (Fed. Cir. 2015), (*See Yates Decl.* at ¶ 73–74), where the Federal Circuit upheld a per-unit royalty rate of approximately 15 cents per-unit for infringement of a patent teaching a method of intelligent preprocessing of digital photos.

What troubles the Court is not simply that Iris Connex tried to settle the case below the cost of defense. In some cases, a settlement amount below the cost of defense could be a reasonable offer. Rather, if Iris Connex believed the '950 patent truly covered what it said it claimed—essentially front and rear camera functionality, however employed, on a personal communication device—then it essentially would hold a patent claiming the ubiquitous “selfie.” *See Acer Case*, Dkt. No. 217 at 13. If so, Iris Connex should have demanded far more, and the fact that it did not leads the Court to one of two possible conclusions. Either Iris Connex was trying to obtain settlements driven by litigation costs rather than the merits of this case, or it realized that its infringement position was extraordinarily weak. *See Raylon LLC v. Complus Data Innovations*, 2011 WL 13098297, at \*2 (E.D. Tex. Mar. 9, 2011) (“In some situations, a plaintiff asserting a large damages model while making very low offers of settlement early in the case may



indicate that the plaintiff realizes its case is very weak or even frivolous.”). Either conclusion supports granting this motion under Section 285.

The Court also considers it probative that other members of the Yates collective (some owned by Q Patents, some not) have filed hundreds of patent infringement suits in this district, but only one case (not counting this case) has gone as far as claim construction. None of these cases have been tried before a jury. (Yates 94:1–7.) As soon as these cases end, the asserting entities dissolve. (Yates 31:22–32:12.) While this is background information that does not emanate from the present case, it does speak to the totality of the circumstances. Iris Connex has argued that the Court cannot consider the actions of “unnamed and unrelated” third parties in determining exceptionality, but only the facts limited to this single case. (*See generally* Dkt. No. 70.) The Court disagrees. Nothing in the authorities cited by Iris Connex forecloses the Court’s consideration of the conduct of third parties. Indeed, current Federal Circuit authority suggests the opposite. *See, e.g., Eon-Net*, 653 F.3d at 1319, 1325 (“Zimmerman had filed over 100 lawsuits on behalf of *Eon-Net* **or its related entities** asserting infringement of the Patent Portfolio.”) (emphasis added).

In sum, the combined conduct of Iris Connex, Mr. Yates, Mr. Labbit, and Mr. Tadlock persuades the Court that this case was not litigated in good faith.

### **iii. Other Considerations**

This case crossed the Rubicon of exceptionality when the Court concluded that Iris Connex’s case was so weak from the outset that it lacked any real merit. This Court has seen its fair share of infringement contentions and heard its fair share of claim construction arguments. Those presented in this case clearly stand out.

That said, Dell urges a number of additional grounds to support a finding that this case is exceptional. The Court rejects most of those as simply unpersuasive. For example, Dell asserts that “[a]ll asserted claims of [the] patent-in-suit have been determined invalid by the United States Patent and Trademark Office,” during *ex parte* reexamination. (Dkt. No. 130 at 3.) It is true that this Court has previously held that the substantive weakness of a patent may factor into the exceptional case analysis. See *eDekka*, 2015 WL 9225038, at \*2. However, that holding finds no application here. In *eDekka*, the Court concluded that the patent was obviously weak on its face in light of *Alice*. Patents carry a presumption of validity, and the corollary is that a defendant asserting that a patent is “demonstrably weak on its face” confronts a significant hurdle. *Id.* In *eDekka*, that hurdle was overcome because the claims “did not even recite computer components.” *NexusCard, Inc. v. Brookshire Grocery Co.*, 2016 WL 6893704, at \*3 (E.D. Tex. Nov. 23, 2016).

The same is not true here. First, the fact that the USPTO granted Dell’s *ex parte* reexamination petition on June 17, 2016 *after* Iris Connex filed suit in this case says nothing about the substantive weakness of the patent at the time the suit was filed. This Court will not burden patent owners with somehow divining what the Patent Office might do at a future date. Second, *institution* of reexamination is not alone evidence of a patent’s weakness. In fact, institution of an *ex parte* reexamination is not uncommon, and more often than not, patents emerge from reexamination with at least some of their claims intact.<sup>9</sup> Third, the Patent Office issued a Final Office Action rejecting the claims on November 25, 2016, over two months *after* this Court entered its Summary Judgment Order of non-infringement. Finally, the Patent Office uses different

---

<sup>9</sup> See USPTO, *Ex Parte* Reexamination Filing Data – September 30, 2016 available at [https://www.uspto.gov/sites/default/files/documents/ex\\_parte\\_historical\\_stats\\_roll\\_up.pdf](https://www.uspto.gov/sites/default/files/documents/ex_parte_historical_stats_roll_up.pdf).

evidentiary and claim construction standards. *See Large Audience Display Sys., LLC v. Tennman Prods., LLC*, No. 2015-2040, 2016 WL 6123901, at \*4 (Fed. Cir. Oct. 20, 2016). For this reason alone, the argument advocated by Iris Connex—that the Court should consider Dell’s submission of a petition for reexamination as “an admission that Dell is not confident in its non-infringement/claim construction provision, that Iris Connex’s contrary position is non-frivolous, and that fee-shifting and sanctions . . . are inappropriate” (Dkt. No. 25-9 at 2)—fares no better. In this case, the reexamination does not impact the Court’s analysis under Section 285.

However, there are two additional reasons that resonate with the Court and support a finding of exceptionality in this case. First, and the more significant of the two, is that Mr. Yates made an intentional decision to create and undercapitalize Iris Connex as an empty shell. As this case reflects, such a design choice has real world effects, undermines the integrity of the judicial system, and certainly makes a case “stand out.” The Court and those other parties before it have the right to know who is the real party at interest on the other side of any case. The fact that Iris Connex was part of a pattern of setting up empty shell companies is not lost on this Court. This suggests to the Court that Mr. Yates intended to game the judicial system as part of a pattern of continuing conduct.

That said, the Court notes that it will not ordinarily scrutinize litigants’ business decisions, including how they might structure a business or make a decision to open an office in a particular location. “[A] business opens its doors in a particular location for a number of considerations, including the cost of rent, market profitability, cost of doing business, and tax benefits.” *See Medidea, LLC v. Smith & Nephew, Inc.*, 2010 WL 1444211, at \*2 (E.D. Tex. Apr. 12, 2010). Here, however, because of the apparent absence of a missing actor, the Court ordered limited and targeted post-judgment discovery to protect the integrity of the Court’s proceeding. The Court

refused to stay such discovery even when Iris Connex and Q Patents fled to California to file bankruptcy.

Another reason supporting the exceptionality of this case is the admitted sloppiness in prosecuting this case, brought about predominantly by Mr. Yates. (Hearing at 86:10–12 (“We have to admit that there were mistakes made. They shouldn't have been made. My client was sloppy. That’s what it boils down to.”).) These mistakes include disclosure errors, assignment issues, misuse use of form documents, conflicting sworn testimony, and a failure to properly communicate among Mr. Yates, Mr. Labbit, and Mr. Tadlock. Most of these issues were well explored at the hearing and do not deserve extended discussion here. (*See, e.g.*, Hearing at 33:18–39:2, 61:3–62:1 (discussing authority to execute assignment and possible standing issues)); (*id.* at 45:17–50:14, 53:25–54:15 (discussing the Tadlock Law Firm’s engagement agreement)); (*id.* at 55:8–56:22 (discussing failure to disclose Mr. Yates in initial disclosures requiring listing of all persons with “knowledge of relevant facts”).) Some of the more serious issues are elaborated upon below. The Court recognizes that all businesses and lawyers occasionally make mistakes. In the Court’s view, a minor mistake or two made by a lawyer, party, or principal does not mean a case is exceptional. Here, however, the sloppy mistakes made were not minor or isolated. Their collective import does make this case stand out.

**b. Joint and Several Liability of Iris Connex and Mr. Yates**

The Court finds and holds that Iris Connex and Mr. Yates are jointly and severally liable for the fees shifted, pursuant to 35 U.S.C. § 285. As the named plaintiff, the application of fee shifting to Iris Connex is clear. The Court finds that Mr. Yates, having been afforded ample due process, is also liable given that his personal conduct was the dominant cause making this case exceptional. From start to finish, Mr. Yates has been the driving force behind this litigation.

Every reason for this Court’s exceptional case finding emanates from Mr. Yates. The Court is persuaded that not to hold Mr. Yates personally liable would make a mockery out of Section 285.

Mr. Yates conceived and then carried out each step leading up to the filing of this meritless lawsuit. First, he “discovered” the soon-to-expire ’950 patent while searching for “high value” patents. (Yates Decl. at ¶ 14.) Then he contacted the inventor to negotiate the assignment of the ’950 patent, well before he created Iris Connex. (Hearing at 40:23–41:12.) Mr. Yates alone conducted the negotiations to acquire the patent, (*see* Hearing at 38:7–9), before “bringing [Mr. Labbit] in” (Hearing at 61:24). In fact, the inventor, Mr. Robb, never communicated with Mr. Labbit. (*See* Hearing at 38:23.) Mr. Yates “brought” the patent to Mr. Labbit. (Hearing at 61:25–62:1.)

Mr. Yates next created Iris Connex as a subsidiary of Q Patents, the holding company he owns personally. He then designated Mr. Labbit, an employee of another of his holding companies, Spectrum Patents Inc., to be the manager of Iris Connex. (Labbit at 28:20.) Mr. Labbit was manager of Iris Connex in name only. He consulted Mr. Yates on “anything that would affect the economic standing of Iris Connex.” (Labbit at 90:20–24). As an example, Mr. Yates (through Q Patents) controlled the decision about whether or not to spend money on Iris Connex’s behalf. (Labbit at 92:17–93:5.)

After the formation of Iris Connex, it was Mr. Yates—not Mr. Labbit—who executed the assignment acquiring Iris Connex’s only asset. While Mr. Yates acknowledges that Mr. Labbit should have been the one to act for Iris Connex in executing the assignment of the ’950 patent,

both of them testified that Yates personally acted with full authority. (Hearing at 38:20–22.)<sup>10</sup> This assignment contractually obligated Iris Connex to initiate litigation against at least ten defendants by November 30, 2015. (Dkt. No. 128-2 at 2; Hearing at 39:3–11.) In other words, Mr. Yates knew he was contractually obligating Iris Connex to file this lawsuit. It is hard (*vis-à-vis* the exceptionality of this case) to understate the importance of Mr. Yates’ direct and personal control through the pre-suit process of finding and acquiring the ’950 patent, as Iris Connex had no other purpose than to enforce its only asset.

Mr. Yates’ involvement did not end there. He independently performed pre-suit diligence. For example, he reviewed the prosecution history (excluding the Missing Office Action). (*See* Hearing at 41:17–21; 42:6–17 (“It was very clear from the record, and that analysis was done by me prior to even having a decision of wanting the patent.”).) It is also undisputed that Mr. Yates personally controlled the events occurring toward the end of this lawsuit. His involvement in the settlement process is unquestioned. He admitted as much. (*See, e.g.*, Hearing at 65:10–11 (“I have played a key role in settlement.”).) For example, he calculated Iris Connex’s damages model, its settlement offers, and the determination of a reasonable royalty. (Hearing at 65:24–66:25.) He controlled Iris Connex’s settlement posture and how it would reach out to the

---

<sup>10</sup> The Court has been told that Mr. Yates (who is not a member of Iris Connex) had the requisite authority to execute the assignment; assuming such to be the case then the assignment was valid and Iris Connex had standing to sue. (*See* Hearing at 36:18–39:14.) At the hearing, Mr. Yates and Mr. Labbit testified that Yates acted with authority when executing the assignment. (Hearing at 39:9.) However, Mr. Yates then testified that the regulations of Iris Connex “defin[ed] their respective roles.” (*Id.* at 39:12–13.) Those regulations clearly state that the Member (Q Patents and not Mr. Yates) “unless appointed” by Mr. Labbit, has no authority “to act for . . . undertake or assume, any obligation, debt, duty, or responsibility on behalf of the Company.” (Dkt. No. 129-2.) For example, prior to filing bankruptcy, Iris Connex held a special meeting and specifically authorized Brian Yates to file a bankruptcy petition for Iris Connex, which authorization was subsequently certified by Mr. Labbit. (Dkt. No. 34-1 at 22.) While the Court has not seen any formal authorization given to Mr. Yates to execute and accept the assignment of the ’950 patent from AVT, the Court need not determine whether authorization “by phone” is sufficient. (Hearing at 62:4–8.) In any case, in light of Mr. Yates’ individual conduct on behalf of Iris Connex, he has precluded himself from using Q Patents as a shield for him to hide behind. He is directly liable.

Defendants. (Hearing at 66:2–68:6.) When things turned upside down in the face of Dell’s Section 285 motion and the Court’s allowing unexpected post-judgment discovery, Mr. Yates used his personal resources to settle the serially filed cases by paying large sums of money, entering covenants not to sue, and granting licenses to other patents in which Iris Connex had no direct interest. (Hearing at 69:5–72:22.)

Finally, Mr. Yates was directly responsible for the post-judgment events which confirmed the exceptional nature of this case. He bears primary responsibility for the erroneous Rule 7.1 disclosure. He also bears sole responsibility for the decision to declare bankruptcy in California and the successive events that flowed from that decision. As clearly established, he made the decision to put Iris Connex into bankruptcy without first consulting Mr. Labbit. (Labbit Dep. at 78:8–12 (“Q. Were you consulted on the filing of the bankruptcy petition? A. No. I was notified Iris would need to file the petition”).) Every one of these twists and turns arose from his deliberate decision to structure Iris Connex as an empty shell corporation. Consequently, all of the post-judgment discovery matters were the fruit of the tree planted by Mr. Yates alone.

It is true that Mr. Yates did not control every legal argument put forward by Iris Connex. For example, there is no evidence he chose which claims to assert. None of that is of consequence. While Mr. Yates did not actively make some of the litigation decisions in the case, he certainly had input and retained supervisory authority over such matters. (*See* Hearing at 65:10–17; Yates Decl. at ¶ 71 (“Prior to acquiring any patent, I personally complete an analysis of the patent and its file history, and *define an infringement theory that involves a preliminary construction of the relevant claim limitations.*”) (emphasis added).) It is not necessary that Mr. Yates have controlled every substantive aspect of the litigation. It is only important that his conduct made this case exceptional. About that, the Court has no doubt. By the time Mr. Tadlock and Mr.

Labbit became involved, the die had already been cast by Mr. Yates. Then, during the litigation, Mr. Yates held sway over Iris Connex's refusal to dismiss the case. Finally, it was Mr. Yates alone who made the choice to file for bankruptcy. These post-judgment contortions each had their genesis in Mr. Yates' strategic decision to create Iris Connex as an empty shell and thereby avoid Section 285 liability. Without this there would have been no need for post-judgment discovery.

The Court finds *Ohio Cellular* to be instructive as to Mr. Yates' responsibility for the conduct of Iris Connex. See *Ohio Cellular*, 175 F.3d at 1350 (Fed. Cir. 1999). However, unlike the trial court in *Ohio Cellular*, this Court has afforded Mr. Yates ample due process<sup>11</sup> to contest his liability by joining him *sua sponte*. Accordingly, it is both equitable and proper that Mr. Yates be jointly and severally liable for all costs and fees shifted to Iris Connex in this case. The underlying purpose of Section 285 is to deter exceptional litigation. This Court will not look the other way as to Mr. Yates' exceptional conduct while forthright litigants must come to court knowing they face the risk of fee shifting if their case is deemed exceptional.

Failing to extend liability to Mr. Yates personally would effectively negate Section 285. The clear language of Section 285 does not specify against whom fees should be shifted. Congress could have easily spelled that out. It did not. Here, the responsible actor is Brian Yates and this Court finds he caused this lawsuit to be exceptional. He is held by the Court to be personally liable for Dell's attorney fees from the inception of this case through September 2, 2016, and including subsequent briefing on Dell's Section 285 Motion.

---

<sup>11</sup> See *supra* Section III(A)(b), n.5 and *infra* Section IV(C)(b), n.15.



c. **Amount of Fee Award**

An award of fees under Section 285 is typically calculated by “multiplying a reasonable hourly rate by the reasonable number of hours required to litigate a comparable case,” *i.e.*, the “lodestar” method. *Lumen View Tech. LLC v. Findthebest.com, Inc.*, 811 F.3d 479, 483 (Fed. Cir. 2016). The Court may, in its discretion, exclude any hours that are excessive, redundant, or otherwise unnecessary and may reduce the hourly rate if it deems it excessive. *See Hensley v. Eckerhart*, 461 U.S. 424, 434 (1983). A rate is reasonable if it is “in line with those prevailing in the community for similar services by lawyers of reasonably comparable skill, experience and reputation.” *SUFI Network Servs., Inc. v. United States*, 785 F.3d 585, 594 (Fed. Cir. 2015) (citation omitted). In all, “[t]here is no precise rule or formula for making these determinations,” *Eckerhart*, 461 U.S. at 436, and a court may exercise its discretion to adjust the figure based on a variety of factors, including the novelty and difficulty of the issues and the degree of the success achieved, *see Johnson v. Georgia Highway Exp., Inc.*, 488 F.2d 714, 717 (5th Cir. 1974) (enumerating factors).

In light of these principles and pursuant to the Court’s finding that this case is exceptional, the Court awards Dell reasonable attorney fees incurred in this litigation from inception through the Court’s September 2, 2016 Order, and briefing subsequent to such Order insofar as that briefing relates to Dell’s Section 285 Motion. The Court has reviewed the tasks performed by Dell’s counsel. (*See* Dkt. Nos. 132, 139.) The Court is persuaded that most of these tasks were reasonable and necessary to this litigation, with some exceptions.<sup>12</sup> In doing so, the Court has

---

<sup>12</sup> For example, the Court excludes expenses incurred by Dell for its *ex parte* reexamination petition, which is a collateral administrative proceeding before the Patent Office, not this Court. The same exclusion applies to work related to an appeal. The Court has also assessed the reasonableness of the hours and rates which Dell has submitted.

consulted the 2015 American Intellectual Property Law Association (AIPLA) Economic Survey, which is routinely relied upon in intellectual property cases to determine the reasonableness of fee requests. *See, e.g., T&M Inventions, LLC v. Acuity Brands Lighting*, 2016 WL 7441650, at \*1 (E.D. Wis. Dec. 27, 2016). The Court has also weighed the fact that prior to September 2, 2016, Dell was one of 18 Defendants who were then jointly defending against this Plaintiff.

The Court in its discretion believes \$355,000 to be an appropriate and just award of exceptional case fees under Section 285. Such fees are awarded to Dell and are imposed upon and payable by Iris Connex and Brian Yates, jointly and severally.

#### **IV. SANCTIONS**

Much of the same conduct which renders this case exceptional also renders it sanctionable. The Court now discusses such conduct.

##### **A. Rule 11**

###### **a. Legal Standard**

Relevant to patent infringement actions, Rule 11 requires that the patent holder's attorney "interpret the pertinent claims of the patent in issue before filing a complaint alleging patent infringement." *Antonious v. Spalding & Evenflo Cos.*, 275 F.3d 1066, 1072 (Fed. Cir. 2002). In particular, claim constructions are subject to Rule 11(b)(2) which requires legal arguments to be non-frivolous and attorneys to make a "reasonable effort to determine whether the accused device satisfies each of the claim limitations." *Id.* at 1074. To determine whether an attorney has complied with Rule 11, "the standard under which an attorney is measured is an objective, not

---

For example, Dell requests approximately \$275,000 for over 500 hours billed in briefing Dell's Section 285 Motion (Dkt. Nos. 25, 97, 130). This is clearly excessive.

subjective, standard of reasonableness under the circumstances.” *Whitehead v. Food Max of Miss., Inc.*, 332 F.3d 796, 802 (5th Cir. 2003) (en banc).

Once an attorney’s conduct is deemed to have violated Rule 11, “the district court is vested with considerable discretion in determining the ‘appropriate’ sanction to impose upon the violating party.” *Thomas v. Capital Sec. Servs., Inc.*, 836 F.2d 866, 876–77 (5th Cir. 1988). “A sanction imposed under this rule must be limited to what suffices to deter repetition of the conduct or comparable conduct by others similarly situated.” Fed. R. Civ. P. 11(c)(4); *see also Mercury Air Grp., Inc. v. Mansour*, 237 F.3d 542, 548 (5th Cir. 2001) (“[C]ourts must impose the least severe sanction on attorneys and parties who violate Rule 11.”). “The court possesses the discretion to tailor sanctions to the particular facts of the case.” *Thomas*, 836 F.2d at 877. “Deterrence, rather than compensation, has long been recognized as the primary purpose to be achieved by Rule 11 sanctions.” *Raylon LLC v. Complus Data Innovations, Co.*, 2015 WL 11121530, at \*4 (E.D. Tex. May 4, 2015).

**b. Analysis**

**i. Mr. Tadlock**

Dell urges a number of reasons as to why this Court should find Mr. Tadlock in violation of Rule 11. Only one of them is meritorious: Mr. Tadlock advanced a frivolous claim construction.

The Court finds an earlier case from this district to be particularly informative. *See Raylon LLC v. Complus Data Innovations*, 2011 WL 1104175 (E.D. Tex. Mar. 23, 2011). *Raylon* bears obvious similarities to this case. In *Raylon*, the asserted claim required a “display being pivotally mounted on said housing,” and it was asserted against devices whose displays were rigidly mounted to the device’s housing. *Id.* Similar to the cameras here, it was undisputed that the

accused products all had displays that were fixed and did not move. The *Raylon* defendants also filed early dispositive motions for a judgment of non-infringement, asserting that Raylon's infringement claims were not plausible. Further, the parties represented that construction of a single term, the "pivotally mounted" term, would resolve liability in all cases. *Id.* at \*1.

Raylon advanced a similarly nonsensical claim construction arguing the "pivotally mounted" term was met because a user's wrist could pivot while it held the rigidly mounted device. *See Raylon LLC v. Complus Data Innovations*, 6:09-cv-355, Dkt. No. 147 (E.D. Tex. March 9, 2011); *Raylon, LLC v. Complus Data Innovations, Inc.*, 700 F.3d 1361, 1367–70 (Fed. Cir. 2012). On appeal, the Federal Circuit concluded that Raylon's proffered construction was a clear instance where "no objectively reasonable litigant, relying on the single sentence in the specification to support its position, would believe its claim construction could succeed; therefore, Raylon's claim construction is frivolous and thus sanctionable under Rule 11(b)(2)." *Id.* at 1369; *see also Source Vagabond Sys. Ltd. v. Hydrapak, Inc.*, 753 F.3d 1291, 1300–01 (Fed. Cir. 2014).

In this case, Mr. Tadlock violated Rule 11 because he advanced a claim construction divorced from the specification and claim language, ignored the file history, contravened Federal Circuit law, relied heavily on extrinsic evidence to the exclusion of the intrinsic evidence, and asked the Court to adopt a construction that simply did not make any sense. As the Federal Circuit made clear in *Raylon*, this Court has no latitude to determine if Mr. Tadlock acted in good faith, but must sanction him where his arguments failed to pass a purely objective standard of review. *Raylon*, 700 F.3d at 1369; *Source Vagabond*, 753 F.3d at 1301.

The Court notes that Mr. Tadlock received multiple notices from different Defendants that they intended to file for sanctions in this case, and in the face of these warning signs, Iris Connex and its counsel "proceeded through claim construction undeterred." *Raylon*, 700 F.3d at 1370 n.6

(Reyna, J. concurring). As Judge Reyna made clear in his *Raylon* concurrence, the lawyer has a duty to “stop and think and to investigate whether its positions were objectively baseless.” *Id.* Put simply, Mr. Tadlock did not stop and think before plunging ahead with an objectively unreasonable claim construction. Under this objective standard, Mr. Tadlock’s conduct must be sanctioned and the Court cannot consider his underlying conduct or state of mind. That is to say, the Court must react to what he did, not what his intentions were.<sup>13</sup>

While the law constrains this Court as to the conclusion it must reach, the Court has considerable discretion in fashioning an appropriate sanction under Rule 11. *Mendoza v. Lynaugh*, 989 F.2d 191, 195–96 (5th Cir. 1993). Ultimately, the sanction should be educational and rehabilitative in nature, but the absolute minimum to effect deterrence. Fee awards are discretionary if they are appropriate in light of the facts of the case. *See Raylon*, 6:09-cv-355, Dkt. No. 207 at 8 (E.D. Tex. May 4, 2015). While Mr. Tadlock has not received any settlement proceeds in this case, he has had to spend considerable time and expense working on this case without compensation. Indeed, Mr. Tadlock and his firm have spent thousands of hours on this case without any payment whatsoever. (Tadlock Decl. at ¶ 122; *see also id.* 99–104 (describing other adverse impacts of this case).) While this might be said to be an educational sanction in and of itself, the Court is persuaded that it must also impose some additional sanction to further effect

---

<sup>13</sup> In its zeal to find sanctionable conduct to assert against Mr. Tadlock, Dell makes a number of other unpersuasive arguments. The Court rejects them all. In fact, one of these argument relies on a significant misstatement of fact. Dell argues that “[t]he Complaint signed by Mr. Tadlock on behalf of Iris Connex falsely alleged that Iris Connex’s **principal place of business** was in Longview, Texas,” (Dkt. No. 97 at 18; *see also* Dkt. No. 130 at 7–8), because “the ‘principal place of business refers to the place where the corporation’s high level officers direct, control, and coordinate the corporation’s activities,” (*id.* at 9–8) (citing *Hertz Corp. v. Friend*, 599 U.S. 77, 92–93 (2010)). The Complaint actually states that Iris Connex “is a Texas limited liability company with its **principal office** located in the Eastern District of Texas, at 211 E. Tyler Street, Suite 600-A, Longview, Texas 75601.” (Dkt. No. 1 at ¶ 3) (emphasis added). The Court is reluctant to sanction lawyers based on arguments that are simply factually incorrect.

deterrence. In this Court's judgment, payment of \$25,000 by Mr. Tadlock adequately achieves that purpose.

Mr. Tadlock shall pay forthwith the sum of \$25,000 to the Clerk of the Court as a penalty for his conduct in this case. He shall be required, when asked to advise any other court or district in which he may seek admission or leave to practice *pro hac vice*, that he has been formally sanctioned by this Court.

**ii. Mr. Labbit**

Despite Mr. Labbit's role as the manager of Iris Connex, the Court is not persuaded that he is "responsible" for any violation of Rule 11. *See* Fed. R. Civ. P. 11(c)(1). Notably, Dell has not urged the Court to find Mr. Labbit in violation of Rule 11. The Court is persuaded that Mr. Labbit's primary error was that he exercised extremely poor judgment. This must be somewhat attributed to the vulnerabilities of being a relatively new lawyer. The Court is also mindful that Mr. Labbit will long bear a direct association with this case. Even if the Court were persuaded that Mr. Labbit were responsible for a Rule 11 violation, sanctioning him beyond that would not serve any useful or remedial purpose. The Court is persuaded that Mr. Labbit will exercise much better judgment in the future.

Accordingly, the Court does not find that Mr. Labbit has violated Rule 11.

**B. Section 1927**

Pursuant to Section 1927, a district court may shift reasonable fees to any attorney who multiplies the proceedings in any case "unreasonably" and "vexatiously." 28 U.S.C. § 1927; *Proctor & Gamble Co. v. Amway Corp.*, 280 F.3d 519, 525 (5th Cir. 2002). The Fifth Circuit has held that Section 1927 sanctions "require 'clear and convincing evidence, that every facet of the litigation was patently meritless' and 'evidence of bad faith, improper motive, or reckless disregard

of the duty owed to the court.” *Bryant v. Military Dep’t*, 597 F.3d 678, 694 (5th Cir. 2010) (quoting *Procter & Gamble Co.*, 280 F.3d at 525–26); *see also Raylon*, 700 F.3d at 1370 n.6 (“Establishing attorney misconduct under § 1927 implicates a higher level of culpability than Rule 11.”). While Mr. Tadlock prosecuted an objectively weak case on the merits that probably should not have been filed, and advanced an objectively unreasonable claim construction, Dell has not shown by clear and convincing evidence that Mr. Tadlock “multiplied” the proceedings in this case both “unreasonably *and* vexatiously.”

Accordingly, the Court declines to award costs and fees under Section 1927.

### **C. Inherent Power**

#### **a. Legal Standard**

The Court has the inherent power to sanction conduct. *See Chambers v. NASCO, Inc.*, 501 U.S. 32, 44 (1991). The inherent power allows the Court to address “a full range of litigation abuses” including conduct beyond the confines of this case. *Id.* at 46. The inherent power allows the Court to sanction non-parties that may be beyond the purview of the Federal Rules or Section 1927, but are closely tied to the litigation. *See Intellect Wireless, Inc. v. Sharp Corp.*, 87 F. Supp. 3d 817, 844–45 (N.D. Ill. 2015) (opining that inherent power provides trial court with ability to sanction pre-suit conduct). For example, “[a] court may sanction a non-party corporate officer who acts improperly on behalf of a corporate defendant and who attempts to avoid sanctions by hiding behind the corporate veil.” *Anchondo v. Anderson, Crenshaw & Assocs., LLC*, 2011 WL 4549279, at \*4 (D.N.M. Sept. 29, 2011), *aff’d sub nom.*, 511 F. App’x 736 (10th Cir. 2013) (“[T]he evidence demonstrates a peculiarly close relationship between Mr. Dunn and Mr. Backal. Mr. Dunn was a signatory on ACA bank accounts; accounts show him to be a manager of ACA; Mr. Dunn was a managing officer of two corporations with Mr. Backal; and Mr. Dunn located his law

office at ACA's offices until ACA went out of business." Sanctions under the inherent power require a finding of bad faith. *Carroll v. Jaques Admiralty Law Firm, P.C.*, 110 F.3d 290, 294 (5th Cir. 1997).

Two years after the Supreme Court's decision in *Chambers*, the Eastern District of Michigan addressed a trial court's inherent power to sanction non-parties in light of *Chambers*. See *Helmac Prod. Corp. v. Roth (Plastics) Corp.*, 150 F.R.D. 563 (E.D. Mich. 1993). *Helmac* articulated a two-part test which this Court considers persuasive. "To be subject to the Court's inherent power to sanction, a non-party not subject to court order must (1) have a substantial interest in the outcome of the litigation and (2) substantially participate in the proceedings in which he interfered." *Id.* at 568. *Helmac* is not unique. Many other cases recognize a court's inherent authority to sanction non-parties who are entwined in the pending litigation. See also, e.g., *Manez v. Bridgestone Firestone N. Am. Tire, LLC*, 533 F.3d 578, 585 (7th Cir. 2008) ("No matter who allegedly commits a fraud on the court—a party, an attorney, or a nonparty witness—the court has the inherent power to conduct proceedings to investigate that allegation and, if it is proven, to punish that conduct."); *Bartos v. Pennsylvania*, 2010 WL 1816674, at \*5 (M.D. Pa. May 5, 2010) ("It is also beyond serious dispute that this power extends, not only to parties in civil litigation, but also to other persons, such as witnesses, who may be embroiled in that litigation."). More recently, the Northern District of California relied upon its inherent power to sanction after it found that certain principals were the leaders and decision makers behind a "national trolling scheme." See *Ingenuity13 LLC v. Doe*, 651 F. App'x 716, 718 (9th Cir. 2016).

Mr. Yates and his conduct also fall within the purview of the Court's inherent power. Mr. Yates has an interest in the outcome of this litigation and substantially participated in these proceedings.



**b. Analysis**

The record is checkered with Mr. Yates' bad faith conduct. Having presided over this case for more than a year, the Court is left with the firm conviction that Mr. Yates intentionally structured Iris Connex to effectuate an end-run around Section 285.

**i. Mr. Yates' Shell Operation**

In his declaration, Mr. Yates outlined how his shell operation works. (*See* Yates Decl. at ¶ 10.) According to Yates, this segment of his career began when, as a part of his law practice, he saw a gap in the legal market for small patentees where the amount of potential damages was not large enough to obtain representation from larger firms. (*Id.*) In light of these experiences, he decided to become an advocate for the individual inventors and small companies who were unable to find contingency counsel. (*Id.*) He acquired patents on a profit sharing basis, retaining a different lawyer to assert the patents on a pure contingency basis. (*Id.*) He would create new LLCs to enforce the patents against infringers and, through the patent assignment, agreed to share 50 percent of any resulting revenue with the prior patent owner. (*Id.*)

There are, of course, other ways to accomplish the same result without the use of multiple corporate shells. For example, Mr. Yates, an experienced patent litigator, could have represented each inventor directly. He could have referred the inventor to a different lawyer and taken a referral fee. It is not the Court's duty to dictate how one should operate his or her business, yet the intentional way Mr. Yates structured his business in this case reveals that one of his major goals was to shield himself personally if any of these risky ventures "went south." To accomplish this, he devised an approach to circumvent the law. This is sanctionable.

The facts refute the "inventor David versus corporate Goliath" story that Mr. Yates attempts to tell. (*See, e.g.*, Yates Decl. at ¶ 71 ("These patent owners would otherwise be largely

excluded from the legal system.”.) Mr. Yates acquired the ’950 patent from AVT, which is itself a patent holding and enforcement company located in Canada. AVT is owned by Garry Robb, the inventor of the ’950 patent. If Mr. Robb believed that his patent was being infringed, he could have retained an attorney to enforce his patents. History reveals that this is not simply conjecture. As the many *DataQuill* cases reveal, Mr. Robb, who had an interest in the named plaintiff DataQuill, was well acquainted with the nature of patent litigation. In fact, a little more than three years ago, in *DataQuill Ltd. v. ZTE Corp.*, 2:13-cv-00634-JRG (E.D. Tex.), this Court saw a jury return a \$31.5 million verdict against ZTE and in favor of DataQuill. Clearly, Mr. Robb was not “left out in the cold” without the help of Mr. Yates.<sup>14</sup>

The facts here tell a different story than the one Mr. Yates portrays. Mr. Yates “discovered” the soon-to-expire ’950 patent doing his regular research to find acquirable “high value” patents. (Yates Decl. at ¶ 14.) Then, he reached out to Mr. Robb to acquire his patent, presumably without solicitation. (*Id.* at ¶ 15.) There is no indication that Mr. Robb had any intention of asserting the ’950 patent against Dell or any of the other Defendants until Mr. Yates approached him. Mr. Yates then created Iris Connex as an empty shell and retained a lawyer on a contingency to assert its only asset. Iris Connex never functioned independently of Mr. Yates. When it became clear that, despite his efforts, this structure might unravel and expose him personally, Mr. Yates scrambled to throw roadblocks into the post-judgment discovery process. All of this unnecessary time and expense could have been avoided if, instead of attempting to dodge liability under Section 285, Mr. Yates had simply disclosed to Dell and the Court the true

---

<sup>14</sup> See also *Iris Connex, LLC v. Apple, Inc.*, 2:15-cv-1911, Dkt. No. 12-9 (E.D. Tex.) (AVT 2008 Year End Report stating that AVT had assigned 50 percent of its interest in its IP Portfolio including the ’950 patent to a private investment company that “helped AVT to secure and pay for a top-notch group of patent attorneys” to protect AVT’s intellectual property rights).

corporate ownership and the real parties in interest in this lawsuit. Such was the very narrow, targeted discovery the Court sought in the first instance. (*See* Dkt. No. 40 at 12:6–9) (“I am going to order targeted discovery on the identity of the real party at interest, standing in the position of the Plaintiff.”).

There is, of course, nothing inherently wrong with Mr. Yates or anyone else capitalizing on underused patents in the marketplace. However, one cannot abuse the judicial process through the creation of shell entities to facilitate the assertion of otherwise meritless claims as part of a scheme to avoid the risks that Section 285 creates. Equally important, the Court must protect the functioning of its own processes. Mr. Yates’ decision to create an empty shell and then hide its corporate parent until the eleventh hour (while at all times being sure any resulting monetary gains would flow to him unimpeded) led to the judicial inefficiencies and delays recounted herein, which far exceed those present in an ordinary case.

Based on the information before it, the Court concludes that Mr. Yates’ above described conduct rises to the level of an abuse of the judicial system.

**ii. Rule 7.1 Disclosures**

While Iris Connex and Respondents concede that the initial Rule 7.1 disclosure was incorrect, the reason behind such remains unclear. Mr. Yates suggested in his deposition testimony that he did not understand Q Patents to be a “corporate parent.” (*See* Yates Dep. at 48:2–49:21.) That understanding is neither a plausible nor objectively reasonable interpretation of “corporate parent,” especially by an attorney like Mr. Yates. Even a cursory survey of other cases would have revealed to him that whenever a wholly owned limited liability company has a corporation as its sole member, that corporation is to be disclosed pursuant to Rule 7.1. *See, e.g., Arcelormittal Indiana Harbor LLC v. Amex Nooter, LLC*, 2016 WL 3746369, at \*1 (N.D. Ind. July

13, 2016); *Gardner v. Nationstar Mortg. LLC*, 2014 WL 7239496, at \*3 (E.D. Cal. Dec. 16, 2014); *Yagoozon, Inc. v. Fun Express, LLC*, 2014 WL 1922793, at \*2 n.2 (D.R.I. Feb. 10, 2014); *Corp. Trade, Inc. v. Golf Channel*, 2013 WL 5375623, at \*1 (S.D.N.Y. Sept. 24, 2013).

Mr. Yates and Mr. Labbit now essentially disavow any involvement with the Rule 7.1 disclosure, attempting to lay the blame at the feet of Mr. Tadlock. (Yates Decl. ¶ 36–43.) They attribute this “clearly erroneous” filing to a “miscommunication” between Mr. Yates and Mr. Tadlock. (Hearing at 22:9–11; Yates Decl. at ¶ 37.) Mr. Tadlock has represented other Yates enforcement entities prior to this lawsuit. In those cases, the corporate structures differed from that of Iris Connex in that Mr. Yates had direct ownership of the enforcement entity. Prior to filing this lawsuit, Mr. Tadlock inquired of Mr. Yates if the ownership of Iris Connex was the same as the other entities in the prior cases in which Mr. Yates was the sole member. (*See* Hearing at 48:19–49:14.) Mr. Tadlock understood the answer to be “yes.” (*See id.*) When the Court asked Mr. Tadlock if he had any knowledge of Q Patents when he filed the original Rule 7.1 disclosure, he said no. (Hearing at 46:5–7.) This explanation makes sense. Q Patents is unmentioned and completely absent from the assignment of the ’950 patent. It is also absent from every other Iris Connex document subject to the Discovery Order’s production mandate. *See* Acer Case, Dkt. No. 136 at 2–3 (E.D. Tex.).

The Court is not persuaded by Mr. Yates’ latest explanation, in large part, because his current explanation (miscommunication) is in tension with his prior explanation (misunderstanding of “corporate parent”). Further, this issue is not localized to lawsuits brought by Yates entities represented by Mr. Tadlock. The same erroneous corporate disclosures exist in various other lawsuits filed by other Yates enforcement entities in this District, including cases involving attorneys other than Mr. Tadlock. (*See, e.g.*, Hearing at 57:6–59:21 (discussing

erroneous disclosures in other cases pending in this district).) This Court is left with the conclusion that either Mr. Yates has the same miscommunications with all of his attorneys or he never intended to communicate his true corporate structure to any of his attorneys. The most reasonable conclusion, based on the complete record before the Court and the credibility of the witnesses, is the latter. This is why the 7.1 disclosure is important in this case.

Both the Court, the other parties, and the public have a right to know who is the real party in interest in any case. As an example, Iris Connex's standing to bring this lawsuit may have been hidden from the Court and Dell as a result of this error. As another example, this filing deprived Dell and the other Defendants from pleading an alter ego theory of recovery or a direct liability theory against Mr. Yates early in the case. This is also why Respondents' procedural attacks on this Court's joinder of Respondents post-judgment must fail. As Dell correctly points out, it did not learn that Mr. Yates was the real party in interest until *after* the Court ordered post-judgment discovery. (Dkt. No. 130 at 14–15.) On the equities, Respondents cannot claim a lack of proper joinder when they have unclean hands. To be sure, those claims fail on the law as well, (*see* Dkt. No. 11 at 11–12), and the Court has taken clear steps to provide all parties with ample due process.<sup>15</sup>

Considering the totality of the circumstances, the Court is persuaded that Mr. Yates intended to keep Q Patents out of sight as his “ace in the hole” against the prospect that this lawsuit would open the door, just as it has, to a Section 285 motion, such that he could produce Q Patents as a hidden shield to his own liability. The complete absence of any mention of Q Patents until

---

<sup>15</sup> Compare *Nelson v. Adams USA, Inc.*, 529 U.S. 460 (2000) (reversing *Ohio Cellular* and holding that party must be given an opportunity to respond and contest personal liability for a fee award prior the entry of liability against party), with Dkt. No. 74 (giving parties notice and opportunity to respond, including 100 pages of collective responsive briefing, and an in-person hearing opportunity to testify and present oral argument to the Court).

the aborted post-judgment effort to bury this problem beneath the sands of the Bankruptcy Court in California speaks volumes.

Despite Mr. Yates' late-breaking efforts to compensate and settle with the other 17 of the original 18 Defendants, he is ultimately left to confront a problem of his own making. He chose to file multiple lawsuits each employing an empty shell assertion company. He intentionally obscured his own presence, and failed to disclose any other intermediary empty shell, all while carefully keeping the pathway open for any money to flow directly to him. This atmosphere not only precipitated an assortment of sloppy mistakes, (*see e.g.*, Hearing 35:23–36:1), it also contributed to the advancement of an objectively unreasonable infringement position in this case—the most compelling reason why this case is exceptional.

**c. Sanction**

Any sanction must not only be proportionate to the harm suffered, but must also be sufficient to deter future litigants from engaging in similar behavior. Nevertheless, it should be the “least severe sanction available.” *Carroll*, 110 F.3d at 294. Here, Mr. Yates' sanctionable conduct not only necessitated the Court's ordering of post-judgment discovery, but it prolonged such discovery while his twists and turns ran their course.

An appropriate monetary sanction is to order Mr. Yates to pay Dell all reasonable costs and fees brought about by Mr. Yates' conduct. *Cf. Atlanta Gas Light Company v. Bennett Regulator Guards, Inc.*, IPR2015-00826 (P.T.A.B. Dec. 6, 2016), Paper 39, at 8 (sanctioning Petitioner and awarding Patent Owner costs and fees related to discovery of the real party in interest after issuance of decision on the merits). Here, the Court tailors its monetary sanction only as to those additional costs and expenses brought about by the above misconduct. Such costs include not only the hours and expenses generated in conducting the Court ordered post-judgment

discovery, but includes many of Dell's responses to the various filings seeking to stay or delay the case urged after Dell filed its Section 285 Motion. However, these costs do not include the costs of briefing Dell's Section 285 Motion, which the Court has included in its award of fees under Section 285. This sanction is limited to additional expenses and costs related to the post-judgment discovery necessitated by Mr. Yates' misconduct described above.

After adjusting hours and rates appropriately, the Court invokes its inherent power and Orders Mr. Yates to pay Dell \$152,000 as a sanction for his misconduct.

In addition, Mr. Yates is ordered to personally deliver, via certified-mail or overnight delivery, full and complete copies of this Opinion to each defendant sued by any Yates enforcement entity, in all cases pending as of the date of this Opinion, and in which such entity (a) had a corporate parent and (b) failed to disclose such parent pursuant to Rule 7.1, regardless of whether that disclosure was subsequently corrected. Such notice should be sent to each defendant's counsel and the presiding judge in each of those cases. Mr. Yates shall file a Notice of Compliance with this Court within 30 days listing each pending case, identifying to whom he sent this Opinion and attaching proof of compliance therewith.

## **V. CONCLUSION**

This is the clearest example of an exceptional case to yet come before the undersigned. Simply put, if this case is not an exceptional case, then there are none.<sup>16</sup>

---

<sup>16</sup> In making these decisions herein, the Court has not considered the argument that Dell has raised that Iris Connex's efforts to establish venue in this district amounted to a sham. While Dell may have had a viable argument for transfer under Section 1404, the Court stayed this case to pursue its mini-*Markman* before venue was considered. As a result, any venue-related facts have not been factored into the Court's determinations herein.

This challenging set of circumstances confirms the important benefits of the Court's active case management. This is especially true when a single trial court manages multiple related cases as a means of providing the direct oversight that each branch of government is duty bound to exercise within its own area of responsibility.

## **VI. FINAL JUDGMENT**

For the reasons stated herein and in the Court's Memorandum Opinion and Order of September 2, 2016 (Dkt. No. 21), and pursuant to Rule 58 of the Federal Rules of Civil Procedure, the Court hereby **ORDERS** and **ENTERS JUDGMENT** as follows:

- Dell does not infringe any of the asserted claims of U.S. Patent 6,177,950;
- This case is exceptional under 35 U.S.C. § 285;
- Dell, as the prevailing party, shall recover its attorney fees under 35 U.S.C. § 285, in the amount of \$355,000 ("Exceptional Case Fees"). This amount includes reasonable costs and fees incurred prior to the Court's Summary Judgment Order and also the reasonable costs and fees incurred in briefing Dell's Section 285 Motion (Dkt. Nos. 25, 97, and 130). Iris Connex and Mr. Brian Yates are jointly and severally liable for payment of Dell's Exceptional Case Fees;
- Dell, as the prevailing party, shall recover its costs in the amount of \$624.39 from Iris Connex. (*See* Dkt. No. 24.)
- The Court sanctions Mr. Brian Yates pursuant to its inherent power. As a monetary sanction, Mr. Yates shall pay Dell \$152,000 accounting for additional expenses and costs related to the post-judgment discovery necessitated by Mr. Yates' misconduct. As a further and non-monetary sanction, Mr. Yates shall disseminate this Opinion as ordered herein and within 30 days file a Notice of Compliance with the Court as directed; and
- The Court sanctions Mr. Charles Tadlock pursuant to Federal Rule of Civil Procedure 11(b)(2). As a sanction, Mr. Tadlock shall pay \$25,000 to the Clerk of this Court.

This is a final judgment.



**So ORDERED and SIGNED this 25th day of January, 2017.**

  
\_\_\_\_\_  
RODNEY GILSTRAP  
UNITED STATES DISTRICT JUDGE