

**IN THE UNITED STATES DISTRICT COURT
FOR THE EASTERN DISTRICT OF TEXAS
MARSHALL DIVISION**

IRIS CONNEX, LLC,

Plaintiff,

v.

ACER AMERICA CORP. et al.,

Defendants.

Case No. 2:15-cv-1909-JRG

MEMORANDUM OPINION AND ORDER

Before the Court are motions to dismiss pursuant to Fed. R. Civ. P. 12(b)(6) filed by Defendants Dell Inc. (Dkt. No. 13, Case No. 2:15-cv-1915), Huawei Device USA, Inc. (Dkt. No. 37, Case No. 2:15-cv-1909)¹, Sony Mobile Communications (USA), Inc. (Dkt. No. 40), Acer America Corp. (Dkt. No. 44), Panasonic Corporation of North America (Dkt. No. 51), Sharp Electronics Corp. (Dkt. No. 52), HTC America Inc., (Dkt. No. 53), BlackBerry Corporation (Dkt. No. 57), Hewlett-Packard Company (Dkt. No. 72), Toshiba America Information Systems, Inc. (Dkt. No. 75), Microsoft Corporation (Dkt. No. 78), Apple Inc. (Dkt. No. 81), Lenovo (United States) Inc. and Motorola Mobility LLC (Dkt. No. 82), and Fujitsu America, Inc. (Dkt. No. 84) (the “Motions to Dismiss” filed by the “Moving Defendants”).

For the reasons stated below, pursuant to Federal Rule of Civil Procedure 12(d), the Court converts these motions into motions for summary judgment under Federal Rule of Civil Procedure 56, **GRANTS** such motions for summary judgment and as a result, **DISMISSES** all claims against all defendants **WITH PREJUDICE**.

¹ All citations to record are to Case No. 2:15:cv-1909 unless otherwise stated.

I. Background

Plaintiff Iris Connex, LLC (“Iris Connex”) is a Texas limited liability company with its principal place of business allegedly located at 211 East Tyler Street, Suite 600-A, Longview, Texas. (Dkt. No. 1 at ¶ 3); *but see* Dkt. No. 17, Case No. 2:15-cv-1915) (arguing that physical inspection of Iris Connex purported office shows “it is not there, and never has been there”). Plaintiff is the owner by assignment of United States Patent No. 6,177,950 (“the ’950 Patent”) entitled “Multifunctional portable telephone.” (Dkt. No. 1 at ¶ 9.)

Iris Connex alleges that the Defendants infringe Claim 1 of the ’950 Patent by making, using, selling, or offering for sale various smartphones and tablets containing a front-facing and rear-facing camera. Claim 1 of the ’950 patent reads:

A personal communication device, comprising:
a display for displaying data and video signals;
a loudspeaker for generating an audible signal;
a microphone for receiving an audio signal;
a keypad for entering data;
a telecommunications interface for receiving and transmitting information; and
an internal multi-position and multi-function reading head for producing an image signal when in a first position using a first lensing and for reading for image conversion using a second lensing when in a second position.

(Dkt. No. 1-1 at 23) (disputed phrase is emphasized). Plaintiff also asserts Defendants’ devices infringe dependent claims 2, 16, 19, 24 and 30; that certain accused smartphones infringe Claim 22; and that certain accused devices that include fingerprint recognizing sensors infringe Claim 35.

1. Technology

The ’950 Patent relates to a personal communication device that includes a number of elements, such as “an internal multi-position and multi-function reading head for producing an image signal when in a first position using a first lensing and for reading for image conversion

using a second lensing when in a second position.” ’950 Patent at Abstract.² The specification states that “[t]he present invention, known as the ‘Multiphone’ is a multi-functional hand held portable device, which provides a fully integrated video teleconferencing, data entry, and image capture system.” *Id.* at 1:8–11. Figure 1A of the ’950 Patent illustrates an exemplary embodiment of the “Multiphone.”

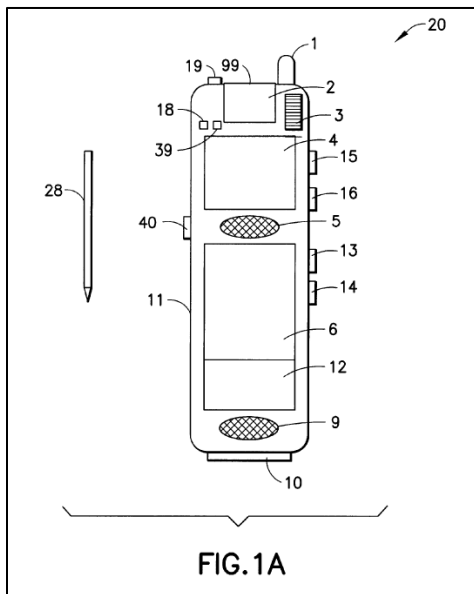

Id. at Figure 1A. The specification states that the device includes “a reading head 2, for example a camera or infra-red optical reading head (e.g. laser diode), suitable for capturing data and/or images” *Id.* at 5:38–40. The specification further states that “[t]he reading head is preferably interchangeable through the use of a clip-on enclosure 99, to allow the use of different types of reading heads.” *Id.* at 5:42–44. The specification adds that “[a]n adjustment thumbwheel 3,

² The Abstract of the ’950 Patent provides as follows:

A personal communication device includes a display for displaying data and video signals; a loudspeaker for generating an audible signal; a microphone for receiving an audio signal; a keypad for entering data; a telecommunications interface for receiving and transmitting information; and an internal multi-position and multi-function reading head for producing an image signal when in a first position using a first lensing and for reading for image conversion using a second lensing when in a second position.

connected to the clip-on enclosure 99 by suitable means (e.g. a gearbox), allows the reading head to be adjusted to various working positions.” *Id.* at 5:44–47.

The '950 Patent resulted from PCT International Application PCT/CA97/00029, which was filed on January 17, 1997. The relevant timeline and sequence of events in the prosecution of the '950 Patent follows:

Date	Event	Exhibit(s)	Reference Term
January 17, 1997	Original PCT International Application for patent PCT/CA97/00029 filed ³	Dkt. Nos. 217-3 & 217-4	Original PCT Application
July 17, 1997	PCT Written Opinion of International Preliminary Examining Authority	Dkt. No. 217-5	PCT Written Opinion
April 27, 1998	PCT International Preliminary Examination Report	Dkt. No. 217-6	PCT Preliminary Exam Report
July 16, 1998	Application enters national stage at the USPTO under 35 U.S.C. §371	Dkt. No. 217-7	
July 16, 1998	Preliminary Amendment of applicant filed with the USPTO	Dkt. No. 217-8	Preliminary Amendment
October 27, 1999	Office Action, Non-Final Rejection	Dkt. Nos. 217-9 & 217-10	Non-Final Rejection
April 26, 2000	Amendment in Response to Non-Final Office Action	Dkt. No. 217-11	Responsive Amendment
July 14, 2000	Notice of Allowance from USPTO	Dkt. Nos. 217-12 & 217-13	Notice of Allowance
January 23, 2001	Issuance date of the '950 Patent	Dkt. No. 217-2	

The specification and figures of the Original PCT Application are similar to those in the '950 Patent. The Original PCT Application contained 29 claims. Independent claim 1 of the Original PCT Application recites “a camera reading sensor on a rotational pivot for sensing images

³ The '950 Patent claims priority to Great Britain provisional patent application 9600804, dated January 17, 1996.

in various positions allowing interactive communication.” (Dkt. No. 217-3 at 31).⁴

As indicted in the PCT Written Opinion and the PCT Original Exam Report, the Original PCT Application was rejected. (Dkt. No. 217-5 at 2; Dkt. No. 217-6 at 3). The reason for rejection was “Non-establishment of opinion with regard to novelty, inventive step and industrial applicability.” (*Id.*) The examiner found that Great Britain publication GB 2289555A (“Wilska” or the “Wilska Reference”) disclosed a hand held unit comprising a camera reading sensor for sensing images allowing interactive communication. (Dkt. No. 217-5 at 5–7; Dkt. No. 217-6 at 7–9). The examiner further found that a skilled person, seeing that Wilska was disadvantageous due to the camera reading sensor having a fixed viewing position, would combine Wilska with a reference identified as JP-A-06 141 306. (*Id.*) The examiner stated that the second reference disclosed an audio visual data entry unit with a camera reading sensor on a rotational pivot. (*Id.*)

The examination of the application then moved to the USPTO, with the patentee submitting a Preliminary Amendment that canceled claims 1–29 of the Original PCT Application and added claims 30-70. (Dkt. No. 217-7 at 2; Dkt. No. 217-8 at 1–7). Claims 30-70 in the Preliminary Amendment correspond to claims 1–41 of the ’950 Patent.⁵ Claim 30 of the Preliminary Amendment is identical to claim 1 of the ’950 Patent, except for the last element. The last element of claim 30 of the Preliminary Amendment recites “an internal adjustable reading head for producing an image signal.” (Dkt. No. 217-8 at 2.)

In response to the Preliminary Amendment, the USPTO issued a Non-Final Rejection. (Dkt. No. 217-9; Dkt. No. 217-10). The examiner rejected the claims under 35 USC §103 as being

⁴ Unless otherwise indicated, all citations to documents filed with the Court are to the ECF docket and page number assigned by the Court’s filing system.

⁵ For instance, claim 30 of the Preliminary Amendment can be compared to claim 1 of the ’950 Patent, claim 31 of the Preliminary Amendment can be compared to claim 2 of the ’950 Patent, and so on.

unpatentable over Wilska in view of U.S. Patent 5,436,654 (“Boyd” or the “Boyd Reference”). (Dkt. No. 217-10 at 2). The examiner found that Boyd disclosed a lens tilt mechanism for a video conferencing unit. (Dkt. No. 217-10 at 3). In response to the Non-Final Rejection, the patentee amended the last element of claim 30 as follows:

an internal [adjustable] multi-position and multi-function reading head for producing an image signal when in a first position using a first lensing and for reading for image conversion using a second lensing when in a second position.

(Dkt. No. 217-11 at 3). In the Responsive Amendment, the patentee argued that “all of those cited references appears [sic] to lack such a reading head having multiple functions.” (*Id.* at 5–6). Specifically, with respect to Wilska and Boyd, the patentee argued that “[n]either Wilska et al. nor Boyd et al. have a reading head that is both multi-positional and multi-functional. Moreover, since Wilska et al. and Boyd et al. lack a multi-positional and multi-functional reading head, they necessarily lack the recited ‘first lensing’ and ‘second lensing.’” (*Id.* at 6).

In response to the amendments, the examiner allowed the claims. (Dkt. No. 217-12 at 2-6). The examiner did not provide any details and only stated that “the prior art does not teach a personal communication device recited in the independent claims 30” (*Id.* at 3.) Claims 30–70 in the Responsive Amendment were renumbered as 1–41, respectively, in the ’950 Patent. (*Id.* at 2.)

2. Procedural History

On March 8, 2016, Dell filed a motion to dismiss the Complaint under Federal Rules of Civil Procedure 12(b)(6) and 12(b)(3) (Dkt. No. 13, Case No. 15-cv-1915). In its motion, Dell argues that the Complaint does not explain how the accused Dell products, “tablets with a front-facing camera and a rear-facing camera,” could infringe a claim directed to a personal

communication device having a “multi-position and multi-function reading head with first and second positions” as claimed in the ’950 Patent. According to Dell, not only are such allegations unclear—little more than a “formulaic recitation of the elements of a cause of action” mandating dismissal under *Iqbal* and *Twombly*—but the allegation of infringement is also implausible. Under the plain language of this claim, Dell contends that the “multi-position . . . reading head” must be capable of being oriented into “a first position” and “a second position,” and that “a front-facing camera” and “a rear-facing camera” could not comprise a singular reading head capable of being oriented into a first and second position. Between April 4, 2016, and April 25, 2016, the other Moving Defendants filed similar motions under Federal Rule of Civil Procedure 12(b)(6), each urging dismissal of the Complaint on similar implausibility grounds.⁶

Plaintiff contends that the “multi-position and multi-function reading head . . .” limitation as described in Claim 1 is met by a unified “Camera” system in each of the Accused Products. (*See, e.g.*, Dkt. No. 123-1 at 8–9). The front-facing camera of each “Camera” system constitutes the first lensing position of the claimed reading head, and the rear-facing camera of each “Camera” system constitutes the second lensing position of the claim; or vice-versa. According to Plaintiff’s infringement theory, such system is “multi-position” because, using the software, the user can toggle between these two lensings and positions. (Dkt. No. 217 at 11–14.) Thus, it is Plaintiff’s contention that *both* cameras in the Accused Products, along with the user interface and the software controlling the user interface, comprises the claimed “reading head.” (*See* Dkt. No.

⁶ Neither Defendants TCT Mobile, Inc. and TCT Mobile (US) Inc. (“TCT Mobile”), Samsung Electronics America, Inc. (“Samsung”), nor LG Electronics U.S.A., Inc. moved to dismiss the Complaint under 12(b)(6). TCT Mobile has joined in the supplemental summary judgment briefing, Dkt. Nos. 234 and 242. (*See* Dkt. No. 240). On August 1, 2016, Samsung moved for judgment on the pleadings under Federal Rule of Civil Procedure 12(c) joining in and adopting arguments made in the Motions to Dismiss. Samsung also joined in the supplemental summary judgment briefing, Dkt. Nos. 234 and 242. Defendants LG Electronics U.S.A., Inc. and ASUS Computer International joined Defendants Lenovo Inc. and Motorola LLC’s Motion to Dismiss. (*See* Dkt. Nos. 90, 110.)

241 at 10 (“Iris Connex accuses the Accused Products, including the camera system as a ‘multi-position and multi-function reading head [camera]’ with at least two lensings It does not accuse a ‘front camera’ or a ‘rear camera’ separately.”) To the extent such “Camera” system does not literally meet the claim limitation, Plaintiff argues it infringes under the doctrine of equivalents. (*See* Dkt. No. 233 at 3–5.)

Through the process of conducting an early review of these Motions to Dismiss, the Court became aware that the Motions to Dismiss turned on the construction of the last element of Claim 1 of the ’950 patent. Accordingly, on May 25, 2016, the Court *sua sponte* entered an Order setting an early claim construction in this case on July 20, 2016 limited to disputed terms from the last element of Claim 1 of the ’950 patent. (Dkt. No. 176) *See Wordcheck Tech, LLC v. Alt-N Techs., Ltd.*, No. 6:10-CV-457, 2012 WL 975725, at *2 (E.D. Tex. Jan. 11, 2012) (opining that a “mini-*Markman*” is appropriate early in a case where “construction of a very narrow set of terms could resolve the case as to most, if not all, parties.”); *Uniloc USA, Inc. v. Inmage Corp., LLC*, No. 6:12-CV-93-LED, 2013 WL 3871360, at *5 (E.D. Tex. July 24, 2013) (“The Court utilizes the mini-*Markman* proceeding to address terms that, if construed, are case dispositive.”). The Court next ordered the parties to meet-and-confer and jointly submit a list of proposed terms in need of construction. (Dkt. No. 176.) The Court considered the parties’ joint submission and ordered that the following terms in the last element of Claim 1 be briefed and argued for claim construction: “a[] . . . multi-position . . . reading head” and “an internal multi-position and multi-function reading head.” (Dkt. No. 180.)⁷ On July 20, 2016, the Court conducted an early

⁷ The Court required the Defendants to comply Patent Local Rule 3-3 and 3-4 by June 16, 2016. The rule requires accused infringers to produce “[s]ource code, specifications, schematics, flow charts, artwork, formulas, or other documentation sufficient to show the operation of any aspects or elements of an Accused Instrumentality identified by the patent claimant in its P. R. 3-1(c) chart.” (*See, e.g.*, Dkt. Nos. 194, 195, 196, 198, 199, 200, 201, 206.)

and targeted claim construction hearing to determine the proper construction of the disputed terms.

During briefing for the Motions to Dismiss and early claim construction, the parties submitted various materials outside the pleadings. The Court deemed these materials to be helpful and relevant to the issues before the Court. Therefore, pursuant to Fed. R. Civ. P. 12(d), the Court converted the Motions to Dismiss into motions for summary judgment under Rule 56, *see Trinity Marine Prods., Inc. v. United States*, 812 F.3d 481, 487 (5th Cir. 2016), and gave notice to the parties of the same at the claim construction hearing. (*See* Dkt. No. 231 at 71:6–22.) The Court instructed the parties to submit materials that would be relevant to such determination and ordered the parties to submit the materials they each considered to be relevant to the motion, accompanied by a ten page brief by August 8, 2016. (*See id.* at 72:7–22; Dkt. No. 229.) The Court later allowed the parties to file seven pages to respond to issues raised by the opposing parties by August 29, 2016, (*see* Dkt. No. 238.).

II. Discussion

“An infringement analysis entails two steps. The first step is determining the meaning and scope of the patent claims asserted to be infringed. The second step is comparing the properly construed claims to the device accused of infringing.” *Markman v. Westview Instruments, Inc.*, 52 F.3d 967, 976 (Fed. Cir. 1995) (citations omitted).

1. Claim Construction

The parties’ dispute focuses on the meaning and scope of one phrase in the ’950 Patent: “an internal multi-position and multi-function reading head.” For the reason, stated below the Court finds that the phrase “**an internal multi-position and multi-function reading head**” should be construed to mean “**a single internal multi-function reading head that is physically**

moveable.”

a. Claim Construction Standards

“It is a ‘bedrock principle’ of patent law that ‘the claims of a patent define the invention to which the patentee is entitled the right to exclude.’” *Phillips v. AWH Corp.*, 415 F.3d 1303, 1312 (Fed. Cir. 2005) (en banc) (quoting *Innova/Pure Water Inc. v. Safari Water Filtration Sys., Inc.*, 381 F.3d 1111, 1115 (Fed. Cir. 2004)). To determine the meaning of the claims, courts start by considering the intrinsic evidence. *See id.* at 1313; *C.R. Bard, Inc. v. U.S. Surgical Corp.*, 388 F.3d 858, 861 (Fed. Cir. 2004); *Bell Atl. Network Servs., Inc. v. Covad Commc’ns Group, Inc.*, 262 F.3d 1258, 1267 (Fed. Cir. 2001). The intrinsic evidence includes the claims themselves, the specification, and the prosecution history. *See Phillips*, 415 F.3d at 1314; *C.R. Bard, Inc.*, 388 F.3d at 861. Courts give claim terms their ordinary and accustomed meaning as understood by one of ordinary skill in the art at the time of the invention in the context of the entire patent. *Phillips*, 415 F.3d at 1312–13; *Alloc, Inc. v. Int’l Trade Comm’n*, 342 F.3d 1361, 1368 (Fed. Cir. 2003).

The claims themselves provide substantial guidance in determining the meaning of particular claim terms. *Phillips*, 415 F.3d at 1314. First, a term’s context in the asserted claim can be very instructive. *Id.* Other asserted or unasserted claims can also aid in determining the claim’s meaning because claim terms are typically used consistently throughout the patent. *Id.* Differences among the claim terms can also assist in understanding a term’s meaning. *Id.* For example, when a dependent claim adds a limitation to an independent claim, it is presumed that the independent claim does not include the limitation. *Id.* at 1314–15.

“The foundation of judicial claim construction is the ‘written description’ in the specification.” *Fenner Invs., Ltd. v. Cellco P’ship*, 778 F.3d 1320, 1323 (Fed. Cir. 2015). Thus,

“claims ‘must be read in view of the specification, of which they are a part.’” *Id.* (quoting *Markman v. Westview Instruments, Inc.*, 52 F.3d 967, 979 (Fed. Cir. 1995) (en banc)). “[T]he specification ‘is always highly relevant to the claim construction analysis. Usually, it is dispositive; it is the single best guide to the meaning of a disputed term.’” *Id.* (quoting *Vitronics Corp. v. Conceptor, Inc.*, 90 F.3d 1576, 1582 (Fed. Cir. 1996)); *Teleflex, Inc. v. Ficoso N. Am. Corp.*, 299 F.3d 1313, 1325 (Fed. Cir. 2002). This is true because a patentee may define his own terms, give a claim term a different meaning than the term would otherwise possess, or disclaim or disavow the claim scope. *Phillips*, 415 F.3d at 1316. In these situations, the inventor’s lexicography governs. *Id.* The specification may also resolve ambiguous claim terms “where the ordinary and accustomed meaning of the words used in the claims lack sufficient clarity to permit the scope of the claim to be ascertained from the words alone.” *Teleflex, Inc.*, 299 F.3d at 1325. But, “[a]lthough the specification may aid the court in interpreting the meaning of disputed claim language, particular embodiments and examples appearing in the specification will not generally be read into the claims.” *Comark Commc’ns, Inc. v. Harris Corp.*, 156 F.3d 1182, 1187 (Fed. Cir. 1998) (quoting *Constant v. Advanced Micro-Devices, Inc.*, 848 F.2d 1560, 1571 (Fed. Cir. 1988)); *see also Phillips*, 415 F.3d at 1323. The prosecution history is another tool to supply the proper context for claim construction because a patent applicant may also define a term in prosecuting the patent. *Home Diagnostics, Inc., v. Lifescan, Inc.*, 381 F.3d 1352, 1356 (Fed. Cir. 2004) (“As in the case of the specification, a patent applicant may define a term in prosecuting a patent.”).

Although extrinsic evidence can be useful, it is “less significant than the intrinsic record in determining the legally operative meaning of claim language.” *Phillips*, 415 F.3d at 1317 (quoting *C.R. Bard, Inc.*, 388 F.3d at 862). Technical dictionaries and treatises may help a court understand the underlying technology and the manner in which one skilled in the art might use

claim terms, but technical dictionaries and treatises may provide definitions that are too broad or may not be indicative of how the term is used in the patent. *Id.* at 1318. Similarly, expert testimony may aid a court in understanding the underlying technology and determining the particular meaning of a term in the pertinent field, but an expert’s conclusory, unsupported assertions as to a term’s definition are entirely unhelpful to a court. *Id.* Generally, extrinsic evidence is “less reliable than the patent and its prosecution history in determining how to read claim terms.” *Id.*

b. The Parties’ Positions

<u>Disputed Term</u>	<u>Plaintiff’s Proposal</u>	<u>Defendants’ Proposal</u>
“an internal multi-position and multi-function reading head”	“an internal multi-position and multi-function reading head with at least two lensings, wherein such reading head may comprise one or more cameras, and wherein “camera” should be read within the context of ‘an internal multi-position and multi-function camera’ and otherwise has its plain and ordinary meaning within the context in which it is used, and which is not limited to merely the lens(es) nor to merely the lens(es) and image sensor.”	“a multi-function reading head that is physically moveable within the device” To the extent “reading head” is construed: “a multi-function reading head that is physically moveable within the device; where the “reading head” has a single sensor.”

The parties dispute whether the recited “reading head” must be “physically moveable,” as Defendants propose or only needs to be “capable of being oriented in different directions,” as Plaintiff proposes. The parties also dispute whether the “reading head” can be “one or more cameras,” as Plaintiff proposes, or if it is limited to a “single sensor,” as Defendants propose. The parties also dispute whether a “camera” should be “limited to merely the lens(es)” or “to merely the lens(es) and image sensor.”

Plaintiff argues that the recited “multi-position and multi-function reading head/camera with at least two lensings” must be construed as a whole and in context. (Dkt. No. 217 at 27.) Plaintiff contends that the actual words of the last limitation of claim 1 are common, and are not

difficult to understand, particularly in light of claim 2 identifying the reading head as “a camera.” (*Id.*) Plaintiff submits that the disputed phrase should be given its plain and ordinary meaning, with the added clarification that the “multi-position and multi-function reading head” must have at least two lensings. (*Id.*)

Additionally, Plaintiff contends that Defendants are trying to insert a “physically moveable” limitation and are trying to impose that the “reading head” has “a single sensor.” (*Id.* at 28.) Plaintiff argues that there are many types of “cameras” that exist, and that the words that describe the characteristics of the camera provide critical context and give life and meaning. (*Id.*) Plaintiff further argues that extrinsic evidence illustrates that a “camera” means more than just a lens or just a lens and image sensor, and that a “camera” can have multiple lensings and/or multiple sensors. (*Id.* at 29) (citing Dkt. No. 217-16 through Dkt. No. 217-29).

Plaintiff also argues that Figure 3A and Figure 9 demonstrate that a number of elements are required to meet the claim limitation of being “multi-position and multi-function.” (Dkt. No. at 29-32.) According to Plaintiff, the “multi-position and multi-function reading head [camera]” with at least two lensings is not synonymous with the “camera 2” identified in the specification. (*Id.* at 33.) Plaintiff contends that “camera 2” does not include several additional components that embodiments of the reading head/camera must have to be “multi-position” and “multi-function. (*Id.* at 32.) Plaintiff further argues that the claims are clear that the “reading head” of claim 1 may include a rotational pivot (claim 5), a rotational reflective mirror (claim 7), a light source (claim 8), and/or a shroud for the light source (claim 9), which are not included as part of “camera 2” in Figure 6. (*Id.* at 33.)

In response to Defendants’ proposed “physically moveable” construction, Plaintiff argues that the words “physical” and “physically” do not appear in the ’950 Patent, and that the word

“moveable” only appears in the text of claims 40 and 41. (*Id.*) Plaintiff further argues that there is nothing in the claims, the specification, the file history, or any extrinsic evidence that (1) requires “multi-position” to mean “physically moveable within the device;” (2) that requires the “multi-position and multi-function reading head/camera” to be “physically moveable within the device;” or (3) that limits the reading head/camera to something that is “physically moveable within the device.” (*Id.*) According to Plaintiff, the portion of the specification that discusses multiple positions focuses only on the orientation of the reading head with respect to the personal communication device itself. (*Id.* at 34) (citing ’950 Patent at 3:40–4:9).

Plaintiff also argues that the when the applicant intended to limit the claim to a device with a “rotational pivot” that was “physically moveable within the device,” he knew how to do so. (Dkt. No. 217 at 34.) Plaintiff contends that independent claim 1 of the Original PCT Application contained a limitation identifying “a camera reading sensor on a rotational pivot for sensing images in various positions allowing interactive communication.” (*Id.*) Plaintiff argues that the “rotational pivot” language was eliminated when the applicant filed his Preliminary Amendment, with the express purpose of “ensur[ing] that the Applicant claims the subject matter to which it is entitled.” (*Id.*) Plaintiff contends that claim 1 of the ’950 Patent includes no “rotational pivot” limitation, but instead, requires a “multi-position and multifunction reading head [camera]” with at least two lensings. (*Id.*)

In response to Defendants’ proposed “single sensor” requirement, Plaintiff argues that there is nothing in the claims, the specification, the file history, or any extrinsic evidence that requires the “reading head” to have “a single sensor,” or limits the “reading head” to having “a single sensor.” (*Id.* at 35.) Plaintiff contends that because the “multi-position and multi-function reading head [camera]” is required to have two lensings, a reasonable embodiment of claim 1

would have different sensors associated with the different lensings. (*Id.*) Plaintiff further argues that Defendants' proposed "single sensor" limitation also runs contrary to the established rule of claim construction that "a" means "one or more." (*Id.* at 35–36.) Plaintiff contends that there is no disclaimer, prosecution history estoppel, or "clear intent" in the '950 Patent to depart from this established rule. (*Id.* at 36.)

Defendants respond that the claim language at issue necessarily requires the multi-position reading head to be able to move between at least two positions within the device. (Dkt. No. 219 at 8.) According to Defendants, the "multi-position" reading head must be capable of being in a "first position" at one point in time ("when in a first position") and of being in a "second position" at another point in time ("when in a second position"). (*Id.*) Defendants argue that the reading head must be physically moveable in order to be in different positions at different points in time. (*Id.*)

Defendants also argue that Plaintiff ignores the claim language and fails to offer any contrary construction of the term "multi-position." (*Id.* at 5.) According to Defendants, Plaintiff argues that a reading head can be a "multi-position" reading head even if that reading head cannot move from a "first position" to a "second position." (*Id.* at 8.) Defendants contend that Plaintiff focuses primarily on what the claim *may* cover (*e.g.*, "may include one or more cameras" and "is not limited to merely the lens(es) nor to merely the lens(es) and image sensor"). (*Id.* at 8-9.) Defendants argue that the dispute properly before the Court is whether the "multi-position" reading head must be moveable. (*Id.* at 9.)

Defendants further argue that the specification is consistent with the plain meaning that an internal "multi-position" reading head must be able to be in two different positions at different points in time. (*Id.*) According to Defendants, the patent discloses that the "multi-position" reading head must be physically moveable inside the device. (*Id.*) (citing '950 Patent at 1:13–14, 5:38–40,

5:42–47, 3:28–40, 3:42–47). Defendants contend that none of the embodiments describe a stationary multi-directional reading head with multiple sensors, as Plaintiff proposes. (Dkt. No. 219 at 10.) Defendants further argue that the remainder of the specification describes an embodiment where the “reading head 2” is embodied in “camera 2,” such as an “on chip camera,” which is contained within clip-on enclosure 99. (*Id.* at 10) (citing ’950 Patent at 7:32–44, 7:51–61, 7:62–8:3, 10:35–38, 10:49–56, 14:5–9, Figure 6).

Defendants further contend that Figure 6 of the ’950 Patent illustrates the type of reading head configuration that is recited in claim 1. (Dkt. No. 219 at 11) (citing ’950 Patent at 10:36–48). Defendants argue that Figure 6 shows the multi-position reading head housed within the clip-on enclosure. (Dkt. No. 219 at 11) According to Defendants, the multi-position reading head in this embodiment (camera 2) can rotate into three different positions corresponding to three different lensings (93, 94, and 95). (*Id.*)

Defendants further argue that the file history confirms the plain meaning of the claim language. (*Id.* at 12–13) (citing Dkt. Nos. 217–8, 217–10, 217–14, 217–15, 217–11). According to Defendants, the prosecution history indicates that claim 1 requires an internal reading head that is not merely “adjustable.” (Dkt. No. 219 at 13) (citing Dkt. 217–15 at 3:34–67, 4:1–31, Figure 7). Defendants argue that the claimed reading head must be physically moveable so that it can perform one function “when in a first position” and perform another function “when in a second position.” (Dkt. No. 219 at 13.)

Defendants also argue that claims 5, 7, and 37 all recite specific reading head structures that further limit the reading head in claim 1 to a particular type of physical movement. (*Id.* at 14.) Defendants contend that claims 10 and 11 similarly require the device of claim 1 to further include specific types of structures for moving the reading head. (*Id.*)

Regarding Plaintiff's construction for "reading head," Defendants argue that Plaintiff attempts to re-define the "reading head" to include "at least two lenses" and also tries to define a "camera" as "not limited to merely the lens(es) nor to merely the lens(es) and image sensor." (*Id.*) Defendants contend that claim 1 recites lensings as being used by the reading head, but not as part of the reading head. (*Id.*) Defendants further argue that the specification discloses that the reading head (*e.g.*, camera 2) moves relative to the lenses. (*Id.* at 15 (citing '950 Patent at 10:49–54, Figure 6).) Defendants contend that the dependent claims confirm that the reading head moves relative to the lensings. (Dkt. No. 219 at 15 (citing '950 Patent at claims 6 and 37).) Defendants also argue that Plaintiff's construction would render the dependent claims nonsensical. (Dkt. No. 219 at 15 (citing '950 Patent at claims 5, 6, and 37)).

Regarding Plaintiff's "one or more cameras" proposal, Defendants contend that the claim requires a reading head that can perform one function when in a first position, and another function when in a second position. (Dkt. No. 219 at 16.) According to Defendants, a first camera fixed in a first position and a second camera fixed in a second position, do not meet these requirements, and thus directly contradict the claim language. (*Id.*) Defendants argue that the Federal Circuit has consistently held that where singular and plural claim elements "are defined in relation to each other," then the recitation of "a" component related to multiple separate elements is limited to a single, unitary component. (*Id.* (citing *Abtox, Inc. v. Exitron, Corp.*, 122 F.3d 1019, 1022–24 (Fed. Cir. 1997) (as amended, 131 F.3d 1009)).)

Defendants also argue that in order for a multi-position and multi-function reading head (*e.g.*, a camera as recited in claim 2) to meet the recited positions limitation it does not suffice to have two cameras, each able to perform one of the functions when in just the one corresponding position. (Dkt. No. 219 at 17.) Defendants further contend that dependent claim 2 specifies that

this “reading head is a camera,” not that the reading head “may comprise one or more cameras.” (*Id.* at 17-18.) Defendants argue the requirements of claim 1 cannot be satisfied by one camera fixed in a first position and another camera fixed in a second position. (*Id.* at 18.) Defendants further argue that Plaintiff’s construction would also “render the claims invalid for lack of written description.” (*Id.*) Defendants contend that the specification does not describe or contemplate that a single “reading head” can contain more than one sensor for performing the claimed limitations. (*Id.* (citing ’950 Patent at 5:38–44, 10:33–58, Figure 6.)

Regarding Plaintiff’s reliance on extrinsic evidence, Defendants argue that the bulk of this evidence addresses different types of cameras and is irrelevant to the meaning of “reading head.” (Dkt. No. 219 at 18.) Defendants also argue that it is black letter law that the “claims may not be construed with reference to the accused device.” (*Id.* at 19) (*Wilson Sporting Goods Co. v. Hillerich & Bradsby Co.*, 442 F.3d 1322, 1330-31 (Fed. Cir. 2006)). According to Defendants, the Court should disregard Plaintiff’s references to the accused products and should reject Plaintiff’s proposal to define “reading head” in terms of a “camera.” (Dkt. No. 219 at 19.)

Defendants further argue that the Court should disregard Plaintiff’s cited Wikipedia entries and articles as irrelevant hearsay because they were published far after the time of invention (*Id.*) Defendants contend that use of Wikipedia is particularly problematic because it is unreliable and potentially changes on a day-to-day basis. (*Id.* at 20.) Defendants further contend that the third-party patents that were filed after the date of invention carry little weight as extrinsic evidence. (*Id.*) Finally, Defendants argue that it is improper to rely on extrinsic evidence to broaden the claims or contradict the intrinsic record. (*Id.*)

Plaintiff replies that Defendants attempt to define the “multi-position and multi-function reading head [camera]” strictly in terms of a preferred embodiment and thereby insert an

additional limitation of “physically moveable within the device.” (Dkt. No. 221 at 5.) Plaintiff argues that that “multi-position” is not a complicated word and is not difficult to understand. (*Id.*) Plaintiff contends that the plain-and-ordinary-meaning definitions do not require anything to be “physically moveable.” (*Id.* at 6-7.) In addition, Plaintiff argues that, to the extent any construction of “multi-position” is necessary, it can be defined as “capable of being oriented in different directions with respect to the personal communication device,” or “capable of being oriented to different situations or conditions with respect to the personal communication device.” (*Id.* at 6.)

Plaintiff further argues that there is nothing in the specification or file history limiting “multi-position” to “physically moveable.” (*Id.*) Plaintiff also contends that there is nothing in the specification that teaches away from the way the accused products operate, where multiple positions are achieved using multiple camera lensings and a software switch to change or toggle from one position to the other. (*Id.* at 7.) Plaintiff argues that there is no place in the file history or specification where the patentee disclaimed the construction it seeks or disavowed this scope. (*Id.*)

Plaintiff also contends that there was no amendment during prosecution that is contrary to its proposed construction. (*Id.*) Plaintiff argues that the applicant’s amendment had nothing to do with being “physically moveable.” (*Id.*) Plaintiff contends that the amended claim language distinguished Wilska and Boyd because each of those references lacked a reading head that was both multi-positional and multi-functional, and they also lacked the recited first lensing and second lensing. (*Id.*)

Plaintiff further argues that there was no effort by the patentee to act as its own lexicographer and explicitly define “multi-position.” (*Id.* at 8.) Plaintiff contends that the examples Defendants reference are described as a “preferred embodiment” and never as “the invention” or “the current invention.” (*Id.*) Plaintiff also argues that Defendants’ proposed requirement that a

component of the “multi-position and multi-function reading head [camera]” be “physically moveable” is merely “a specific feature of particular embodiments that should not be imported into the construction” here. (*Id.*) (citing *Koninklijke KPN N.V. v. Samsung Elecs. Co., Ltd.*, 2016 WL 2610649 at *21 (E.D. Tex. May 6, 2016)).

Plaintiff contends that Defendants incorrectly argue that the lensings are not part of the reading head. (Dkt. No. 221 at 9.) Plaintiff argues that in any applicable plain and ordinary meaning of “camera,” a camera has a lens, and that claim 2 expressly states that a reading head may be “a camera.” (*Id.*) Plaintiff contends that the examples cited by Defendants, Figure 6 and claim 37, describe one embodiment where the device could have separate, respective lensings for various positions of the reading head. (*Id.*) Plaintiff states that these examples do not demonstrate that lensings are necessarily separate from the “multi-position and multi-function reading head [camera].” (*Id.*)

In response to Defendants’ argument concerning the term “camera,” Plaintiff argues that a key part of its claim construction position is that “multi-position and multi-function reading head [camera]” is a single claim element that must be construed as a whole. (*Id.* at 10.) Plaintiff contends that the term “reading head [camera]” cannot be divorced from its context. (*Id.*) Plaintiff further argues that Defendants cannot prove an exception to the general rule that “a” means “one or more.” (*Id.*) According to Plaintiff, a construction of “one or more” is consistent with the claim language and the file history. (*Id.* at 11.)

Plaintiff also argues that Defendants do not contend that anything in the extrinsic evidence is incorrect or inaccurate. (*Id.*) Plaintiff states that Defendants do not offer any contrary evidence. (*Id.*) Plaintiff further argues that the cited patent references are from the relevant time period. (*Id.* at 12) (citing Dkt. No. 217-25 through Dkt. No. 217-28). According to Plaintiff, nothing in the

extrinsic evidence contradicts the intrinsic record. (Dkt. No. 221 at 12.) Plaintiff also contends that Defendants do not contest any of Plaintiff’s facts or characterizations of how the accused products work. (*Id.*) Finally, Plaintiff argues that the Court may consider the accused products in order to understand the claim construction disputes. (*Id.* at 13.)

c. Analysis

The phrase “an internal multi-position and multi-function reading head” appears in claim 1 of the ’950 Patent. The intrinsic evidence indicates that “multi-position” means “physically moveable.” The only description of the recited “multi-position” reading head is one that moves (*e.g.*, rotates) within the device. For example, the specification states that the device includes “[a]n adjustment thumbwheel 3, connected to the clip-on enclosure 99 by suitable means (*e.g.* a gearbox), allows the reading head to be adjusted to various working positions.” ’950 Patent at 5:44–47. Similarly, the specification states that “[t]he position of the camera 2 can be adjusted via the thumbwheel 3 and/or a servo motor 65.” *Id.* at 7:62–63.⁸ The specification further describes the positions of the reading head as follows:

In position **1** the reading head is in a vertical position and faces up to point at the user.

In position **2** the reading head is in a horizontal position and faces out horizontally from the user.

In position **3** the reading head is in a vertical position and faces down to point away from the user.

Id. at 3:41–47. The specification adds that position 1 “[a]llows the capture of the end users face to enable a video teleconferencing capability between another compatible device either in the field, at home or place of work.” *Id.* at 3:50–53. The specification further states that position 2 “[a]llows the user easy access to capture images to facilitate the identification of products and/or items

⁸ The specification describes “reading head 2, for example a camera or infra-red optical reading head (*e.g.* laser diode).” ’950 Patent at 5:38–40.

and/or persons, for example information such as bar codes, dot codes, blob codes or in effect any suitably coded data or distinctive feature which can be used for identification purposes.” *Id.* at 3:58–63. The specification also states that position 3 “[a]llows the user to capture data and/or images below the device while viewing the self same data and/or image on the display screen.” *Id.* at 3:64–66. As indicated, the specification discloses that the reading head is physically moved to a different position to perform a different function.

In summary, every embodiment disclosed in the ’950 Patent indicates that “multi-position” requires the reading head to be physically moveable. Indeed, the embodiment disclosed in Figure 6 is described as having “a camera 2 which is mounted on a rotational printed circuit board (PCB) 91 centrally located on a pivotal axis 98,” and that “[a] servo motor 65, controlled by the processor (41, FIG. 3) via a servo controller (64, FIG. 3), can be used to rotate the rotational PCB 91 through 180° into three distinct functional positions.” *Id.* at 10:35–44. Figure 6 shows the multi-position reading head housed within the clip-on enclosure.

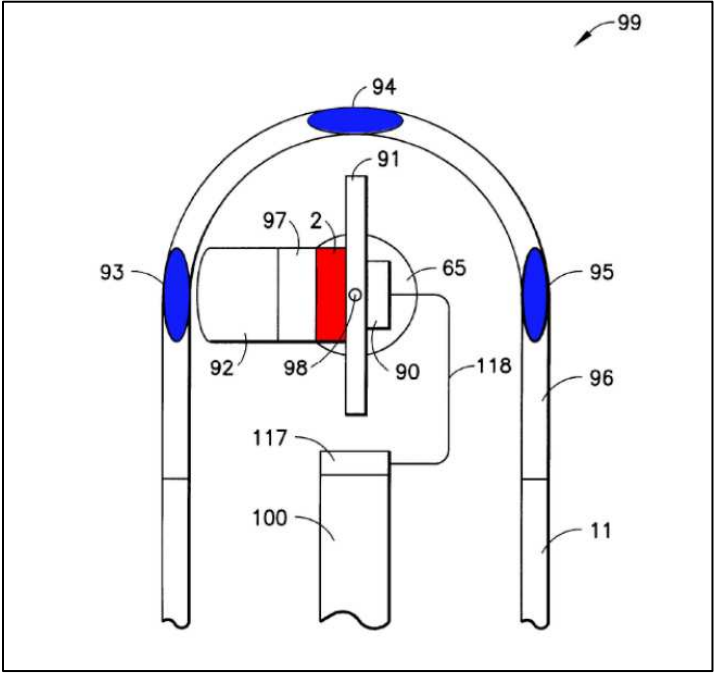

In this embodiment, the multi-position reading head (camera 2) (in red) can rotate into three different positions corresponding to three different lensings (93, 94, and 95) (in blue). This configuration is like the one recited in claim 1, which requires the multi-position, multi-function reading head (camera 2, in red) to perform a first function when in a first position using a first lensing (rotated to face one of the lensings 93, 94, or 95, in blue) and to perform a second function when in a second position using a second lensing (rotated to face a different one of the lensings). The specification contains no other embodiments or indication that the recited “reading head” is required to be anything but “physically moveable.”

The structure of the claims further indicates that “multi-position” means “physically moveable.” Claim 1 recites that the “reading head” produces an image signal when in a first position and is used for image conversion when in a second position. This indicates that the reading head is physically moved from the recited “first position” to the recited “second position.” The dependent claims narrow the type of physical movement required of the “multi-position” reading head. For example, dependent claim 5 recites that “the reading head includes a rotational pivot which rotates to three positions.” Likewise, dependent claim 7 recites that “the reading head includes a rotational reflective mirror.”

The dependent claims go to further recite specific structure for achieving the physical movement. For example, claim 10 recites “a thumbwheel for controlling the reading head,” and claim 11 recites “a servo motor for controlling the reading head.” In addition, independent claims 41 and 42 recite “an internal adjustable multi-function reading head *moveable* through a range of 180 degrees and having multiple settable positions.” (emphasis added). Thus, the claim language itself indicates that “multi-position” means physically moveable. Accordingly, the Court finds that “physically moveable” is the construction that “most naturally aligns with the patent’s description

of the invention.” *See Trustees of Columbia Univ. v. Symantec Corp.*, 811 F.3d 1359, 1366 (Fed. Cir. 2016).

The prosecution history further confirms that the “multi-position reading head” is “physically moveable” from the “first position” to the “second position.” Claim 1 of the issued ’950 Patent was originally filed as claim 30 of the Original PCT Application. (Dkt. 217-8 at 2.) Application claim 30 recited “an internal adjustable reading head for producing an image signal.” (*Id.*) The examiner rejected claim 30 and other claims as obvious over Wilska and Boyd. (Dkt. 217-10 at 2-3.) Wilska discloses an embodiment with a multi-function, but stationary, camera unit. (Dkt 217-14 at 9, 10, 13.) Boyd discloses a video conferencing device with an adjustable camera lens. (Dkt. 217-15 at 3:34–67, 4:1–31, Figure 7.)

Application claim 30 was amended as follows:

“an internal multi-position and multi-function [adjustable] reading head for producing an image signal when in a first position using a first lensing and for reading for image conversion using a second lensing when in a second position.”

(Dkt. 217-11 at 3.) The patentee explained:

Independent Claim 30 has been amended to now recite that the personal communication device includes “an internal multi-position and multi-function reading head for producing an image signal when in a first position and for reading for image conversion when in a second position.” Neither Wilska et al. nor Boyd et al. have a reading head that is both multi-positional and multi-functional. Moreover, since Wilska et al. and Boyd et al. lack a multi-positional and multi-functional reading head, they necessarily lack the recited “first lensing” and “second lensing.”

(*Id.* at 6.) The file history confirms that “multi-position” means “physically moveable.” Claim 1 requires an internal reading head that is not merely “adjustable,” as recited in Application claim 30. Indeed, the Boyd reference described a camera with an adjustable lens. (Dkt. 217-15 at 3:34–67, 4:1–31, Figure 7.) Clearly, the recited “reading head” must be physically moveable so that it

can perform one function “when in a first position” and perform another function “when in a second position.”

Plaintiff argues that multi-position implies more than one position, but not necessarily physical movement. Specifically, Plaintiff contends that the scope of the claims includes two different reading heads or image sensors (*i.e.*, cameras) oriented at different positions. Plaintiff further contends that the cameras do not have to physically move but instead could be controlled by software that switches between the two fixed-position cameras. The Court disagrees with Plaintiff’s argument that the scope of the claims includes a stationary multi-directional reading head with multiple image sensors or cameras. This is beyond the scope of the claim language.

As Plaintiff conceded during the claim construction hearing, there is nothing in the intrinsic record disclosing two reading heads or two image sensors, much less two image sensors being controlled by a software toggle. The Court recognizes that the scope of the claims should not be limited to the disclosed embodiments. *Phillips v. AWH Corp.*, 415 F.3d 1303, 1323 (Fed. Cir. 2005) (“[W]e recognize that the distinction between using the specification to interpret the meaning of a claim and importing limitations from the specification into the claim can be a difficult one to apply in practice.”); *see also Comark Communs., Inc. v. Harris Corp.*, 156 F.3d 1182, 1186–87 (Fed. Cir. 1998) (“[T]here is sometimes a fine line between reading a claim in light of the specification, and reading a limitation into the claim from the specification”). However, the Court finds that Plaintiff’s interpretation is overly broad and effectively divorced from the intrinsic evidence. *Slimfold Mfg. Co. v. Kinkead Industries, Inc.*, 810 F.2d 1113, 1116 (Fed. Cir. 1987) (“Claims are not interpreted in a vacuum, but are part of and are read in light of the specification.”).

A person of ordinary skill would understand that the intrinsic evidence indicates that the

recited “reading head” is physically moveable between at least two positions. This is the scope of the actual invention and is the proper understanding of the phrase “multi-position.” *Retractable Techs., Inc. v. Becton*, 653 F.3d 1296 (Fed. Cir. 2011) (“In reviewing the intrinsic record to construe the claims, we strive to capture the scope of the actual invention, rather than strictly limit the scope of claims to disclosed embodiments or allow the claim language to become divorced from what the specification conveys is the invention.”). Indeed, the Court is not limiting the claims to the types of physical movement described in the disclosed embodiments, but instead finds that claim 1 requires the reading head to be physically moveable between the recited first and second positions. While each of the disclosed embodiments uses a different mechanism to move the reading head between different positions, nothing describes or suggests a stationary multi-directional reading head with multiple image sensors, as Plaintiff proposes. *See Profectus Tech. LLC v. Huawei Techs. Co.*, 823 F.3d 1375, 1381 (Fed. Cir. 2016) (“In every embodiment disclosed in the specification, the picture display or frame includes a feature for mounting the device to a wall or on a tabletop The specification does not disclose a bare embodiment in which the picture display or picture frame lacks a feature for mounting.”)

Regarding Plaintiff’s proposal that the reading head may include “at least two lensings,” the Court rejects this argument. Claim 1 indicates that the lensings are used by the reading head, but are not necessarily required to be a part of the reading head. Specifically, claim 1 recites “an internal multi-position and multi-function reading head for producing an image signal when in a first position using a first lensing and for reading for image conversion using a second lensing when in a second position.” There is no reason to redraft the claim to explicitly require the reading head to include “at least two lensings.” Indeed, the intrinsic evidence indicates that the recited “lensings” may not be part of the “reading head.” For example, the specification discloses that the

reading head (*e.g.*, camera 2) moves relative to the lenses. '950 Patent at 10:49–54 (“In each functional position, respective lensing 93, 94, and 95 incorporated in the lens body 96 assists in the correct focusing of the camera 2.”). Likewise, Figure 6 illustrates the moveable camera 2 separate from the lens body 96 that incorporates lensings 93, 94, and 95.

Plaintiff agrees that this is one embodiment where the device could have separate, respective lensings for various positions of the reading head. (Dkt. No. 221 at 9.) Plaintiff argues that these examples do not demonstrate that lensings are necessarily separate from the “multi-position and multi-function reading head [camera].” (*Id.*) However, it is also true that these examples demonstrate that the reading head is not necessarily required to include two lensings. More importantly, Plaintiff has not provided any persuasive rationale why the Court should redraft claim 1 so that it would potentially exclude a preferred embodiment. *Vitronics Corp. v. Conceptronic, Inc.*, 90 F.3d 1576, 1583 (Fed. Cir.1996) (stating that a construction that excludes a preferred embodiment “is rarely, if ever, correct and would require highly persuasive evidentiary support.”).

In addition, each of the dependent claims that recite “lensings” does so as a structure added to the personal communication device, and not as a feature of the reading head. For example, claim 6 recites “[t]he device of claim 5, further comprising respective lensing at each of the three positions.” Thus, contrary to Plaintiff’s construction, the claims indicate that the lensings and the reading head are claimed as separate structures. Moreover, dependent claims 5, 6, and 37 require the reading head to rotate to three positions. The claims further require that a lensing be “at” each of those three positions. The lensings cannot be part of the reading head and also, at the same time, be located “at” each of the three positions to which the reading head rotates. The Court finds that Plaintiff’s proposal is contrary to the intrinsic evidence and is directed at construing the claim so

that it reads on the accused device. *Source Vagabond Sys. Ltd. v. Hydrapak, Inc.*, 753 F.3d 1291, 1299–1300 (Fed. Cir. 2014) (“[A]n ‘analysis’ that adds words to the claim language without support in the intrinsic evidence in order to support a claim of infringement does not follow standard canons of claim construction.”) (internal quotations omitted).

Regarding Defendants’ proposal that the reading head has a single sensor, the Court agrees. The specification states that an example of the recited “reading head” includes “a camera or infra-red optical reading head (*e.g.* laser diode), suitable for capturing data and/or images.” ’950 Patent at 5:38–40. The specification further states that the reading head in Figure 6 is “a camera 2 which is mounted on a rotational printed circuit board (PCB) 91 centrally located on a pivotal axis 98.” *Id.* at 10:36–38. Likewise, claim 2 recites that the device of claim 1, wherein the reading head is a camera. Thus, a person of ordinary skill in the art would understand that the “reading head” may include a camera. Indeed, Plaintiff equates the “reading head” to the camera throughout its briefing.

The specification further states that “[i]n a preferred embodiment of the device the camera 2 will include an integrated image sensing array and associated signal processing circuitry with all the necessary support circuitry to produce a fully functional camera delivering a fully formatted composite video signal and automatic exposure control. ... An example of such a camera is the VVL1063 miniature monochrome on chip camera.” *Id.* at 7:51–61. This indicates that a person of ordinary skill in the art would understand that the “reading head” has a single sensor. In the embodiment disclosed in the specification, the “reading head” is a “camera” that has a single image sensing array.

Plaintiff fails to supply any intrinsic evidence to support its argument that a “camera” can have multiple lensings and/or multiple sensors. (Dkt. No. 217 at 29.) Instead, Plaintiff relies

exclusively on extrinsic evidence and argues that U.S. Patent No. 6,288,742 (the “’742 Patent”) illustrates a digital video camera with at least two lensings and at least two image sensors. (*Id.* (citing Dkt. No. 217-26).) The title of the ’742 Patent explicitly states that it is directed to “Video Camera Including Multiple Image Sensors.” Consistent with its title, the ’742 Patent specification discloses a dual lens digital camera that includes two image sensors. ’742 at 3:26-29. This is not surprising because a dual lens camera is a “preferred embodiment of the present invention” of the ’742 Patent.

However, unlike the ’742 Patent, there is no mention of “multiple image sensors” in the intrinsic evidence regarding the ’950 Patent. Indeed, as discussed above, the specification indicates that the camera includes only one image sensing array. Accordingly, the Court finds that the extrinsic evidence is not consistent with the intrinsic evidence, and therefore should not be relied upon to construe the terms “camera” or “reading head.” *Phillips*, 415 F.3d at 1319 (“[E]xtrinsic evidence may be useful to the court, but it is unlikely to result in a reliable interpretation of patent claim scope unless considered in the context of the intrinsic evidence.”); *see also OSRAM GmbH v. Int’l Trade Comm’n*, 505 F.3d 1351, 1356 (Fed. Cir. 2007) (“The patent specification is the primary resource for determining how an invention would be understood by persons experienced in the field.”).

Finally, the Court rejects Plaintiff’s argument that the general rule that “a” means “one or more” applies to the “reading head” recited in claim 1, or the “camera” recited in claim 2. The claim language, the specification, and the prosecution history “‘evinced[] a clear intent’ to limit ‘a’ or ‘an’ to ‘one.’ ... [and] necessitate a departure from the rule.” *Baldwin Graphic Sys., Inc. v. Siebert, Inc.*, 512 F.3d 1338, 1342–43 (Fed. Cir. 2008) (internal citation omitted). First, claim 38 recites a first reading head (*i.e.*, a first camera) and a second reading head (*i.e.*, a second camera).

This indicates that when the patentee intended to claim multiple reading heads (*e.g.*, multiple cameras), he did so explicitly.

Likewise, the specification consistently discloses a single reading head that can be placed in multiple positions. The specification describes “reading head 2, for example a camera or infra-red optical reading head (*e.g.* laser diode).” ’950 Patent at 5:38–40. The reading head may be contained within “clip-on enclosure 99.” *Id.* at 5:42–47. The specification describes that the reading head can be positioned to different viewing positions that correspond to different functions:

In a preferred embodiment of the invention, the hand held unit includes a three way semi-lockable rotational pivot and/or a rotational reflective mirror(s) and/or an electronically manipulated substrate, all of which can be electronically controlled and/or adjusted by an adjustable thumbwheel and/or keypad, either of which can both change the viewing position of the reading head and alter the primary function of the system. . . . Depending on the viewing position of the reading head the device is programmed to serve various primary functions.

Id. at 3:28–40; *see also id.* at 3:42–47 (describing “vertical” and “horizontal” positions). While each of these described embodiments uses a different mechanism to move the reading head between different positions, none describe more than one reading head, as Plaintiff proposes.

The remainder of the specification describes an embodiment where the “reading head 2” is embodied in “camera 2,” such as an “on chip camera,” which is contained within clip-on enclosure 99. *Id.* at 7:32–44, 7:51–61, 7:62–8:3, 10:35–38, 10:49–56, 14:5–9, Figure 6. The specification describes how the primary function of “camera 2” is altered by moving the camera between different positions through the use of the thumbwheel or a servo motor:

The position of the camera 2 can be adjusted via the thumbwheel 3 and/or a servo motor 65. The servo motor 65 is connected to the processor 41 via a servo controller 64. Consequently the user can alter the primary function of the Multiphone 20, as mention [sic] previously, via the thumbwheel 3 and/or the keypad 6. A more detailed discussion of the mechanical function of the servo

motor 65 and thumbwheel 3 will be given with reference to the clip-on enclosure 99, which is described later in FIG. 6.

Id. at 7:62–8:3. Figure 6 of the '950 Patent illustrates the type of reading head configuration that is recited in claim 1. The specification describes:

The clip-on enclosure 99 houses a camera 2 which is mounted on a rotational printed circuit board (PCB) 91 centrally located on a pivotal axis 98. . . . A servo motor 65 . . . can be used to rotate the rotational PCB 91 through 180° into three distinct functional positions. Additionally a thumbwheel connected to the main body of the Multiphone 20, can be used to rotate the rotational PCB 91 through the use of a gearing mechanism (not shown) which is incorporated into the clip-on enclosure. In each functional position, respective lensing 93, 94, and 95, incorporated in the lens body 96, assists in the correct focusing of the camera 2.

Id. at 10:36–48. In this embodiment, the multi-position reading head (camera 2) can rotate into three different positions corresponding to three different lensings (93, 94, and 95). This configuration is like the one recited in claim 1, which requires the multi-position, multi-function reading head (camera 2) to perform a first function when in a first position using a first lensing (rotated to face one of the lensings 93, 94, or 95) and to perform a second function when in a second position using a second lensing (rotated to face a different one of the lensings).

The prosecution history further indicates that the claim should be limited to one reading head. During prosecution, the patentee's arguments were prosecuted within the context of a single camera. In response to a rejection that included a tilt mechanism for a single camera, the patentee amended the claims and argued that the prior art failed to include a multi-positional reading head. The patentee added that since the prior art did not include a multi-positional reading head, "they necessarily lack the recited 'first lensing' and 'second lensing.'" (Dkt. No. 217-11 at 6.) In other words, the prior art lacked a single reading head that could make use of two different lensing located at two different position. This is exactly the claim amendment made by the patentee.

However, the Court finds that the scope of the claims do not necessarily exclude devices that have more than one reading head or more than one camera. Instead, the claims require that at least one “reading head” satisfies each of the recited limitations. In other words, claim 1 requires **“a single internal multi-function reading head that is physically moveable for producing an image signal when in a first position using a first lensing and for reading for image conversion using a second lensing when in a second position.”**⁹

2. Summary Judgment

In the Motions to Dismiss, the Moving Defendants argue that Plaintiff’s infringement theory, in light of the accused products, fails to state a claim upon which relief can be granted because it is implausible that the accused products have a “multi-position and multi-function

⁹ Statements made by the applicant during prosecution of the European counterpart to the ’950 further support the Court’s construction and foreclose Plaintiff’s claim construction arguments. See Prosecution History for European Patent No. 0875109, November 20, 2001 Communication to European Patent Office. During said prosecution, the applicant distinguished the claimed multi-position reading head from the camera disclosed in *Wilska*, noting that the latter camera in *Wilska* was “stationary” and it did not contain any teaching that “the camera uses different lensings in different positions as required by new claim 1.” *Id.* at 2/23. The applicant further noted that in the invention of the European Patent Claim 1, “[t]he use of multiple reading positions allows the reading head to be used for a variety of purposes, for example, in a first position the reading head allows the capture of the end user’s face . . . in a second position the reading head allows the user access to capture bar codes . . .” *Id.* at 3/23. Accordingly, in overcoming *Wilska*, the applicant explicitly characterized the invention of European Patent Claim 1 (corresponding to the asserted claim) as a single reading head as using at least two different lensings in different positions, performing a different function in each position. These statements further support the Court’s ultimate construction that requires at least one single reading head that is physically moveable between two positions using two lensings, and compels rejection of Plaintiff’s arguments to the contrary.

The Court is mindful that use of foreign prosecution history is disfavored in most contexts. However, such statements can be useful and probative to claim construction in narrow circumstances such as those presented here. For example, in *Apple Inc. v. Motorola, Inc.*, 757 F.3d 1286, 1312–1313 (Fed. Cir. 2014), the Federal Circuit considered statements made during the prosecution of a Japanese counterpart to be probative to the claim construction inquiry because the later prosecuted foreign counterpart (1) shared a familial relationship with the patent-in-suit claimed priority to the same PCT application; (2) shared the same specification; and (3) contained a claim identical to the construed claim. The Federal Circuit has also endorsed the use of statements made in foreign prosecutions where they constituted “blatant admissions” by the applicant directed at the relevant claims. *Gillette Co. v. Energizer Holdings, Inc.*, 405 F.3d 1367, 1374 (Fed. Cir. 2005). Use of the more detailed statements made by the applicant during the European prosecution directed to overcome a similar rejection is particularly appropriate here. The European application and the ’950 patent have the same specification, descend from the same PCT International Application, and the European claim and proposed amendment is nearly identical to same of the patent-in-suit. Under such circumstances, such statements have probative value relevant to the present claim construction inquiry.

reading head . . .” as claimed. Under Rule 56, such motions and supporting materials are properly addressed as a motion for a judgment of non-infringement. Having determined the proper construction of “an internal multi-position and multi-function reading head” of Claim 1 of the ’950 Patent is “a single internal multi-function reading head that is physically moveable where the reading head has a single sensor,” the Court now turns next to the question of whether there is a genuine issue of material fact and in turn, whether a reasonable jury could find that the Accused Products contains the properly construed limitation, either literally or through the doctrine of equivalents.

a. Legal Standards

Summary judgment is appropriate when “there is no genuine issue as to any material fact” and thus “the moving party is entitled to judgment as a matter of law.” Fed. R. Civ. P. 56(c). The court must draw all reasonable inferences in favor of the non-moving party. *See Masson v. New Yorker Magazine, Inc.*, 501 U.S. 496, 520, 111 S.Ct. 2419, 115 L.Ed.2d 447 (1991); *see also Matsushita Elec. Indus. Co. v. Zenith Radio*, 475 U.S. 574, 588 (1986). However, the opposing party “must do more than simply show that there is some metaphysical doubt as to the material facts.” *See Matsushita*, 475 U.S. at 588. “Where the record taken as a whole could not lead a rational trier of fact to find for the non-moving party, there is no ‘genuine issue for trial’ ” and summary judgment is thus warranted. *See Matsushita*, 475 U.S. at 587. Thus, the existence of a mere scintilla of evidence in support of the opposing party’s position will not prevent entry of summary judgment; there must be evidence on which the jury could reasonably find for the opposing party. *Anderson v. Liberty Lobby, Inc.*, 477 U.S. 242, 252 (1986)

Regarding patent infringement, “summary judgment of non-infringement is proper when

no reasonable jury could find that every limitation recited in a properly construed claim is found in the accused device either literally or under the doctrine of equivalents.” *Advanced Steel Recovery, LLC v. X-Body Equipment, Inc.*, 808 F.3d 1313 (Fed. Cir. 2015). “There can be no infringement as a matter of law if a claim limitation is totally missing from the accused device.” *London v. Carson Pirie Scott & Co.*, 946 F.2d 1534, 1538 (Fed. Cir. 1991). “Granting summary judgment of non-infringement prior to or early during fact discovery is highly unusual, “but entirely appropriate at an early stage in a case where . . . the issues are cut and dry,” *Famosa, Corp. v. Gaiam, Inc.*, No. 11 CIV. 5703 KBF, 2012 WL 573999, at *3 (S.D.N.Y. Feb. 22, 2012), and “only one conclusion as to infringement could be reached by a reasonable jury.” *TechSearch, L.L.C. v. Intel Corp.*, 286 F.3d 1360, 1369 (Fed. Cir.2002).

For example, in *Clark v. Walt Disney Co.*, 664 F. Supp. 2d 861 (S.D. Ohio 2009), the Court converted a motion to dismiss under 12(b)(6) to a motion for summary judgment of non-infringement. In *Clark*, the patent-in-suit covered an invention that allowed the user to activate a pre-recorded message by pushing a button attached to the surface of a poster. *Id.* at 863–64. The *Clark* plaintiffs alleged that Defendants infringed the ’272 Patents through its sale of Hannah Montana and Cheetah Girls Talking Posters. The *Clark* defendants moved under Federal Rule of Civil Procedure 12(b)(6) for failure to state a claim upon which relief can be granted and argued that *Clark* plaintiffs could not succeed on their patent infringement claim. *Id.* at 864. Specifically, the defendants argued that the accused talking posters could not infringe because the surface of the housing unit on such posters was not prepared with a “matching art which is substantially the same as that area of said poster art which appears on said portion of said poster that said housing covers when said housing is attached to said poster, such that said housing artistically blends in with the surrounding poster art that is not covered by said housing,” a

limitation of the asserted claims.

The *Clark* court converted the motions to dismiss into motions for summary judgment, gave notice to the parties of the same along with an opportunity to supplement the record, and, on that record, dismissed the claims. *Id.* at 864. First, the court construed the claim limitation at issue, holding that the claims unambiguously required that the artwork on the surface of the housing be substantially the identical to the artwork on the area of the posters it covers, so that the housing is camouflaged and the visual flow of the poster art is not interrupted. *Id.* at 871. Of note, the court noted that the language at issue, “wherein a surface of said housing is prepared with a matching art which is substantially the same as that area of said poster art . . .” had been added to overcome prior art which disclosed a display device containing the speakers in two separate pieces, in contrast to the invention of the ’272 patent which was a single piece. *Id.* Second, the court compared the construed claim to the accused product to determine if a reasonable juror could find that the accused posters infringed such claims, an inquiry that could be easily answered based on a superficial examination of the accused posters. Each of the nine accused posters consisted of a solid color bar running the entire width of the bottom of the poster, thereby interrupting the visual flow of the artwork directly underneath the color bar. *Id.* at 871–72. Therefore, since the “matching art . . .” limitation was conspicuously absent, it found that no reasonable juror could find that the accused posters literally infringed. The Court also rejected the plaintiff’s doctrine of equivalents argument as barred by prosecution history estoppel because the language at issue had been added to overcome prior art and the plaintiffs failed to overcome the *Festo* presumption accompanying such amendment. *Id.* at 872–73.

Similarly, in *Barron v. SCVNGR, Inc.*, 13-cv-40084, 2014 WL 3109966 (D. Mass July 7, 2014), the court granted summary judgment of non-infringement early in the case, prior to any

scheduling conference or discovery. The patent in that case, the '873 patent, entitled "Communication Through a Financial Services Network," described and claimed a methods for communicating a message from a sender to a recipient in possession of a unique identifier. Of note, each of the asserted claims required a "transaction terminal." The *Barron* plaintiff asserted that the user's cell phone having the LevelUp mobile application installed thereon could be the claimed transaction terminal as described by the '873 patent claims. A month after answering the complaint, SVNGR d/b/a/ LevelUp ("LevelUp") moved for summary judgment of non-infringement. LevelUp's motion addressed a single dispositive issue: it argued that the accused mobile phones could not serve as a transaction terminal and therefore the limitation "cause a message to be delivered to a transaction terminal" was absolutely missing. First, the court construed the term "transaction terminal" as "a device that communicates financial transaction information for authorization via a secure financial network." *Id.* at *2. Second, the Court concluded that under that construction no reasonable juror could conclude that the accused products infringed.

The *Barron* court explained that in the LevelUp system, merchants can install a LevelUp scanner which can read a two dimensional LevelUp barcode from a display on the user's phone. *Id.* at *2. In such configuration, The LevelUp scanner reads the barcode from the phone display and then sends the encoded information and the transaction amount entered by the merchant to a LevelUp server which retrieves the customer's stored account information and transmits the transaction for authorization. *Id.* Therefore, the user's cell phone as used in the LevelUp service could not function as a transaction terminal because unlike the LevelUp scanner it "never connects to a financial network or communicates transaction information." *Id.* at *3. Accordingly, while the service sent an emails or push notifications to the mobile phone, because the phone could not

be a transaction terminal. Likewise, the LevelUp scanner never receives a message to display to the user. Accordingly, the Court found as a matter of law that the LevelUp service did not infringe, and on appeal, the Federal Circuit summarily affirmed two days after oral argument. *See Barron v. SCVNGR, Inc.*, 595 Fed. App'x 988 (Fed. Cir. 2015)

The Court also finds that *Parallel Networks, LLC v. Abercrombie & Fitch*, No. 6:10-CV-111, 2011 WL 3609292, at *8 (E.D. Tex. Aug. 12, 2011), a case from this District, is particularly instructive. In that case, Plaintiff Parallel Networks, LLC brought suit against over 100 large retailer defendants alleging infringement of a single patent. The patent-in-suit, the '111 Patent, entitled "Method and Apparatus for Client-Server Communications Using a Limited Capability Client Over a Low Speed Communications Network," generally relates to a method and apparatus for client-server communication. *Id.* at *1. After a status conference to discuss the most efficient manner in which to handle the case, the Defendants requested an early claim construction and summary judgment hearing. *Id.* The Defendants contended that construction of three claim terms would be case dispositive for nearly all Defendants. *Id.*

The court agreed, held an early claim construction hearing on three claim terms, and subsequently granted summary judgment. The Court adopted the moving defendants' proposed construction for one of the three terms resulting in the dismissal of 99 out of the 112 defendants. The Court construed the claim limitation "[applet] dynamically generated by the server in response to the request" to mean "constructed at the server, by combining the requisite functionality with the necessary data, at the time of and response to the client request" and "generating [an executable applet] dynamically in response to the data request" to mean "constructing at the server, by combining the requisite functionality with the necessary data, at the time of and in response to the client request." *Id.* at *8. Both constructions required the accused instrumentalities to combine

the data and functionality at the server. *Id.* The patent “[taught] away from the necessity of multiple transmissions” by transmitting both functionality and the required data bundled in a single group. *Id.* at *9. By contrast, the moving defendants’ accused instrumentalities “function[ed] in the precise way taught away from by the patent” by including either the data or functionality in a link, rather than actual code, necessitating multiple transmissions (as opposed to a single transmission) between the server and the client to transmit the necessary parts of the applet. *Id.* at *10. Accordingly, the Court entered summary judgment of non-infringement and on appeal the Federal Circuit affirmed. *See Parallel Networks, LLC v. Abercrombie & Fitch Co.*, 704 F.3d 958, 967 (Fed. Cir. 2013).

The Court also finds *Raylon LLC v. Complus Data Innovations*, No. 6:09-CV-355, 2011 WL 1104175, at *1 (E.D. Tex. Mar. 23, 2011) *aff’d in part, vacated in part, remanded sub nom. Raylon, LLC v. Complus Data Innovations, Inc.*, 700 F.3d 1361 (Fed. Cir. 2012), another case from this District, to be particularly instructive and factually apposite. Raylon accused three Defendants of infringing the ’589 patent entitled “Identification Investigating and Ticket Issuing System.” The ’589 patent generally relates to handheld computers that read magnetic tapes on an identification card, display and transmits information, and print tickets. The day after filing its answer, two defendants filed motions for summary judgment. The Court initially denied the motions as premature, but Defendants re-urged their motions representing that the motions turned on construction of a single term, “display being pivotally mounted on said housing.” According to Defendants (and as discussed below, nearly identical to the case here), the “pivotally mounted” limitation could not be met because the displays on the accused products were indisputably fixed. *Id.* at *4.

Accordingly, the Court granted leave and permitted summary judgment arguments at the claim construction hearing. The Court first construed “display being pivotally mounted on said housing” to mean “the display must be mounted on the housing so that the display and housing may pivot with respect to each other,” and then granted summary judgment of non-infringement because it was undisputed that each of the accused products had a fixed display screen. *Id.* at *5. The Court likewise rejected Raylon’s doctrine of equivalents argument because it would effectively read “pivotally” out of the claim and allow infringement by products functioning in a way “opposite” to what the claims require. *Id.* at *6.

As these cases demonstrate, early claim construction on a limited set of disputed terms followed by entry of summary judgment is appropriate if a superficial understanding of the accused products makes it clear that a single limitation is obviously absent from the accused products and that full blown discovery could not lead a reasonable jury to any other conclusion. Once the claims are properly construed, this case fits squarely within that genre. *See Ballard Med. Prods. v. Allegiance Healthcare Corp.*, 268 F.3d 1352, 1362 (Fed. Cir. 2001) (“Because there is no dispute over the structure of the accused device, resolution of the claim construction issue in this case dictates the outcome of the infringement inquiry.”).

b. Literal Infringement

A finding of no literal infringement follows directly from the claim construction analysis. The dispositive issue on summary judgment is whether the Moving Defendants’ accused instrumentalities contain at least one physically moveable camera.

Neither Plaintiff nor its expert argue that the Accused Products literally infringe under a construction requiring a single, physically moveable camera, (*see* Dkt. Nos. 233, 243, 243-1) and

no reasonable juror could conclude that they do. Each of the accused products has at least two distinct cameras—one front-facing and one rear-facing—each having a different sensor. For example, the Dell Venue 8 7000 Series tablet has four cameras: a front facing camera, a rear camera, and two rear depth cameras. (*See* Dkt. No. 234-12 at 2, Quintero Decl. ¶ 3(a). Such cameras are fixed. (*See* Dkt. No. 234-12 at 2–14 (stating that each camera in each accused Dell product is “fixed”); Dkt. No. 234-13 at 2–29 (stating that each camera in each accused Acer product is “fixed”)).¹⁰ Fixed cameras are not physically moveable. *Cf. Raylon*, 2011 WL 1104175, at *5 (E.D. Tex. Mar. 23, 2011) (fixed display screens are not pivotally mounted).

Accordingly, the accused products do not literally infringe Claim 1 because no accused product has a single “physically moveable” reading head as the Court’s construction requires.

c. Doctrine Of Equivalents

Plaintiff argues that even if the adopted construction of Claim 1 requires that the accused reading head have a single sensor and be physically moveable foreclosing literal infringement, the camera system of each of the Accused Products infringes the last element of Claim 1 of the ‘950 Patent under the Doctrine of Equivalents. (*See* Dkt. No. 233 at 11.)

“To support a finding of infringement under the [doctrine of equivalents], a patentee must

¹⁰ While only two Defendants submitted declarations stating that their products have only have “fixed” cameras, Plaintiff has represented that all of the accused “smartphones and tablets all work in materially the same way with respect to this claim element.” (Dkt. No. 217 at 8; *see also id.* at 5 (“All of the accused products work the same way”). Further, nothing cited by either party suggests the accused cameras in any of the products work differently than the fixed Dell or Acer cameras for the purposes of infringement, nor does Plaintiff address this issue in its responsive brief. Indeed, Plaintiff’s expert, Dr. Nigel Jones, opines that each of the accused products work in essentially the same way for purposes of assessing infringement, (*See* Dkt. No. 233 at 5–6, Jones Decl. at ¶ 12; Dkt. No. 241-1 at 5–7, Jones Decl. at ¶ 14–15 (describing and depicting Accused Products having “two image sensor systems”); *id.* at 10–11, Jones Decl. at ¶ 25 (“To determine the impact of a system with a physically movable sensor versus a system with a logically moveable system utilizing two fixed sensors . . .”); Dkt. No. 233 at 4 (“Mr. Jones performed his analysis and formed his opinions under both tests, comparing a system with a single physically moveable sensor to a logically moveable system utilizing two fixed sensors (i.e., the Accused Products”). Accordingly, the Court properly deems the fact that all accused devices in this case have at least two *fixed* cameras to be uncontroverted.

either: (1) demonstrate an insubstantial difference between the claimed invention and the accused product or method; or (2) satisfy the function, way, result test.” *Fractus, S.A. v. Samsung Elecs. Co.*, 876 F. Supp. 2d 802, 819 (E.D. Tex. 2012) (citing *AquaTex Industries, Inc. v. Technische Solutions*, 479 F.3d 1320, 1326 (Fed. Cir. 2007)). Equivalence must be assessed as to the individual elements of the claimed invention, not to the invention as a whole. *Warner–Jenkinson Co. v. Hilton Davis Chem. Co.*, 520 U.S. 17, 29 (1997); *Freedman Seating Co. v. Am. Seating Co.*, 420 F.3d 1350, 1358 (Fed. Cir. 2005). According to the “triple identity test” or “function, way, result” test, an accused product will be deemed an equivalent if the missing element performs substantially the same function, in substantially the same way, with substantially the same result. *Graver Tank & Mfg. Co. v. Linde Air Prods. Co.*, 339 U.S. 605, 608 (1950). However, “the question of insubstantiality of the differences is inapplicable if a claim limitation is totally missing from the accused device.” *Eagle Comtronics, Inc. v. Arrow Commc’n Labs., Inc.*, 305 F.3d 1303, 1315 (Fed. Cir. 2002).

Prosecution history estoppel may foreclose a patent holder’s ability to rely on the doctrine of equivalents to prove infringement. *Warner–Jenkinson Co. v. Hilton Davis Chem. Co.*, 520 U.S. 17, 30 (1997). “Ordinarily, the doctrine of equivalents allows a patentee to claim, not only subject matter literally delineated by the claims, but also insubstantial alterations to the claims as written.” *GeoTag, Inc. v. Frontier Commc’ns Corp.*, No. 2:10-CV-00265-JRG, 2014 WL 282731, at *1 (E.D. Tex. Jan. 24, 2014) (citing *Festo Corp. v. Shoketsu Kinzoku Kogyo Kabushiki Co., Ltd.*, 535 U.S. 722, 733–34 (2002)). However, the doctrine of prosecution history estoppel prevents the patentee from using the doctrine of equivalents to recapture matter surrendered during patent prosecution. *AquaTex Indus.*, 479 F.3d at 1325; *see also Allen Eng’g Corp. v. Bartell Indus.*, 299 F.3d 1336, 1349–50 (Fed. Cir. 2002). Under *Festo Corp. v. Shoketsu Kinzoku Kogyo Kabushiki*

Co., 535 U.S. 722 (2002), a narrowing amendment to a claim creates a presumption that prosecution history bars a later equivalency by the patentee in an infringement action. “The burden of rebutting the *Festo* presumption lies with the patentee.” *Amgen Inc. v. Hoechst Marion Roussel, Inc.*, 457 F.3d 1293, 1312 (Fed. Cir. 2006); *GeoTag, Inc.*, 2014 WL 282731 at *2. The question of whether and to what extent prosecution history estoppel bars argument under the doctrine of equivalents is a question of law to be determined exclusively by the court. *Id.* at *1.

To overcome the *Festo* presumption of estoppel and recapture the ability to assert the doctrine of equivalents, the patentee must show either (1) the equivalent was unforeseeable at the time the claim was drafted; (2) the amendment did not surrender the particular equivalent in question; or (3) there was some reason why the patentee could not have recited the equivalent in the claim. *See Festo*, 535 U.S. at 740–41; *Festo Corp. v. Shoketsu Kinzoku Kogyo Kabushiki Co.*, 344 F.3d 1359, 1368–70 (Fed. Cir. 2003); *Rhodia Chimie v. PPG Indus. Inc.*, 402 F.3d 1371, 1382 (Fed. Cir. 2005). Here, the Court finds that none of these three grounds addressed in *Festo* and its progeny apply to overcome the presumption of estoppel.

Regarding foreseeability, independent claim 38 (which is not asserted in this lawsuit) demonstrates that a person of skill in the art could have foreseen and knew how to claim the alleged equivalent. Claim 38 claims a personal communication system comprising . . . a first interchangeable reading head . . . and a ***second interchangeable reading head.***” (emphasis added). Further, Plaintiffs own submissions clearly establish that the alleged equivalent was foreseeable. During claim construction, Plaintiff relied on prior art references as extrinsic evidence to support its position that the term “camera” can have multiple lensing and/or multiple sensors. As discussed *supra*, according to Plaintiff, U.S. Patent No. 6,288,742 to Ansari titled “Video camera including multiple sensors” illustrates a digital video camera with at least two lensings and at least

two image sensors. Ansari has a filing date of May 27, 1997 and a priority date of September 21, 1995. Ansari demonstrates that the alleged equivalent—a digital camera system comprising a plurality of sensors, each having a lens for capturing an image—was known in the prior art. The Ansari system includes a processing unit for processing the first electrical signal and the second electrical signal and a switch for selectively coupling either the first electrical signal or the second electrical signal to the processing unit. The reference further discloses that such a system was advantageous because there often occurs a need to switch camera views quickly from one room view to another or from face-to-face view to face-to-document view, in contrast to the then present methods for achieving these views with motor driven pan/tilt stages and and/or multiple cameras. Accordingly, Plaintiff cannot argue that the alleged equivalent was unforeseeable at the time of the amendment.

Next, the tangential relation grounds does not apply because the amendment was made to overcome prior art. As discussed *supra*, during prosecution, the examiner noted that the Wilska reference taught every element of Claim 1, except it did not explicitly disclose “an adjustable reading head.” The examiner found said limitation in the Boyd reference. (Dkt. No. 217-10 at 3–5.) Boyd discloses, among other things, a camera attached to a video teleconferencing unit with lens-tilt mechanism so that the lens can be manually adjusted without having to adjust the positioning of the entire teleconferencing unit. Subsequently, to distinguish the combination of these two references, the applicant amended the claim to include the “multi-position” language at issue which relate to the equivalents at issue in this case. (See Dkt. No. 217-11.) Therefore, the amendments can hardly be said to be merely tangential.

Finally, nothing in the prosecution history warrants application of the third grounds for overcoming the *Festo* presumption. There is no shortcoming of language to describe the alleged

equivalent. As explained above, Claim 38 demonstrates that a patent prosecutor could have easily described the proposed equivalent and further, that the alleged equivalent structure was described in the prior art.

The Court holds that Plaintiff's unavailable doctrine of equivalents argument also fails as a matter of law. No reasonable juror could find the accused camera system—the dual fixed front-facing and rear-facing cameras employing a software toggle—as equivalent to the single multi-positional camera recited in the claims. The way in which the claimed “reading head” performs the function of capturing image signals is significantly different from the way in which the accused products perform said function. Fundamentally, there are really only two ways to perform such image capturing function: using a single moveable camera with multiple lensings (as recited by the claims) or using multiple fixed cameras with multiple lensings. The multi-camera / software-toggling system, such as that used by the accused products, is essentially the “fundamental opposite” of the single, multi-positional and multi-functional camera recited in the claims. *Wleklinski v. Targus, Inc.*, 258 F. App'x 325, 329 (Fed. Cir. 2007) (“[T]he Targus strap, which has an auxiliary strap means composed of a single unitary material made of the same fabric, is the fundamental opposite of the claimed invention, in which the auxiliary strap means requires separate sections made of different materials.”); *see also Raylon, LLC v. Comluc Data Innovations, Inc.*, 700 F.3d 1361, 1367 (Fed. Cir. 2012) (affirming that “fixed” screens could not be equivalent to a display “pivotally mounted”); *Planet Bingo, LLC v. GameTech Int'l, Inc.*, 472 F.3d 1338, 1345 (Fed. Cir. 2006) (“This court has refused to apply the doctrine in other cases where the accused device contained the antithesis of the claimed structure.”); *Freedman Seating Co. v. Am. Seating Co.*, 420 F.3d 1350, 1361 (Fed. Cir. 2005) (opining that accused products with moveable end confined to a “fixed location” on a seatbase could not be equivalent to claim

limitation requiring “a moveable end slidably mounted to” a seatbase). A device with two fixed cameras, neither of which performs all of the claim limitations, cannot be said to operate in the same way as the claimed structure which requires a single physically moveable and multi-function reading head perform the claim limitations.

Accordingly, the accused products do not have an equivalent structure to the claimed multi-position and multi-function reading head. The doctrine of equivalents does not apply, as a matter of law.

III. Conclusion

In sum, the Court construes the phrase “**an internal multi-position and multi-function reading head**” to mean “**a single internal multi-function reading head that is physically moveable.**” The present record reflects that there is no material dispute none of the accused products have a physically moveable reading head, either literally or under the doctrine of equivalents. Therefore, for the reasons set forth herein, pursuant to Federal Rule of Civil Procedure 12(d), the Court **CONVERTS** the pending Motions to Dismiss into motions for summary judgment under Federal Rule of Civil Procedure 56 and, having done so, **DISMISSES** all claims against all Defendants **WITH PREJUDICE**.

So ORDERED and SIGNED this 2nd day of September, 2016.



RODNEY GILSTRAP
UNITED STATES DISTRICT JUDGE