

**IN THE UNITED STATES DISTRICT COURT  
FOR THE EASTERN DISTRICT OF TEXAS  
MARSHALL DIVISION**

TRAXXAS, L.P.,	§	
	§	
Plaintiff,	§	
	§	
v.	§	No. 2:16-CV-00768-JRG-RSP
	§	(lead case)
	§	
HOBBICO, INC., ET AL.,	§	
	§	
Defendants.	§	

**MEMORANDUM OPINION AND ORDER ON CLAIM CONSTRUCTION**

On July 27, 2017, the Court heard argument on the construction of the disputed claim terms in United States Patents 7,793,951 (the '951 Patent), 7,883,099 (the '099 Patent), 8,315,040 (the '040 Patent), 8,982,541 (the '541 Patent), 9,061,763 (the '763 Patent); and 9,221,539 (the '539 Patent) (collectively "the Asserted Patents"). The Court has considered the arguments made by the parties at the hearing and in their claim construction briefs. Dkt. Nos. 71, 79, & 81.<sup>1</sup> The Court has also considered the intrinsic evidence and made subsidiary factual findings about the extrinsic evidence. *See Phillips v. AWH Corp.*, 415 F.3d 1303, 1314 (Fed. Cir. 2005); *Teva Pharm. USA, Inc. v. Sandoz, Inc.*, 135 S. Ct. 831, 841 (2015). The Court issues this Memorandum and Order on Claim Construction in light of these considerations.

---

<sup>1</sup> Citations to the parties' filings are to the filing's number in the docket (Dkt. No.) and pin cites are to the page numbers assigned through ECF.

**TABLE OF CONTENTS**

I. BACKGROUND ..... 3

    A. The '951 and '099 Patents ..... 3

    B. The '040 and '541 Patents ..... 4

    C. The '763 and '539 Patents ..... 7

II. APPLICABLE LAW ..... 8

    A. Claim Construction ..... 8

    B. Definiteness Under 35 U.S.C. § 112, ¶ 2 (pre-AIA) / § 112(b) (AIA) ..... 11

III. CONSTRUCTION OF AGREED TERMS ..... 12

IV. CONSTRUCTION OF DISPUTED TERMS ..... 14

    A. “chassis” ..... 14

    B. “adjacent” ..... 23

    C. “mounted” ..... 27

    D. “electrically coupled” ..... 30

    E. “the first clamp surface is movable [] when the first enclosure member is uncoupled from the second enclosure member” ..... 34

    F. “one or more wires separated from immediate surroundings and preventing passage of contaminants past or between the one or more wires” ..... 38

    G. “one of more flexible surfaces” ..... 43

    H. “relatively farther” ..... 47

V. CONCLUSION ..... 50

## **I. BACKGROUND**

### **A. The '951 and '099 Patents**

The '951 Patent is titled "Integrated Center Point Steering Mechanism for a Model Vehicle." The '951 Patent was filed on February 6, 2006, and issued on September 14, 2010. The '099 Patent is titled "Vehicle Suspension for a Model Vehicle." The '099 Patent was filed on February 6, 2006, and issued on February 8, 2011. The '951 and '099 Patents relate generally to a steering mechanism and suspension system respectively, for model vehicles. *See* '951 Patent at Abstract<sup>2</sup>; '099 Patent at Abstract.<sup>3</sup> The '951 and '099 Patents share a substantially similar specification.

---

<sup>2</sup> The Abstract of the '951 Patent follows:

A steering mechanism for a model vehicle is provided, having one or more steering actuators, a steering control arm pivotally mounted for rotation relative to a model vehicle chassis, the steering control arm being coupled directly to at least two tie rods, each tie rod controlling the steering of at least one wheel of a vehicle, and each of the one or more steering actuators coupled to the steering control arm to rotate the control arm relative to the vehicle chassis.

<sup>3</sup> The Abstract of the '099 Patent follows:

A model vehicle suspension is provided, comprising a vehicle chassis, a spring for providing a supporting suspension force, one or more dampers for providing a damping suspension force, the dampers having an elongated shape, wherein the dampers are mounted on the chassis with a longitudinal axis substantially horizontal relative to the chassis and at least a first suspension member mounted to the chassis for supporting a vehicle wheel, the first suspension member being mounted for movement upwardly and downwardly at the location for supporting a vehicle wheel. A coupling mechanism for transmitting suspension forces from one or both of the spring and the one or more dampers to the first suspension member at the location for supporting a vehicle wheel is also provided, the coupling mechanism being configured to transmit suspension forces to the first suspension member, while allowing movement of the first suspension member at the point of supporting a wheel.

Claim 27 of the '951 Patent is an exemplary claim and recites the following elements (disputed term in italics):

27. A steering mechanism for a toy model vehicle, comprising:

a vehicle *chassis*;

a plurality of suspension arms, each supported on opposite sides of the *chassis* for substantially vertical pivotal movement relative to the *chassis*;

a plurality of wheels, wherein each of the wheels is supported by one of the suspension arms for steering the toy model vehicle;

a steering control arm pivotally supported on the *chassis* substantially on a *chassis* longitudinal centerline for substantially horizontal pivotal movement about an arm pivot axis relative to the *chassis*;

a plurality of tie rods coupled to the steering control arm for steering the plurality of wheels and extending in substantially opposite directions, each tie rod supported by the steering control arm for substantially vertical pivotal movement relative to the *chassis* and for inboard and outboard actuation by the steering control arm to steer the plurality of wheels; and

wherein the outboard end of the suspension arms each has a range of travel of at least about 1 cm. of vertical displacement; and

a transmission drive shaft rotatably coupled to at least one wheel for driving the at least one wheel of the toy model vehicle, the transmission drive shaft positioned above the steering control arm, relative to the *chassis*.

## **B. The '040 and '541 Patents**

The '040 and '541 Patents are titled "Protective Enclosure for Model Vehicle," and share a common specification. The '040 Patent was filed on October 16, 2007, and issued on November 20, 2012. The '541 Patent was filed on November 14, 2014, and issued on March 17, 2015. The

'040 and '541 Patents relate to an enclosure that protects radio controlled (RC) vehicle parts from contaminants by retaining its sealing properties while allowing conveyances (*e.g.*, wires) to pass from the inside to the outside of the enclosure. *See, e.g.*, '040 Patent at Abstract.<sup>4</sup> Figure 2 of the '040 Patent illustrates an exemplary embodiment of the claimed protective enclosure 100.

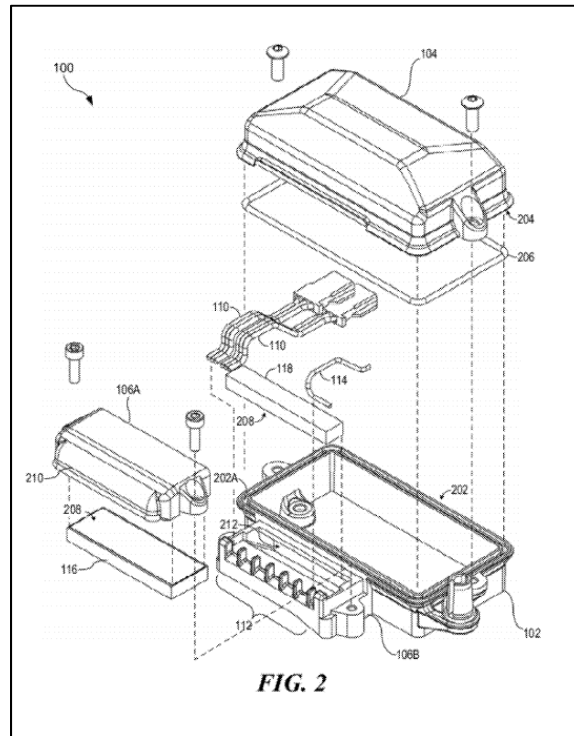

*Id.* at Fig. 2. The specification states that the enclosure includes a cover 104, a base 102, a clamp

<sup>4</sup> The Abstract of the '040 Patent follows:

The present invention provides for a protective enclosure comprising a base comprising a first continuous mating surface and at least one conveyance aperture, a cover comprising a second continuous mating surface, wherein the second continuous mating surface is configured to form a seal with the first continuous mating surface, and a clamp, wherein at least a portion of the clamp is coupleable to the base, wherein a mouth of the clamp is configured to be offset from the aperture when the clamp is coupled to the base, wherein the clamp comprises a first sealing layer, and wherein the clamp is configured to seal the aperture against contaminants. The protective enclosure may be configured for use in a remotely controllable model vehicle to protect a control module.

106 having a top portion 106a, a bottom portion 106b, and a mouth 108, through which conveyances such as ribbon cables 110 and wire 114 may traverse the enclosure. *Id.* at 2:21–25. The specification adds that base 102 of the enclosure comprises a conveyance aperture 212, which permits the conveyances to pass from the inside to the outside of the enclosure. *Id.* at 3:55–57. The specification further states the aperture is “configured to be offset” from the mouth of the clamp. *Id.* at 3:57–58.

The specification states clamp 106 may include flexible layers 116 and 118, which also form sealing layers. *Id.* at 3:9–10. The specification further states that “[w]hen assembled with ribbon cables 110 and wire 114 in place, flexible layers 116 and 118 compress and conform to the shapes and sizes of the transverse conveyances. For example, flexible layers 116 and 118 form a seal 119 to prevent contaminants from entering enclosure 100, even when ribbon cables 110 and wire 114 pass through mouth 108 of clamp 106.” *Id.* at 3:13–19.

Claim 1 of the ’541 Patent is an exemplary claim and recites the following elements (disputed term in italics):

1. A protective enclosure for a model vehicle component, comprising:
  - an enclosure comprising a first enclosure member and a second enclosure member, wherein the first and second enclosure members are coupleable together to form the enclosure;
  - at least one conveyance extending from inside the enclosure to outside the enclosure, wherein the at least one conveyance comprises *one or more wires separated from immediate surroundings and preventing passage of contaminants past or between the one or more wires* by electrical insulation material encasing the one or more wires;
  - a clamp comprising:
    - a first clamp surface and a second clamp surface;
    - wherein at least a portion of each of the first clamp surface

and the second clamp surface is configured to be positioned in a clamped position forming a clamp mouth around at least a portion of the at least one conveyance extending from inside to outside the enclosure, the clamp mouth restricting the passage of contaminants; and

wherein *the first clamp surface is movable* from the clamped position forming the clamp mouth to an unclamped position *relatively farther* from the second clamp surface releasing the at least one conveyance from the clamp mouth, *when the first enclosure member is uncoupled from the second enclosure member*; and

a first seal comprised of compressible sealing material having one or more flexible surfaces wherein the sealing material of the first seal is compressed between the first clamp surface and the second clamp surface, wherein the flexible surfaces of the first seal are configured to conform around at least a portion of opposite sides of the at least one conveyance within the clamp mouth when the first clamp surface is in the clamped position to restrict passage of contaminants into the enclosed space beyond the clamp mouth.

### **C. The '763 and '539 Patents**

The '763 and '539 Patents are titled “Rotorcraft with Integrated Light Pipe Support Members,” and share a common specification. The '763 Patent was filed on August 15, 2014, and issued on June 23, 2015. The '539 Patent was filed on November 14, 2014, and issued on December 29, 2015. The '763 and '539 Patents relate generally to propeller-driven remote-controlled flying vehicles, commonly known as rotorcraft or drones, with features directed at increasing structural stability, increasing rotorcraft visibility, and orientation awareness. *See, e.g., '763 Patent at Abstract.*<sup>5</sup>

---

<sup>5</sup> The Abstract of the '763 Patent follows:

A radio controlled model rotorcraft implemented with features improving ease of

Claim 1 of the '539 Patent is an exemplary claim and recites the following elements (disputed term in italics):

1. A radio controlled model rotorcraft having an electronics compartment, the model rotorcraft comprising:
  - a circuit board;
  - at least one light source *electrically coupled* to the circuit board;
  - and
  - a housing, the housing comprising:
    - a first frame;
    - a second frame removably coupled to the first frame; and one or more housing inner surfaces;wherein the circuit board is *mounted* to the first frame and the second frame by the at least one light source;
- wherein the circuit board is disposed within the housing *spaced apart from each housing inner surface*; and
- at least one rotor assembly, the at least one rotor assembly comprising at least one arm extending from the housing and at least one rotorcraft component.

## II. APPLICABLE LAW

### A. Claim Construction

“It is a ‘bedrock principle’ of patent law that ‘the claims of a patent define the invention to which the patentee is entitled the right to exclude.’” *Phillips v. AWH Corp.*, 415 F.3d 1303, 1312 (Fed. Cir. 2005) (en banc) (quoting *Innova/Pure Water Inc. v. Safari Water Filtration Sys., Inc.*, 381 F.3d 1111, 1115 (Fed. Cir. 2004)). To determine the meaning of the claims, courts start by

---

flight and flight performance by increasing structural stability, increasing rotorcraft visibility and orientation awareness through the use of multifunctioning, configurable, and aesthetically pleasing components, while also increasing resistance to damage from crashes through use of impact and vibration absorbing components.



considering the intrinsic evidence. *Id.* at 1313; *C.R. Bard, Inc. v. U.S. Surgical Corp.*, 388 F.3d 858, 861 (Fed. Cir. 2004); *Bell Atl. Network Servs., Inc. v. Covad Commc’ns Group, Inc.*, 262 F.3d 1258, 1267 (Fed. Cir. 2001). The intrinsic evidence includes the claims themselves, the specification, and the prosecution history. *Phillips*, 415 F.3d at 1314; *C.R. Bard, Inc.*, 388 F.3d at 861. The general rule—subject to certain specific exceptions discussed *infra*—is that each claim term is construed according to its ordinary and accustomed meaning as understood by one of ordinary skill in the art at the time of the invention in the context of the patent. *Phillips*, 415 F.3d at 1312–13; *Alloc, Inc. v. Int’l Trade Comm’n*, 342 F.3d 1361, 1368 (Fed. Cir. 2003); *Azure Networks, LLC v. CSR PLC*, 771 F.3d 1336, 1347 (Fed. Cir. 2014) (“There is a heavy presumption that claim terms carry their accustomed meaning in the relevant community at the relevant time.”) (vacated on other grounds).

“The claim construction inquiry . . . begins and ends in all cases with the actual words of the claim.” *Renishaw PLC v. Marposs Societa’ per Azioni*, 158 F.3d 1243, 1248 (Fed. Cir. 1998). “[I]n all aspects of claim construction, ‘the name of the game is the claim.’” *Apple Inc. v. Motorola, Inc.*, 757 F.3d 1286, 1298 (Fed. Cir. 2014) (quoting *In re Hiniker Co.*, 150 F.3d 1362, 1369 (Fed. Cir. 1998)). First, a term’s context in the asserted claim can be instructive. *Phillips*, 415 F.3d at 1314. Other asserted or unasserted claims can also aid in determining the claim’s meaning, because claim terms are typically used consistently throughout the patent. *Id.* Differences among the claim terms can also assist in understanding a term’s meaning. *Id.* For example, when a dependent claim adds a limitation to an independent claim, it is presumed the independent claim does not include the limitation. *Id.* at 1314–15.

“[C]laims ‘must be read in view of the specification, of which they are a part.’” *Id.* (quoting *Markman v. Westview Instruments, Inc.*, 52 F.3d 967, 979 (Fed. Cir. 1995) (en banc)). “[T]he

specification ‘is always highly relevant to the claim construction analysis. Usually, it is dispositive; it is the single best guide to the meaning of a disputed term.’” *Id.* (quoting *Vitronics Corp. v. Conceptronic, Inc.*, 90 F.3d 1576, 1582 (Fed. Cir. 1996)); *Teleflex, Inc. v. Ficosa N. Am. Corp.*, 299 F.3d 1313, 1325 (Fed. Cir. 2002). But, “[a]lthough the specification may aid the court in interpreting the meaning of disputed claim language, particular embodiments and examples appearing in the specification will not generally be read into the claims.” *Comark Commc’ns, Inc. v. Harris Corp.*, 156 F.3d 1182, 1187 (Fed. Cir. 1998) (quoting *Constant v. Advanced Micro-Devices, Inc.*, 848 F.2d 1560, 1571 (Fed. Cir. 1988)); *see also Phillips*, 415 F.3d at 1323. “[I]t is improper to read limitations from a preferred embodiment described in the specification—even if it is the only embodiment—into the claims absent a clear indication in the intrinsic record that the patentee intended the claims to be so limited.” *Liebel-Flarsheim Co. v. Medrad, Inc.*, 358 F.3d 898, 913 (Fed. Cir. 2004).

The prosecution history is another tool to supply the proper context for claim construction because, like the specification, the prosecution history provides evidence of how the U.S. Patent and Trademark Office (PTO) and the inventor understood the patent. *Phillips*, 415 F.3d at 1317. However, “because the prosecution history represents an ongoing negotiation between the PTO and the applicant, rather than the final product of that negotiation, it often lacks the clarity of the specification and thus is less useful for claim construction purposes.” *Id.* at 1318; *see also Athletic Alternatives, Inc. v. Prince Mfg.*, 73 F.3d 1573, 1580 (Fed. Cir. 1996) (ambiguous prosecution history may be “unhelpful as an interpretive resource”).

Although extrinsic evidence can also be useful, it is “less significant than the intrinsic record in determining the legally operative meaning of claim language.” *Phillips*, 415 F.3d at 1317 (quoting *C.R. Bard, Inc.*, 388 F.3d at 862). Technical dictionaries and treatises may help a

court understand the underlying technology and the manner in which one skilled in the art might use claim terms, but technical dictionaries and treatises may provide definitions that are too broad or may not be indicative of how the term is used in the patent. *Id.* at 1318. Similarly, expert testimony may aid a court in understanding the underlying technology and determining the particular meaning of a term in the pertinent field, but an expert’s conclusory, unsupported assertions as to a term’s definition are entirely unhelpful to a court. *Id.* Generally, extrinsic evidence is “less reliable than the patent and its prosecution history in determining how to read claim terms.” *Id.* The Supreme Court recently explained the role of extrinsic evidence in claim construction:

In some cases, however, the district court will need to look beyond the patent’s intrinsic evidence and to consult extrinsic evidence in order to understand, for example, the background science or the meaning of a term in the relevant art during the relevant time period. *See, e.g., Seymour v. Osborne*, 11 Wall. 516, 546 (1871) (a patent may be “so interspersed with technical terms and terms of art that the testimony of scientific witnesses is indispensable to a correct understanding of its meaning”). In cases where those subsidiary facts are in dispute, courts will need to make subsidiary factual findings about that extrinsic evidence. These are the “evidentiary underpinnings” of claim construction that we discussed in *Markman*, and this subsidiary factfinding must be reviewed for clear error on appeal.

*Teva Pharm. USA, Inc. v. Sandoz, Inc.*, 135 S. Ct. 831, 841 (2015).

**B. Definiteness Under 35 U.S.C. § 112, ¶ 2 (pre-AIA) / § 112(b) (AIA)**

Patent claims must particularly point out and distinctly claim the subject matter regarded as the invention. 35 U.S.C. § 112, ¶ 2. A claim, when viewed in light of the intrinsic evidence, must “inform those skilled in the art about the scope of the invention with reasonable certainty.” *Nautilus Inc. v. Biosig Instruments, Inc.*, 134 S. Ct. 2120, 2129 (2014). If it does not, the claim fails § 112, ¶ 2 and is therefore invalid as indefinite. *Id.* at 2124. Whether a claim is indefinite is determined from the perspective of one of ordinary skill in the art as of the time the application for the patent was filed. *Id.* at 2130. As it is a challenge to the validity of a patent, the failure of any

claim in suit to comply with § 112 must be shown by clear and convincing evidence. *Id.* at 2130 n.10. “[I]ndefiniteness is a question of law and in effect part of claim construction.” *ePlus, Inc. v. Lawson Software, Inc.*, 700 F.3d 509, 517 (Fed. Cir. 2012).

### III. CONSTRUCTION OF AGREED TERMS

The parties agreed to the construction of the following phrase:

Claim Term/Phrase	Agreed Construction
offset from the conveyance aperture (’040 Patent, Claim 20)	displaced in any direction from the conveyance aperture
portion of one or more one or more (’763 Patent, Claim 17)	portion of one or more
second clamping (’040 Patent, Claim 31)	second clamping surface

Dkt. No. 64 at 2. In view of the parties’ agreement on the proper construction of the identified terms, the Court **ADOPTS** the parties’ agreed constructions.

During the claim construction hearing, the parties agreed to the construction of the following term:

Claim Term/Phrase	Agreed Construction
spaced apart from each housing inner surface, spaced apart from the inner surfaces of the first frame, spaced apart from each inner surface of the housing (’539 Patent, Claims 1, 21, 27)	spaced apart from and not contacting each housing inner surface
resiliently deformable material (’763 Patent, Claim 4)	flexible material capable of changing shape and returning to substantially the original shape, such as, for example, rubber, foam, and the like

Regarding the “**spaced apart**” phrases, the intrinsic evidence indicates the phrases should

be further clarified to mean “spaced apart from and not contacting each housing inner surface.” The phrases relate to how the recited circuit board is disposed within the housing. For example, claim 1 recites “wherein the circuit board is disposed within the housing spaced apart from each housing inner surface.” The specification states “[v]ibrationally isolating the controls components of the rotorcraft 1000 may provide the advantages of prolonging the useful life of the rotorcraft 1000 through increased crash damage resistance and may also improve rotorcraft control and stability during flight, *with the controls components protected from vibrations* that may affect data collected by controls components for use in flight control.” ’539 Patent at 18:24–30 (emphasis added).

To provide vibration isolation, the specification states “[t]he PCBA 506 [circuit board] may be operably coupled to both the first cover 502 and base 504 within the formed center pod assembly 500 *without the PCBA 506 contacting any portion of the interior surface of the center pod assembly 500.*” *Id.* at 18:11–14 (emphasis added), *see also, id.* at 18:3–6 (“In this configuration, the circuit board of the PCBA 506 may be coupled to the first cover 502 *without making contact with any internal surfaces of the first cover 502.*”) (emphasis added). Thus, the specification indicates “spaced apart” includes not contacting the housing inner surface to provide the advantage of vibration isolation.

The prosecution history further confirms “spaced apart” includes not contacting the housing inner surface. Claim 1 was amended to recite “wherein the circuit board is disposed within the housing spaced apart from each housing inner surface,” and claim 27 was amended to recite “wherein the circuit board is disposed within the housing and spaced apart from each inner surface of the housing.” (Dkt. No. 79-9 at 8, 16). The examiner’s reason for allowance explained the amendments. Specifically, the examiner stated the circuit board in Kuo “appears to be mounted

directly to the housing, as seen in fig. 4. A load path exist from the housing, through the posts and the LED lights, to the circuit board. . . . Kuo et al. fails to teach a circuit board disposed within the housing spaced apart from each housing inner surface.” (*Id.* at 17). Accordingly, the Court **ADOPTS** the parties’ agreed construction for the “**spaced apart**” phrases.

Regarding the term “**resiliently deformable material**,” the intrinsic evidence indicates the term should be construed to mean “flexible material capable of changing shape and returning to substantially the original shape, such as, for example, rubber, foam, and the like.” The specification of the ’763 Patent states “[t]he foot 143 may comprise an elastic and resiliently deformable material, such as rubber, foam, and the like.” ’763 Patent at 12:52–54. Similarly, the examiner provided an example of a “resiliently deformable” material by identifying a “soft rubber mat.” (Dkt. No. 79-14 at 7). The specification further indicates the resiliently deformable material increases “resistance to damage from crashes through use of impact and vibration absorbing components.” ’539 Patent at Abstract. Likewise, claim 4 of the ’763 Patent recites that the foot members are “disposed beneath the at least one motor, providing landing support and impact resistance to the at least one rotor assembly.” Accordingly, the Court **ADOPTS** the parties’ agreed construction for “**resiliently deformable material**.”

#### IV. CONSTRUCTION OF DISPUTED TERMS

The parties’ dispute focuses on the meaning and scope of eight terms/phrases in the Asserted Patents.

##### A. “chassis”

<u>Disputed Term</u>	<u>Plaintiff’s Proposal</u>	<u>Defendants’ Proposal</u>
chassis (’951 Patent, Claims 27, 43)	Plain and ordinary meaning Alternatively: “base frame”	a horizontally extending base frame of the vehicle that defines a

		longitudinal centerline for the vehicle and which provides a vertical reference for the spatial relationship between the transmission drive shaft and the steering control arm
chassis (’099 Patent, Claims 1, 2, 6, 7, 13)	Plain and ordinary meaning Alternatively: “base frame”	a horizontally extending base frame to which the wheel suspension spring and damper are mounted

### 1. The Parties’ Positions

The parties dispute whether “chassis” should be construed to mean “a horizontally extending base frame,” as Defendants propose. Defendants also argue “chassis” should be construed as defining “a longitudinal centerline for the vehicle and which provides a vertical reference for the spatial relationship between the transmission drive shaft and the steering control arm” for the ’951 Patent. For the ’099 Patent, Defendants argue “chassis” should be construed as the “frame to which the wheel suspension spring and damper are mounted.”

Plaintiff argues “chassis” has a well-known plain and ordinary meaning, *i.e.*, the “base frame” of a vehicle. (Dkt. No. 71 at 10) (citing Dkt. No. 71-1 at ¶ 30; Dkt. No. 71-8; Dkt. No. 71-9 at 112:21–25). Regarding Defendants’ constructions, Plaintiff first contends elements of their constructions are present in the claims, and repeating those limitations in the construction of “chassis” is redundant, unnecessary, and confusing. (Dkt. No. 71 at 12). Plaintiff also argues the claims of the ’951 Patent only require the chassis itself have a “chassis longitudinal centerline,” and do not require the chassis define “a longitudinal centerline for the vehicle,” as Defendants propose. (*Id.* at 13). Plaintiff further contends Defendants’ construction as to the ’099 Patent introduces a term “wheel suspension spring” that does not appear anywhere in that patent, and that it requires

a damper be mounted to the chassis. *Id.*

Plaintiff further argues each specification uses the term “chassis” in its plain and ordinary sense. (*Id.* at 14) (citing ’951 Patent at Abstract, 1:60–2:3, 2:11–13, 2:21–23, 2:38–49, 2:64–3:7, 3:10–13, 4:8–22, 4:33–40, 4:43–67, 5:24–26, 5:37–39, 5:45–48, 5:56–60, 6:59–62, 8:29–31, 8:34–37, 9:50–54, 10:6–9, 10:46–52, 11:14–16, 11:44–48, 14:60–61, 15:6–8, 21:6–8, 21:15–19, 21:23–27, 21:34–39, 21:49–53, 22:16–49, 22:58–23:17). Plaintiff contends that Defendants’ different constructions for the same term in two patents violates the principle that, “the same claim term in the same patent or related patents [typically] carries the same construed meaning.” (Dkt. No. 71 at 14) (citing *In re Rambus Inc.*, 694 F.3d 42, 48 (Fed. Cir. 2012)). Plaintiff also argues both the patentees and the examiner used “chassis” in its plain and ordinary sense, with no indication of any other meaning. (Dkt. No. 71 at 15) (citing Dkt. No. 71-10; Dkt. No. 71-11).

Defendants respond the specification and claims make clear “chassis” has a specific contextual meaning. (Dkt. No. 79 at 9). Regarding the ’951 Patent, Defendants argue it only discloses a horizontally extending base frame for the vehicle that provides an underlying support for the vehicle components in the vertical direction. (*Id.* at 10). Defendants contend the advantages of the horizontally extending base frame of the chassis for the ’951 Patent are confirmed in the specification. *Id.* (citing ’951 Patent at 22:19–24, 23:6–17, 1:50–57; Dkt. No. 79-2 at ¶¶ 30–32). Defendants further argue the arrangement of center channel 104 and the recitation of “chassis longitudinal centerline” in claims 27 and 43 of the ’951 Patent makes clear that the patentees intended to claim the chassis in terms of the illustrated horizontal embodiments of Figures 47A and 48. (Dkt. No. 79 at 11) (citing Dkt. No. 79-2 at ¶¶ 36–37; ’951 Patent at 25:46–54, 23:21–23, Fig. 47B).

Defendants further argue that the patentees distinguished claim 27 of the ’951 Patent over the prior art by asserting that the prior art failed to disclose “a pivoting steering control arm



mounted substantially on the chassis centerline.” (Dkt. No. 79 at 11–12) (citing Dkt. No. 79-2 at ¶¶ 46–48 and 51; Dkt. No. 79-5 at 13). According to Defendants, the recitation of “chassis longitudinal centerline” in context of the intrinsic record of the ’951 Patent confirms the patentees are claiming a horizontally extending chassis. (Dkt. No. 79 at 12). Defendants also argue the specification of the ’951 Patent only contemplates vertical support and discloses “flanges 302 to extend both upwardly and inwardly toward the center of the vehicle 1400, more tightly packaging the components on the chassis 300.” *Id.* (citing ’951 Patent at 22:35–38). Defendants contend the specification details chassis 300 supporting a number of vehicle components from below, as illustrated in Figure 47B. (Dkt. No. 79 at 13) (citing ’951 Patent at 22:39–57). Defendants conclude that a person of ordinary skill in the art would have understood the claim language confirming that the horizontally extending chassis provides a vertical reference point for the transmission drive shaft to be above the steering control arm. (Dkt. No. 79 at 13).

Defendants also argue that, in the final response before the application was allowed, the patentees amended claim 27 (original claim 28) to recite the positions of the drive shaft and steering control arm relative to the chassis. (Dkt. No. 79 at 13–14) (citing Dkt. No. 79-6 at 7, 14, 17, 21, 22). According to Defendants, the patentees expressly limited the invention to a horizontally oriented chassis that provides a “vertical reference for the spatial relationship between the transmission drive shaft and the steering control arm.” (Dkt. No. 79 at 14).

Regarding the ’099 Patent, Defendants argue it is related to the ’951 Patent, and claims priority to the same parent patent application. (Dkt. No. 79 at 14). Defendants contend the ’099 Patent discloses the identical horizontally extending chassis 300 discussed above and illustrated in Figures 47A–48 of the ’951 Patent. (Dkt. No. 79 at 14) (citing ’099 Patent at 22:33–23:38). According to Defendants, only a horizontal extending chassis is disclosed throughout the ’099 Patent,

and the patentees did not contemplate any alternate structure. (Dkt. No. 79 at 14) (citing Dkt. No. 79-2 at ¶¶ 57–61; '099 Patent at 5:58–66; 8:55–59). Defendants also argue the disclosed embodiments of Figures 56–58D of the '099 Patent show the wheel suspension spring and damper mounted to chassis 300. (Dkt. No. 79 at 14–15). Defendants contend this is consistent with the normal understanding of a person of ordinary skill in the art that “a horizontal chassis is held above an underlying surface (*i.e.*, a road or ground) by a spring and damper arrangement and wheels to provide a vertical frame of reference.” (Dkt. No. 79 at 15) (Dkt. No. 79-2 at ¶¶ 55–56).

Plaintiff replies the specifications explicitly contemplate that the chassis need not extend horizontally. (Dkt. No. 81 at 5) (citing '951 Patent at 22:19–24, 22:40–59). Plaintiff argues Figure 48 teaches: (1) “downwardly sloping” lateral walls; (2) flanges extending from those walls “at a substantially lower level relative to an underlying surface”; and (3) upward sloping of the flanges. (Dkt. No. 81 at 5–6) (citing '951 Patent at 22:40–59, Fig. 48). According to Plaintiff, neither the specification nor the prosecution history define “chassis” or disclaim any non-horizontal orientation. (Dkt. No. 81 at 6).

For the following reasons, the Court finds the term “**chassis**” should be construed to mean “**base-frame of a vehicle.**”

## 2. Analysis

The term “chassis” appears in asserted claims 27 and 43 of the '951 Patent, and asserted claims 1, 2, 6, 7, and 13 of the '099 Patent. The Court finds the term is used consistently in the claims and is intended to have the same general meaning in each claim. The intrinsic evidence indicates the chassis is the base frame that a number of components are mounted or secured to. For example, claim 1 of the '099 Patent states “the first spring is mounted to the toy model vehicle chassis,” and that “the first damper is mounted to the toy model vehicle chassis.” Claim 1 further

recites the first suspension member is “secured to the toy model vehicle chassis for supporting the first wheel.”

Similarly, the specification states “FIG. 1 is in isometric view of a portion of the vehicle showing an engine mount supporting an engine on a chassis.” ’951 Patent at 2:11–12. The specification also states “FIG. 43A is a plan view of a steering servo mounted on the right side of the chassis.” *Id.* at 4:33–34. The specification further describes Figure 48 as “a perspective view of a vehicle chassis.” *Id.* at 4:53.

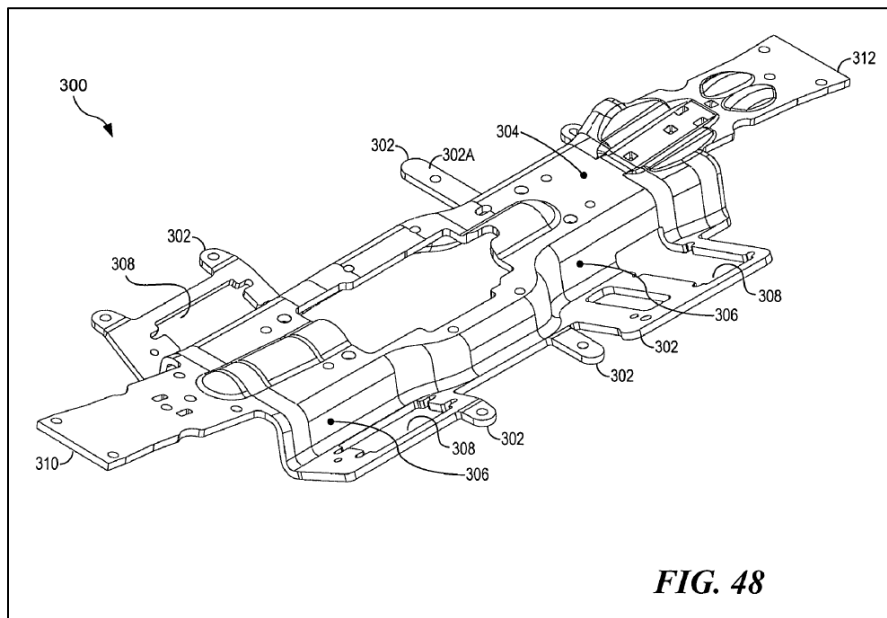

*Id.* at Fig. 48. The specification describes chassis 300 illustrated in Figure 48 as follows:

Referring now also to FIGS. 1 and 47A through 52, illustrated is a chassis 300, which is also described elsewhere in connection with other features and components comprising portions of the vehicle 1400. The chassis 300 is configured to provide a lower center of gravity than can typically be provided by conventional chasses resembling a relatively flat surface or plate. This is accomplished by providing chassis 300 with flanges 302 extending laterally from a central channel area 304. The lateral flanges 302 extend from downwardly sloping lateral walls 306 of the central channel area 304 at a substantially lower level relative to an underlying surface. The lateral flanges 302 provide support for relatively heavy components that do not require placement near or in alignment with the drive train of the

vehicle 1400. In general, the flanges 302 lower the mounting points of various components on the chassis 300, at least relative to the transmission assembly 520 and transmission output shaft 521. In addition, the flanges 302 preferably incline gradually as they extend laterally from the channel area 304. Upward sloping of the flanges 302 causes the components supported on the flanges 302 to extend both upwardly and inwardly toward the center of the vehicle 1400, more tightly packaging the components on the chassis 300.

*Id.* at 22:16–38. As indicated, the chassis is the base-frame to which a number of components are mounted to, secured to, or supported by. The specification indicates the chassis includes not only horizontal surfaces, but also includes vertical surfaces and is not a conventional chassis “resembling a relatively flat surface or plate.” *Id.*

The extrinsic evidence further confirms “chassis” should be construed to mean “base-frame of the vehicle.” The Dictionary of Mechanical Engineering, Society of Automotive Engineers (4th ed. 1996) defines “chassis” as “the base-frame of the vehicle.” (Dkt. No. 79-3 at 5). Moreover, Defendants’ expert, Steven Schmid, Ph.D., cited to this definition and opined that the term “chassis” is the “base frame” of a vehicle. *See, e.g.*, Dkt. No. 71-7 at ¶ 30 (“The term ‘chassis’ arises from the practice and art of vehicle design, where the chassis is the structural or base-frame of the vehicle”). During his deposition, Dr. Schmid indicated “chassis is a term of art that dates back to the 1700s. So I think it is something that’s been well understood by engineers for literally centuries.” Dkt. No. 71-9 at 112:21–25. Accordingly, the extrinsic evidence is consistent with the intrinsic evidence, and indicates a person of ordinary skill in the art would understand “chassis” to mean “base-frame of a vehicle.”

Defendants argue the ’951 Patent only discloses a horizontally extending base frame for the vehicle that provides an underlying support for the vehicle components in the vertical direction. (Dkt. No. 79 at 10). Defendants contend the advantages of the horizontally extending base frame

of the chassis for the '951 Patent are confirmed in the specification. *Id.* Contrary to Defendants' contention, the passage Defendants cite actually distinguishes the disclosed embodiment from "conventional chasses resembling a relatively flat surface or plate." '951 Patent at 22:19–24. As indicated above, the chassis illustrated in Figure 48 is not strictly a flat or horizontal surface. Instead, the specification illustrates the chassis with: (1) "downwardly sloping" lateral walls; (2) flanges extending from those walls "at a substantially lower level relative to an underlying surface"; and (3) upward sloping of the flanges. *Id.* at 22:16–38. Indeed, it is these non-horizontal surfaces that enable chassis 300 "to provide a lower center of gravity than can typically be provided by conventional chasses resembling a relatively flat surface or plate." *Id.* at 22:19–22.

Defendants further argue the patentees distinguished claim 27 over the prior art by asserting the prior art failed to disclose "a pivoting steering control arm mounted substantially on the chassis centerline." (Dkt. No. 79 at 11). The Court agrees the patentees distinguished the claims based on the prior art providing "for a steering action through the pivoting of arms 38 and 39, which are positioned away from the chassis centerline." (Dkt. No. 79-5 at 13). Indeed, the patentees explicitly amended claim 27 to recite "a steering control arm pivotally supported on the chassis substantially on a chassis longitudinal centerline." (Dkt. No. 79-5 at 7). Thus, the distinguishing feature is explicitly recited in the claims and does not support Defendants' argument the term should be construed as "a horizontally extending chassis." Accordingly, the Court finds neither the specification nor the prosecution history disclaim any non-horizontal orientation.

Defendants also contend that, in the final response before the application was allowed, the patentees amended claim 27 (original claim 28) to recite the positions of the drive shaft and steering control arm relative to the chassis. (Dkt. No. 79 at 13). Defendants note the patentees argued claims 27 and 43 (original claim 47) were allowable because "Figures 7 and 9 of Middlesworth

clearly show that the hydraulic motor 53, from which the drive shaft 109 extends . . . is below the steering control arm 99, relative to the chassis.” (Dkt. No. 79-6 at 14, 17, 21, and 22). The Court agrees. However, once again the claims explicitly recite the distinction argued for by the patentees. For example, claim 27 recites “the transmission drive shaft positioned above the steering control arm, relative to the chassis.” Thus, the distinguishing feature is explicitly recited in the claims, and does not support Defendants’ argument the phrase “vertical reference for the spatial relationship between the transmission drive shaft and the steering control arm” is required or should be included in the claims.

Regarding the ’099 Patent, Defendants argue the disclosed embodiments of Figures 56–58D of the ’099 Patent clearly show that wheel suspension spring and damper are mounted to chassis 300. (Dkt. No. 79 at 15). The Court agrees the embodiments in these figures show a wheel suspension spring and damper mounted to chassis 300. Indeed, claims 1 and 13 of the ’099 Patent each require that a spring be mounted on or to the chassis, and claim 1 of the ’099 Patent requires a damper be mounted to the chassis. However, claim 13 does not recite a damper mounted to the chassis. Thus, Defendants’ construction would read an unwarranted limitation into claim 13. Defendants’ construction also introduces a term “wheel suspension spring” that does not appear in the specification. Accordingly, the Court rejects Defendants’ construction.

In summary, Defendants’ constructions creates more confusion than clarity. A number of the elements of their constructions are present in the claims, and repeating those limitations in the construction of “chassis” is redundant, unnecessary, and confusing. For example, claims 27 and 43 of the ’951 Patent each require “a transmission drive shaft . . . positioned above the steering control arm, relative to the chassis.” Thus, the chassis necessarily “provides a vertical reference for the spatial relationship between the transmission drive shaft and the steering control arm.”

Additionally, claims 1 and 13 of the '099 Patent each require that a spring be mounted on or to the chassis. Finally, in reaching its conclusion, the Court has considered the extrinsic evidence submitted by the parties, and given it its proper weight in light of the intrinsic evidence.

**3. Court’s Construction**

The Court construes “**chassis**” to mean “**base-frame of a vehicle.**”

**B. “adjacent”**

<u>Disputed Term</u>	<u>Plaintiff’s Proposal</u>	<u>Defendants’ Proposal</u>
“adjacent”	Plain and ordinary meaning	“next to, and not within, and having no intervening structure between”

**1. The Parties’ Positions**

The parties dispute whether the term “adjacent” should be construed to mean “next to, and not within, and having no intervening structure between,” as Defendants propose. Plaintiff argues claims 1 and 16 are silent as to whether the light source may be “within” the first cover, or whether there may be an “intervening structure between” the light source and the first cover. (Dkt. No. 71 at 22). Plaintiff contends dependent claim 19 explicitly requires the light source to be disposed “at least partially within” the first cover, thereby narrowing claim 1, which explicitly requires the light source be disposed “adjacent” the first cover. *Id.* According to Plaintiff, “adjacent” necessarily includes “at least partially within.” *Id.* Plaintiff argues Defendants’ limitation “and not within” contradicts the language of the claims themselves. *Id.*

Plaintiff further argues the specification teaches an embodiment in which “LEDs may be provided as a light source and rubber, or plastic, O-rings may be provided as a locator . . . The O-ring may be stretched to fit over the LED and grip the LED along the O-ring inner surface, providing frictional resistance to removal of the placed O-ring.” (*Id.* at 23) (citing ’763 Patent at 16:48–

55). Plaintiff contends this arrangement results in an “intervening structure” (for example, O-ring 519D) between the light source (for example, LED 511D) and the first cover 502 (Dkt. No. 71 at 23) (citing ’573 Patent at Fig. 4). According to Plaintiff, this shows Defendants’ second limitation, “and having no intervening structure between,” is also inappropriate. (Dkt. No. 71 at 23).

Defendants respond the location of the light source(s) with respect to the first cover must be inferred from the drawings and other portions of the disclosure. (Dkt. No. 79 at 16) (citing ’763 Patent at 16:59–64, 17:28–35, Figure 12; Dkt. No. 79-2 at ¶ 66). According to Defendants, the light sources 511A-D in Figure 12 are adjacent to the first cover 502, and there is no structure intervening between each of the light sources 511A-D and the first cover 502. (Dkt. No. 79 at 17) (citing Dkt. No. 79-2 at ¶ 67). Defendants also argue the specification describes “the distance between the axis of rotation of adjacent propellers may be about 16.6 cm. (i.e., between propellers 104 and 204).” (Dkt. No. 79 at 17) (citing ’763 Patent at 3:34–39, Figures 1 and 2). Defendants contend Figure 1 illustrates propeller 104 adjacent to propeller 204, and there is no intervening structure between them. (Dkt. No. 79 at 17). Finally, Defendants argue their construction of “adjacent” is also consistent with the ordinary meaning of the term. (*Id.* at 18) (citing Dkt. No. 79-8 at 5; Dkt. No. 79-2 at ¶ 68).

Plaintiff replies “adjacent” necessarily includes, not excludes, “at least partially within” because dependent claim 19 requires the light source be disposed “at least partially within” the first cover. (Dkt. No. 81 at 7). Plaintiff also argues that the specification teaches O-ring locators as “intervening structures.” *Id.*

For the following reasons, the Court finds “**adjacent**” should be given its plain and ordinary meaning.



## 2. Analysis

The term “adjacent” appears in asserted claims 1 and 16 of the ’763 Patent. The Court finds that the term is used consistently in the claims and is intended to have the same general meaning in each claim. The Court rejects Defendants’ construction because it contradicts the intrinsic evidence. Independent claim 1 of the ’763 Patent recites “at least one light source disposed adjacent the first cover.” Dependent claim 16, which depends from claim 1, refers back to “the at least one light sources disposed adjacent the first cover.” Thus, claims 1 and 16 are silent as to whether the light source may be “within” the first cover or whether there may be an “intervening structure between” the light source and the first cover. However, dependent claim 19 recites “[t]he radio controlled model rotorcraft of claim 1, wherein *the at least one light source is disposed at least partially within the first cover.*” ’763 Patent at Claim 19 (emphasis added). Thus, dependent claim 19 narrows claim 1 and indicates “adjacent” necessarily includes and does not exclude “at least partially within.” *See, e.g., Trinity Indus., Inc. v. Rd. Sys., Inc.*, 121 F. Supp. 2d 1028, 1048 (E.D. Tex. 2000) (“A dependent claim includes all the limitations of the claim on which it depends, and thus, cannot be broader than the claim on which it depends”) (citing *Wahpeton Canvas Co. v. Frontier, Inc.*, 870 F.2d 1546, 1552 n.9 (Fed. Cir. 1989)).

The specification further indicates Defendants’ second limitation of “having no intervening structure between” is also inappropriate. For example, the specification teaches an embodiment in which “LEDs may be provided as a light source and rubber, or plastic, O-rings may be provided as a locator . . . The O-ring may be stretched to fit over the LED and grip the LED along the O-ring inner surface, providing frictional resistance to removal of the placed O-ring.” ’763 Patent at 16:48–55. As shown in Figure 4, this arrangement results in an “intervening structure” (for example, O-rings 519D) between the light source (for example, LED 511D) and the first cover 502.

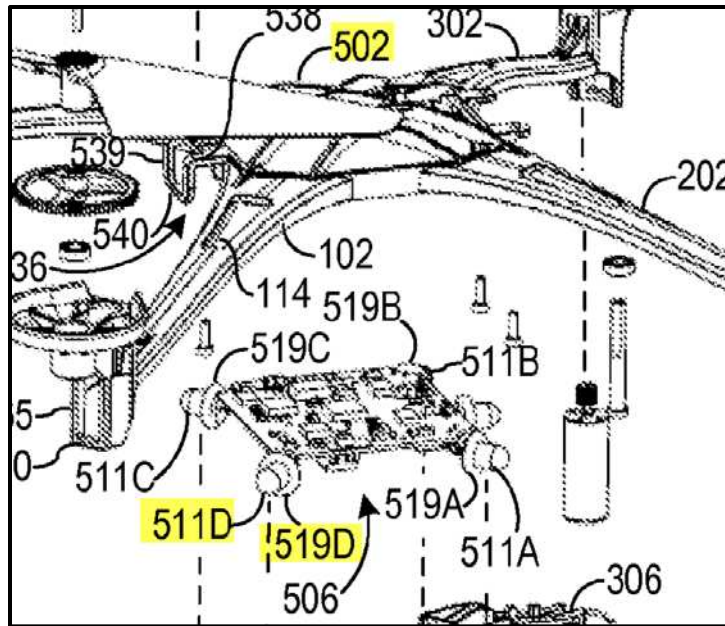

'763 Patent at Fig. 4 (highlighted, partial view). Defendants' Opposition Brief fails to address either of these arguments. Accordingly, the Court rejects Defendants' construction.

Defendants contend there is no explicit support for the disputed term in the specification, and therefore the location of the light source(s) with respect to the first cover *must be inferred* from the drawings and other portions of the disclosure. (Dkt. No. 79 at 16) (emphasis added). According to Defendants, the specification infers that “[w]hen the first cover 502 is coupled to the base 504, the light sources 511A-D are positioned next to the first cover 502, but not within the first cover 502, and there is no structure intervening between each of the light sources 511A-D and the first cover 502.” (Dkt. No. 79 at 16–17). As discussed above, Defendants' inference is contrary to the intrinsic evidence. Dependent claim 19 explicitly recites “[t]he radio controlled model rotorcraft of claim 1, wherein the at least one light source is disposed at least partially within the first cover.” Figure 4 further illustrates an “intervening structure” (for example, O-rings 519D) between the light source (for example, LED 511D) and the first cover 502.

Moreover, the use of “adjacent” elsewhere in the specification confirms the term should be given its plain and ordinary meaning. *See, e.g.*, ’763 Patent at 3:34–39. The Court agrees the disclosed “adjacent” propellers are next to, and not within one another, but this does not address the use of “adjacent” as it relates to the recited “light source” and “first cover.” Finally, in reaching its conclusion, the Court has considered the extrinsic evidence submitted by the parties, and given it its proper weight in light of the intrinsic evidence.

### 3. Court’s Construction

The term “**adjacent**” will be given its plain and ordinary meaning.

#### C. “mounted”

<u>Disputed Term</u>	<u>Plaintiff’s Proposal</u>	<u>Defendants’ Proposal</u>
mounted	Plain and ordinary meaning	securely affixed or fastened

#### 1. The Parties’ Positions

The parties dispute whether “mounted” should be construed as “securely affixed or fastened,” as Defendants contend. Plaintiff argues the term is well understood by a lay jury, and the Court is not required to construe every limitation. (Dkt. No. 71 at 26). Plaintiff contends the claim language surrounding the term is unremarkable and provides no reason to depart from the plain and ordinary claim language. (*Id.* at 27). Plaintiff further contends the specification and prosecution history uses the term in its ordinary sense. *Id.*

Defendants argue “mounted” is used to describe the relationship between the circuit board, the housing, and the light source. (Dkt. No. 79 at 21). Defendants contend the specification repeatedly uses the term “mounted” to describe structures that must be securely affixed or fastened together or else they would fall apart and not function properly. (*Id.* at 22) (citing Dkt. No. 79-2 at ¶ 80; ’539 Patent at 14:23–29, 14:32–34, 14:62–63). Defendants argue this concern is especially

true given that the '539 Patent relates to a rotorcraft. (Dkt. No. 79 at 22) (citing '539 Patent at 14:23–29, 14:32–34). Defendants also argue the patentees further clarified “mounted” means “securely affixed or fastened.” (Dkt. No. 79 at 22) (citing Dkt. No. 79-9 at 8, 9, 11, 12, 13, 18). Defendants contend their construction is consistent with the term’s ordinary meaning of “securely affixed or fastened.” (Dkt. No. 79 at 23) (citing Dkt. No. 79-2 at ¶ 79; Dkt. No. 79-11). Finally, Defendants argue their construction comports with how the Federal Circuit and other District Courts have interpreted the term in similar factual situations. (Dkt. No. 79 at 24).

Plaintiff replies that Defendants do not identify any difference between the scope of their construction and the scope of the term’s plain and ordinary meaning. (Dkt. No. 81 at 7). Plaintiff also argues Defendants misstate the prosecution history. (*Id.* at 8). Plaintiff contends the amendment was an examiner’s amendment in which the examiner largely rewrote all of the claims following a telephone interview. *Id.* According to Plaintiff, there is no indication the examiner or the patentees intended anything other than the plain and ordinary meaning of “mounted.” (*Id.*)

For the following reasons, the Court finds “**mounted**” should be given its plain and ordinary meaning.

## 2. Analysis

The term “mounted” appears in asserted claims 1, 2, 11, 12, and 21 of the '539 Patent. The Court finds the term is used consistently in the claims and is intended to have the same general meaning in each claim. The Court further finds the term is used in the claims to describe the relationship between the circuit board, the housing, and the light source. For example, claim 1 recites “wherein the circuit board is mounted to the first frame and the second frame by the at least one light source.” Claim 12 recites “wherein the circuit board is mounted to the first frame by the at least one first light source secured by the at least one first light securing surface,” and claim 21

recites “wherein the circuit board is mounted within the first frame by the at least one light source.” The specification further states “FIG. 13C is a cross-sectional view taken along line 13C-13C, the view showing a printed circuit board assembly (PCBA) mounted within a housing formed by a cover and base of a quadcopter rotorcraft.” ’539 Patent at 52:53–55. Simply stated, the intrinsic evidence indicates the circuit board is mounted to the frame by the light source. Given this context, the Court finds “mounted” is unambiguous, is easily understandable by a jury, and should be given its plain and ordinary meaning.

Defendants argue the specification repeatedly uses “mounted” to describe structures that must be securely affixed or fastened together, or else they would fall apart. (Dkt. No. 79 at 21–22). The Court agrees a propeller shaft and a propeller may be “securely affixed or fastened” to support rotation. However, the disputed term is used to describe the relationship between the circuit board, the housing, and the light source. The Court is not persuaded “mounted” should be redrafted as “securely affixed or fastened,” as Defendants contend. The claim language does not recite “fastened,” and there is nothing confusing with the term “mounted,” as it used in the claims. Mounted may include “securely affixed or fastened,” but there is nothing in the intrinsic evidence that indicates the term “mounted” should be redrafted as “securely affixed or fastened.” In sum, Defendants’ construction does not provide any additional context and could improperly limit the claims.

Defendants further argue the patentee disclaimed a circuit board that is merely within the housing, and that the ’539 Patent is limited to a circuit board securely affixed or fastened to or within the first frame/second frame/housing. (Dkt. No. 79 at 22–23). Specifically, Defendants contend the examiner stated Zhou disclosed “a UAV having a circuit board within a housing.” Defendants argue this required the patentee to amend claim 1 from “wherein the circuit board position

is at least partially fixed when the one or more locator members are received by the upper receptacles of the first cover” to “wherein the circuit board is mounted to the first frame and the second frame by the at least one light source.” (Dkt. No. 79 at 22) (citing Dkt. No. 79-9 at 8, 18).

The Court disagrees with Defendants’ characterization of the examiner’s reason for allowance. The examiner actually stated that “Zhou et al. (US 2014/0117149) teaches a UAV having a circuit board within a housing. It would not have been obvious to modify Zhou et al. with Kuo et al. to arrive at the claimed invention, because it would not have been obvious to mount the circuit board to the housing by the LED lights.” (Dkt. No. 79-9 at 18). Thus, the point of distinction was mounting the circuit board to the housing by the LED lights, which captured by the amendment to the claims. *See, e.g., Id.* at 8. Contrary to Defendants’ contention, this was not a clear and unambiguous disclaimer of a circuit board that is “merely within the housing.” As recited in the claims, the circuit board must be mounted to the frame by the at least one light source. Finally, in reaching its conclusion, the Court has considered the extrinsic evidence submitted by the parties, and given it its proper weight in light of the intrinsic evidence.

### 3. Court’s Construction

The term “**mounted**” will be given its plain and ordinary meaning.

#### D. “electrically coupled”

<u>Disputed Term</u>	<u>Plaintiff’s Proposal</u>	<u>Defendants’ Proposal</u>
electrically coupled	Plain and ordinary meaning Alternatively: “electrically connected”	rigid metal conductor electrically connecting the circuit board to the light source

#### 1. The Parties’ Positions

The parties dispute whether the term “electrically coupled” should be construed to include

“rigid metal conductor,” as Defendants propose. Plaintiff argues the claims use “electrically coupled” in its plain and ordinary sense. (Dkt. No. 71 at 24). Plaintiff further argues claim 27 uses the phrase “secured to” in addition to the phrase “electrically coupled.” *Id.* According to Plaintiff, this indicates the proper construction of “electrically coupled” does not necessarily include “secured to.” *Id.* Plaintiff also contends the specification makes clear the precise purpose of the “rigid metal conductor” is to “secure” the light source to the circuit board. *Id.* (citing ’539 Patent at 17:59–63).

Plaintiff also argues the passage cited by Defendants to support their construction contains permissive, not mandatory, language. (Dkt. No. 71 at 25) (citing ’539 Patent at 17:59–63). Plaintiff contends the prosecution history also supports its “plain and ordinary” construction. (Dkt. No. 71 at 25) (citing Dkt. No. 71-13 at 2, 4, 6, 22, 25, 26, 28, 29). According to Plaintiff, the prosecution history shows the patentees did not intend “electrically coupled” to encompass the “rigid coupling” limitation in the originally submitted claims. (Dkt. No. 71 at 26).

Defendants respond the specification’s disclosure of the ways to couple the light source to the circuit board support their construction. (Dkt. No. 79 at 27) (citing ’539 Patent at 17:53–62). Defendants argue a person of ordinary skill would understand “electrically coupled” means a “rigid metal conductor electrically connecting the circuit board to the light source.” (Dkt. No. 79 at 27) (citing Dkt. No. 79-2 at ¶¶ 91–94). Defendants contend Figure 12 demonstrates the coupling is (1) sufficient to form a rigid connection between the light source and the circuit board, and (2) sufficient to allow the light source to be the joining point for the circuit board to the frame. (Dkt. No. 79 at 27). Defendants argue Plaintiff seeks to broaden the coupling taught by the claims and described in the specification to be simply a connection. (*Id.* at 28).

Plaintiff replies it made clear that “ways to mount a circuit board within the vehicle using light sources” was an “example” of the Asserted Patents’ “means and methods for assembling such

vehicles to improve ease of flight and flight performance while enhancing the vehicles' appearance." (Dkt. No. 81 at 10) (citing '763 Patent at Abstract, 1:15–20, 1:65–2:6). Plaintiff contends the Court should construe "electrically coupled" in its broad, plain and ordinary sense. (Dkt. No. 81 at 10).

For the following reasons, the Court finds "**electrically coupled**" should be construed to mean "**electrically connected.**"

## 2. Analysis

"Electrically coupled" appears in asserted claims 1, 12, 21, and 27 of the '539 Patent. The Court finds the term is used consistently in the claims and is intended to have the same general meaning in each claim. The Court further finds the term should be construed to mean "electrically connected." As originally submitted, claim 1 of the application recited "one or more components configured to rigidly couple to the circuit board"; claim 12 of the application recited "wherein at least one light source is rigidly coupled to the circuit board"; and claim 21 of the application recited "wherein at least one light emitting diode is configured to electrically couple to the circuit board by a rigid coupling." (Dkt. No. 71-13 at 2, 4, 6). During prosecution, the examiner amended the claims and replaced the "one or more components configured to rigidly couple to the circuit board" with "at least one light source electrically coupled to the circuit board."

The examiner explained that "Zhou et al. (US 2014/0117149) teaches a UAV having a circuit board within a housing. It would not have been obvious to modify Zhou et al. with Kuo et al. to arrive at the claimed invention, because it would not have been obvious to mount the circuit board to the housing by the LED lights." (Dkt. No. 79-9 at 18). Thus, the point of distinction was mounting the circuit board to the housing by the LED lights, and not necessarily the rigidity of the



metal conductor. This is consistent with the specification, which describes the coupling of the light source to the circuit board as follows:

Referring to FIGS. 12 and 13C, the light sources 511A-E may couple to the PCBA 506 at locations along the perimeter of the PCBA 506. Referring to FIGS. 4, 12, and 13A-C, in a particular embodiment, *the light sources 511A-E may be implemented with locators 519A-E and sets of leads 526A-E for electrically coupling the light sources 511A-E to the PCBA 506.* Each set of leads 526A-E may comprise substantially rigid metal conductors, and may be soldered to the circuit board of the PCBA to create a substantially rigid connection between each light source 511A-E and the circuit boards.

'539 Patent at 17:53–62 (emphasis added). Accordingly, the Court finds “electrically coupled” should be construed to mean “electrically connected.”

The Court notes the portion of the specification quoted above also states the leads “may comprise substantially rigid metal conductors, and may be soldered to the circuit board of the PCBA to create a substantially rigid connection between each light source 511A–E and the circuit boards.” *Id.* However, as Plaintiff correctly argues, this passage contains permissive language, and does not indicate a clear intent of defining “electrically coupled,” as Defendants contend. Indeed, the “rigidly coupled” limitation was removed from the claims, and thus should not be read back into the claims.

Moreover, claim 27 recites the phrase “secured to,” in addition to “electrically coupled.” Specifically, claim 27 recites “at least one light source secured to and electrically coupled to the circuit board.” This weighs against Defendants’ construction by indicating “electrically coupled” refers to the electrical connection between the light source and circuit board, and does not necessarily require a “rigid metal conductor,” as Defendants propose. In sum, Defendants’ arguments are more appropriately directed to the “mounted” term, and not the “electrically coupled” term. Indeed, Defendants’ construction attempts to define how the light source is mounted to the circuit

board (*i.e.*, “a rigid conductor”). Finally, in reaching its conclusion, the Court has considered the extrinsic evidence submitted by the parties, and given it its proper weight in light of the intrinsic evidence.

### 3. Court’s Construction

The Court construes “**electrically coupled**” to mean “**electrically connected.**”

#### E. “the first clamp surface is movable [] when the first enclosure member is uncoupled from the second enclosure member”

<u>Disputed Term</u>	<u>Plaintiff’s Proposal</u>	<u>Defendants’ Proposal</u>
the first clamp surface is movable [] when the first enclosure member is uncoupled from the second enclosure member	Plain and ordinary meaning	first clamp surface can move independently of the uncoupled enclosure members

#### 1. The Parties’ Positions

The parties dispute whether the recited “first clamp surface” must move independently of the enclosure members, as Defendants propose. Plaintiff argues nothing in the claim prohibits the first clamp surface from being connected to the first enclosure member or prohibits the second clamp surface from being connected to the second enclosure member. (Dkt. No. 71 at 20). Plaintiff contends the specification explicitly states the first clamp surface may be connected to the first enclosure member and that the second clamp surface may be connected to the second enclosure member. (*Id.* at 20) (citing ’541 Patent at 2:38–47). According to Plaintiff, the specification explicitly includes scenarios in which the first clamp surface is not “independently movable.” (citing Dkt. No. 71 at 21).

Defendants respond their construction requires the first clamp surface to be separate from the enclosure members. Defendants argue the explicit language of claim 1 excludes an alternate

embodiment where the first clamp surface may be connected to the first enclosure member. (Dkt. No. 79 at 25). Defendants contend the claim language only recites that the first clamp surface is capable of being moved (*i.e.*, “moveable”) when the first enclosure member is uncoupled. (*Id.*) (Dkt. No. 79-2 at ¶ 86). According to Defendants, this means the uncoupling of the enclosure members is distinct from the movement of the clamp surfaces, and thus, the first clamp surface must be able to move independently of the first enclosure member. (Dkt. No. 79 at 25).

Defendants also argue Figure 2 of the ’541 Patent show a top portion 106a of clamp 106 and cover 104 are separate members. *Id.* (citing Dkt. No. 79-2 at ¶ 88). Defendants contend cover 104 and base 102 are coupled together by a first pair of screws, and the top clamp portion 106a and bottom clamp portion 106b are coupled together by a second, different pair of screws. (Dkt. No. 79 at 26). Defendants argue that when the base 102 and cover 104 are uncoupled, the clamping surfaces of clamp portions 106a, 106b remain in a clamped position and secured by the second pair of screws. *Id.* (citing Dkt. No. 79-2 at ¶ 89). According to Defendants, when the overlapping cover 104 is uncoupled from base 102 and the second set of screws are removed, then the clamping surface of the top clamp portion 106a can be moved (*i.e.*, “movable”) independently of the uncoupled cover 104 and base 102 to an unclamped position. (Dkt. No. 79 at 26) (citing Dkt. No. 79-2 at ¶ 90).

Plaintiff replies that nothing in the claims or the intrinsic evidence requires the first clamp surface 106a to move as soon as it is uncoupled. (Dkt. No. 81 at 9). Plaintiff argues Figure 2 of the ’541 Patent illustrates the use of screws to couple the first clamp surface 106a to the second clamp surface 106b. *Id.* Plaintiff contends that once those screws are removed (*i.e.*, the first clamp surface is “uncoupled”), the first clamp surface 106a is “movable” but does not necessarily “move.” *Id.*

Plaintiff argues that if the first clamp surface 106a were connected to the enclosure member, removing the screws (*i.e.*, uncoupling the first enclosure member from the second enclosure member) would make the first clamp surface 106a “movable,” but not necessarily “move” it. *Id.* (citing ’541 Patent at 2:38–47). According to Plaintiff, nothing prevents clamp portion 106a from being connected to cover 104, and there is no requirement that the clamp surface be movable independent from the enclosure member. (Dkt. No. 81 at 10).

For the following reasons, the Court finds **“the first clamp surface is movable [] when the first enclosure member is uncoupled from the second enclosure member”** should be given its plain and ordinary meaning.

## 2. Analysis

The phrase “the first clamp surface is movable [] when the first enclosure member is uncoupled from the second enclosure member” appears in asserted claim 1 of the ’541 Patent. The Court finds Defendants’ construction contradicts the claim language and embodiments disclosed in the specification. Claim 1 recites “an enclosure comprising a first enclosure member and a second enclosure member, wherein the first and second enclosure members are coupleable together to form the enclosure; . . . a first clamp surface and a second clamp surface; wherein at least a portion of each of the first clamp surface and the second clamp surface is configured to be positioned in a clamped position forming a clamp mouth around at least a portion of the at least one conveyance extending from inside to outside the enclosure . . . and wherein the first clamp surface is movable from the clamped position forming the clamp mouth to an unclamped position relatively farther from the second clamp surface releasing the at least one conveyance from the clamp mouth, *when the first enclosure member is uncoupled from the second enclosure member . . .*” ’541 Patent at Claim 1 (emphasis added).

As drafted, the claim does not indicate or require the first clamp surface to move independently of the uncoupled enclosure members. Instead, the claim indicates the first clamp surface is not required to move independently of the uncoupled enclosure members, because it requires uncoupling the first enclosure member from the second enclosure member as a condition of moving the first clamp surface from the clamped position. In other words, nothing in the claim prohibits the first clamp surface from being connected to the first enclosure member or prohibits the second clamp surface from being connected to the second enclosure member.

Moreover, the specification explicitly states the first clamp surface (for example, top portion 106a) may be connected to the first enclosure member (for example, cover 104), and that the second clamp surface (for example, bottom portion 106b) may be connected to the second enclosure member (for example, base 102). Specifically, the specification states the following:

It should be understood that enclosure 100 may comprise a single piece of material, in which, for example, clamp portions 106a and 106b are already connected to cover 104 and base 102, respectively, and cover 104 and base 102 are hinged. Alternatively, enclosure 100 may comprise multiple pieces, in which, for example, base 102, cover 104, top clamp portion 106a and bottom clamp portion 106b comprise separate portions that are coupleable, i.e. configured to be assembled together. The embodiment illustrated in FIG. 1, however, shows bottom clamp portion 106b and base 102 as a single piece to which cover 104 and top clamp portion 106a are coupleable.

'541 Patent at 2:38–44. Defendants contend the specification explicitly contemplates that the first clamp surface (106a) and the first enclosure member (104) are separate members that are independently movable. (Dkt. No. 79 at 25). Although this is one disclosed embodiment, Defendants do not address or even acknowledge that the specification also discloses an embodiment where the first enclosure member and first clamp are a single piece and would not “move independently.” Moreover, Defendants do not contend the intrinsic evidence indicates the patentees disclaimed the

single piece embodiment. Accordingly, the Court rejects Defendants’ construction because it excludes a disclosed embodiment from the scope of the claims. *Rambus Inc. v. Rea*, 731 F.3d 1248, 1253 (Fed. Cir. 2013) (“A claim construction that excludes the preferred embodiment ‘is rarely, if ever, correct and would require highly persuasive evidentiary support.’”) (quoting *Adams Respiratory Therapeutics, Inc. v. Perrigo Co.*, 616 F.3d 1283, 1290 (Fed. Cir. 2010)). Finally, in reaching its conclusion, the Court has considered the extrinsic evidence submitted by the parties, and given it its proper weight in light of the intrinsic evidence.

### 3. Court’s Construction

The phrase **“the first clamp surface is movable [] when the first enclosure member is uncoupled from the second enclosure member”** will be given its plain and ordinary meaning.

#### F. **“one or more wires separated from immediate surroundings and preventing passage of contaminants past or between the one or more wires”**

<u>Disputed Term</u>	<u>Plaintiff’s Proposal</u>	<u>Defendants’ Proposal</u>
one or more wires separated from immediate surroundings and preventing passage of contaminants past or between the one or more wires	plain and ordinary meaning	one or more separate and distinct wires, not including a bundle of wires, and preventing passage of contaminants between the one or more separate and distinct wires

#### 1. The Parties’ Positions

The parties dispute whether the “one or more wires” should be construed to mean “separate and distinct wires, not including a bundle of wires,” as Defendants propose. Plaintiff argues Defendants’ construction introduces ambiguity, potentially contradicts other claim language, and runs afoul of the prosecution history. (Dkt. No. 71 at 15). Plaintiff contends the plain and ordinary language of these claims is easy to understand, and requires each of the “one or more wires” be

encased by electrical insulation material that: (1) separates each wire from its immediate surroundings; and (2) prevents passage of contaminants past or between the one or more wires. (*Id.* at 16). Plaintiff further argues “bundle of wires” is ambiguous and can mean two intertwined threads of metal encased together by electrical insulation material, or it can mean a large group of insulated wires “bundled” together. *Id.* Plaintiff also contends Dr. Schmid’s testimony further underscores how Defendants’ proposed limitation of “not including a bundle of wires” contradicts the claim language. (*Id.* at 17) (citing Dkt. No. 71-9 at 185:8–20, 192:5–210).

Plaintiff further argues the shared specification of the ’040 and ’541 Patents uses “wires” in its ordinary sense. (Dkt. No. 71 at 17) (citing ’040 Patent at 1:9–32, 2:18–39, 2:50–3:28, 3:55–4:6, 4:27–35, 4:42–49). Plaintiff also contends the prosecution history does not disavow a “bundle of wires” from the claim scope. (Dkt. No. 71 at 17). Plaintiff argues the “one or more wires” phrase was added during prosecution of the ’040 Patent application to overcome a rejection based on U.S. Patent No. 6,602,089 (Abe). (*Id.* at 18) (citing Dkt. No. 71-12 at 3, 6). Plaintiff contends the patentees indicated “a single wire” may encompass a “bundle of wires.” (Dkt. No. 71 at 18) (citing Dkt. No. 71-12 at 5–6). According to Plaintiff, the prosecution history shows tubing 4d could have been the requisite “wire,” but the claims were patentable over Abe because remaining claim elements were not met. (Dkt. No. 71 at 19).

Defendants respond the patentees disclaimed that the “one or more wires” can be a bundle of wires. (Dkt. No. 79 at 29). Defendants contend the examiner noted in an Applicant-Initiated Interview Summary that “a proposed amendment was discussed that would appear to overcome the cited prior art by claiming that the flexible surfaces of the seal conform around at least a portion of opposite sides of a single wire of the at least one conveyance within the claim mouth.” *Id.* (citing Dkt. No. 79-12 at 3). Defendants also argue the patentees stated that a “[t]entative agreement was

reached that amending the claims to recite a seal with flexible surfaces that conform around at least a portion of opposite sides of a single wire, in combination with the other limitations of each respective claim, would patentably distinguish from the art currently of record.” (Dkt. No. 79 at 30) (citing Dkt. No. 79-13 at 11, 13–14). Defendants contend the statements made to overcome rejections based upon the prior art mean the patentees disavowed any such claim scope. (Dkt. No. 79 at 30) (citing Dkt. No. 79-2 at ¶ 97).

Plaintiff responds that the context of the prosecution history does not support Defendants attempt to invoke prosecution history estoppel to redefine “wire.” (Dkt. No. 81 at 10–11). Plaintiff contends the prosecution history focuses on the seal, such that the tubing encapsulating a “bundle” of wires is properly understood to be a “wire.” (*Id.* at 11) (citing Dkt. No. 79-13 at 13–14). According to Plaintiff, the “one or more wires” phrase should be given its plain and ordinary meaning. (Dkt. No. 81 at 11).

For the following reasons, the Court finds **“one or more wires separated from immediate surroundings and preventing passage of contaminants past or between the one or more wires”** should be given its plain and ordinary meaning.

## 2. Analysis

The phrase “one or more wires separated from immediate surroundings and preventing passage of contaminants past or between the one or more wires” appears in asserted claims 1 and 12 of the ’541 Patent; and asserted claim 20 of the ’040 Patent. The Court finds the phrase is used consistently in the claims and is intended to have the same general meaning in each claim. The dispute centers on arguments made by the patentees during prosecution. Specifically, the patentees argued the following:



Rejected independent Claim 28 as now amended more particularly recites one of the distinguishing characteristics of the present invention, namely the following:

the at least one conveyance comprises *one or more wires separated from immediate surroundings by electrical insulation material encasing the one or more wires*

\* \* \*

the flexible surfaces of the first seal are configured to conform around *at least a portion of opposite sides of the at least one conveyance* within the clamp mouth when the first clamp surface is in the clamped position." (Emphasis added.)

Dkt. No. 71-12 at 5 (emphasis in original). The patentees stated "Abe does not suggest, teach, or disclose a conveyance comprised of one or more wires separated from the immediate surrounding by electrical insulation encasing the one or more wires. Instead, Abe shows in Figure 2 . . . that the tubing 4d surrounds a bundle of loose wires." (*Id.* at 5–6). The patentees also summarized an examiner's interview by stating "[t]entative agreement was reached that amending the claims to recite a seal with flexible surfaces that conform around at least a portion of opposite sides of a single wire, in combination with the other limitations of each respective claim, would patentably distinguish from the art currently of record." (*Id.* at 3). Defendants contend the patentees' arguments and interview summary is a clear disclaimer of "one or more wires" being a bundle of wires. The Court disagrees.

As an initial matter, the Court does not agree with the patentees' argument that "Abe does not suggest, teach, or disclose a conveyance comprised of one or more wires separated from the immediate surrounding by electrical insulation encasing the one or more wires." (Dkt. No. 71-12 at 5–6). Abe states "[t]he cable 4a, 4a' in this invention is also referred to as a core wire, and may be a single conductor 4b or plural conductors 4b each covered with an insulating coating 4c or enamel material." U.S. Patent No. 6,602,089 (the '089 Patent) at 6:62–65. Abe further discloses "[t]he insulating coating 4c and tube 4d of the cable 4a, 4a' used in this invention may be made of

*e.g.* soft resin or rubber, etc. The wire or wire harness 4, which is composed of the cables 4a, 4a' and tube 4d, can be bent as necessary.” *Id.* at 10:50–54. Thus, Abe arguably discloses “one or more wires separated from immediate surroundings by electrical insulation material encasing the one or more wires.”

Notwithstanding, the distinction the patentees emphasized was that Abe failed to disclose the limitation of “the flexible surfaces of the first seal are configured to conform around at least a portion of opposite sides of the at least one conveyance within the clamp mouth when the first clamp surface is in the clamped position.” Specifically, the patentees argued “the tubing 4d surrounding the loose wires does not meet the claimed conveyance *and seal limitations*. *The tubing 4d does not conform around opposite sides of any single wire, as discussed with the Examiner in the Interview. And Abe does not show a first seal having flexible surfaces to conform around a portion of opposite sides of the tubing 4d.*” (Dkt. No. 71-12 at 6) (emphasis added). In other words, the patentees argued Abe failed to disclose the recited first seal, because if the loose wires (for example, 4a and 4a') were the “one or more wires,” then tubing 4d did not “conform around opposite sides” of any single wire; and, if tubing 4d were the wire, there were no flexible surfaces to conform around a portion of opposite sides of the tubing 4d.

This is not a clear and unambiguous disclaimer of “one or more wires” being a bundle of wires. *Omega Eng'g, Inc. v. Raytek Corp.*, 334 F.3d 1314, 1325–26 (Fed. Cir. 2003) (“[F]or prosecution disclaimer to attach, our precedent requires that the alleged disavowing actions or statements made during prosecution be both clear and unmistakable.”). For example, tubing 4d could have been the requisite “wire,” but the claims were patentable over Abe because the first seal limitation was not met. Defendants did not cite or mention this part of the patentees’ arguments in their briefing. Defendants also did not discuss how the patentees’ argument relate to the limitation

of “a first seal comprised of compressible sealing material having one or more flexible surfaces wherein the sealing material of the first seal is compressed between the first clamp surface and the second clamp surface, wherein the flexible surfaces of the first seal are configured to conform around at least a portion of opposite sides of the at least one conveyance within the clamp mouth when the first clamp surface is in the clamped position to restrict passage of contaminants into the enclosed space beyond the clamp mouth.” Accordingly, the Court finds the alleged disclaimer was captured by the amendments to the claims.

Moreover, Defendants’ construction contradicts and confuses the claim language. The claim language does not exclude a bundle of wires, but instead explicitly recites the conveyance includes “one or more wires.” In addition, the term “bundle of wires” is ambiguous, because it could mean two intertwined threads of metal encased together by electrical insulation material, or it can mean a large group of insulated wires “bundled” together. Finally, there is also no “separate and distinct” requirement recited in the intrinsic evidence. In sum, Defendants’ construction introduces unwarranted ambiguity into the claim language. Accordingly, the Court rejects Defendants’ construction. Finally, in reaching its conclusion, the Court has considered the extrinsic evidence submitted by the parties, and given it its proper weight in light of the intrinsic evidence.

### 3. Court’s Construction

The phrase **“one or more wires separated from immediate surroundings and preventing passage of contaminants past or between the one or more wires”** will be given its plain and ordinary meaning.

#### G. “one of more flexible surfaces”

<u>Disputed Term</u>	<u>Plaintiff’s Proposal</u>	<u>Defendants’ Proposal</u>
one of more flexible surfaces	one or more flexible surfaces	Indefinite for lack of antecedent basis

## 1. The Parties' Positions

The parties dispute whether the term “one of more flexible surfaces” is a typographical error that should be corrected by the Court. Plaintiff argues the context of the claims makes clear that “one of more flexible surfaces” refers to the “one or more flexible surfaces” recited in claim 1. (Dkt. No. 71 at 29–30). Plaintiff requests that the Court correct this typographical error by construing “one of more flexible surfaces” to mean “one or more flexible surfaces.” (*Id.* at 30). Plaintiff argues the correction from “of” to “or” is not subject to reasonable debate. *Id.* Plaintiff contends the claim language makes clear the “one of more flexible surfaces” in claim 2 is the “one or more flexible surfaces” in claim 1 by referring to each in the context of the “first seal.” *Id.* Plaintiff further argues the specification supports this interpretation by teaching that the same flexible layers 116 and 118 that form the first seal (as recited in claim 1) also “comprise deformable sealing material contacting opposite sides of the at least one conveyance” (as recited in claim 2). *Id.* (citing ’541 Patent at 3:29–32, 3:26–29). Plaintiff also argues the prosecution history does not suggest a different interpretation of “one of more flexible surfaces.” (Dkt. No. 71 at 31) (citing Dkt. No. 71-15 at 3).

Defendants respond the phrase “one of more flexible surfaces” lacks antecedent basis, and this incongruity in the claim renders it indefinite. (Dkt. No. 79 at 32). Defendants argue the claim recites the exact language submitted by the patentee during a claim amendment, and Plaintiff’s correction is subject to reasonable debate. (*Id.* at 33). Defendants contend the patentees included the “one of more flexible surfaces” language when it added claim 2 of the ’541 Patent. *Id.* (citing Dkt. No. 79-16 at 7). According to Defendants, the lack of antecedent basis is not correctable and the error renders claim 2 of the ’541 Patent indefinite under 35 U.S.C. § 112, second paragraph. (Dkt. No. 79 at 34).

Plaintiff replies that Defendants don't offer any other meaning that a person of ordinary skill in the art might give "one of more flexible surfaces." (Dkt. No. 81 at 12). Plaintiff argues the reference to the "first seal" in both claims removes any doubt that "one o[f] more flexible surfaces" is a typographical error well within this Court's province to correct. *Id.* Plaintiff requests that the Court correct "one of more flexible surfaces" in claim 2 of the '541 Patent to mean "one or more flexible surfaces," as recited in claim 1 of the '541 Patent. (*Id.* at 12).

For the following reasons, the Court finds "**one of more flexible surfaces**" should be corrected to "**one or more flexible surfaces.**"

## 2. Analysis

The phrase "one of more flexible surfaces" appears in asserted claim 2 of the '541 Patent. The Court agrees with the parties that the claim does not make sense as written. The Court further agrees the claim language should either be corrected or found invalid. The general rule regarding correcting claim language is that "[t]he district court can correct an error only if the error is evident from the face of the patent." *Group One, Ltd. v. Hallmark Cards, Inc.*, 407 F.3d 1297, 1303 (Fed. Cir. 2005). Two additional requirements must be met to permit correction: "(1) the correction is not subject to reasonable debate based on consideration of the claim language and the specification and (2) the prosecution history does not suggest a different interpretation of the claims." *Novo Indus., L.P. v. Micro Molds Corp.*, 350 F.3d 1348, 1357 (Fed. Cir. 2003). If these conditions are satisfied, then the patent should not be invalidated based on the error unless there is "evidence of culpability or intent to deceive by delaying formal correction." *Hoffer v. Microsoft Corp.*, 405 F.3d 1326, 1331 (Fed. Cir. 2005). The Court finds that all the requirements are met, and there is no evidence of culpability or intent to deceive.

First, the Court finds the mistake is evident from the face of the patent and is not subject to

reasonable debate based on the claim language and specification. Claim 1 of the '541 Patent recites “a first seal comprised of compressible sealing material having one or more flexible surfaces.” It is clear claim 2, which depends from claim 1, was intended to refer to the “one or more flexible surfaces” recited in claim 1. Indeed, dependent claims 6, 7, and 8, which also depend from claim 1, recite “the one or more flexible surfaces of the first seal.” The specification also describes “clamp 106 is also illustrated as comprising flexible layers 116 and 118, which also form sealing layers,” and that “flexible layers 116 and 118 form a seal 119 to prevent contaminants from entering enclosure 100, even when ribbon cables 110 and wire 114 pass through mouth 108 of clamp 106.” '541 Patent at 3:22–32. This is the “one or more flexible surfaces of the first seal” that was intended to be recited in dependent claim 2.

Second, nothing in the prosecution history suggests a different interpretation of the claims. The prosecution history indicates the error of “one of more flexible surfaces” occurred from the moment the claim was presented for examination. The patentees added dependent claim 12 as a new claim in the Preliminary Amendment filed on December 31, 2014. 76-17 at 7. Claim 12 recites the same language as claim 2, including the error of “one of more flexible surfaces.” Finally, there is no evidence before the Court of culpability or intent to deceive by delaying formal correction.

Defendants argue the claim recites the exact language submitted by the patentee during a claim amendment, and Plaintiff's correction is subject to reasonable debate. (Dkt. No. 79 at 33). The Court disagrees the correction is subject to reasonable debate or suggest a different interpretation. Defendants do not offer an alternative construction and provide no argument on what other interpretation the error could suggest. Moreover, that the error appears from the time the claim was added in the Preliminary Amendment further indicates it is an unintended error not subject to

reasonable debate. This is especially true given the other dependent claims correctly include “the one or more flexible surfaces of the first seal,” as discussed above.

### 3. Court’s Construction

The phrase “**one of more flexible surfaces**” is corrected to “**one or more flexible surfaces.**”

#### H. “relatively farther”

<u>Disputed Term</u>	<u>Plaintiff’s Proposal</u>	<u>Defendants’ Proposal</u>
relatively farther	Plain and ordinary meaning	Indefinite

#### 1. The Parties’ Positions

The parties dispute whether the term “relatively farther” is indefinite for failing to inform, with reasonable certainty, those skilled in the art about the scope of the invention. Defendants contend the ’541 Patent and the ’040 Patent provide no way of determining what distance, or level, is required to be “relatively farther” from the second clamp surface to allow a release of the conveyance. (Dkt. No. 79 at 34) (citing Dkt. No. 79-2 at ¶¶ 104–06). Defendants argue “relatively farther” appears only in the claims and there is no description in the specification or the file history to provide guidance. (Dkt. No. 79 at 35). Defendants further contend the claims are indefinite because the ’541 Patent and ’040 Patent fail to inform a person of ordinary skill in the art, with reasonable certainty, of the meaning of “relatively farther,” as used in the claims.

Plaintiff contends one need not be skilled in the art to understand the plain and ordinary meaning of this claim. (Dkt. No. 71 at 29). According to Plaintiff, the first clamp surface can move from a clamped position (which forms a clamp mouth as described earlier in each claim) to an unclamped position (in which the first clamp surface is relatively farther from the second clamp surface than it was in the clamped position), which movement from the clamped position to the

unclamped position releases the at least one conveyance from the clamp mouth. *Id.* Plaintiff argues the specification supports this reading. *Id.* (citing '541 Patent at 2:38–47). Plaintiff further argues Defendants do not offer any other reasonable interpretation of “relatively farther” that would render the phrase indefinite. (Dkt. No. 81 at 11). Plaintiff contends Defendants’ analysis is insufficient to meet their burden of proving indefiniteness by clear and convincing evidence. *Id.*

For the following reasons, the Court finds “**relatively farther**” is not indefinite and should be construed to mean “**apart.**”

## 2. Analysis

“Relatively farther” appears in asserted claim 1 of the '541 Patent, and asserted claim 20 of the '040 Patent. The Court finds the term is used consistently in the claims and is intended to have the same general meaning in each claim. The Court further finds the term is not indefinite. Claim 1 of the 541 Patent recites “a clamp comprising: a first clamp surface and a second clamp surface; wherein at least a portion of each of the first clamp surface and the second clamp surface is configured to be positioned in a clamped position forming a clamp mouth around at least a portion of the at least one conveyance extending from inside to outside the enclosure, the clamp mouth restricting the passage of contaminants; and wherein the first clamp surface is movable from the clamped position forming the clamp mouth to an unclamped position relatively farther from the second clamp surface releasing the at least one conveyance from the clamp mouth, when the first enclosure member is uncoupled from the second enclosure member.” Similarly, claim 20 of the '040 Patent recites “a clamp comprising: a first clamp surface and a second clamp surface; wherein at least a portion of each of the first clamp surface and the second clamp surface is configured to be positioned in a clamped position forming a clamp mouth around at least a portion of



the at least one conveyance extending through the conveyance aperture, the clamp mouth restricting the passage of contaminants; and wherein the first clamp surface is movable from the clamped position forming the clamp mouth to an unclamped position relatively farther from the second clamp surface releasing the at least one conveyance from the clamp mouth.”

Defendants contend there is no way of determining what distance, or level, is required to be “relatively farther” from the second clamp surface to allow a release of the conveyance. Contrary to Defendant’s contention, the claim language indicates the distance required to be “relatively farther” is met when the at least one conveyance is released from the clamp mouth. In other words, it is when the first clamp surface and the second clamp surface are no longer in the clamped position and are apart. The clamped position being the position that forms the recited clamp mouth, which restricts the passage of contaminants. The specification supports this reading. ’541 Patent at 3:29–32 (“For example, flexible layers 116 and 118 form a seal 119 to prevent contaminants from entering enclosure 100, even when ribbon cables 110 and wire 114 pass through mouth 108 of clamp 106.”).

Accordingly, the Court finds the claim language informs those skilled in the art about the scope of the claims with reasonable certainty. Defendants have failed to carry their burden of proving indefiniteness. Finally, in reaching its conclusion, the Court has considered the extrinsic evidence submitted by the parties, and given it its proper weight in light of the intrinsic evidence.

### **3. Court’s Construction**

The Court finds **“relatively farther”** is not indefinite and construes the term to mean **“apart.”**

**V. CONCLUSION**

The Court adopts the constructions above for the disputed and agreed terms of the Asserted Patents. Furthermore, the parties should ensure all testimony relates to the terms addressed in this Order is constrained by the Court's reasoning. However, in the presence of the jury the parties should not expressly or implicitly refer to each other's claim construction positions and should not expressly refer to any portion of this Order that is not an actual construction adopted by the Court. The references to the claim construction process should be limited to informing the jury of the constructions adopted by the Court.

**SIGNED this 29th day of September, 2017.**

  
ROY S. PAYNE  
UNITED STATES MAGISTRATE JUDGE