

**IN THE UNITED STATES DISTRICT COURT
FOR THE EASTERN DISTRICT OF TEXAS
MARSHALL DIVISION**

SEMCON IP INC.,	§	
	§	
<i>Plaintiff,</i>	§	
	§	
v.	§	
	§	
LOUIS VUITTON NORTH AMERICA, INC.,	§	CIVIL ACTION NO. 2:19-CV-00122-JRG (LEAD CASE)
	§	
TCT MOBILE INTERNATIONAL LIMITED, ET AL.,	§	CIVIL ACTION NO. 2:19-CV-00194-JRG (MEMBER CASE)
	§	
<i>Defendants.</i>	§	

CLAIM CONSTRUCTION MEMORANDUM OPINION AND ORDER

Before the Court is the opening claim construction brief of Semcon IP Inc. (“Plaintiff”) (Dkt. No. 47, filed on February 12, 2020),¹ the response of TCT Mobile International Limited (“Defendant”) (Dkt. No. 48, filed on February 26, 2020), and Plaintiff’s reply (Dkt. No. 49, filed on March 4, 2020). Having considered the arguments and evidence presented by the parties in their briefing, the Court issues this Order.

¹ Citations to the parties’ filings are to the filing’s number in the docket (Dkt. No.) and pin cites are to the page numbers assigned through ECF.

Table of Contents

I. BACKGROUND 3

II. LEGAL PRINCIPLES 6

 A. Claim Construction 6

 B. Departing from the Ordinary Meaning of a Claim Term..... 9

 C. Definiteness Under 35 U.S.C. § 112, ¶ 2 (pre-AIA) / § 112(b) (AIA) 10

 D. Previous Constructions of Disputed Terms 11

 D-1. Prior court constructions are entitled to reasoned deference. 11

 D-2. In some instances, a party may be estopped from pursuing a claim construction different from a prior court construction under the equitable doctrine of issue preclusion..... 11

III. AGREED CONSTRUCTIONS 12

IV. CONSTRUCTION OF DISPUTED TERMS..... 15

 A. “independently of instructions to be executed by the processor,”
 “independently of instructions to be executed by the central processor,”
 “determination made independently of instructions to be executed by the processor” and “determining step made independently of instructions to be executed by the central processor” 15

 B. “operating conditions of the central processor” 18

 C. “control software dedicated to a central processor” 21

 D. “operating characteristic” 24

 E. “sleep state” 28

 F. Order of Steps: ’061 Patent Claim 1 and ’247 Patent Claim 1 32

 G. “determining an allowable reduced power consumption level” and
 “determining a level of permitted power consumption” 36

 H. “a normal frequency and voltage” 38

 I. The Changing-the-Frequency-While-Execution-of-Instructions-is-Stopped
 Terms 43

 J. “said change in operating conditions” 47

 K. “sprint” 51

 L. “nominal operating frequency” and “nominal frequency of operation” 55

V. CONCLUSION 58

I. BACKGROUND

Plaintiff alleges infringement of four U.S. Patents: No. 7,100,061 (the “’061 Patent”), No. 7,596,708 (the “’708 Patent”), No. 8,566,627 (the “’627 Patent”), and No. 8,806,247 (the “’247 Patent”) (collectively, the “Asserted Patents”). These patents are related through a series of continuation applications and all ultimately claim priority to the application that issued as the ’061 Patent, which was filed on January 18, 2000. The ’061 Patent was subject to an inter partes reexamination requested on June 13, 2007 and from which a certificate issued on August 4, 2009.

The Court previously construed terms of the Asserted Patents in the following opinions:

- Claim Construction Memorandum Opinion and Order, *Semcon IP Inc. v. Huawei Device USA Inc. et al.*, No. 2:16-cv-00437-JRG-RSP, Dkt No. 172 (E.D. Tex. July 12, 2017) (“*Huawei*”),
- Claim Construction Memorandum Opinion and Order, *Semcon IP Inc. v. Amazon.com, Inc.*, No. 2:18-cv-00192-JRG, Dkt. No. 59 (E.D. Tex. May 13, 2019) (“*Amazon.com*”),
- Claim Construction Memorandum Opinion and Order, *Semcon IP Inc. v. ASUSTeK Computer, Inc. et al.*, No. 2:18-cv-00193-JRG, Dkt. No. 68 (E.D. Tex. July 10, 2019) (“*ASUSTeK*”), and
- Claim Construction Memorandum Opinion and Order, *Semcon IP Inc. v. Kyocera Corporation*, No. 2:18-cv-00197-JRG, Dkt. No. 65 (E.D. Tex. Aug. 22, 2019) (“*Kyocera*”).

The Asserted Patents are generally directed to technology for managing a computer system’s power consumption by dynamically adjusting the processor’s operating frequency and voltage. The technology of the patents may be generally understood with reference to Figure 1 of the ’061 Patent, produced below and annotated by the Court. A frequency generator (17) receives an external or “slow” clock (green) and from that generates a processor or “core” clock (purple) for operating the processor’s processing unit (16). The generator (17) also provides other clocks for various system-memory and other components. ’061 Patent col.3 ll.18–26. As shown in the figure, a voltage generator (12) that is connected to a power supply (13) provides a voltage (blue) to the processor’s processing unit 16. *See id.* at col.2 ll.46–57. The processor’s power consumption and operability are related to the voltage and core-clock frequency. *See, e.g., id.* at col.1 ll.39–47, col.7 ll.39–60.

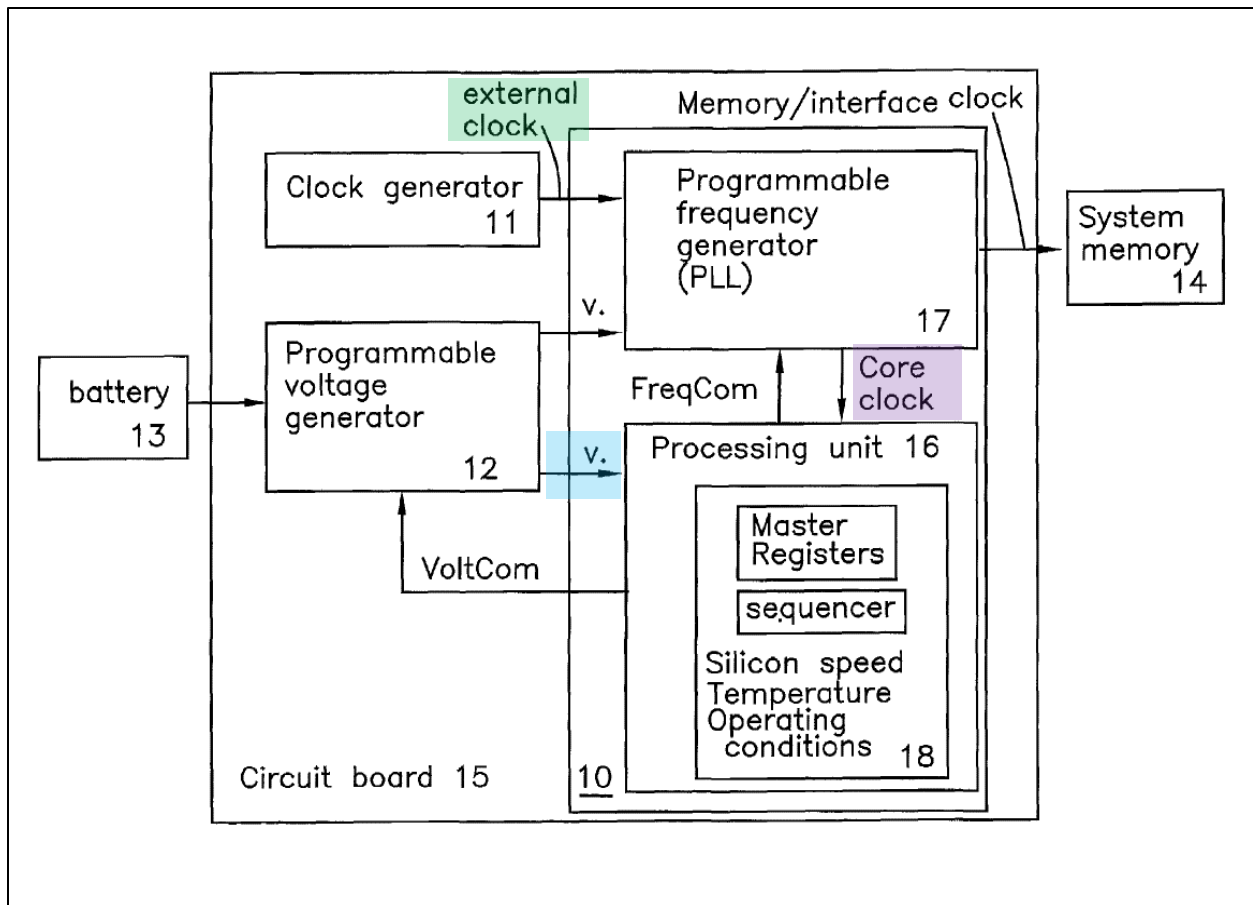

The abstracts of the Asserted Patents are identical and provide as follows:

A method for controlling the power used by a computer including the steps of measuring the operating characteristics of a central processor of the computer, determining when the operating characteristics of the central processor are significantly different than required by the operations being conducted, and changing the operating characteristics of the central processor to a level commensurate with the operations being conducted.

Claims 1 and 17 of the '247 Patent, exemplary method and system claims respectively, provide:

1. A method, comprising:
determining a level of permitted power consumption by a processing device from a set of operating conditions of the processing device, with the determining the level of permitted power consumption not based upon instructions to be executed by the processing device;
determining a highest allowable frequency of operation of the processing device that would result in power consumption not exceeding the level of permitted power consumption;
determining a lowest allowable level of voltage to apply to the processing device that would allow execution of the instructions by the processing device at the highest allowable frequency; and
changing power consumption of the processing device during execution of the instructions by reducing a magnitude of a difference between an operating frequency of the processing device and the highest allowable frequency of operation of the processing device and reducing a magnitude of a difference between a voltage applied to the processing device and the lowest allowable level of voltage.

17. An apparatus, comprising:
a frequency generator configured to generate a first clock signal at a first frequency; and
a processing device configured to receive the first clock signal and a first voltage provided by a voltage source, the processing device operable to monitor operating parameters of the processing device, the processing device operable to determine a second frequency of the first clock signal and a second voltage for operation of the processing device at lower power than operation at the first frequency and the first voltage, with the processing device operable to determine the second frequency and the second voltage not based on instructions to be executed by the processing device, the processing device operable to control the frequency generator to change from generating the first clock signal at the first frequency to generating the first clock signal at a second frequency, and the processing device operable to control the voltage source to change from providing the first voltage to

providing the second voltage during execution of the instructions by the processing device.

II. LEGAL PRINCIPLES

A. Claim Construction

“It is a ‘bedrock principle’ of patent law that ‘the claims of a patent define the invention to which the patentee is entitled the right to exclude.’” *Phillips v. AWH Corp.*, 415 F.3d 1303, 1312 (Fed. Cir. 2005) (en banc) (quoting *Innova/Pure Water Inc. v. Safari Water Filtration Sys., Inc.*, 381 F.3d 1111, 1115 (Fed. Cir. 2004)). To determine the meaning of the claims, courts start by considering the intrinsic evidence. *Id.* at 1313; *C.R. Bard, Inc. v. U.S. Surgical Corp.*, 388 F.3d 858, 861 (Fed. Cir. 2004); *Bell Atl. Network Servs., Inc. v. Covad Commc’ns Group, Inc.*, 262 F.3d 1258, 1267 (Fed. Cir. 2001). The intrinsic evidence includes the claims themselves, the specification, and the prosecution history. *Phillips*, 415 F.3d at 1314; *C.R. Bard, Inc.*, 388 F.3d at 861. The general rule—subject to certain specific exceptions discussed *infra*—is that each claim term is construed according to its ordinary and accustomed meaning as understood by one of ordinary skill in the art at the time of the invention in the context of the patent. *Phillips*, 415 F.3d at 1312–13; *Alloc, Inc. v. Int’l Trade Comm’n*, 342 F.3d 1361, 1368 (Fed. Cir. 2003); *Azure Networks, LLC v. CSR PLC*, 771 F.3d 1336, 1347 (Fed. Cir. 2014) (“There is a heavy presumption that claim terms carry their accustomed meaning in the relevant community at the relevant time.”) (vacated on other grounds).

“The claim construction inquiry ... begins and ends in all cases with the actual words of the claim.” *Renishaw PLC v. Marposs Societa’ per Azioni*, 158 F.3d 1243, 1248 (Fed. Cir. 1998). “[I]n all aspects of claim construction, ‘the name of the game is the claim.’” *Apple Inc. v. Motorola, Inc.*, 757 F.3d 1286, 1298 (Fed. Cir. 2014) (quoting *In re Hiniker Co.*, 150 F.3d 1362, 1369 (Fed. Cir. 1998)). First, a term’s context in the asserted claim can be instructive. *Phillips*, 415 F.3d at

1314. Other asserted or unasserted claims can also aid in determining the claim’s meaning, because claim terms are typically used consistently throughout the patent. *Id.* Differences among the claim terms can also assist in understanding a term’s meaning. *Id.* For example, when a dependent claim adds a limitation to an independent claim, it is presumed that the independent claim does not include the limitation. *Id.* at 1314–15.

“[C]laims ‘must be read in view of the specification, of which they are a part.’” *Id.* (quoting *Markman v. Westview Instruments, Inc.*, 52 F.3d 967, 979 (Fed. Cir. 1995) (en banc)). “[T]he specification ‘is always highly relevant to the claim construction analysis. Usually, it is dispositive; it is the single best guide to the meaning of a disputed term.’” *Id.* (quoting *Vitronics Corp. v. Conceptronic, Inc.*, 90 F.3d 1576, 1582 (Fed. Cir. 1996)); *Teleflex, Inc. v. Ficosa N. Am. Corp.*, 299 F.3d 1313, 1325 (Fed. Cir. 2002). But, “[a]lthough the specification may aid the court in interpreting the meaning of disputed claim language, particular embodiments and examples appearing in the specification will not generally be read into the claims.” *Comark Commc’ns, Inc. v. Harris Corp.*, 156 F.3d 1182, 1187 (Fed. Cir. 1998) (quoting *Constant v. Advanced Micro-Devices, Inc.*, 848 F.2d 1560, 1571 (Fed. Cir. 1988)); *see also Phillips*, 415 F.3d at 1323. “[I]t is improper to read limitations from a preferred embodiment described in the specification—even if it is the only embodiment—into the claims absent a clear indication in the intrinsic record that the patentee intended the claims to be so limited.” *Liebel-Flarsheim Co. v. Medrad, Inc.*, 358 F.3d 898, 913 (Fed. Cir. 2004).

The prosecution history is another tool to supply the proper context for claim construction because, like the specification, the prosecution history provides evidence of how the U.S. Patent and Trademark Office (“PTO”) and the inventor understood the patent. *Phillips*, 415 F.3d at 1317. However, “because the prosecution history represents an ongoing negotiation between the PTO

and the applicant, rather than the final product of that negotiation, it often lacks the clarity of the specification and thus is less useful for claim construction purposes.” *Id.* at 1318; *see also Athletic Alternatives, Inc. v. Prince Mfg.*, 73 F.3d 1573, 1580 (Fed. Cir. 1996) (ambiguous prosecution history may be “unhelpful as an interpretive resource”).

Although extrinsic evidence can also be useful, it is “less significant than the intrinsic record in determining the legally operative meaning of claim language.” *Phillips*, 415 F.3d at 1317 (quoting *C.R. Bard, Inc.*, 388 F.3d at 862). Technical dictionaries and treatises may help a court understand the underlying technology and the manner in which one skilled in the art might use claim terms, but technical dictionaries and treatises may provide definitions that are too broad or may not be indicative of how the term is used in the patent. *Id.* at 1318. Similarly, expert testimony may aid a court in understanding the underlying technology and determining the particular meaning of a term in the pertinent field, but an expert’s conclusory, unsupported assertions as to a term’s definition are not helpful to a court. *Id.* Extrinsic evidence is “less reliable than the patent and its prosecution history in determining how to read claim terms.” *Id.* The Supreme Court has explained the role of extrinsic evidence in claim construction:

In some cases, however, the district court will need to look beyond the patent’s intrinsic evidence and to consult extrinsic evidence in order to understand, for example, the background science or the meaning of a term in the relevant art during the relevant time period. *See, e.g., Seymour v. Osborne*, 11 Wall. 516, 546 (1871) (a patent may be “so interspersed with technical terms and terms of art that the testimony of scientific witnesses is indispensable to a correct understanding of its meaning”). In cases where those subsidiary facts are in dispute, courts will need to make subsidiary factual findings about that extrinsic evidence. These are the “evidentiary underpinnings” of claim construction that we discussed in *Markman*, and this subsidiary factfinding must be reviewed for clear error on appeal.

Teva Pharm. USA, Inc. v. Sandoz, Inc., 574 U.S. 318, 331–32 (2015).

B. Departing from the Ordinary Meaning of a Claim Term

There are “only two exceptions to [the] general rule” that claim terms are construed according to their plain and ordinary meaning: “1) when a patentee sets out a definition and acts as his own lexicographer, or 2) when the patentee disavows the full scope of the claim term either in the specification or during prosecution.”² *Golden Bridge Tech., Inc. v. Apple Inc.*, 758 F.3d 1362, 1365 (Fed. Cir. 2014) (quoting *Thorner v. Sony Computer Entm’t Am. LLC*, 669 F.3d 1362, 1365 (Fed. Cir. 2012)); *see also GE Lighting Solutions, LLC v. AgiLight, Inc.*, 750 F.3d 1304, 1309 (Fed. Cir. 2014) (“[T]he specification and prosecution history only compel departure from the plain meaning in two instances: lexicography and disavowal.”). The standards for finding lexicography or disavowal are “exacting.” *GE Lighting Solutions*, 750 F.3d at 1309.

To act as his own lexicographer, the patentee must “clearly set forth a definition of the disputed claim term,” and “clearly express an intent to define the term.” *Id.* (quoting *Thorner*, 669 F.3d at 1365); *see also Renishaw*, 158 F.3d at 1249. The patentee’s lexicography must appear “with reasonable clarity, deliberateness, and precision.” *Renishaw*, 158 F.3d at 1249.

To disavow or disclaim the full scope of a claim term, the patentee’s statements in the specification or prosecution history must amount to a “clear and unmistakable” surrender. *Cordis Corp. v. Boston Sci. Corp.*, 561 F.3d 1319, 1329 (Fed. Cir. 2009); *see also Thorner*, 669 F.3d at 1366 (“The patentee may demonstrate intent to deviate from the ordinary and accustomed meaning of a claim term by including in the specification expressions of manifest exclusion or restriction, representing a clear disavowal of claim scope.”). “Where an applicant’s statements are amenable

² Some cases have characterized other principles of claim construction as “exceptions” to the general rule, such as the statutory requirement that a means-plus-function term is construed to cover the corresponding structure disclosed in the specification. *See, e.g., CCS Fitness, Inc. v. Brunswick Corp.*, 288 F.3d 1359, 1367 (Fed. Cir. 2002).

to multiple reasonable interpretations, they cannot be deemed clear and unmistakable.” *3M Innovative Proprs. Co. v. Tredegar Corp.*, 725 F.3d 1315, 1326 (Fed. Cir. 2013).

C. Definiteness Under 35 U.S.C. § 112, ¶ 2 (pre-AIA) / § 112(b) (AIA)

Patent claims must particularly point out and distinctly claim the subject matter regarded as the invention. 35 U.S.C. § 112, ¶ 2. A claim, when viewed in light of the intrinsic evidence, must “inform those skilled in the art about the scope of the invention with reasonable certainty.” *Nautilus Inc. v. Biosig Instruments, Inc.*, 572 U.S. 898, 910 (2014). If it does not, the claim fails § 112, ¶ 2 and is therefore invalid as indefinite. *Id.* at 901. Whether a claim is indefinite is determined from the perspective of one of ordinary skill in the art as of the time the application for the patent was filed. *Id.* at 911. As it is a challenge to the validity of a patent, the failure of any claim in suit to comply with § 112 must be shown by clear and convincing evidence. *BASF Corp. v. Johnson Matthey Inc.*, 875 F.3d 1360, 1365 (Fed. Cir. 2017). “[I]ndefiniteness is a question of law and in effect part of claim construction.” *ePlus, Inc. v. Lawson Software, Inc.*, 700 F.3d 509, 517 (Fed. Cir. 2012).

When a term of degree is used in a claim, “the court must determine whether the patent provides some standard for measuring that degree.” *Biosig Instruments, Inc. v. Nautilus, Inc.*, 783 F.3d 1374, 1378 (Fed. Cir. 2015) (quotation marks omitted). Likewise, when a subjective term is used in a claim, “the court must determine whether the patent’s specification supplies some standard for measuring the scope of the [term].” *Datamize, LLC v. Plumtree Software, Inc.*, 417 F.3d 1342, 1351 (Fed. Cir. 2005). The standard “must provide objective boundaries for those of skill in the art.” *Interval Licensing LLC v. AOL, Inc.*, 766 F.3d 1364, 1371 (Fed. Cir. 2014).

D. Previous Constructions of Disputed Terms

D-1. Prior court constructions are entitled to reasoned deference.

The “importance of uniformity in the treatment of a given patent” suggests a level of deference to previous court constructions of disputed claim terms. *See Finisar Corp. v. DirecTV Grp., Inc.*, 523 F.3d 1323, 1329 (Fed. Cir. 2008) (quoting *Markman v. Westview Instruments, Inc.*, 517 U.S. 370, 390 (1996)); *Teva Pharm. USA, Inc. v. Sandoz, Inc.*, 574 U.S. 318, 329 (2015) (noting that “prior cases ... sometimes will serve as persuasive authority”). While the “doctrine of *stare decisis* does not compel one district court judge to follow the decision of another ... previous claim constructions in cases involving the same patent are entitled to substantial weight.” *TQP Dev., LLC v. Intuit Inc.*, No. 2:12-CV-180-WCB, 2014 U.S. Dist. LEXIS 84057, at *21–22 (E.D. Tex. June 20, 2014) (Bryson, J.).

D-2. In some instances, a party may be estopped from pursuing a claim construction different from a prior court construction under the equitable doctrine of issue preclusion.

In some instances, previous court construction of a disputed term may trigger issue preclusion and bind a party to a previous construction. *Teva*, 574 U.S. at 329 (“prior cases will sometimes be binding because of issue preclusion”) (citing *Markman*, 517 U.S. at 391). “Issue preclusion generally refers to the effect of a prior judgment in foreclosing successive litigation of an issue of fact or law actually litigated and resolved in a valid court determination essential to the prior judgment, whether or not the issue arises on the same or a different claim [for relief].” *New Hampshire v. Maine*, 532 U.S. 742, 748–49 (2001). “Issue preclusion prohibits a party from seeking another determination of the litigated issue in the subsequent action.” *Soverain Software LLC v. Victoria's Secret Direct Brand Mgmt., LLC*, 778 F.3d 1311, 1315 (Fed. Cir. 2015) (quoting *State Farm Mut. Auto. Ins. Co. v. Logisticare Sols., LLC*, 751 F.3d 684, 689 (5th Cir. 2014)). Issue preclusion applies only if four conditions are met:

First, the issue under consideration in a subsequent action must be identical to the issue litigated in a prior action. Second, the issue must have been fully and vigorously litigated in the prior action. Third, the issue must have been necessary to support the judgment in the prior case. Fourth, there must be no special circumstance that would render preclusion inappropriate or unfair.

State Farm, 751 F.3d at 689. Ultimately, issue preclusion is an “equitable doctrine” and the “discretion vested in trial courts to determine when it should be applied is broad.” *Nations v. Sun Oil Co.*, 705 F.2d 742, 744 (5th Cir. 1983) (citing *Parklane Hosiery Co., Inc. v. Shore*, 439 U.S. 322, 331 (1979)).

III. AGREED CONSTRUCTIONS

The parties have agreed to the following constructions set forth in their Joint 4-3 Claim Construction and Prehearing Statement (Dkt. No. 41).

Term	Agreed Construction
“computer processor”	“CPU”
“processor”	
“central processor”	
“processing unit”	“computing portion of CPU”
“processing device”	
“clock frequency source”	“clock frequency generator on the same chip as the processor”
“clock frequency generator”	
“safe level” <ul style="list-style-type: none"> • ’708 Patent Claims 30, 32, 42, 44, 48, 50 	“maximum operable temperature”
“a counter” <ul style="list-style-type: none"> • ’627 Patent Claims 1, 10, 16 	“hardware or software that counts”
“clock generator” <ul style="list-style-type: none"> • ’627 Patent Claim 10 • ’247 Patent Claims 3, 4, 14, 15, 21, 22 	plain and ordinary meaning

Term	Agreed Construction
<p>“frequency generator”</p> <ul style="list-style-type: none"> • ’627 Patent Claims 1, 2, 4, 10, 11, 12 • ’247 Patent Claims 2, 3, 4, 10, 14, 15, 17, 21, 22 	<p>“frequency generator on the same chip as the processor”</p>
<p>“in response to initiating a change in frequency ... shut down clocks to said processing unit and said second component”</p> <ul style="list-style-type: none"> • ’627 Patent Claim 1 	<p>“in response to initiating a change in frequency ... shut down clocks, including the core clock, to said processing unit and said second component”</p>
<p>“in response to initiating said change in frequency ... shut down clocks to said processing unit and said second component”</p> <ul style="list-style-type: none"> • ’627 Patent Claim 10 	<p>“in response to initiating said change in frequency ... shut down clocks, including the core clock, to said processing unit and said second component”</p>
<p>“reducing a magnitude of a difference”</p> <ul style="list-style-type: none"> • ’247 Patent Claim 1 	<p>“reducing the absolute value of the difference”</p>
<p>“reducing the magnitude of the difference”</p> <ul style="list-style-type: none"> • ’247 Patent Claims 7, 8 	
<p>“executing ... instructions”</p>	<p>“executing ... instructions using the core clock”</p>
<p>“execution of instructions”</p>	<p>“execution of ... instructions using the core clock”</p>
<p>“execution of the instructions”</p>	<p>“execution of the instructions using the core clock”</p>
<p>“executes instructions”</p>	<p>“executes instructions using the core clock”</p>
<p>“executes the instructions”</p>	<p>“executes ... the instructions using the core clock”</p>
<p>“power supply furnishing selectable output voltages”</p> <ul style="list-style-type: none"> • ’061 Patent Claims 8, 11, 56 	<p>“a power supply providing one of a plurality of distinct voltage levels corresponding to an input”</p>
<p>“power supply ... configured to furnish a selectable voltage”</p> <ul style="list-style-type: none"> • ’627 Patent Claims 5, 25 	<p>“a power supply configured to provide one of a plurality of distinct voltage levels specified by an input”</p>

Term	Agreed Construction
<p>“programmable power supply”</p> <ul style="list-style-type: none"> • ’061 Patent Claim 10 • ’627 Patent Claim 25 	<p>“power supply configured to provide one of a plurality of distinct voltage levels specified by an input”</p>
<p>“programmable voltage supply”</p> <ul style="list-style-type: none"> • ’247 Patent Claims 5, 16, 23 	
<p>“idle state(s)”</p> <ul style="list-style-type: none"> • ’061 Patent Claim 28, 30, 31, 33, 45, 46, 50, 51 	<p>“state in which various components of the system are quiescent”</p>
<p>“idle states of said computer processor”</p> <ul style="list-style-type: none"> • ’061 Patent Claim 44, 49 	
<p>“plurality of idle states of said computer processor”</p> <ul style="list-style-type: none"> • ’061 Patent Claim 30 	
<p>“a selectable voltage”</p> <ul style="list-style-type: none"> • ’627 Patent Claims 5, 24 	<p>“one of a plurality of distinct voltage levels specified by an input”</p>
<p>“voltage source includes a programmable voltage supply”</p> <ul style="list-style-type: none"> • ’247 Patent Claims 16, 23 	<p>“voltage source includes a power supply configured to provide one of a plurality of distinct voltage levels specified by an input”</p>
<p>“operating conditions of [a/said] processing unit”</p> <ul style="list-style-type: none"> • ’627 Patent Claims 4, 16, 23 	<p>“operating conditions of the computing portion of the CPU”</p>
<p>“operating conditions of the processing device”</p> <ul style="list-style-type: none"> • ’247 Patent Claim 1 	
<p>“said operating conditions [of said processing unit]”</p> <ul style="list-style-type: none"> • ’627 Patent Claim 16 	
<p>“the operating conditions [of the processing device]”</p> <ul style="list-style-type: none"> • ’247 Patent Claim 9 	

Having reviewed the intrinsic and extrinsic evidence of record, the Court hereby adopts the parties' agreed constructions.

IV. CONSTRUCTION OF DISPUTED TERMS

- A. **“independently of instructions to be executed by the processor,”**
“independently of instructions to be executed by the central processor,”
“determination made independently of instructions to be executed by the processor” and **“determining step made independently of instructions to be executed by the central processor”**

Disputed Term³	Plaintiff's Proposed Construction	Defendant's Proposed Construction
“independently of instructions to be executed by the processor” • '061 Patent Claims 1, 15, 23, 39, 56	plain and ordinary meaning	without consideration of impending processor usage
“independently of instructions to be executed by the central processor” • '061 Patent Claim 10	plain and ordinary meaning	
“determination made independently of instructions to be executed by the processor” • '061 Patent Claims 1, 15, 23, 39, 56	plain and ordinary meaning	determination made without consideration of impending processor usage
“determining step made independently of instructions to be executed by the central processor” • '061 Patent Claim 10	plain and ordinary meaning	

³ For all disputed-term charts in this order, the claims in which the term is found are listed with the term but: (1) only the highest-level claim in each dependency chain is listed, and (2) only asserted claims identified in the parties' Joint Claim Construction Chart Pursuant to P.R. 4-5(d) (Dkt. No. 51) are listed.

Disputed Term ³	Plaintiff's Proposed Construction	Defendant's Proposed Construction
not based upon instructions to be executed by the processing device • '247 Patent Claims 1, 10	plain and ordinary meaning	without consideration of impending processor usage
not based on instructions to be executed by the processing device • '247 Patent Claim 17	plain and ordinary meaning	

Because the parties' arguments and proposed constructions with respect to these terms are related, the Court addresses the terms together.

The Parties' Positions

Plaintiff submits: These terms do not need to be construed. Defendant's proposed construction improperly limits "instructions to be executed" by the processor to "impending processor usage." Dkt. No. 47 at 8–9, 25–26.

In addition to the claims themselves, Plaintiff cites the following intrinsic and extrinsic evidence to support its position: **Intrinsic evidence:** '061 Patent File Wrapper September 3, 2004 Reply to Action Closing Prosecution⁴ at 14 (Plaintiff's Ex. F, Dkt. No. 47-7 at 14). **Extrinsic evidence:** McAlexander Decl.⁵ ¶¶ 33–34 (Plaintiff's Ex. E, Dkt. No. 47-6); Hansquine Decl.⁶ ¶¶ 122–29 (Plaintiff's Ex. G, Dkt. No. 47-8).

Defendant responds: During reexamination of the '061 Patent, the patentee explained that the "determining step made independently of instructions to be executed by the central processor" excludes determining that considers commands to be executed by the processor. The patentee also

⁴ Inter Partes Reexamination No. 95/000,243.

⁵ Declaration of Joseph C. McAlexander III Regarding Proposed Constructions and Definiteness of the Asserted Claims of U.S. Patent Nos. 7,100,061, 7,596,708, 8,566,627, and 8,806,247.

⁶ Declaration of David Hansquine.

explained a task to be performed by a processor “is necessarily composed of a series of instructions to be executed.” Therefore, “the claims must be construed to reflect this clear disavowal of the disclosed alternative of considering impending processor usage in the power consumption determination.” Dkt. No. 48 at 6–7.

In addition to the claims themselves, Defendant cites the following **intrinsic evidence** to support its position: ’061 Patent File Wrapper September 3, 2004 Reply to Action Closing Prosecution at 2, 4, 6, 8, 10, 17, 21 (Plaintiff’s Ex. F, Dkt. No. 47-7 at 7, 9, 11, 13, 15, 22, 26).

Plaintiff replies: The phrase “impending processor usage” is broader than “instructions to be executed” that is expressed in the claims. Dkt. No. 49 at 5.

Analysis

The issue in dispute distills to whether the term “instructions to be executed” necessarily means “impending processor usage.” It does not.

The Court refuses to rewrite “instructions to be executed” as “impending processor usage.” The prosecution history cited by Defendant does not justify such a construction. Rather, the prosecution history simply states that “instructions to be executed” encompasses the ’061 Patent’s disclosed “commands that have been furnished to be executed” and that a “determination . . . made independently of instructions to be executed” necessarily excludes a determination made using the patent’s disclosed “commands that have been furnished to be executed.” ’061 Patent File Wrapper September 3, 2004 Reply to Action Closing Prosecution at 17, Dkt. No. 47-7 at 22. The patentee further represented that a prior-art task-based determination is not within the scope of a determination made independent of instructions to be executed as a “task is necessarily composed of a series of instructions to be executed by the processor.” *Id.* at 21–22, Dkt. No. 47-7 at 26–27.

Simply, the prosecution history does not redefine “instructions to be executed” as “impending processor usage” as Defendant urges.

Accordingly, the Court rejects Defendant’s proposed construction and determines that these terms each have their plain and ordinary meanings without the need for further construction.

B. “operating conditions of the central processor”

Disputed Term	Plaintiff’s Proposed Construction	Defendant’s Proposed Construction
“operating conditions of the central processor” <ul style="list-style-type: none"> • ’061 Patent Claim 56 	plain and ordinary meaning	operating conditions internal to the central processor

The Parties’ Positions

Plaintiff submits: This term does not need to be construed. Defendant’s proposed construction improperly limits “operating conditions of the central processor” to internal operating conditions. Even if the operating conditions disclosed in the ’061 Patent are all “internal,” these are exemplary rather than definitional. Indeed, the Court in *Amazon.com* recognized the exemplary nature of the disclosure and noted that operating conditions includes “commands to be executed from which a particular type of operation to be executed may be determined” (quoting *Amazon.com* at 33). Further, the Court in *Kyocera* held that “operating conditions” may include “instructions to be executed by the processor,” which instruction would improperly be excluded under Defendant’s construction (citing *Kyocera* at 18). Dkt. No. 47 at 10–11.

In addition to the claims themselves, Plaintiff cites the following **extrinsic evidence** to support its position: Hansquine Decl. ¶ 71 (Plaintiff’s Ex. G, Dkt. No. 47-8).

Defendant responds: As set forth in the ’061 Patent, an operating condition “of” a processor refers to an internal condition of the processor. This was further explained by the patentee during an Inter Partes Review of the ’627 Patent, in which the patentee distinguished external conditions

from conditions “of” a processing unit. The issued here was not addressed by the Court in *Kyocera*, which held that a different term, “operating characteristic(s),” encompassed “instructions to be executed by the processor.” Dkt. No. 48 at 8–9.

In addition to the claims themselves, Defendant cites the following intrinsic and extrinsic evidence to support its position: **Intrinsic evidence:** ’061 Patent figs.1–2, col.2 l.64 – col.3 l.5, col.5 ll.21–29; Patent Owner’s Response at 26, *STMicroelectronics, Inc. v. Semcon IP Inc.*, IPR2017-01431 (’627 Patent) (Feb. 26, 2018 P.T.A.B.) (Defendant’s Ex. D, Dkt. No. 48-5 at 33). **Extrinsic evidence:** Hansquine Decl.⁷ ¶¶ 70–74 (Defendant’s Ex. A, Dkt. No. 48-2).

Plaintiff replies: Nothing in the intrinsic record restricts the operating conditions of a processor to conditions internal to the processor. Dkt. No. 49 at 5–6.

Plaintiff cites further **intrinsic evidence** to support its position: ’061 Patent col.2 l.64 – col.3 l.5; Patent Owner’s Response at 26, *STMicroelectronics, Inc. v. Semcon IP Inc.*, IPR2017-01431 (’627 Patent) (Feb. 26, 2018 P.T.A.B.) (Defendant’s Ex. D, Dkt. No. 48-5 at 33).

Analysis

The issue in dispute is whether the term “operating conditions of the central processor” necessarily means conditions internal to the central processor. It does not.

To begin, it appears the parties agree that Defendant’s proposed construction would exclude “instructions to be executed” from the scope of “operating conditions of the central processor.” This position was squarely addressed—and rejected—by the Court in *Amazon.com* and *Kyocera*. *Amazon.com* at 32–34, 62; *Kyocera* at 18. The Court is not convinced by Defendant’s argument and evidence that the *Amazon.com* and *Kyocera* holdings are incorrect.

⁷ Declaration of David Hansquine. This is the same declaration submitted by Plaintiff as Dkt. No. 47-8.

The intrinsic record does not mandate that “operating conditions of the central processor” are necessarily internal to the processor. As explained in *Amazon.com* and *Kyocera*, the ’061 Patent lists a number of *exemplary* operating conditions (including “commands to be executed”). These lists are explicitly exemplary, not limiting. *Amazon.com* at 32–34; *Kyocera* at 18; *see also*, ’061 Patent col.3 ll.2–15 (introducing conditions with “such as,” “e.g.,” “including,” and “various”). Thus, even if the listed conditions, including the “commands to be executed,” were necessarily “internal” to the processor, the expressly exemplary nature of the listed conditions counsel against reading an “internal” limitation into the claim. Further, it appears the parties agree that “commands to be executed” are not internal to the processor. Finally, the portion of the IPR record Defendant cites does not justify an “internal” limitation. Rather, the argument there appears to state the proposition that measuring the temperature of something other than the processor cannot determine the temperature of the processor. Patent Owner’s Response at 24–27, *STMicroelectronics, Inc. v. Semcon IP Inc.*, IPR2017-01431 (’627 Patent) (Feb. 26, 2018 P.T.A.B.) (“a measurement of an operating characteristic of a processing unit or the temperature of the processing unit cannot be established by taking the temperature of a component that is external to the processing unit CPU”), Dkt. No. 48-5 at 31–34. This does not mean that all operating conditions of the processor are necessarily internal to the processor.

Accordingly, the Court rejects Defendant’s proposed construction and determines that “operating conditions of the central processor” has its plain and ordinary meaning without the need for further construction.

C. “control software dedicated to a central processor”

Disputed Term	Plaintiff’s Proposed Construction	Defendant’s Proposed Construction
“control software dedicated to a central processor” <ul style="list-style-type: none"> • ’061 Patent Claim 10 	plain and ordinary meaning	control software exclusively for controlling the central processor

The Parties’ Positions

Plaintiff submits: This term does not need to be construed. Defendant’s proposed construction improperly limits “control software dedicated to a central processor” to software that is “exclusively for controlling the central processor.” As described in the ’061 Patent, the control software serves a monitoring purpose and thus is not “exclusively for controlling the central processor.” Dkt. No. 47 at 11–12.

In addition to the claims themselves, Plaintiff cites the following intrinsic and extrinsic evidence to support its position: **Intrinsic evidence:** ’061 Patent col.5 ll.21–29. **Extrinsic evidence:** McAlexander Decl. ¶ 38 (Plaintiff’s Ex. E, Dkt. No. 47-6).

Defendant responds: During prosecution of the ’061 Patent, the patentee distinguished the “dedicated” control software from a general purpose operating system—the “dedicated” software exclusively performs a control function whereas a general purpose operating system performs additional functions. This does not exclude monitoring operations that are used for controlling the central processor. Dkt. No. 48 at 5.

In addition to the claims themselves, Defendant cites the following intrinsic and extrinsic evidence to support its position: **Intrinsic evidence:** ’061 Patent File Wrapper February 13, 2004 Amendment and Response at 3, 23 (Defendant’s Ex. B, Dkt. No. 48-3 at 4, 24). **Extrinsic evidence:** Hansquine Decl. ¶ 50 (Defendant’s Ex. A, Dkt. No. 48-2).

Plaintiff replies: The intrinsic evidence does not justify Defendant’s proposed construction. Dkt. No. 49 at 6.

Plaintiff cites further **intrinsic evidence** to support its position: ’061 Patent File Wrapper February 13, 2004 Amendment and Response at 23 (Defendant’s Ex. B, Dkt. No. 48-3 at 24).

Analysis

The issue in dispute is whether the “control software dedicated to a central processor” necessarily has the exclusive, singular, function of controlling the central processor. While the control software is exclusively for the central processor, in that it is dedicated to the processor, it is not necessarily only for controlling the processor.

A plain reading of the claim language suggests that the “control software dedicated to a central processor” is software for control of the central processor and that the software is dedicated to the central processor. This does not mean, however, that the software is dedicated to controlling the central processor. Rather, the software is dedicated to the central processor in that it is not broadly applicable to other processors.

The prosecution history Defendant cites further suggests that the “dedicated” nature of the control software is that is dedicated to the processor, and not necessarily to the control function. For example, during prosecution of the ’061 Patent, the patentee characterized prior-art operating systems as follows:

placing the determination [of operating frequency and voltage] in the operating system ... requires a more generic solution for the wide range of processors on which the operating system may execute. Therefore, it is very difficult for an operating system to provide a solution that is tailored for each processor with which the operating system may be used. This is because characteristics of processors on the market vary dramatically. To accommodate all the processors, the operating system will typically not be tailored for each processor. Rather, the operating system will provide a general solution for all processors. Otherwise, designing and testing the operating system becomes unreasonably difficult.

'061 Patent File Wrapper February 13, 2004 Amendment and Response at 16, Dkt. No. 48-3 at 17.

This explains that an operating system is widely applicable to a variety of processors, rather than being “tailored for each processor.” The patentee then distinguished the “control software” of the pending claim 6 from the prior-art operating system by amending the claim to recite that the “control software” is “dedicated to a central processor.” *Id.* at 3, Dkt. No. 48-3 at 4. The patentee explained as follows:

Claim 6 has been amended to clarify that the control software is dedicated to the central processor. Claim 6 recites that control software that is dedicated to a central processor is used to measure operating characteristics of a central processor of the computer. Claim 6 further recites that control software is used to determine desirable voltages and frequencies for the operation of the central processor based on measured operating characteristics. Applicants respectfully assert that the combination of Harden and Weiss fails to teach or suggest using control software for either this claimed measuring or the claimed determining.

As Applicants have previously discussed, Harden may teach using an operating system for determining voltages and frequencies at which to operate. However, Applicants do not understand an operating system to be the claimed *control software that is dedicated to a processor*.

Id. at 23 (emphasis added), Dkt. No. 48-3 at 24. In other words, the distinction the patentee made between the claimed “control software dedicated to a central processor” and the prior-art operating system is that control software is dedicated to the processor while that operating system “provide[s] a general solution for all processors.”

Accordingly, the Court rejects Defendant’s proposed construction and determines that “control software dedicated to a central processor” has its plain and ordinary meaning without the need for further construction.

D. “operating characteristic”

Disputed Term	Plaintiff’s Proposed Construction	Defendant’s Proposed Construction
“operating characteristic” <ul style="list-style-type: none"> • ’708 Patent Claims 2, 52, 56 	plain and ordinary meaning	parameter(s) that control operation of the processor
“operating characteristics” <ul style="list-style-type: none"> • ’061 Patent Claim 10 • ’708 Patent Claims 3, 8, 9, 33, 53, 55 		

Because the parties’ arguments and proposed constructions with respect to these terms are related, the Court addresses the terms together.

The Parties’ Positions

Plaintiff submits: These terms do not need to be construed. Defendant’s proposed construction improperly limits the terms to parameters that control operation of the processor. The Asserted Patents disclose operating characteristics that do not control operation of the processor, such as the thermal condition operating characteristic in Claim 56 of the ’708 Patent. Further, as held in *Amazon.com* and *Kyocera*, “operating characteristics” are akin to “operating conditions” and thus include instructions to be executed, which would be excluded under Defendant’s proposed construction. Dkt. No. 47 at 12–14.

In addition to the claims themselves, Plaintiff cites the following intrinsic and extrinsic evidence to support its position: **Intrinsic evidence:** ’061 Patent col.2 ll.16–24. **Extrinsic evidence:** McAlexander Decl. ¶¶ 40–41 (Plaintiff’s Ex. E, Dkt. No. 47-6).

Defendant responds: As set forth in the Asserted Patents, “changing operating characteristics” to control the processor is central to the invention of the patents (quoting ’061 Patent col.2 ll.16–24). Thus, the “operating characteristics” are controlled, not just monitored. Claim 56 of the ’708

Patent does not suggest a different meaning. Rather, Claim 56 “refers to both a ‘thermal condition operating characteristic’ and a ‘thermal condition’” and differs from Claim 59 which “refers to both ‘a thermal condition of **said processor**’ and a ‘thermal condition’” (Defendant’s emphasis). That “thermal condition operating characteristic” and “thermal condition” are both used in the claims “shows that the ‘operating characteristic’ referenced in claim 56 refers to a controlled parameter that indicates the ‘thermal condition’ and does not refer directly to the ‘thermal condition’ itself.” Finally, instructions to be executed by the processor control the operation of the processor, so are not excluded by Defendant’s proposed construction. Dkt. No. 48 at 7–8.

In addition to the claims themselves, Defendant cites the following intrinsic and extrinsic evidence to support its position: **Intrinsic evidence:** ’061 Patent col.2 ll.16–24, col.3 ll.47–54. **Extrinsic evidence:** Hansquine Decl. ¶¶ 65–67 (Defendant’s Ex. A, Dkt. No. 48-2).

Plaintiff replies: The Asserted Patents’ disclosure relied upon by Defendant does not support Defendant’s proposed construction. Rather, the disclosure states that operating characteristics are measured, and does not state that the characteristics are exclusively for control of the processor (citing ’061 Patent col.2 ll.16–24). Further, Claim 56 of the ’708 Patent recites that the “consumption of power” is controlled based on the “thermal condition operating characteristic.” Dkt. No. 49 at 6–7.

Analysis

The issue in dispute appears to be whether the “operating characteristic” recited in the claims necessarily refers to a parameter that controls operation of the processor. It does not.

As set forth in the claims, the “operating characteristics” are used for controlling the operation of the processor, but the Asserted Patents do not define “operating characteristics” as Defendant suggests. In pertinent part, the patents provide:

This and other objects of the present invention are realized by a method for controlling the power used by a computer including the steps of utilizing control software to measure the operating characteristics of a processor of the computer, determining when the operating characteristics of the central processor are significantly different than required by the operations being conducted, and changing the operating characteristics of the central processor to a level commensurate with the operations being conducted.

'061 Patent col.2 ll.16–24. This does not state how the characteristics are changed or that the characteristics are necessarily changed to control the processor. Notably, this passage does not exclude that the characteristics may be changed **by** changing operation of the processor. In fact, the patents explain such a use of operating characteristics:

In a first step, the control software monitors various conditions of the processor which relate to power expenditure by the processor. These conditions may include any of those described above including the present frequency and voltage of operation, the temperature of operation, the amount of time the processor spends in one of what may be a number of idle states in which various components of the system are quiescent. ... ***The detection of such operating characteristics*** therefore may indicate that the frequency and voltage of operation should be reduced.

On the other hand, it may be found that the processor is functioning at a reduced frequency and voltage and that a series commands have been furnished to be executed by the processor which require greater processing power. In such a case, these characteristics suggest that it may be desirable to increase the voltage and frequency of operation in order to handle these commands.

Consequently, the control software detects operating characteristics and determines whether those characteristics indicate that the frequency and voltage of operation should be changed.

Id. at col.5 ll.21–57 (emphasis added). In this passage, an operating characteristic such as “the temperature of operation” and “a series commands [that] have been furnished to be executed by the processor” is not directly changed. Rather, the monitored characteristic suggests that the processor’s operating frequency or voltage should be changed.

Ultimately, the use of the “operating characteristic” in the claims is specified in the claims. For example, Claim 10 of the '061 Patent recites “determine desirable reduced voltages and frequencies for the operation of the central processor based on the measured operating

characteristics.” *See also*, ’708 Patent Claim 2 (“determining whether said first voltage should be changed based at least in part on said operating characteristic”), Claim 3 (“determining whether said monitored operating characteristics indicate that the operating frequency of said processor should be changed”), Claim 8 (“said processor determines whether one or more of said monitored operating characteristics indicate that said voltage should be changed”), Claim 9 (“said processor determines whether said monitored operating characteristics indicate that said frequency of operation of said processor should be changed”), Claim 33 (“said processor monitors one or more operating characteristics of said processor and determines whether said monitored operating characteristics indicate that consumption of power by said processor should be decreased,”), Claim 52 (“determining whether said first frequency should be changed based at least in part on said operating characteristic”), Claim 53 (“determining whether said monitored operating characteristics indicate that the operating frequency of said processor should be changed”), Claim 55 (“said processor monitors one or more operating characteristics of said processor and determines whether said monitored operating characteristics indicate that performance of said processor should be increased”), Claim 56 (“said processor monitors a thermal condition operating characteristic and adjusts the consumption of power based at least in part on said thermal condition”).

Accordingly, the Court rejects Defendant’s proposed construction and determines that “operating characteristic” has its plain and ordinary meaning without the need for further construction.

E. “sleep state”

Disputed Term	Plaintiff’s Proposed Construction	Defendant’s Proposed Construction
“sleep state” <ul style="list-style-type: none"> • ’061 Patent Claims 31, 46, 51 	plain and ordinary meaning	indefinite

The Parties’ Positions

Plaintiff submits: In the context of the intrinsic record, the meaning of “sleep state” is apparent to one of ordinary skill in the art. For example, the Asserted Patents described an exemplary sleep state, a “deep sleep state” (citing ’061 Patent col.5 ll.21–45). Other sleep states are set forth in processor technical datasheets. Dkt. No. 47 at 14–15.

In addition to the claims themselves, Plaintiff cites the following intrinsic and extrinsic evidence to support its position: **Intrinsic evidence:** ’061 Patent col.5 ll.21–45. **Extrinsic evidence:** McAlexander Decl. ¶ 45 (Plaintiff’s Ex. E, Dkt. No. 47-6).

Defendant responds: “The term ‘sleep state’ typically carries the same meaning as ‘deep sleep’” (citing Hansquine Decl. ¶ 96). The Court in *Huawei*, however, determined “that ‘sleep state’ and ‘deep sleep state, are *not* synonymous” (Defendant’s emphasis). Indeed, “Semcon seems to attack this Court’s previous holding by arguing that ‘the deep sleep state is an example or embodiment of the sleep state.’” Further, resort to processor datasheets does not “provide sufficient guidance to determine what if anything in the datasheet corresponds to a ‘sleep state,’ as opposed to a ‘deep sleep state’ or some other state” and would subject the meaning of this term to “unknown decision making of the datasheet drafter.” Thus, the meaning of “sleep state” is not reasonably certain. Dkt. No. 48 at 13–14.

In addition to the claims themselves, Defendant cites the following intrinsic and extrinsic evidence to support its position: **Intrinsic evidence:** ’061 Patent File Wrapper July 7, 2003

Amendment and Response at 8 (Defendant's Ex. C, Dkt. No. 48-4 at 9). **Extrinsic evidence:** Hansquine Decl. ¶ 96 (Defendant's Ex. A, Dkt. No. 48-2).

Plaintiff replies: The "deep sleep state" is a type of "sleep state" Dkt. No. 49 at 7.

Analysis

The issue in dispute is whether the meaning of "sleep state" is reasonably certain. It is.

To begin, nothing in *Huawei* suggests that "deep sleep state" is not a "sleep state." Indeed, the Court's analysis there was based on the common-sense principle the terms should be analyzed in context of surrounding claim language. *Huawei* at 34. Thus, the Court noted that "sleep state" and "deep sleep state" provide different contexts which suggest the terms are not synonymous. *Id.* This common-sense principle is well-established in claim-construction jurisprudence. For example, the Federal Circuit has noted: "To begin with, the context in which a term is used in the asserted claim can be highly instructive. To take a simple example, the claim in this case refers to 'steel baffles,' which strongly implies that the term 'baffles' does not inherently mean objects made of steel." *Phillips v. AWH Corp.*, 415 F.3d 1303, 1314 (Fed. Cir. 2005)). The *Huawei* holding that "Defendants have not established" that "sleep state" and "deep sleep state" are synonyms does not suggest that "deep sleep state" may not be an example of a "sleep state" any more than *Phillips* suggests that a "steel baffle" may not be an example of a "baffle." Rather, the use of "deep sleep state" suggests that not all sleep states are "deep sleep states." Defendant's apparent position on this is not reasonable.

Further, Defendant's expert's opinion on this issue is not credible. Mr. Hansquine states without support that: "a person of ordinary skill in the art [would] conclude 'sleep state' is meant to refer to the 'deep sleep state' defined in the '061 Patent specification at 5:35-37." Hansquine Decl. ¶ 96, Dkt. No. 48-2 at 39-40. To begin, such a conclusory—unsupported—statement is not

helpful to the Court. He does not explain why “sleep state” in the claims would be understood as the “deep sleep state” described in the Asserted Patents. Further, he notes that the Court reached a different conclusion in *Huawei*, but fails to address the analysis in *Huawei*. *Id.* Specifically, *Huawei* provided as follows:

To begin, the Power-Management Patents do not include a definition of “sleep state.” Rather, they include a definition of “deep sleep state.” “The deep sleep state is a state in which power is furnished only to the processor and to DRAM memory. In this state, the processor are all off and it does not respond to any interrupts.” ’061 Patent col.5 ll.35–38 (emphasis added). While this statement explains a “deep sleep state,” it does not satisfy the “exacting standard” for a definition of “sleep state.” *GE Lighting Sols., LLC v. AgiLight, Inc.*, 750 F.3d 1304, 1309 (Fed. Cir. 2014) (“The standards for finding lexicography and disavowal are exacting. To act as its own lexicographer, a patentee must clearly set forth a definition of the disputed claim term, and clearly express an intent to define the term.” (quotation marks omitted)). For example, what part of the definition is attributable to “sleep state” and what part to “deep”? Defendants suggest “deep sleep state” and “sleep state” are synonymous. The Court is not persuaded. *Phillips*, 415 F.3d at 1314 (noting that the use of the term “steel baffles” “strongly implies that the term ‘baffles’ does not inherently mean objects made of steel”). Plaintiff’s expert opines the “sleep state” has an ordinary meaning in the art and that it used [that] way in the patents. Rosing Decl. ¶ 17, Dkt. No. 122-1 at 6. As Defendants have not established the contrary, the Court concludes that “sleep state” has its plain and ordinary meaning.

Huawei at 34 (quotation modification marks omitted). Mr. Hansquine does not address this analysis.

Notably, Mr. Hansquine is entirely silent regarding whether “sleep state” is a term of art and instead premises his entire indefiniteness conclusion on the “fact” that “sleep state” should be synonymous with “deep sleep state” but is not because *Huawei* stated so. Specifically, he concluded that “if ‘sleep state’ is not synonymous with ‘deep sleep state’, then to the extent it can be understood, I believe the term ‘sleep state’ is indefinite in the context of the Asserted Patents.” Hansquine Decl. ¶ 98, Dkt. No. 48-2 at 40. It is not clear what Mr. Hansquine means that “to the extent it can be understood,” “sleep state” is indefinite. If it can be understood to an extent, it seems that its meaning would be reasonably certain. In any event, it is clear that Mr. Hansquine failed to

present analysis that is useful to the Court. Instead, he assumes the very facts that are essential to his indefiniteness conclusion. The law requires much more. Indeed, “any fact critical to a holding on indefiniteness must be proven by the challenger by clear and convincing evidence.” *One-E-Way, Inc. v. ITC*, 859 F.3d 1059, 1062 (Fed. Cir. 2017) (quotation and modification marks omitted). Ultimately, Mr. Hansquine’s opinion lacks the hallmarks of reliable expert testimony. *See Phillips*, 415 F.3d at 1318 (“extrinsic evidence consisting of expert reports and testimony is generated at the time of and for the purpose of litigation and thus can suffer from bias”).

Finally, the evidence of record suggests that “sleep state” is a term of art, with various processors providing examples of sleep states. For example, one processor datasheet provides a section entitled “Stop Grant and Sleep States.” AMD, *AMD Athlon Processor Datasheet, Publ’n # 21016, Rev. G* at iii, 12–13 (Dec. 1999), Dkt. No. 47-6 at 32, 55–56.⁸ The datasheet notes that the AMD Athlon “sleep state” is the processor’s “lowest power state.” *Id.* at 14, Dkt. No. 47-6 at 57. Ultimately, whether a particular accused or prior-art processor state is a “sleep state” is an issue of fact.

Accordingly, Defendant has not proven any claim is indefinite for including “sleep state.”

⁸ The data sheet was submitted as McAlexander Decl. Exhibit A, Dkt. No. 47-6 at 29–135.

F. Order of Steps: '061 Patent Claim 1 and '247 Patent Claim 1

Disputed Term	Plaintiff's Proposed Construction	Defendant's Proposed Construction
<p>1. A method for controlling power consumption of a computer processor on a chip comprising the steps of: determining a reduced maximum allowable power consumption level from operating conditions of the processor, said determination made independently of instructions to be executed by the processor, said computer processor determining a maximum frequency which provides power not greater than the allowable power consumption level, said computer processor determining a minimum voltage which allows operation at the maximum frequency determined, and said computer processor dynamically changing its power consumption by changing its frequency and causing a change in its voltage, respectively, to the maximum frequency and the minimum voltage determined, wherein said dynamically changing the power consumption comprises executing instructions in said computer processor while changing voltage at which said computer processor is operated.</p> <ul style="list-style-type: none"> '061 Patent Claim 1⁹ 	<p>plain and ordinary meaning</p>	<p>The sequence of steps as follows:</p> <ol style="list-style-type: none"> determine a reduced maximum allowable power consumption the computer processor uses the maximum allowable power consumption computed from Step 1 to determine a maximum frequency the computer processor uses the maximum frequency from Step 2 to determine a minimum voltage the computer processor changes its frequency and voltage to the values of maximum frequency and minimum voltage computed respectively in Steps 2 and 3

⁹ The modification marks in the claim listed in the Inter Partes Reexamination Certificate (0088th) are omitted.

Disputed Term	Plaintiff's Proposed Construction	Defendant's Proposed Construction
<p>1. A method, comprising: determining a level of permitted power consumption by a processing device from a set of operating conditions of the processing device, with the determining the level of permitted power consumption not based upon instructions to be executed by the processing device; determining a highest allowable frequency of operation of the processing device that would result in power consumption not exceeding the level of permitted power consumption; determining a lowest allowable level of voltage to apply to the processing device that would allow execution of the instructions by the processing device at the highest allowable frequency; and changing power consumption of the processing device during execution of the instructions by reducing a magnitude of a difference between an operating frequency of the processing device and the highest allowable frequency of operation of the processing device and reducing a magnitude of a difference between a voltage applied to the processing device and the lowest allowable level of voltage.</p> <ul style="list-style-type: none"> • '247 Patent Claim 1 	<p>plain and ordinary meaning</p>	<p>The sequence of steps as follows:</p> <ol style="list-style-type: none"> 1. determine a reduced maximum allowable power consumption 2. the computer processor uses the maximum allowable power consumption computed from Step 1 to determine a maximum frequency 3. the computer processor uses the maximum frequency from Step 2 to determine a minimum voltage 4. the computer processor changes its frequency and voltage to the values of maximum frequency and minimum voltage computed respectively in Steps 2 and 3

Because the parties' arguments and proposed constructions with respect to these terms are related, the Court addresses the terms together.

The Parties' Positions

Plaintiff submits: Neither the claim language nor the technical disclosure of the Asserted Patents require that the steps of Claim 1 of the '061 Patent or Claim 1 of the '247 Patent must be performed in the order recited in the claims. In fact, the patent discloses that the voltage may be changed in a single step or as multiple steps, and in some circumstances only the frequency changes. Further, Defendant's proposed construction incorporates limitations beyond ordering that are not supported in the claims. Specifically, the Asserted Patents allow that power consumption may be decreased or increased whereas Defendant's proposed construction would limit these claims to a "reduced maximum allowable power consumption." Dkt. No. 47 at 15–17.

In addition to the claims themselves, Plaintiff cites the following **intrinsic evidence** to support its position: '061 Patent col.5 ll.27–40, col.6 ll.16–24, col.6 ll.30–32.

Defendant responds: The sequence of the steps is mandated because each step "utilize[s] an element determined in an earlier limitation." Thus, as a matter of logic and grammar, the steps must be performed as set forth in the Defendant's proposed constructions. Dkt. No. 48 at 9–10.

Plaintiff replies: "Nothing prevents steps of the claims from being executed simultaneously or in an order which is different from the order in which they are listed in the claim." For example, the frequency and voltage may be determined simultaneously or in reverse order, as through use of a look-up table (citing '247 Patent col.5 l.57 – col.6 l.3). Dkt. No. 49 at 7–8.

Plaintiff cites further **intrinsic evidence** to support its position: '247 Patent col.5 l.57 – col.6 l.3.

Analysis

The issue in dispute appears to be whether the steps of Claim 1 of the '061 Patent and of Claim 1 of the '247 Patent are necessarily performed in the order recited. Based on the record, the Court declines to impose any order that is not expressed in the plain language of the claims.

Defendant has not established that the steps of the claims must be performed in the particular order it suggests. For example, the Asserted Patents provide:

Consequently, the control software detects operating characteristics and determines whether those characteristics indicate that the frequency and voltage of operation should be changed. From the possible sets of conditions, the control software detects the particular set involved and computes correct values for the core clock frequency, the core clock frequency multiplier, the various DRAM clock frequency dividers, and the bus frequency divider. If any other components of the circuitry receive their own clocks, then multipliers or dividers for these values are computed. It should be noted that the control software may actually compute the various values required for the given characteristics which have been determined or may utilize a lookup table storing precomputed values.

'061 Patent col.5 ll.54–67.¹⁰ The Court agrees with Plaintiff that this passage supports looking up the operating voltage and frequency in a single “lookup table storing precomputed values” rather than sequentially determining first the frequency and then subsequently the voltage. For instance, the patents explain:

The power consumed by a CMOS integrated circuit is given approximately by $P=CV^2f$, where C is the active switching capacitance, V is the supply voltage, and f is the frequency of operation. The maximum allowable frequency is described by $f_{max}=kV$, where k is a constant.

'061 Patent col.1 ll.42–47. Thus, in this scenario, there is a predetermined relationship between the frequency and voltage such that determining the frequency in effect determines the voltage. In other words, the voltage for a given frequency may be determined before the frequency is determined for the power-consumption level. Indeed, the equation $P=CV^2f$ suggests that voltage

¹⁰ This passage appears in the '247 Patent at column 5 line 57 through column 6 line 3.

(V) and frequency (f) must be simultaneously considered when determining the maximum frequency for a particular power consumption.

The Court further rejects Defendant’s proposed constructions as presenting limitations well beyond the ordering of steps. Notably, Defendant’s proposed constructions, which are wholesale rewrites of the claims, appear to eliminate any distinction between Claim 1 of the ’061 Patent and Claim 1 of the ’247 Patent.

Accordingly, the Court rejects Defendant’s proposed construction and holds that there is no specific ordering limitation in either Claim 1 of the ’061 Patent or in Claim 1 of the ’247 Patent apart from the limitations expressed in the claims.

G. “determining an allowable reduced power consumption level” and “determining a level of permitted power consumption”

Disputed Term	Plaintiff’s Proposed Construction	Defendant’s Proposed Construction
“determining an allowable reduced power consumption level” <ul style="list-style-type: none"> • ’061 Patent Claim 39 	plain and ordinary meaning	indefinite
“determining a level of permitted power consumption” <ul style="list-style-type: none"> • ’247 Patent Claim 1 	plain and ordinary meaning	indefinite

Because the parties’ arguments and proposed constructions with respect to these terms are related, the Court addresses the terms together.

The Parties’ Positions

Plaintiff submits: These terms “are sufficiently definite and do not require any further construction by the Court.” In fact, the Court addressed this issue in *Huawei* and held that the meanings of these terms are reasonably certain (citing *Huawei* at 22–23). Further, processor

specifications or the power equation disclosed in the Asserted Patents, $P=CV^2f$, may be used to determine the power consumption. Dkt. No. 47 at 17–19.

In addition to the claims themselves, Plaintiff cites the following intrinsic and extrinsic evidence to support its position: **Intrinsic evidence:** '061 Patent col.1 ll.42–45, col.1 ll.48–50. **Extrinsic evidence:** McAlexander Decl. ¶¶ 50–51 (Plaintiff's Ex. E, Dkt. No. 47-6); Hansquine Decl. ¶¶ 81–82 (Plaintiff's Ex. G, Dkt. No. 47-8).

Defendant responds: The terms “allowable reduced power consumption level” and “level of permitted power consumption” do not appear in the Asserted Patents outside of the claim sets and the patents do not otherwise provide “how to determine whether a power consumption level should be permitted or allowed.” Thus, the claims lack the requisite objective boundaries and are indefinite. In fact, the *Huawei* holding on these terms itself fails to provide objective boundaries, as it suggests that the power-consumption level is permitted or allowed depending on “whether an operating condition, setting, or limit is a predetermined ‘safe’ level” and there is no way to determine whether a particular level is a “safe” level, “as opposed to some other predetermined level.” Dkt. No. 48 at 11.

In addition to the claims themselves, Defendant cites the following intrinsic and extrinsic evidence to support its position: **Intrinsic evidence:** '061 Patent col.2 ll.42–47. **Extrinsic evidence:** Hansquine Decl. ¶ 80 (Defendant's Ex. A, Dkt. No. 48-2).

Plaintiff replies: Defendant “appears to confuse definiteness with written description or enablement.” Dkt. No. 49 at 8–9.

Plaintiff cites further **extrinsic evidence** to support its position: McAlexander Decl. ¶¶ 47–52 (Plaintiff's Ex. E, Dkt. No. 47-6).

Analysis

The issue in dispute is whether the meanings of “allowable reduced power consumption level” and “level of permitted power consumption” are reasonably certain in the context of the claims and description of the invention. They are.

This is substantially the same issue as addressed by the Court in *Huawei*. There, the Court held that the meanings of these terms are reasonably certain. The Court is not convinced that the *Huawei* holding is incorrect. For the reasons set forth in *Huawei*, the Court reiterates that the meanings of these terms are reasonably certain when read in the context of the claims in which they appear and the disclosure of the Asserted Patents. *Huawei* at 21–23; *see also*, *Amazon.com* at 52–54 (addressing issue); *ASUSTeK* at 10–11 (adopting an agreed “plain and ordinary” meaning construction for these terms); *Kyocera* at 28–29 (addressing issue).

Accordingly, the Court holds that Defendant has failed to prove that these terms render any claim indefinite.

H. “a normal frequency and voltage”

Disputed Term	Plaintiff’s Proposed Construction	Defendant’s Proposed Construction
“a normal frequency and voltage” <ul style="list-style-type: none"> • ’061 Patent Claim 67 	plain and ordinary meaning	the most common frequency and voltage

The Parties’ Positions

Plaintiff submits: This term does not need to be construed. Defendant’s proposed construction improperly injects ambiguity by replacing “normal” with “most common.” This would exclude an embodiment from the scope of the claims; specifically, the ’061 Patent discloses changing the processor away from the “normal frequency and voltage,” thus allowing that the “most common” frequency and voltage is not the “normal” frequency and voltage (citing ’061 Patent col.5 ll.40–

45). The “normal” frequency and voltage are specified in the processor datasheets. Dkt. No. 47 at 19–20.

In addition to the claims themselves, Plaintiff cites the following intrinsic and extrinsic evidence to support its position: **Intrinsic evidence:** ’061 Patent col.5 ll.40–45. **Extrinsic evidence:** McAlexander Decl. ¶ 56 (Plaintiff’s Ex. E, Dkt. No. 47-6); Hansquine Decl. ¶ 86 (Plaintiff’s Ex. G, Dkt. No. 47-8).

Defendant responds: The ’061 Patent does not explain what it means for a frequency or voltage to be “normal” and “normal mode” is used in technical dictionaries to denote the “expected or usual” or “usual or most common.” Further, it is not clear “which parameters in [a processor] datasheet should correspond to the ‘normal frequency and voltage’” and some processors do not have a datasheet, so reliance on a datasheet does not provide any guidance. Thus, “to the extent the term ‘a normal frequency and voltage’ can be understood, this term should be construed as ‘the most common frequency and voltage.’” Dkt. No. 48 at 12–13.

In addition to the claims themselves, Defendant cites the following intrinsic and extrinsic evidence to support its position: **Intrinsic evidence:** ’061 Patent col.5 ll.30–45, col.7 ll.40–61. **Extrinsic evidence:** Hansquine Decl. ¶ 86 (Defendant’s Ex. A, Dkt. No. 48-2); *Modern Dictionary of Electronics* at 509 (7th ed. 1999), “normal mode” (Defendant’s Ex. G, Dkt. No. 48-8 at 4); *The Illustrated Dictionary of Electronics* at 473 (7th ed. 1997), “normal mode” (Defendant’s Ex. H, Dkt. No. 48-9 at 4).

Plaintiff replies: Defendant’s proposed construction of “normal” as “most common” does not clarify claim scope and instead improperly limits claim scope. Dkt. No. 49 at 9.

Analysis

The issue in dispute is whether “normal frequency and voltage” necessarily refers to the “most common frequency and voltage.” It does not. It refers to the default frequency and voltage of the computer processor for normal-state operation (as distinct from idle-state and sprint-state operations).

The '061 Patent describes the normal frequency and voltage as the settings that sustain normal processor operation without raising the temperature of the processor beyond a safe level. The term “normal frequency and voltage” appears in Claim 67 of the '061 Patent, which provides (with emphasis added):

67. The method of claim 15, wherein said operating conditions include temperature of operation of the computer processor; and wherein the method comprises
determining a frequency and voltage in excess of *a normal frequency and voltage* for said computer processor if said temperature of operation compares in a predetermined manner to a preselected value; and
changing frequency and voltage of operation of the computer processor from said *normal frequency and voltage* to said determined higher frequency and voltage for a period of time.

This claims a scenario in which the processor frequency and voltage are increased beyond “normal” “for a period of time.” The patent explains such a scenario in the following passage:

It should be noted that at some point during the monitoring operation it may be found that the processor is functioning at a normal frequency and voltage, that the temperature of operation is below some preselected value, and that a series of processor-intensive commands have been furnished to be executed by the processor. In such a case, these characteristics suggest that it may be desirable to increase the voltage and frequency of operation in order to handle these commands for a period less than would raise operating temperatures beyond a safe level. In such a case, the control software may compute higher frequency and voltage values and a temperature (or a time within which temperature will not increase beyond a selected level) in order to cause the hardware to move to this higher frequency state of operation. In such a case, the processor executing the process illustrated effectively ramps up the frequency and voltage so that the processor “sprints” for a short time to accomplish the desired operations. This has the effect of allowing a processor which nominally runs at a lower frequency to attain operational rates

reached by more powerful processors during those times when such rates are advantageous.

'061 Patent col.7 ll.39–60. This suggests that the “normal frequency and voltage” is that frequency and voltage that allows for continuous operation under normal operating conditions without raising the temperature of the processor beyond a safe level. This is distinct from the higher-than-normal frequency and voltage of the “sprint” state which will increase the temperature beyond a safe level after a period of time.

The patent also describes that the frequency and voltage may be decreased from the “normal mode of operation” for a processor in idle state in order to conserve power. For example, the patent provides:

In a first step, the control software monitors various conditions of the processor which relate to power expenditure by the processor. These conditions may include any of those described above including the present frequency and voltage of operation, the temperature of operation, the amount of time the processor spends in one of what may be a number of idle states in which various components of the system are quiescent. For example, if the processor is running in what might be termed its normal mode of operation at a core frequency of 400 MHz and a voltage of 1.3 volts, the control software may be monitoring the amount of time the processor spends in the “halt” state, the amount of time the processor spends in the “deep sleep” state, and the temperature of the processor. The deep sleep state is a state in which power is furnished only to the processor and to DRAM memory. In this state, the processor are all off and it does not respond to any interrupts. The halt state is a state in which the core clock has been stopped but the processor responds to most interrupts. If the processor is spending more than a preselected increment of its operation in these states while operating at normal frequency and voltage, then power is being wasted. The detection of such operating characteristics therefore may indicate that the frequency and voltage of operation should be reduced.

'061 Patent col.5 ll.21–45. This suggests that the “normal” frequency and voltage is not necessarily the most common. For example, a processor that is most often in an idle state may be most commonly in a state of below-normal frequency and voltage. The patent’s use of “normal” with reference to processor operating parameters suggests that “normal” is a state distinct from “idle” and “sprint”; “normal” is the default operating state.

The Court rejects Defendant's proposed construction. The term "most common" injects ambiguity into the claims in that it is not clear whether it is for a specific processor (such as the one in counsel's laptop), for a type of processor (such as the AMD Athlon), or for processors in general. The Court recognizes the technical-dictionary definitions submitted by Defendant provide definitions of a "normal mode" as "[t]he expected or usual operating conditions" and "[p]ertaining to a device or system operated in its usual or most common manner." *Modern Dictionary of Electronics* at 509 (7th ed. 1999), Dkt. No. 48-8 at 4; *The Illustrated Dictionary of Electronics* at 473 (7th ed. 1997), Dkt. No. 48-9 at 4. These dictionaries also provide definitions of "norm" as "[a] customary condition or degree" and "[t]he average or ambient condition." *Modern Dictionary of Electronics* at 509 (7th ed. 1999), Dkt. No. 48-8 at 4; *The Illustrated Dictionary of Electronics* at 473 (7th ed. 1997), Dkt. No. 48-9 at 4. These suggest that "normal" could encompass "customary" and "expected," even if not necessarily the "most common."

A processor datasheet of record also suggests that "normal" is not necessarily the most common, but instead refers to the "customary" or "expected" mode of operation. For example, the datasheet provides that the "normal state refers to the default power state and means that all functional units are operating at full processor clock speed." AMD, *AMD Athlon Processor Datasheet, Publ'n # 21016, Rev. G* at 12 (Dec. 1999), Dkt. No. 47-6 at 32.¹¹ Elsewhere in the datasheet, the "normal" state is described as the "the full-on running state of the processor." *Id.* at 14, Dkt. No. 47-6 at 57. This datasheet notes that the "processor is designed to provide functional operation if the voltage and temperature parameters are within" specified limits and specifies that "[f]or normal operating conditions (nominal VCC_CORE is 1.6 V)" and VCC_CORE has a range of 1.5 V to 1.7V as distinct from the "Sleep state" which has a range of 1.2V to 1.7V. *Id.* at 28,

¹¹ The data sheet was submitted as McAlexander Decl. Exhibit A, Dkt. No. 47-6 at 29–135.

Dkt. No. 47-6 at 71. This datasheet also specifies absolute maximum and minimum ratings, beyond which the processor may not function. For example, the maximum VCC_CORE is “nominal + 0.5V.” *Id.* The datasheet also provides “maximum” and “typical” thermal power for the “normal” state at various operating frequencies, and a nominal voltage of 1.6V. *Id.* at 29, Dkt. No. 47-6 at 72. There is no mention of a “most common” frequency or voltage. Rather, “normal” is used in the datasheet as a term art to refer to a specific operating state of the processor, as distinct from other states such as the “halt” and “sleep” states. *Id.* at 12–13, Dkt. No. 47-6 at 55–56. This comports with the use of “normal” in the ’061 Patent. The Court also notes that the AMD Athlon processor datasheet indicates that there is not a singular “normal” frequency and voltage, but rather that these values may be a range of values about a “nominal” value.

Accordingly, the Court construes “a normal frequency and voltage” as follows:

- “a normal frequency and voltage” means “the default frequency and voltage for operation other than in an idle state or sprint state.”

I. The Changing-the-Frequency-While-Execution-of-Instructions-is-Stopped Terms

Disputed Term	Plaintiff’s Proposed Construction	Defendant’s Proposed Construction
“changing an operating frequency ... while execution of instructions ... is stopped” • ’708 Patent Claims 1, 51	plain and ordinary meaning	changing the frequency while the processor receives the stopped clock signal
“changing a frequency of operation ... while execution of instructions is stopped” • ’708 Patent Claim 7	plain and ordinary meaning	

Disputed Term	Plaintiff's Proposed Construction	Defendant's Proposed Construction
“adjusting said programmable frequency generator while instruction execution is stopped to change the frequency” • '708 Patent Claim 20	plain and ordinary meaning	
“while instruction execution is stopped, adjusting said programmable frequency generator to change the frequency” • '708 Patent Claim 23	plain and ordinary meaning	
“changes the ... frequency of operation ... while execution of instructions ... is stopped” • '708 Patent Claims 33, 36, 39, 55, 59	plain and ordinary meaning	
“while instruction execution is disabled ... adjusting said programmable frequency generator to change the frequency” • '708 Patent Claim 26	plain and ordinary meaning	

Because the parties’ arguments and proposed constructions with respect to these terms are related, the Court addresses the terms together.

The Parties’ Positions

Plaintiff submits: This term does not need to be construed. Defendant’s proposed construction appears contrary to the holding in *Amazon.com* that “under the plain meaning of the claims, stopping execution of the instructions is distinct from stopping the clock” (quoting *Amazon.com* at 24–25). Further, Defendant’s construction would improperly limit frequency changes to the period “while the processor receives the stopped clock signal.” Dkt. No. 47 at 20–22.

In addition to the claims themselves, Plaintiff cites the following intrinsic and extrinsic evidence to support its position: **Intrinsic evidence:** '708 Patent col.4 l.62 – col.5 l.1, col.6 ll.24–29. **Extrinsic evidence:** McAlexander Decl. ¶ 62 (Plaintiff's Ex. E, Dkt. No. 47-6).

Defendant responds: Its proposed “construction captures a key requirement of the asserted patents and asserted claims that for a frequency change, only the execution of instructions be stopped, but that the core clock need not be stopped.” Plaintiff's proposed construction is incorrect because it allows “that the core clock may continue to run during a frequency change,” which is “contrary to both the letter and spirit of the claims and the description in the specification.” Dkt. No. 48 at 14–17.

In addition to the claims themselves, Defendant cites the following intrinsic and extrinsic evidence to support its position: **Intrinsic evidence:** '708 Patent col.4 l.54 – col.5 l.12, col.6 ll.26–30, col.6 ll.41–52; '708 Patent File Wrapper June 29, 2007 Amendment and Response Accompanying RCE at 12 (Defendant's Ex. F, Dkt. No. 48-7 at 13); '627 Patent File Wrapper November 7, 2012 Response at 11 (Defendant's Ex. E, Dkt. No. 48-6 at 12). **Extrinsic evidence:** Hansquine Decl. ¶¶ 99–102 (Defendant's Ex. A, Dkt. No. 48-2).

Plaintiff replies: The '708 Patent does not describe a “stopped clock signal,” so the meaning of Defendant's proposed construction is not clear. Further, while the patent describes stopping the clock for a change of frequency, it does not mandate the that clock must be stopped. Similarly, such a limitation is not mandated by the prosecution history. Dkt. No. 49 at 10–11.

Plaintiff cites further **intrinsic evidence** to support its position: '708 Patent col.5 l.13 – col.7 l.18.

Analysis

The issue appears to be whether the processor necessarily receives a “stopped clock” signal in order to stop executing instructions. It does not.

Defendant’s argument appears to suggest that the clock must be stopped for a frequency change, while at the same time maintaining that its construction does not require such. For example, Defendant states: “For a frequency change, the processor does stop the core clock and does not execute instructions.” Dkt. No. 48 at 11; *see also, id.* at 15 (“It is clear then, that [the patent] applicant intended that the core clock is stopped when the frequency is changed.”). Defendant also criticizes a claim-differentiation argument that stopping the clock should not be read into the execution-of-instructions-is-stopped limitations that do not express stopping the clock, noting that ’708 Patent describes taking steps “*to stop the clocks being furnished to these components.*” *Id.* at 16–17 (Defendant’s emphasis). Defendant further criticizes Plaintiff’s position “that the core clock may continue to run during a frequency change” as “contrary to both the letter and spirit of the claims and the description in the specification.” *Id.* at 17. These all suggest that Defendant intends its construction to require stopping the clock. In a contrary statement, however, Defendant states that under its construction “only the execution of instructions [need] be stopped, but [] the core clock need not be stopped.” *Id.* at 14–15. Defendant explains this apparent contradiction as “nuance” meant “to help clarify, for the finder of fact, the process claimed in the ’708 patent.” *Id.* at 16. The nuance is lost on the Court. It certainly does not serve to clarify but rather raises a rather large ambiguity regarding the meaning of “the processor receives the stopped clock signal” if it does not mean that the clock is stopped.

The Court understands Defendant’s position to be substantially the same as that addressed and rejected in *Amazon.com*. There, the Court rejected the position that stopping execution of

instructions to change processor frequency necessarily means that the clock is stopped.

Amazon.com at 22–26. The Court noted:

That executing instructions during a voltage change requires an operational processor clock does not mean that not executing instructions requires stopping the clock. While the embodiments described in the patents do in fact stop the clock for the frequency change, this is not enough to read a stopping-the-clock limitation into all claims directed to changing the frequency—especially considering that some claims express stopping the clock and others do not.

Id. at 24–25. Notably, the Court considered the same intrinsic record in *Amazon.com* as is presented here in support of Defendant’s position. *See id.* at 23. The Court is not convinced that the *Amazon.com* holding is incorrect. For the reasons set forth in *Amazon.com*, the Court reiterates that these terms do not necessarily require that the clock is stopped—or that the processor receives a signal that stops the clocks.

Accordingly, the Court rejects Defendant’s proposed construction and determines that these terms have their plain and ordinary meanings without the need for further construction.

J. “said change in operating conditions”

Disputed Term	Plaintiff’s Proposed Construction	Defendant’s Proposed Construction
“said change in operating conditions” • ’627 Patent Claims 12, 18, 19	not indefinite	indefinite

The Parties’ Positions

Plaintiff submits: In the context of the claims, the meaning of “said change in operating conditions” is apparent to one of ordinary skill in the art; namely, “the claim term ‘said change in operating conditions’ characterizes the claimed operating conditions” set forth in the dependency chain. Dkt. No. 47 at 22–23.

Defendant responds: Claims 12, 18, and 19 of the '627 Patent each fail to provide an antecedent reference for “said change in operating conditions” and the meanings of the claims are thus not reasonably certain. This failure is not one the Court may correct because the patentee submitted a Certificate of Correction to correct obvious clerical errors in the patent but did not address the failure to provide an antecedent reference for this term. Dkt. No. 48 at 21–23.

In addition to the claims themselves, Defendant cites the following **intrinsic evidence** to support its position: '627 Patent Certificate of Correction.

Plaintiff replies: The claims recite a variety of operating conditions and various changes to these conditions. These changes are the antecedent reference to “said change in operating conditions.” Dkt. No. 49 at 11–12.

Plaintiff cites further **intrinsic evidence** to support its position: '627 Patent col.5 ll.23–30.

Analysis

The issue in dispute is whether the meaning of “said change in operating conditions” is reasonably certain in the context of the claims and description of the invention. It is not.

The meaning of “said change in operating conditions” is not reasonably certain in Claim 12 of the '627 Patent. This claim, along with the claims from which it depends, recites as follows (with emphasis added):

10. A computer system comprising:
a processing unit operable at different voltages;
a second component;
a clock generator configured to *generate a first clock signal at a frequency*,
said processing unit configured to register a value corresponding to an amount of time allowed for phase-locked-loop (PLL) circuitry to lock in response to ***a change in frequency*** of said first clock signal; and
a frequency generator coupled to said clock generator and comprising said PLL circuitry, said frequency generator ***configured to*** adjust said frequency of said first clock signal to ***concurrently furnish clock signals at different frequencies to said processing unit and said second component***, wherein said different frequencies are individually adjustable; wherein, in response to

initiating *said change in frequency*, said processing unit is configured to start a counter and to shut down clocks to said processing unit and said second component; and wherein further, in response to said counter reaching said value, said processing unit is configured to turn on said clocks.

11. The computer system of claim **10**, wherein said frequency generator is configured to *adjust said first clock signal* by a first value to furnish a second clock signal at a *second frequency* to said processing unit, wherein said frequency generator is also configured to *adjust said first clock signal* by a second value to furnish a third clock signal at a *third frequency* to said second component, wherein said second frequency is different from said third frequency.

12. The computer system of claim **11**, wherein said frequency generator is further configured to *change said first value to a third value and to change said second value to a fourth value* responsive to *said change in operating conditions*, wherein the ratio of said first value to said third value is different from the ratio of said second value to said fourth value.

The Court understands that “operating condition” is a broad term that encompasses operating frequency and voltage of components, among other things. ’627 Patent col.5 ll.23–30.¹² Thus, the “change in operating conditions” may refer to a change in a variety of conditions of the computer system. The claims, however, present multiple possible conditions and multiple possible changes in conditions. In Claim 10, the PLL circuitry is defined in part relative to a generic “change in frequency” and its ability to provide multiple clock signals at distinct frequencies based on a “first clock signal” frequency. In Claim 11, the first clock signal is adjusted by a first value and by a second value to provide a second frequency to the processor and a third frequency to another component. In Claim 12, the first value and second value are changed “responsive to said change in operating conditions.” It is not clear whether the change in operating conditions refers to the generic change in frequency of the first clock signal in the PLL circuitry, the first-value adjustment to the first clock signal, the second-value adjustment to the second clock signal, the change in frequency to provide the processor frequency (due to the first-value adjustment), or the change in

¹² ’061 Patent col.5 ll.21–29.

frequency to provide the component frequency (due to the second-value adjustment). Perhaps the change in operating conditions refers to all of these or some subset of these? Ultimately, there is not a clear antecedent reference for “said change in operating conditions” and the scope of Claim 12 is not reasonably certain.

The meaning of “said change in operating conditions” is not reasonably certain in Claim 18 or 19 of the ’627 Patent. These claims, along with the claims from which they depend, recite as follows (with emphasis added):

16. A method comprising:

adjusting a first clock signal at a *first frequency* to provide a second clock signal at a *second frequency* to a processing unit of a computer system and a *third clock signal* at a *third frequency* to a second component of said computer system;

monitoring operating conditions of said processing unit;

changing a level of voltage furnished to said processing unit according to said *operating conditions* in response to initiation of a *change in frequency* for said processing unit, starting a counter and stopping said first and second clock signals;

in response to said counter reaching a specified value, restarting said first and second clock signals; and

adjusting said second frequency in response to said *change in frequency*, wherein said second clock signal is individually adjustable without an adjustment to said third clock signal.

17. The method of claim **16**, further comprising:

adjusting said first clock signal by a first value to furnish said second clock signal at said *second frequency* to said processing unit; and

adjusting said first clock signal by a second value to furnish said third clock signal at said *third frequency* to said second component concurrent with furnishing of said second clock signal to said processing unit, wherein said second frequency is different from said third frequency.

18. The method of claim **17**, further comprising changing said first value to a third value responsive to *said change in operating conditions*, wherein said first value is individually adjustable without an adjustment to said second value.

19. The method of claim **18**, further comprising changing said second value to a fourth value responsive to *said change in operating conditions*, wherein the ratio of said first value to said third value is different from the ratio of said second value to said fourth value.

These claims present similar problems to those noted above with respect to Claim 12. Further, Claim 16 recites “monitoring operating conditions of said processing unit” and “changing a level of voltage according to said operating conditions in response to initiation of a change in frequency.” This suggests that the “operating conditions” are distinct from the change in voltage and the change in frequency. It is not clear whether “said change in operating conditions” refers to some change in the monitored operating conditions of the processing unit, to the changes in frequency and voltage for the processing unit, to the adjustments in first clock signal/first frequency to the processing unit, to the adjustments in first clock signal/third frequency to the component, or to some combination or subset thereof. The issue is exacerbated for Claim 19, which depends from Claim 18, in that Claim 18 recites “changing said first value to a third value.” Ultimately, there is not a clear antecedent reference for “said change in operating conditions” and the scopes of Claim 18 and 19 are not reasonably certain.

Accordingly, Defendant has proven that Claims 12, 18, and 19 are invalid as indefinite.

K. “sprint”

Disputed Term	Plaintiff’s Proposed Construction	Defendant’s Proposed Construction
“sprint” • ’627 Patent Claim 15	plain and ordinary meaning	indefinite

The Parties’ Positions

Plaintiff submits: In the context of the intrinsic record, the meaning of “sprint” is apparent to one of ordinary skill in the art. For example, the ’627 Patent describes that a processor’s operating voltage and frequency may be temporarily increased to achieve higher operating rates. Dkt. No. 47 at 23–25.

In addition to the claims themselves, Plaintiff cites the following intrinsic and extrinsic evidence to support its position: **Intrinsic evidence:** '627 Patent col.7 ll.37–50, col.7 ll.53–57. **Extrinsic evidence:** Hansquine Decl. ¶ 113 (Plaintiff's Ex. G, Dkt. No. 47-8).

Defendant responds: The term “sprint” does not have any reasonably certain meaning in the art or in the '627 Patent. While the term “sprints” is used in the description of the invention, this is different than the term “sprint” used in Claim 15. Thus, the description does not provide guidance regarding the meaning of “sprint.” Contemporaneous technical dictionaries similarly provide no guidance regarding what it means for a processing unit to “sprint.” General purpose dictionaries define “sprint” with respect to “running or movement” and therefore similarly provide insufficient guidance regarding the meaning of the term as used in the claim. Dkt. No. 48 at 19–20.

In addition to the claims themselves, Defendant cites the following intrinsic and extrinsic evidence to support its position: **Intrinsic evidence:** '627 Patent col.7 ll.50–53. **Extrinsic evidence:** Hansquine Decl. ¶¶ 113–18 (Defendant's Ex. A, Dkt. No. 48-2).

Plaintiff replies: “A sprint is an increase in operational rates (e.g., frequency, voltage) for a short time.” Dkt. No. 49 at 12–13.

Plaintiff cites further intrinsic and extrinsic evidence to support its position: **Intrinsic evidence:** '627 Patent col.7 ll.50–53. **Extrinsic evidence:** McAlexander Decl. ¶¶ 67–73 (Plaintiff's Ex. E, Dkt. No. 47-6).

Analysis

The issue in dispute is whether the meaning of “sprint” is reasonably certain in the context of the claim and description of the invention. It is. It refers to temporarily operating at higher-than-normal rates.

The term “sprint” appears in Claim 15 of the ’627 Patent, which recites as follows (emphasis added):

15. The computer system of claim **10**, configured to determine an increase in temperature that would result from an increase in said voltage, wherein said processing unit is configured to *sprint* according to said increase in voltage for a period of time that will not cause said temperature to exceed a temperature limit.

Claim 15 is directed to a scenario in which the processor frequency and voltage is increased “for a period of time.” This is similar to Claim 67 of the ’061 Patent which is discussed in the section on “a normal frequency and voltage” above. That discussion also applies to the “sprint” operation recited in Claim 15 of the ’627 Patent. The ’627 Patent explains what it means for a processor to “sprint” in the following passage:

It should be noted that at some point during the monitoring operation it may be found that the processor is functioning at a *normal frequency and voltage*, that the temperature of operation is below some preselected value, and that a series of processor-intensive commands have been furnished to be executed by the processor. In such a case, these characteristics suggest that it may be desirable to increase the voltage and frequency of operation in order to handle these commands for a period less than would raise operating temperatures beyond a safe level. In such a case, the control software may compute higher frequency and voltage values and a temperature (or a time within which temperature will not increase beyond a selected level) in order to cause the hardware to move to this higher frequency state of operation. In such a case, the processor executing the process illustrated effectively ramps up the frequency and voltage so that the processor “*sprints*” for a short time to accomplish the desired operations. *This has the effect of allowing a processor which nominally runs at a lower frequency to attain operational rates reached by more powerful processors* during those times when such rates are advantageous.

’061 Patent col.7 ll.37–57¹³ (emphasis added). This passage contrasts sprinting with running at normal operational rates, a sprint is faster than normal. This comports with the customary, lay, understanding of “sprint” that Defendant’s expert presents. Hansquine Decl. ¶ 115 (declaring that The American Heritage College Dictionary, Third Edition, 1997 defines the verb “sprint” as “to

¹³ The passage is found in the ’061 Patent at column 7, lines 39 through 60.

run or move at top speed especially for a brief period”),¹⁴ Dkt. No. 48-2 at 45–46. Notably, the patent suggests that the processor sprint speed depends on a “safe level” of temperature “or a time within which temperature will not increase beyond a selected level.” Again, this comports with the customary, lay, meaning of “sprint” under which the top speed depends on the duration of the sprint.

The Court is not persuaded by Defendant’s argument. For example, Defendant ignores the above-quoted passage because it refers to “sprints” instead of “sprint.” Dkt. No. 48 at 20. As if the phrase “the processor *sprints*,” found in the description, is meaningless to understanding the phrase “processing unit is configured to *sprint*” in the claim. Defendant’s exegetical approach is not reasonable. Defendant also appears to discount that “sprint” refers a speed relative to some baseline. In the patent, the “sprint” speed is elevated relative to normal operation according to relationship between voltage and frequency. In the customary meaning cited by Defendant’s expert, the “sprint” is the top speed for the duration. Notably, as explained in the above-quoted passage, and as expressed in Claim 15, the speed of the sprint is “according to said increase in voltage for a period of time that will not cause said temperature to exceed a temperature limit.” Given the patent’s teaching that the maximum frequency is related to the voltage, ’627 Patent col.1 ll.51–56 ($f_{max}=kV$), the sprint speed corresponds to the maximum frequency for the increased voltage.

Accordingly, the Court construes “sprint” as follows:

- “sprint” means “temporarily operate at the maximum frequency for a higher-than-normal voltage.”

¹⁴ Defendant did not submit the relevant portion of the dictionary as an exhibit.

L. “nominal operating frequency” and “nominal frequency of operation”

Disputed Term	Plaintiff’s Proposed Construction	Defendant’s Proposed Construction
“nominal operating frequency” <ul style="list-style-type: none"> • ’708 Patent Claims 27, 39, 54, 58 	plain and ordinary meaning	indefinite
“nominal frequency of operation” <ul style="list-style-type: none"> • ’708 Patent Claim 62 	plain and ordinary meaning	indefinite

The Parties’ Positions

Plaintiff submits: In the context of the intrinsic record, the meaning of “nominal frequency of operation” is apparent to one of ordinary skill in the art. For example, the ’708 Patent refers to a processor that “nominally runs at a ... frequency” (quoting ’708 Patent col.7 ll.48–52). Further, the “nominal” frequency and voltage of a processor is specified in processor datasheets. Finally, “nominal frequency” in the art refers to the “ideal” and “labeled” frequency. Dkt. No. 47 at 26–28.

In addition to the claims themselves, Plaintiff cites the following intrinsic and extrinsic evidence to support its position: **Intrinsic evidence:** ’061 Patent col.5 ll.29–35, col.5 ll.40–45; ’708 Patent col.7 ll.48–52. **Extrinsic evidence:** McAlexander Decl. ¶ 75 (Plaintiff’s Ex. E, Dkt. No. 47-6).

Defendant responds: The term “nominal” is a term of degree and “nominal operating frequency” is not used in the Asserted Patents outside of the claim sets; thus, the patents do not provide the necessary objective guidance regarding determining the degree. Further, the term “nominal” may take on a variety of meanings in the art, such “the highest or maximum value, a value mid-way between the minimum and maximum value, or a named or specified value”

(quoting Hansquine Decl. ¶¶ 108–12,¹⁵ Dkt. No. 48-2 at 44–45). The patents do not provide guidance as to which meaning applies to “nominal” in the claims and the meaning thus is subjective, and not reasonably certain. Finally, resort to processor datasheets does not clarify the meaning of “nominal operating frequency” as some datasheets do not provide “nominal” operating parameters and there is no indication in the patents that “nominal” is meant to refer to the datasheets. Dkt. No. 48 at 17–19.

In addition to the claims themselves, Defendant cites the following intrinsic and extrinsic evidence to support its position: **Intrinsic evidence:** ’708 Patent col.7 ll.32–52. **Extrinsic evidence:** Hansquine Decl. ¶¶ 103–112 (Defendant’s Ex. A, Dkt. No. 48-2).

Plaintiff replies: The Asserted Patents use “nominal” (and variants) in the context of comparing a frequency to a normal operating frequency. Thus, the patents provide sufficient guidance as to the meaning. Dkt. No. 49 at 13–14.

Plaintiff cites further **extrinsic evidence** to support its position: McAlexander Decl. ¶¶ 74–76 (Plaintiff’s Ex. E, Dkt. No. 47-6).

Analysis

The issue in dispute is whether the meaning “nominal operating frequency” is reasonably certain. Based on the evidence of record, it is.

These terms are used in the claims to denote a specific processor frequency that is the standard to which other processor frequencies are compared. For example, Claim 27 of the ’708 Patent provides (emphasis added):

27. The method of claim **26**, wherein said *processing unit has a nominal operating frequency* and a corresponding operating voltage, said method further comprising:

¹⁵ Mr. Hansquine cites several dictionaries, but Defendant did not submit copies of the pertinent definitions as exhibits.

said changing comprising setting said second voltage to a value higher than said corresponding operating voltage; and
said adjusting comprising setting said *second frequency* of said processing unit to a value *higher than said nominal operating frequency*.

Claim 62 provides a similar context:

62. The processor of claim **59** wherein said *first frequency is the nominal frequency of operation of the processor*.

What constitutes a “nominal operating frequency” is reasonably certain in the context of the claims and the technical disclosure of the Asserted Patents. The ’708 Patent relates the nominal operating frequency to the operating frequency under normal operating conditions and contrasts it with higher-frequency, “sprint,” states. Specifically, the patent provides:

It should be noted that at some point during the monitoring operation it may be found that the *processor is functioning at a normal frequency and voltage*, that the temperature of operation is below some preselected value, and that a series of processor-intensive commands have been furnished to be executed by the processor. In such a case, these characteristics suggest that it may be desirable to increase the voltage and frequency of operation in order to handle these commands for a period less than would raise operating temperatures beyond a safe level. In such a case, the control software may compute higher frequency and voltage values and a temperature (or a time within which temperature will not increase beyond a selected level) in order to cause the hardware to move to this higher frequency state of operation. In such a case, *the processor executing the process illustrated effectively ramps up the frequency* and voltage so that the processor “sprints” for a short time to accomplish the desired operations. This has the effect of allowing *a processor which nominally runs at a lower frequency* to attain operational rates reached by more powerful processors during those times when such rates are advantageous.

’708 Patent col.7 ll.32–52 (emphasis added). Consistent with the use of the term in the patent, “nominal” is used in the art to denote a manufacturer-specified operating parameter for normal operating conditions. *See, e.g.,* McAlexander Decl. ¶ 75 (quoting the National Institute of Standards and Technology that a “nominal frequency” for an oscillator is an “ideal frequency with zero uncertainty ... [as] labeled on an oscillator’s output”); Hansquine Decl. ¶ 108–12 (citing various dictionary definitions that include definitions of “nominal” as “[n]amed, rated, or

specified” and “nominal value” as “[t]he stated or specified value, as opposed to the actual value”), Dkt. No. 48-2 at 44–45; AMD, *AMD Athlon Processor Datasheet, Publ’n # 21016, Rev. G* at 28 (Dec. 1999) (noting: “For normal operating conditions (nominal VCC_CORE is 1.6 V)” and that VCC_CORE max is “nominal +0.5V”), Dkt. No. 47-6 at 28.¹⁶ While it not clear from the record that every processor has a “nominal operating frequency,” it is reasonably certain that “nominal operating frequency” refers to a manufacturer-stated operating frequency for normal operating conditions.

Accordingly, Defendant has not proven any claim indefinite by reason of including “nominal operating frequency” in the claim and construes the term as follows:

- “nominal operating frequency” means “manufacturer-stated operating frequency for operation other than in an idle state or sprint state” and
- “nominal frequency of operation” means “manufacturer-stated operating frequency for operation other than in an idle state or sprint state.”

V. CONCLUSION

The Court adopts the constructions set forth above, as summarized in the following table. Further, the Court holds that Claims 12, 18, and 19 of the ’627 Patent are invalid as indefinite. The parties are **ORDERED** that they may not refer, directly or indirectly, to each other’s claim-construction positions in the presence of the jury. Likewise, the parties are **ORDERED** to refrain from mentioning any portion of this opinion, other than the actual definitions adopted by the Court, in the presence of the jury. Any reference to claim-construction proceedings is limited to informing the jury of the definitions adopted by the Court.

¹⁶ The data sheet was submitted as McAlexander Decl. Exhibit A, Dkt. No. 47-6 at 29–135.

The parties are hereby **ORDERED** to file a Joint Notice within fourteen (14) days of the issuance of this Memorandum Opinion and Order indicating whether the case should be referred for mediation. If the Parties disagree about whether mediation is appropriate, the Parties should set forth a brief statement of their competing positions in the Joint Notice.

Section	Term	Construction
A	“independently of instructions to be executed by the processor” • ’061 Patent Claims 1, 15, 23, 39, 56	plain and ordinary meaning
	“independently of instructions to be executed by the central processor” • ’061 Patent Claim 10	plain and ordinary meaning
	“determination made independently of instructions to be executed by the processor” • ’061 Patent Claims 1, 15, 23, 39, 56	plain and ordinary meaning
	“determining step made independently of instructions to be executed by the central processor” • ’061 Patent Claim 10	plain and ordinary meaning
	not based upon instructions to be executed by the processing device • ’247 Patent Claims 1, 10	plain and ordinary meaning
	not based on instructions to be executed by the processing device • ’247 Patent Claim 17	plain and ordinary meaning
B	“operating conditions of the central processor” • ’061 Patent Claim 56	plain and ordinary meaning
C	“control software dedicated to a central processor” • ’061 Patent Claim 10	plain and ordinary meaning

Section	Term	Construction
D	“operating characteristic” <ul style="list-style-type: none"> • ’708 Patent Claims 2, 52, 56 	plain and ordinary meaning
	“operating characteristics” <ul style="list-style-type: none"> • ’061 Patent Claim 10 • ’708 Patent Claims 3, 8, 9, 33, 53, 55 	plain and ordinary meaning
E	“sleep state” <ul style="list-style-type: none"> • ’061 Patent Claims 31, 46, 51 	plain and ordinary meaning
F	Order of Steps: ’061 Patent Claim 1 and ’247 Patent Claim 1	plain and ordinary meaning
G	“determining an allowable reduced power consumption level” <ul style="list-style-type: none"> • ’061 Patent Claim 39 	plain and ordinary meaning
	“determining a level of permitted power consumption” <ul style="list-style-type: none"> • ’247 Patent Claim 1 	plain and ordinary meaning
H	“a normal frequency and voltage” <ul style="list-style-type: none"> • ’061 Patent Claim 67 	the default frequency and voltage for operation other than in an idle state or sprint state
I	“changing an operating frequency ... while execution of instructions ... is stopped” <ul style="list-style-type: none"> • ’708 Patent Claims 1, 51 	plain and ordinary meaning
	“changing a frequency of operation ... while execution of instructions is stopped” <ul style="list-style-type: none"> • ’708 Patent Claim 7 	plain and ordinary meaning
	“adjusting said programmable frequency generator while instruction execution is stopped to change the frequency” <ul style="list-style-type: none"> • ’708 Patent Claim 20 	plain and ordinary meaning

Section	Term	Construction
	<p>“while instruction execution is stopped, adjusting said programmable frequency generator to change the frequency”</p> <ul style="list-style-type: none"> • ’708 Patent Claim 23 	plain and ordinary meaning
	<p>“changes the ... frequency of operation ... while execution of instructions ... is stopped”</p> <ul style="list-style-type: none"> • ’708 Patent Claims 33, 36, 39, 55, 59 	plain and ordinary meaning
	<p>“while instruction execution is disabled ... adjusting said programmable frequency generator to change the frequency”</p> <ul style="list-style-type: none"> • ’708 Patent Claim 26 	plain and ordinary meaning
J	<p>“said change in operating conditions”</p> <ul style="list-style-type: none"> • ’627 Patent Claims 12, 18, 19 	indefinite
K	<p>“sprint”</p> <ul style="list-style-type: none"> • ’627 Patent Claim 15 	temporarily operate at the maximum frequency for a higher-than-normal voltage
L	<p>“nominal operating frequency”</p> <ul style="list-style-type: none"> • ’708 Patent Claims 27, 39, 54, 58 	manufacturer-stated operating frequency for operation other than in an idle state or sprint state
	<p>“nominal frequency of operation”</p> <ul style="list-style-type: none"> • ’708 Patent Claim 62 	
AGREED	“computer processor”	“CPU”
	“processor”	
	“central processor”	“computing portion of CPU”
	“processing unit”	
	“processing device”	“clock frequency generator on the same chip as the processor”
	“clock frequency source”	

Section	Term	Construction
	<p>“safe level”</p> <ul style="list-style-type: none"> • ’708 Patent Claims 30, 32, 42, 44, 48, 50 	<p>“maximum operable temperature”</p>
	<p>“a counter”</p> <ul style="list-style-type: none"> • ’627 Patent Claims 1, 10, 16 	<p>“hardware or software that counts”</p>
	<p>“clock generator”</p> <ul style="list-style-type: none"> • ’627 Patent Claim 10 • ’247 Patent Claims 3, 4, 14, 15, 21, 22 	<p>plain and ordinary meaning</p>
	<p>“frequency generator”</p> <ul style="list-style-type: none"> • ’627 Patent Claims 1, 2, 4, 10, 11, 12 • ’247 Patent Claims 2, 3, 4, 10, 14, 15, 17, 21, 22 	<p>“frequency generator on the same chip as the processor”</p>
	<p>“in response to initiating a change in frequency ... shut down clocks to said processing unit and said second component”</p> <ul style="list-style-type: none"> • ’627 Patent Claim 1 	<p>“in response to initiating a change in frequency ... shut down clocks, including the core clock, to said processing unit and said second component”</p>
	<p>“in response to initiating said change in frequency ... shut down clocks to said processing unit and said second component”</p> <ul style="list-style-type: none"> • ’627 Patent Claim 10 	<p>“in response to initiating said change in frequency ... shut down clocks, including the core clock, to said processing unit and said second component”</p>
	<p>“reducing a magnitude of a difference”</p> <ul style="list-style-type: none"> • ’247 Patent Claim 1 	<p>“reducing the absolute value of the difference”</p>
	<p>“reducing the magnitude of the difference”</p> <ul style="list-style-type: none"> • ’247 Patent Claims 7, 8 	
	<ul style="list-style-type: none"> • “executing ... instructions” 	<p>“executing ... instructions using the core clock”</p>
	<ul style="list-style-type: none"> • “execution of instructions” 	<p>“execution of ... instructions using the core clock”</p>

Section	Term	Construction
	<ul style="list-style-type: none"> “execution of the instructions” 	“execution of the instructions using the core clock”
	<ul style="list-style-type: none"> “executes instructions” 	“executes instructions using the core clock”
	<ul style="list-style-type: none"> “executes the instructions” 	“executes ... the instructions using the core clock”
	<p>“power supply furnishing selectable output voltages”</p> <ul style="list-style-type: none"> ’061 Patent Claims 8, 11, 56 	“a power supply providing one of a plurality of distinct voltage levels corresponding to an input”
	<p>“power supply ... configured to furnish a selectable voltage”</p> <ul style="list-style-type: none"> ’627 Patent Claims 5, 25 	“a power supply configured to provide one of a plurality of distinct voltage levels specified by an input”
	<p>“programmable power supply”</p> <ul style="list-style-type: none"> ’061 Patent Claim 10 ’627 Patent Claim 25 	“power supply configured to provide one of a plurality of distinct voltage levels specified by an input”
	<p>“programmable voltage supply”</p> <ul style="list-style-type: none"> ’247 Patent Claims 5, 16, 23 	
	<p>“idle state(s)”</p> <ul style="list-style-type: none"> ’061 Patent Claim 28, 30, 31, 33, 45, 46, 50, 51 	“state in which various components of the system are quiescent”
	<p>“idle states of said computer processor”</p> <ul style="list-style-type: none"> ’061 Patent Claim 44, 49 	
	<p>“plurality of idle states of said computer processor”</p> <ul style="list-style-type: none"> ’061 Patent Claim 30 	
	<p>“a selectable voltage”</p> <ul style="list-style-type: none"> ’627 Patent Claims 5, 24 	“one of a plurality of distinct voltage levels specified by an input”

Section	Term	Construction
	“voltage source includes a programmable voltage supply” • ’247 Patent Claims 16, 23	“voltage source includes a power supply configured to provide one of a plurality of distinct voltage levels specified by an input”
	“operating conditions of [a/said] processing unit” • ’627 Patent Claims 4, 16, 23	“operating conditions of the computing portion of the CPU”
	“operating conditions of the processing device” • ’247 Patent Claim 1	
	“said operating conditions [of said processing unit]” • ’627 Patent Claim 16	
	“the operating conditions [of the processing device]” • ’247 Patent Claim 9	

So ORDERED and SIGNED this 29th day of April, 2020.



 RODNEY GILSTRAP
 UNITED STATES DISTRICT JUDGE