

**IN THE UNITED STATES DISTRICT COURT  
FOR THE EASTERN DISTRICT OF TEXAS  
TYLER DIVISION**

**REEDHYCALOG UK, LTD. and  
REEDHYCALOG, LP**

**Plaintiffs,**

**vs.**

**DIAMOND INNOVATIONS, INC.**

**Defendant.**

§  
§  
§  
§  
§  
§  
§  
§  
§  
§  
§  
§

**CASE NO. 6:08-CV-325  
PATENT CASE**

**MEMORANDUM OPINION AND ORDER**

This Memorandum Opinion construes the terms in the Patents-in-Suit: U.S. Pat. No. 6,585,064 (the “’064 Patent”); U.S. Pat. No. 6,592,985 (the “’985 Patent”); U.S. Pat. No. 6,749,033 (the “’033 Patent”); U.S. Pat. No. 6,589,640 (the “’640 Patent”); U.S. Pat. No. 6,739,214 (the “’214 Patent”); U.S. Pat. No. 6,544,308 (the “’308 Patent”); U.S. Pat. No. 6,797,326 (the “’326 Patent”); U.S. Pat. No. 6,562,462 (the “’462 Patent”); U.S. Pat. No. 6,878,447 (the “’447 Patent”); U.S. Pat. No. 6,861,098 (the “’098 Patent”); U.S. Pat. No. 6,861,137 (the “’137 Patent”); and U.S. Pat. No. 6,601,662 (the “’662 Patent”). The Court further **DENIES** Diamond Innovations, Inc.’s Motion for Summary Judgment of Indefiniteness of U.S. Patent No. 6.592,985 (Docket No. 69) and **DENIES** Diamond Innovations, Inc.’s Motion for Summary Judgment for Indefiniteness of the Thermal Characteristic Patents (Docket No. 71).

**BACKGROUND**

This case involves twelve related patents, each of which claim priority to two provisional patent applications filed in late 2000 and early 2001. Generally, the patents describe a single invention: partially-leached polycrystalline diamond (“PCD”) elements with the thermal

characteristics of fully-leached PCD elements and the impact strength of traditional PCD elements.

The Patents-in-Suit are directed to PCD elements that attach to drill bits and engage the drilled formation. Generally, a sintering process creates the PCD body by combining diamond powder with catalyzing material, usually Cobalt or another metal, at high temperatures and high pressures. The result of the process is a cutting body that contains the diamond and the catalyzing material. This PCD body is attached to a metallic substrate usually through a sintering process that bonds the materials. The composite object is the PCD element.

When fixed on a drill bit, these PCD elements engage and crush the formation. As a result of the friction from this engagement, the PCD elements increase in temperature. The temperature increase causes the PCD elements to experience performance problems. Different thermal expansion rates between the diamond and the catalyzing material cause the PCD element to crack or chip when the temperature of the PCD element exceeds about 400 °C. In addition, the presence of the catalyzing material causes the PCD element's diamond particles to graphitize when the temperature of the PCD element approaches 750 °C. The graphitization process causes the PCD element to crack and decreases its useful lifespan.

A process known as leaching solves the thermal degradation problem by removing the catalyzing material from the PCD body such that only the crystals remain. The resulting PCD element is "thermally stable" and can operate in temperatures up to 1200 °C before it begins to thermally degrade.

This thermally-stable PCD element, however, has weakened impact strength. The weakened impact strength results from gaps in the PCD element that remain after removal of the catalyzing material that resided between the diamond particles. Further, the leaching process removes the PCD

element's metallic substrate, which further reduces the PCD element's impact strength.

The inventors' solution to these prior art problems was to partially leach the catalyzing material from the PCD body. According to the Patents-in-Suit, this partial-leaching achieves thermal characteristics similar to thermally-stable PCD elements while maintaining substantially the same impact strength of unleached PCD elements.<sup>1</sup> The twelve patents claim this invention three different ways: (1) requiring a specific leach depth (the "Depth Patents"<sup>2</sup>); (2) requiring a leach depth such that the PCD body exhibits certain thermal properties (the "Thermal Characteristic Patents"<sup>3</sup>); and (3) requiring a leach depth such that the leached portion of the PCD body has substantially the same impact strength as an unleached portion (the "Impact Strength Patent"<sup>4</sup>).

This case is the third lawsuit that involves the Patents-in-Suit. Prior to this case, ReedHycalog<sup>5</sup> brought suit in May 2006 and alleged infringement of the Impact Strength Patent and the Thermal Characteristic Patents (the "Tyler I" case). The Court construed these patents' claims in September 2007 and March 2008. *ReedHycalog U.K., Ltd. v. Baker Hughes Oilfield Operations, Inc.*, Case No. 6:06-cv-222, Memorandum Opinion & Order (Docket No. 237) (E.D. Tex. Sept. 11, 2007) ("Tyler I Claim Construction Opinion & Order"); *ReedHycalog U.K., Ltd. v. Baker Hughes*

---

<sup>1</sup> From the prosecution of the patent applications, it appears the "impact strength" aspect of the invention was not discovered until the filing of the applications that issued as the Impact Strength Patent and the '308 Patent.

<sup>2</sup> The "Depth Patents" are the '064, '985, '033, '640, '214, '308, '326, and '462 Patents.

<sup>3</sup> The "Thermal Characteristic Patents" are the '447, '098, and '137 Patents.

<sup>4</sup> The "Impact Strength Patent" is the '662 Patent.

<sup>5</sup> The term "ReedHycalog" refers to ReedHycalog U.K., Ltd., ReedHycalog, LP, and Grant Prideco, Inc. collectively.

*Oilfield Operations, Inc.*, Case No. 6:06-cv-222, Memorandum Opinion & Order (Docket No. 460) (E.D. Tex. May 21, 2008) (“Tyler I Supplemental Claim Construction Opinion”). ReedHycalog subsequently brought a second suit in June 2007 and alleged infringement of all twelve Patents-in-Suit (the “Tyler II” case). The Court construed these patents’ claims in April 2009. *ReedHycalog U.K., Ltd. v. United Diamond Drilling Servs., Inc.*, Case No. 6:07-cv-251, Memorandum Opinion (Docket No. 208) (E.D. Tex. April 15, 2009) (“Tyler II Claim Construction Opinion”).<sup>6</sup> In the interim, ReedHycalog brought this case against Diamond Innovations, Inc. (“DI”), and alleges that DI infringes various claims from the Patent-in-Suit.

#### **APPLICABLE LAW**

“It is a ‘bedrock principle’ of patent law that ‘the claims of a patent define the invention to which the patentee is entitled the right to exclude.’” *Phillips v. AWH Corp.*, 415 F.3d 1303, 1312 (Fed. Cir. 2005) (en banc) (quoting *Innova/Pure Water Inc. v. Safari Water Filtration Sys., Inc.*, 381 F.3d 1111, 1115 (Fed. Cir. 2004)). In claim construction, courts examine the patent’s intrinsic evidence to define the patented invention’s scope. *See id.*; *C.R. Bard, Inc. v. U.S. Surgical Corp.*, 388 F.3d 858, 861 (Fed. Cir. 2004); *Bell Atl. Network Servs., Inc. v. Covad Commc’ns Group, Inc.*, 262 F.3d 1258, 1267 (Fed. Cir. 2001). This intrinsic evidence includes the claims themselves, the specification, and the prosecution history. *See Phillips*, 415 F.3d at 1314; *C.R. Bard, Inc.*, 388 F.3d at 861. Courts give claim terms their ordinary and accustomed meaning as understood by one of ordinary skill in the art at the time of the invention in the context of the entire patent. *Phillips*, 415 F.3d at 1312–13; *Alloc, Inc. v. Int’l Trade Comm’n*, 342 F.3d 1361, 1368 (Fed. Cir. 2003).

---

<sup>6</sup> The Court incorporates and adopts its Tyler I Claim Construction Opinion & Order, Tyler I Supplemental Claim Construction Opinion, and Tyler II Claim Construction Opinion.

The claims themselves provide substantial guidance in determining the meaning of particular claim terms. *Phillips*, 415 F.3d at 1314. First, a term’s context in the asserted claim can be very instructive. *Id.* Other asserted or unasserted claims can also aid in determining the claim’s meaning because claim terms are typically used consistently throughout the patent. *Id.* Differences among the claim terms can also assist in understanding a term’s meaning. *Id.* For example, when a dependent claim adds a limitation to an independent claim, it is presumed that the independent claim does not include the limitation. *Id.* at 1314–15.

“[C]laims ‘must be read in view of the specification, of which they are a part.’” *Id.* (quoting *Markman v. Westview Instruments, Inc.*, 52 F.3d 967, 979 (Fed. Cir. 1995) (en banc)). “[T]he specification ‘is always highly relevant to the claim construction analysis. Usually, it is dispositive; it is the single best guide to the meaning of a disputed term.’” *Id.* (quoting *Vitronics Corp. v. Conceptronic, Inc.*, 90 F.3d 1576, 1582 (Fed. Cir. 1996)); *Teleflex, Inc. v. Ficosa N. Am. Corp.*, 299 F.3d 1313, 1325 (Fed. Cir. 2002). This is true because a patentee may define his own terms, give a claim term a different meaning than the term would otherwise possess, or disclaim or disavow the claim scope. *Phillips*, 415 F.3d at 1316. In these situations, the inventor’s lexicography governs. *Id.* Also, the specification may resolve ambiguous claim terms “where the ordinary and accustomed meaning of the words used in the claims lack sufficient clarity to permit the scope of the claim to be ascertained from the words alone.” *Teleflex, Inc.*, 299 F.3d at 1325. But, “[a]lthough the specification may aid the court in interpreting the meaning of disputed claim language, particular embodiments and examples appearing in the specification will not generally be read into the claims.” *Comark Commc’ns, Inc. v. Harris Corp.*, 156 F.3d 1182, 1187 (Fed. Cir. 1998) (quoting *Constant v. Advanced Micro-Devices, Inc.*, 848 F.2d 1560, 1571 (Fed. Cir. 1988)); *see also Phillips*,

415 F.3d at 1323. The prosecution history is another tool to supply the proper context for claim construction because a patent applicant may also define a term in prosecuting the patent. *Home Diagnostics, Inc., v. Lifescan, Inc.*, 381 F.3d 1352, 1356 (Fed. Cir. 2004) (“As in the case of the specification, a patent applicant may define a term in prosecuting a patent.”).

Although extrinsic evidence can be useful, it is “less significant than the intrinsic record in determining the legally operative meaning of claim language.” *Phillips*, 415 F.3d at 1317 (quoting *C.R. Bard, Inc.*, 388 F.3d at 862). Technical dictionaries and treatises may help a court understand the underlying technology and the manner in which one skilled in the art might use claim terms, but technical dictionaries and treatises may provide definitions that are too broad or may not be indicative of how the term is used in the patent. *Id.* at 1318. Similarly, expert testimony may aid a court in understanding the underlying technology and determining the particular meaning of a term in the pertinent field, but an expert’s conclusory, unsupported assertions as to a term’s definition is entirely unhelpful to a court. *Id.* Generally, extrinsic evidence is “less reliable than the patent and its prosecution history in determining how to read claim terms.” *Id.*

## CLAIM TERMS

### Working Surface

The asserted claims contain the term “working surface.” ReedHycalog contends that the term means “any portion of the PCD body which, in operation, may contact the object to be worked.” For the Impact Strength Patent’s claims, ReedHycalog construes “PCD” as “polycrystalline diamond or diamond-like elements.” With respect to the other asserted claims, ReedHycalog does not propose a construction for “PCD.” DI argues that “working surface” means “a top layer (with or without a

chamfer).” The parties dispute whether the “working surface” of a PCD body is limited to the PCD body’s top layer.<sup>7</sup>

The claims and specifications do not limit the working surface to the top layer. The specifications expressly define the working surface as “any portion of the PCD body which, in operation, may contact the object to be worked”:

The working surface 4 is any portion of the PCD body 8 which, in operation, may contact the object to be worked. In this specification, when the working surface 4 is discussed, it is understood that it applies to any portion of the body 8 which may be exposed and/or used as a working surface. Furthermore, any portion of any of the working surface 4 is, in and of itself, a working surface.

’098 Patent, col. 7:27–33.

The specifications also state that the working surface of the PCD cutting element “may be a top working surface 70 and/or a peripheral working surface 72.” *Id.* at col. 12:44–46. These passages refer to Figures 1A and 1B from the Patents-in-Suit, both of which depict the working surface, identified by reference numbers 4, 70, and 72, as encompassing the top and peripheral surfaces of the PCD body:

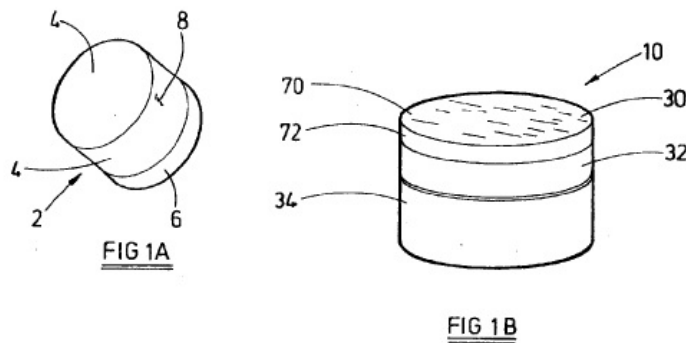

*Figures 1A and 1B from the Patents-in-Suit*

---

<sup>7</sup> DI does not dispute the ReedHycalog’s construction of “PCD” for the different patents.

This disclosure is in accord with the claims, which do not limit the working surface to the top surface. For example, the Impact Strength Patent claims a PCD element where the working surface is adjacent to both a leached volume and an unleached volume, which matches the top and peripheral working surfaces disclosed in Figures 1A and 1B above. '662 Patent, col. 18:23–31 (claiming “a body having a working surface” wherein “a first volume of the body adjacent to working surface contains a catalyzing material” and “a second volume the body adjacent to the working surface is substantially free of the catalyzing material”). Further, the claims in the Thermal Characteristic Patents and Depth Patents do not restrict the working surface to the top layer of the PCD body. *E.g.*, '447 Patent, col. 14:24–33; '214 Patent, col. 14:32–43.

Despite the specifications' definition of “working surface,” DI argues that the Impact Strength Patent's inventors limited the term to a “top layer (with or without the chamfer)” during prosecution before the U.S. Patent & Trademark Office (“PTO”). The prosecution history, however, does not support DI's position.

The doctrine of prosecution history disclaimer “limits the interpretation of claims so as to exclude any interpretation that may have been disclaimed or disavowed during prosecution in order to obtain claim allowance.” *Omeg Eng'g Inc. v. Raytek Corp.*, 334 F.3d 1314, 1323 (Fed. Cir. 2003). For the doctrine to apply, the disclaimer of claim scope must be clear and unmistakable. *Computer Docking Station Corp. v. Dell, Inc.*, 519 F.3d 1366, 1374 (Fed. Cir. 2008). Prosecution disclaimer does not apply where the prosecution history is ambiguous. *See id.* at 1375.

The doctrine of prosecution disclaimer does not apply in this case. During prosecution, the Examiner rejected the Impact Strength Patent's pending claims under 35 U.S.C. § 103(a) as an



obvious variation of U.S. Pat. No. 4,766,040 (“Hillert”) in view of U.S. Pat. No. 6,344,149 (“Oles”). DI’s Responsive Brief, Ex. H, at 2. In response to the rejection, the applicants quoted Hillert’s specification to summarize the reference, which discloses a diamond tool that consists of three superhard layers, one of which Hillert refers to as the “top layer or working surface.” *Id.* at 2–3; Hillert, Fig. 1, col. 4:30–41. The applicants concluded that “the working surface (or top layer) of Hillert et al comprises a homogeneous diamond layer,” and proceeded to contrast the “working surface (or top layer)” disclosed in Hillert with the “working surface” of the applicants’ invention:

[I]n the present invention, the working surface is not homogenous, but rather has at least two distinct regions or volumes; one volume contains a catalyzing material, and the second volume is substantially free of the catalyzing material. Both volumes are present at the working surface. Even though these two volumes have different amounts of catalyzing material, the impact strength of the two volumes is substantially the same. The advantage of this arrangement is that the two volumes will wear differently when used, and therefore they can be arranged so that the working surface selectively wears in favorable geometries.

DI’s Responsive Brief, Ex. H, at 2–3.

Nothing in the prosecution history equates the “working surface (or top layer)” disclosed in Hillert with the “working surface” of the applicants’ invention. This discussion states the opposite—that the “working surface” of the Impact Strength Patent may cover multiple volumes and not only the homogenous top layer disclosed in Hillert. This is consistent with the Impact Strength Patent’s claims, which require the working surface to span leached and unleached regions. ’662 Patent, col. 18:23–31. Thus, the prosecution history of the Impact Strength Patent does not limit the term “working surface” to “a top layer (with or without the chamfer).”

For the above reasons, the Court construes “working surface” as “any portion of the PCD body which, in operation, may contact the object to be worked.” “PCD” means “polycrystalline diamond or diamond-like elements” when used in the Impact Strength Patent’s claims. *See Tyler I Claim Construction Opinion & Order*, 11, 13. With respect to the other asserted claims, “PCD” does not require construction. *See id.* at 13.

### **Thermal Characteristic**

The Thermal Characteristic Patents’ claims require the PCD body to exhibit “a thermal characteristic such that a 950 degrees C. temperature at the working surface results in a temperature of less than 750 degrees C. at the depth.” DI contends that the claimed thermal characteristic is indefinite. ReedHycalog argues that the term is definite and does not require construction.

The Court addressed this dispute in the Tyler I and Tyler II cases, concluded that the claimed thermal characteristic was definite, and found that the term did not require construction. DI argues that ordinarily-skilled artisans knew of many ways to measure the claimed temperatures, that the different methods yield such divergent results that the claims are incapable of measurement and insolubly ambiguous, and that the intrinsic record fails to provide sufficient guidance to save the claims. In support of these arguments, DI proffers an expert declaration from Professor Katherine T. Faber, a host of scientific and technical papers, opinions of counsel, and expert reports on the issue of infringement from the Tyler I and Tyler II cases. After a review of the arguments and relevant evidence, the Court concludes that the claimed thermal characteristic is definite.

A claim is invalid as indefinite under 35 U.S.C. § 112 ¶ 2 if the claim fails to particularly point out and distinctly claim the subject matter the applicants regard as the invention. The primary purpose of the definiteness requirement is to ensure public notice of the scope of the patentee’s legal

protection, such that interested members of the public can determine whether or not they infringe. *Halliburton Energy Servs., Inc. v. M-I, LLC*, 514 F.3d 1244, 1249 (Fed. Cir. 2008). Thus, the definiteness inquiry focuses on how a skilled artisan understands the claims, and a claim is indefinite if the accused infringer shows by clear and convincing evidence that “a skilled artisan could not discern the boundaries of the claim based on the claim language, the specification, and the prosecution history, as well as her knowledge of the relevant art area.” *Id.* at 1249–50.

A claimed parameter is definite “when the relevant values can be ‘calculated or measured.’” *Marley Mouldings Ltd. v. Mikron Indus., Inc.*, 417 F.3d 1356, 1360 (Fed. Cir. 2005) (quoting *W.L. Gore & Assoc., Inc. v. Garlock, Inc.*, 721 F.3d 1540, 1558 (Fed. Cir. 1983)). The bounds of a claim, however, are not sufficiently defined where the number of methods used to measure the claimed parameter, the different results each method yields, and the uncertainty as to which method to use renders the parameter insolubly ambiguous and effectively incapable of measurement. *Honeywell Int’l, Inc. v. Int’l Trade Comm’n*, 341 F.3d 1332, 1339–41 (Fed. Cir. 2003); *Halliburton*, 514 F.3d at 1249; *see also Marley Mouldings*, 417 F.3d at 1360; *Kinetic Concepts, Inc. v. Blue Sky Med. Group, Inc.*, 554 F.3d 1010, 1022 (Fed. Cir. 2009).

#### Temperature at the Working Surface

DI argues that skilled artisans were aware of multiple methods to measure the temperature at the working surface and that these methods produce significantly divergent results. DI submits Professor Faber’s declaration, which lists a number of methods to measure temperature, including the use of thermocouples and pyrometers. DI’s Responsive Claim Construction Brief, Ex. U, at 4–8. Lacking from this declaration is any indication that these methods cannot accurately measure a 950 °C temperature at the working surface of a PCD body or that skilled artisans, knowing the

temperature range to measure, could not select an accurate measurement method. *See In re Gabapentin Patent Litigation*, 395 F. Supp. 2d 164, 173 (D.N.J. 2005).

To show that these methods yield significantly different results and render the claims insolubly ambiguous, DI relies on expert reports from the Tyler I and Tyler II cases on the issue of infringement. These reports, however, do not show that the thermal characteristic is indefinite. The reports only show that opposing experts, retained by interested litigants, utilized different methods to test the accused products for infringement. The reports do not shed light on the universe of tests that were available to a skilled artisan when the Thermal Characteristic Patents were filed, how the results of those tests differ, and which test or set of tests the artisan would choose after reading the Thermal Characteristic Patents.

In any case, the specifications provide sufficient guidance on which method is appropriate to measure a 950 °C temperature at the working surface. The specifications describe using a wear test to calculate a wear index for a partially-leached PCD element. '447 Patent, col. 10:21–col. 11:11. During this test, friction at the working surface inputs heat into the PCD element, and the test allows a skilled artisan to calculate a wear index for the PCD element. *Id.* at col. 10:20–37, col. 11:1–11. The higher the wear index from this test, the more heat the leached portion of the PCD element can withstand before it degrades. *Id.* at col. 10:34–37, col. 10:66–col. 11:26.

Because the wear test generates heat at the working surface via friction, one of ordinary skill in the art would select a measurement method whose accuracy is not affected by the frictional forces present at the working surface. Among the measurement devices listed in Professor Faber's declaration, pyrometers do not require physical contact with the working surface to measure the

surface's temperature. *See* DI's Responsive Claim Construction Brief, Ex. U, at 5–6. Further, Professor Faber states that pyrometry is “best used over 700 °C.” *Id.* at 5.

Pyrometry is “an optical method of measuring temperature based upon the color of light of a radiating body.” *Id.* One device that allows a skilled artisan to employ pyrometry is a disappearing filament pyrometer. *See id.* In the context of the wear test, a skilled artisan would view, through the pyrometer's eyepiece, the color of the light emitted from the working surface. *Id.* While viewing this light, the skilled artisan would determine the working surface's temperature by adjusting the pyrometer until the color of light emitted from a filament within the pyrometer matched the color of light emitted from the working surface. *See id.* When the two colors are the same, the filament “disappears.” *See id.*

This analysis is similar to the “color-of-light” test performed by ReedHycalog's expert, David Hall. Tyler I Claim Construction Opinion & Order, 6. Hall declared that the leached portion of PCD element emits different colored light depending on its temperature during the wear test. *Id.* Hall further declared that those skilled in the art know that emissions of orange light and white-hot light indicate the working surface of the PCD element is 950 °C. *Id.*

While DI challenges the reliability of this test, Professor Faber's identification of pyrometry indicates that Hall's use of the “color-of-light” test does not support a conclusion that the temperature at the working surface is effectively incapable of measurement. Further, Professor Faber's declaration lists additional, and potentially more accurate, pyrometry methods that one of ordinary skill in the art could use to determine if the temperature at the working surface reaches 950 °C during the wear test. Thus, the evidence shows that skilled artisans, at the time the Thermal Characteristic Patents were filed, could measure a 950 °C temperature at the working surface with

sufficient accuracy. Accordingly, this bound of the claimed thermal characteristic is sufficiently defined. *Marley Mouldings*, 417 F.3d at 1360.

### Temperature at the Depth

DI further argues that the temperature at the depth is incapable of being measured or calculated. First, DI argues that skilled artisans were aware of multiple methods to measure the temperature at the depth, that these methods produced significantly different results, and that the specifications or a skilled artisan's knowledge of the relevant art fail to provide sufficient guidance. Second, DI argues that the claimed thermal characteristic is insolubly ambiguous because the specifications fail to specify if the disclosed "wear tests" are operated in "dry" or "wet" conditions.

DI supports its first argument with Professor Faber's declaration, expert reports on the issue of infringement from the Tyler I and Tyler II cases, opinions of counsel, and other technical documents that relate to temperature measurement or calculation in PCD elements. In total, these documents disclose four classes of methods to measure the temperature at the depth: (1) embedded thermocouples; (2) analytical solutions; (3) numerical methods; and (4) inspection of the unleached portion of the PCD body for graphitization. *See e.g.*, Tyler I Claim Construction Opinion & Order, 6; DI's Motion for Summary Judgment, Ex. U, at 6–8. However, DI fails to show that skilled artisans, at the time the Thermal Characteristic Patents were filed, would have been aware of these methods or that these methods produce significantly different results such that the temperature at the depth is effectively incapable of measurement or calculation. *See Gabapentin*, 395 F. Supp. 2d at 173.<sup>8</sup>

---

<sup>8</sup> DI also relies on expert reports on the issue of infringement to show the "a temperature of less than a 750 °C at the depth" is incapable of measurement. For the reasons discussed above, these reports do not show that the claimed thermal characteristic is indefinite.

Moreover, the specifications explain how an ordinarily-skilled artisan could determine if the temperature of the unleached portion of the PCD element did not reach 750 °C during the wear test discussed above. The specifications explain the two modes of thermal degradation of unleached PCD elements, due to different thermal expansion rates (at about 400 °C) and graphitization (at about 750 °C). '447 Patent, col. 2:31–47, col. 9:12–34. Of interest here, the diamond in unleached PCD elements begins to graphitize as the temperature of the unleached PCD element approaches 750 °C. *Id.* at col. 9:24–33. Thus, a person of ordinary skill could, after the wear test completes, inspect the PCD element for graphitization and infer whether the temperatures of the unleached portion reached 750 °C during the wear test. Tyler I Claim Construction Opinion & Order, 6; Tyler II Claim Construction Opinion, 16.

DI argues that this disclosure is insufficient because the specifications do not indicate whether the wear test is operated under “dry” conditions or a “wet” conditions. DI supports this argument with portions of a June 1989 Sandia Report on PCD compact research, which describe a mathematical model to determine temperatures and stresses within an unleached PCD element. DI’s Responsive Claim Construction Brief, Ex. Q, at 44–50. DI relies on Figures 7.3a and 7.3b, reproduced below, which depict the calculated temperatures for a modeled unleached PCD element in “Air Drilling” and “Water Drilling” conditions when the steady-state temperature at the working surface is 700 °C:

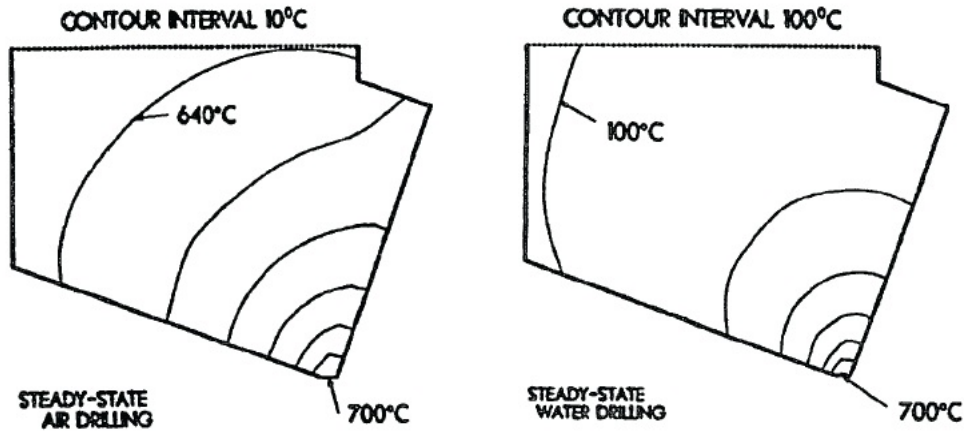

*Id.* at 50.

DI claims that the “Steady-State Air Drilling” of Figure 7.3a refers to the “dry” wear test and the “Steady-State Water Drilling” of Figure 7.3b refers to the “wet” wear test. As the contour intervals show, a model of an unleached PCD element operating in a “wet” environment exhibits a calculated thermal gradient an order of magnitude greater than the calculated thermal gradient that the same modeled PCD element exhibits when operating in a “dry” environment. From these figures, DI infers that a partially-leached PCD element would exhibit the claimed thermal characteristic when the element is tested in “wet” conditions but would not exhibit the thermal characteristic when tested in “dry” conditions.

DI overstates the Sandia Report’s disclosure. The Sandia Report only discloses temperature contour intervals of a modeled unleached PCD element when the working surface of the element reaches 700 °C. The Sandia Report does not indicate how the “wet” and “dry” conditions would affect the thermal characteristic of a partially-leached PCD element with a working surface temperature of 950 °C. Moreover, the Sandia Report lacks any indication that partially-leached PCD elements exhibit the claimed thermal characteristic during “wet” conditions but do not exhibit the



thermal characteristic during “dry” conditions. Without this showing, the failure of the specifications to state whether the wear test should be operated under “wet” or “dry” conditions does not render the claims indefinite. *See Honeywell*, 341 F.3d at 1340-41.

In total, DI has not shown by clear and convincing evidence that the term “a thermal characteristic such that a 950 degrees C. temperature at the working surface results in a temperature of less than 750 degrees C. at the depth” is indefinite. Therefore, the Court concludes the term is definite and **DENIES** DI’s Motion for Summary Judgment for Indefiniteness of the Thermal Characteristic Patents (Docket No. 71). In addition, the claim language is clear and does not require construction. *See Tyler I Claim Construction Opinion & Order*, 8–9, 11; *Tyler II Claim Construction Opinion*, 16.

### **Impact Strength**

The claims of the Impact Strength Patent contain the term “impact strength.” ReedHycalog argues that “impact strength” means “resistance to impact.” DI agrees that the term “impact strength,” as a term of art in materials science and in isolation, means “resistance to impact,” yet contends that the term is indefinite. DI’s arguments focus on the term “impact strength” in the context of the “substantially the same impact strength” and “substantially uniform impact strength” limitations. DI’s Responsive Claim Construction Brief, 28–29. Thus, because the parties do not raise a claim-scope dispute for the term “impact strength” by itself, the Court concludes that “impact strength” means “resistance to impact.”

### **Substantially the Same Impact Strength / Substantially Uniform Impact Strength**

The Impact Strength Patent’s claims contain the terms “wherein the first volume and the second volume have substantially the same impact strength” and “wherein the body has substantially

uniform impact strength.” DI argues that the terms are indefinite. ReedHycalog contends that the term is definite and, except for the term “impact strength,” does not require construction. The Court addressed this dispute in the Tyler I and Tyler II cases, concluded that these terms are definite, and found the terms did not require construction. DI does not raise any new arguments in this case.

The “substantially the same impact strength” limitation requires the leached and unleached portions of the PCD body have “substantially the same impact strength.” ’662 Patent, col. 18:23–31. Similarly, other claims in the Impact Strength Patent require the body of the PCD element to have “substantially uniform impact strength.” *Id.* at col. 20:47–56.

DI argues that the Impact Strength Patent’s claims are indefinite because skilled artisans could not determine how to measure the impact strengths of the claimed volumes or bodies and the ’662 Patent does not disclose any tests or measurement methods. However, DI does not present any evidence that skilled artisans could not measure the impact strength of the claimed volumes or PCD bodies. Absent such a showing, it is irrelevant that the specifications allegedly do not disclose a method to test the impact strength of these materials. *See Marley Mouldings*, 417 F.3d at 1358; *Gabapentin*, 395 F. Supp. 2d at 174.

DI has not shown by clear and convincing evidence that the terms “wherein the first volume and the second volume have substantially the same impact strength” and “wherein the body has substantially uniform impact strength” are indefinite. Thus, the Court concludes the terms are definite. Additionally, the claim language is clear and, apart from the construction of “impact strength,” does not require construction. *See Tyler I Claim Construction Opinion & Order*, 15; *Tyler I Supplemental Claim Construction Opinion*, 5–8; *Tyler II Claim Construction Opinion*, 17–19.

### **The Catalyzing Material Remaining in the Second Volume of the Body Increases with Distance from the Working Surface**

The '985 Patent's claims contain the term "the catalyzing material remaining in the second volume of the body increases with distance from the working surface." *E.g.*, '985 Patent, col. 14:21–31. DI contends that the term is indefinite because the claim does not mention which feature of the catalyzing material (such as amount, composition, or temperature) increases with distance or how that feature increases with distance. ReedHycalog argues that the term is definite and, aside from the constructions of "catalyzing material" and "working surface," that the term does not require construction.

The '985 Patent claims a PCD element that contains a body wherein "a first volume of the body remote from the working surface contains a catalyzing material" and "a second volume of the body adjacent to the working surface is substantially free of the catalyzing material." '985 Patent, col. 14:21–31. This reference to the presence or absence of catalyzing material within a volume indicates that the term "catalyzing material" can refer to an amount of material depending on the surrounding claim language. Indeed, the inventors stated during prosecution that these claimed volumes contain "different amounts of catalyzing material." DI's Responsive Brief, Ex. H, at 3.

The claims then describe that the catalyzing material remaining in the second volume "increases with distance from the working surface and adheres to the surfaces of the diamond crystals." '985 Patent, col. 14:21–31. In the context of this language, the claim can only mean that the amount of catalyzing material remaining in the second volume increases with distance. Any other reading is inconsistent with the claim language and the inventors' statements in the prosecution history.

Further, the claims are not required to specify how the catalyzing material increases over distance. *Oakley, Inc. v. Sunglass Hut Int'l*, 316 F.3d 1331, 1341 (Fed. Cir. 2003) (“[A] patentee need not define his invention with mathematical precision in order to comply with the definiteness requirement.”). Thus, DI has not shown by clear and convincing evidence that the term “the catalyzing material remaining in the second volume of the body increases with distance from the working surface” is indefinite. Accordingly, the Court concludes the term is definite and **DENIES** DI’s Motion for Summary Judgment of Indefiniteness of U.S. Patent No. 6.592,985 (Docket No. 69). In addition, the claim language, except for the terms “working surface” and “catalyzing material,” is clear and does not require construction.

#### **CONCLUSION**

For the foregoing reasons, the Court interprets the claim language in this case in the manner set forth above. For ease of reference, the Court’s claim interpretations are set forth in a table as Appendix A.

**So ORDERED and SIGNED this 30th day of November, 2009.**

A handwritten signature in black ink, appearing to read 'Leonard Davis', written over a horizontal line.

**LEONARD DAVIS  
UNITED STATES DISTRICT JUDGE**

## APPENDIX A

<b>Claim Term</b>	<b>Court's Construction</b>
Working surface	Any portion of the PCD body which, in operation, may contact the object to be worked
Thermal characteristic	[No construction necessary]
Impact strength	Resistance to impact
Substantially the same impact strength / Substantially uniform impact strength	[No construction necessary]
The catalyzing material remaining in the second volume of the body increases with distance from the working surface	[No construction necessary]