

**IN THE UNITED STATES DISTRICT COURT  
FOR THE EASTERN DISTRICT OF TEXAS  
TYLER DIVISION**

**RAYLON LLC,**

**Plaintiff**

**vs.**

**COMPLUS DATA INNOVATIONS, et al.,**

**Defendants**

§  
§  
§  
§  
§  
§  
§  
§  
§  
§

**CASE NO. 6:09-CV-355  
PATENT CASE**

**RAYLON LLC,**

**Plaintiff**

**vs.**

**ADVANCED PUBLIC SAFETY, INC., et  
al.,**

**Defendants**

§  
§  
§  
§  
§  
§  
§  
§  
§  
§

**CASE NO. 6:09-CV-356  
PATENT CASE**

**RAYLON LLC,**

**Plaintiff**

**vs.**

**EZ TAG CORPORATION, et al.,**

**Defendants**

§  
§  
§  
§  
§  
§  
§  
§  
§  
§

**CASE NO. 6:09-CV-357  
PATENT CASE**

**MEMORANDUM OPINION AND ORDER**

Upon consideration of the parties’ written submissions and oral arguments, the Court  
**GRANTS** Casio America, Inc. and Casio Computer, Co., Ltd.’s (collectively “Casio”) Motion for

Summary Judgment of Non-Infringement (Docket No. 8 in 6:09cv355), **GRANTS** Complus Data Innovations’ (“Complus”) Motion for Summary Judgment of Non-Infringement (Docket No. 25 in 6:09cv355), **DENIES AS MOOT** Casio’s Motion for Summary Judgment on Invalidity (Docket No. 128 in 6:09cv355), **CONVERTS** Symbol Technologies, Inc.’s (“Symbol”) Motion for Judgment on the Pleadings (Docket No. 70 in 6:09cv356) to a Motion for Summary Judgment of Non-Infringement and **GRANTS** the motion, **DENIES AS MOOT** EZ Tag Corporation’s (“EZ Tag”) Motion to Dismiss for Lack of Jurisdiction and Venue<sup>1</sup> (Docket No. 70 in 6:09cv357), **DENIES AS MOOT** Raylon LLC’s (“Raylon”) Motion for Jurisdictional Discovery as to Contacts of EZ Tag Corporation in (Docket No. 72 in 6:09cv357), **DENIES AS MOOT** Raylon’s Motion for Summary Judgment of Indefiniteness (Docket No. 92 in 6:09cv357), and **DENIES AS MOOT** Casio’s Motion for Summary Judgment of Invalidity (Docket No. 96 in 6:09cv357).

## **BACKGROUND**

Raylon filed three Complaints on August 10, 2009 accusing Defendants of infringing U.S. Patent No. 6,655,589 (“the ’589 patent”).<sup>2</sup> The ’589 patent, entitled “Identification investigating and ticket issuing system,” was filed on August 31, 2001 and issued on December 2, 2003. In general, the ’589 patent relates to handheld computers that read magnetic tapes on an identification card (e.g. driver’s license), display and transmit information, and print tickets. There are three independent claims: claims 1, 16, and 17. The claims are system claims.

---

<sup>1</sup>Upon the Court’s inquiry of the status of EZ Tag’s motion to transfer during the claim construction hearing, EZ Tag verbally withdrew the motion. Tr. at 33:17-19.

<sup>2</sup>Raylon brings the 6:09cv355 case against Complus, Casio, Fujitsu America, Inc., Fujitsu Japan Ltd. (collectively “Fujitsu”), Psion Teklogix, Inc., and Psion Teklogix Corporation. Raylon brings the 6:09cv356 case against Advanced Public Safety, Inc., Casio, Symbol, Intermec, Research In Motion Corporation, Tripod Data Systems, and Zebra Technologies Corporation (“Zebra”). Raylon brings the 6:09cv357 case against EZ Tag and Casio.

The day after filing its Answer, Casio filed a Motion for Summary Judgment of Non-Infringement. Shortly thereafter, Complus likewise followed suit. Docket Nos. 8 and 25 in 6:09cv355. The premature motions were denied without prejudice because the case was still at a rudimentary stage and the claims had not yet been construed. Docket Nos. 120, 121 in 6:09cv355. Before the *Markman* hearing, Complus and Casio re-urged their motions, representing that the construction of a single term, “display being pivotally mounted on said housing,” would completely resolve liability in all three cases.<sup>3</sup> Docket No. 122 in 6:09cv355. The Court granted leave and allowed summary judgment arguments at the *Markman* hearing.<sup>4</sup> Docket No. 133 in 6:09cv355.

All of the independent claims of the '589 patent require a “display being pivotally mounted on said housing.” *See* '589 patent at 7:30-31 (claim 1), 8:56-57 (claim 16), 9:21-22 (claim 17). The patent describes the display as “[a] display 39 is provided for displaying data entered into the input assembly 22. The display 39 may be pivotally mounted on the housing 12 and may be positioned generally adjacent to the first end 13 of the housing 12.” '589 patent at 5:58-61; *see also id.* at Abstract; 1:38-39; 2:11-12, 3:30-32; 5:58-65. Figures 1 and 2 depict the pivotal display:

---

<sup>3</sup>Defendants also filed motions for summary judgment on invalidity. The Court’s rulings during the claim construction hearing rendered the arguments of invalidity moot.

<sup>4</sup>Although the *Markman* hearing was scheduled in the 6:09cv355 and 6:09cv357 cases, the Court granted Symbol leave to file an *amicus curiae* claim construction brief and be heard at the *Markman* hearing.

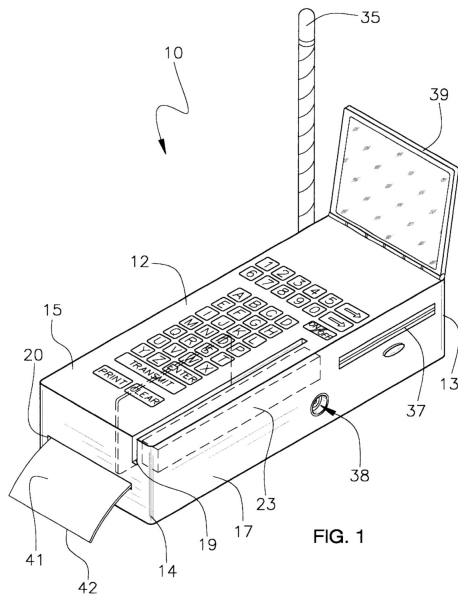

FIG. 1

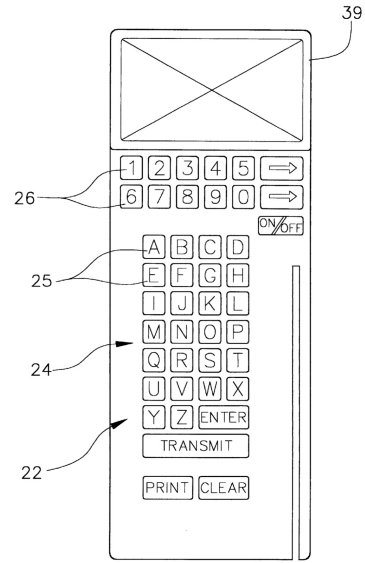

FIG. 2

## CLAIM CONSTRUCTION

### Applicable Law

“It is a ‘bedrock principle’ of patent law that ‘the claims of a patent define the invention to which the patentee is entitled the right to exclude.’” *Phillips v. AWH Corp.*, 415 F.3d 1303, 1312 (Fed. Cir. 2005) (en banc) (quoting *Innova/Pure Water Inc. v. Safari Water Filtration Sys., Inc.*, 381 F.3d 1111, 1115 (Fed. Cir. 2004)). In claim construction, courts examine the patent’s intrinsic evidence to define the patented invention’s scope. *See id.*; *C.R. Bard, Inc. v. U.S. Surgical Corp.*, 388 F.3d 858, 861 (Fed. Cir. 2004); *Bell Atl. Network Servs., Inc. v. Covad Commc’ns Group, Inc.*, 262 F.3d 1258, 1267 (Fed. Cir. 2001). This intrinsic evidence includes the claims themselves, the specification, and the prosecution history. *See Phillips*, 415 F.3d at 1314; *C.R. Bard, Inc.*, 388 F.3d at 861. Courts give claim terms their ordinary and accustomed meaning as understood by one of ordinary skill in the art at the time of the invention in the context of the entire patent. *Phillips*, 415 F.3d at 1312–13; *Alloc, Inc. v. Int’l Trade Comm’n*, 342 F.3d 1361, 1368 (Fed. Cir. 2003).

The claims themselves provide substantial guidance in determining the meaning of particular claim terms. *Phillips*, 415 F.3d at 1314. First, a term’s context in the asserted claim can be very instructive. *Id.* Other asserted or unasserted claims can also aid in determining the claim’s meaning because claim terms are typically used consistently throughout the patent. *Id.* Differences among the claim terms can also assist in understanding a term’s meaning. *Id.* For example, when a dependent claim adds a limitation to an independent claim, it is presumed that the independent claim does not include the limitation. *Id.* at 1314–15.

“[C]laims ‘must be read in view of the specification, of which they are a part.’” *Id.* (quoting *Markman v. Westview Instruments, Inc.*, 52 F.3d 967, 979 (Fed. Cir. 1995) (en banc)). “[T]he specification ‘is always highly relevant to the claim construction analysis. Usually, it is dispositive; it is the single best guide to the meaning of a disputed term.’” *Id.* (quoting *Vitronics Corp. v. Conceptronic, Inc.*, 90 F.3d 1576, 1582 (Fed. Cir. 1996)); *Teleflex, Inc. v. Ficosa N. Am. Corp.*, 299 F.3d 1313, 1325 (Fed. Cir. 2002). This is true because a patentee may define his own terms, give a claim term a different meaning than the term would otherwise possess, or disclaim or disavow the claim scope. *Phillips*, 415 F.3d at 1316. In these situations, the inventor’s lexicography governs. *Id.* Also, the specification may resolve ambiguous claim terms “where the ordinary and accustomed meaning of the words used in the claims lack sufficient clarity to permit the scope of the claim to be ascertained from the words alone.” *Teleflex, Inc.*, 299 F.3d at 1325. But, “[a]lthough the specification may aid the court in interpreting the meaning of disputed claim language, particular embodiments and examples appearing in the specification will not generally be read into the claims.” *Comark Commc’ns, Inc. v. Harris Corp.*, 156 F.3d 1182, 1187 (Fed. Cir. 1998) (quoting *Constant v. Advanced Micro-Devices, Inc.*, 848 F.2d 1560, 1571 (Fed. Cir. 1988)); see also *Phillips*,

415 F.3d at 1323. The prosecution history is another tool to supply the proper context for claim construction because a patent applicant may also define a term in prosecuting the patent. *Home Diagnostics, Inc., v. Lifescan, Inc.*, 381 F.3d 1352, 1356 (Fed. Cir. 2004) (“As in the case of the specification, a patent applicant may define a term in prosecuting a patent.”).

Although extrinsic evidence can be useful, it is “less significant than the intrinsic record in determining the legally operative meaning of claim language.” *Phillips*, 415 F.3d at 1317 (quoting *C.R. Bard, Inc.*, 388 F.3d at 862). Technical dictionaries and treatises may help a court understand the underlying technology and the manner in which one skilled in the art might use claim terms, but technical dictionaries and treatises may provide definitions that are too broad or may not be indicative of how the term is used in the patent. *Id.* at 1318. Similarly, expert testimony may aid a court in understanding the underlying technology and determining the particular meaning of a term in the pertinent field, but an expert’s conclusory, unsupported assertions as to a term’s definition is entirely unhelpful to a court. *Id.* Generally, extrinsic evidence is “less reliable than the patent and its prosecution history in determining how to read claim terms.” *Id.*

**“display being pivotally mounted on said housing”**

Raylon construes the term as “an electronic device attached to a housing that visually presents information and allows the display to be moved or pivoted relative to the viewer’s perspective.” Casio, Complus, and Fujitsu construe the term as “the display must be mounted on the housing and the mounting of the display on the housing must be pivotal so that the display and housing may pivot with respect to each other.” EZ Tag construes the term as “[a]n integral computer screen which can move positions with regard to the computer housing and is not maintained in a fixed position.”

Raylon requires the display be “attached” to the housing so the display is moved or pivoted “relative to the viewer’s perspective.” Defendants’ constructions differ regarding the mounting and movement of the display: EZ Tag’s definition requires that the housing and display are not in fixed positions, while Casio, Complus, and Fujitsu define the display as mounted to the housing so that the housing and display are pivotal with respect to each other.

Raylon’s definition is contrary to the specification and the plain meaning of the claim. The ’589 patent claims require a “display being pivotally mounted on said housing,” and the specification describes the display as “pivotally mounted on the housing.” *See* ’589 patent at 7:30-31 (claim 1), 8:56-57 (claim 16), 9:21-22 (claim 17), Abstract, 1:38-39, 2:11-12, 3:30-32, 5:58-65. However, rather than construing pivotal relative to the housing as described in the patent, Raylon requires that the display be pivotal to the user. Raylon attempts to define “pivotally mounted” broadly enough to include any embodiment that allows the user to move or adjust the screen relative to the viewer’s perspective. Raylon argues that pivotal mounting is the ability to move the screen (e.g. moving one’s arm or wrist to move the entire device) so that the viewer can change the angle of orientation between himself and the display. In other words, any device with a display that can be moved so that the viewer’s perspective is changed, is “pivotally mounted.” However, this is broader than the claim language, which calls for a “display being pivotally mounted on said housing.” Raylon offers a single citation to the specification that discusses pivoting the display so that the user may maintain eye contact while using the device. *See* ’589 patent at 3:42-46 (“Even still another object of the present invention is to provide a new identification investigating and ticket issuing system that permits a police officer to maintain visual contact of a stopped person while investigating whether the person has any warrants or suspended license.”). But this citation fails to sustain Raylon’s

contention that the pivotal motion of the display is relative to the viewer's perspective rather than the housing.

EZ Tag's definition is also broader than the claim language, as it reads out the "pivotal" requirement and further defines "display." The word "display" used within the context of the claims is easily understood and does not require additional definition beyond its plain and ordinary meaning.

The plain language of the claims support Casio, Complus, and Fujitsu's construction: "the display must be mounted on the housing and the mounting of the display on the housing must be pivotal so that the display and housing may pivot with respect to each other." As shown above, Figure 1 of the patent, which illustrates one embodiment of the claims, depicts the display as hinged to the housing and thus pivotal with respect to the housing. The Court declines to import a "hinge" limitation, but defines the term plainly as written and in line with the specification. *See* '589 patent at 5:58-61 ("The display 39 may be pivotally mounted on the housing 12 and may be positioned generally adjacent to the first end 13 of the housing 12."). The Court substantively adopts Casio, Complus, and Fujitsu's construction and defines "display being pivotally mounted on said housing" as "the display must be mounted on the housing so that the display and housing may pivot with respect to each other."

### **SUMMARY JUDGMENT**

The term "display being pivotally mounted on said housing" is case dispositive for all parties. Therefore, following the claim construction hearing, the Court heard argument on Defendants' motions for summary judgment of non-infringement.

In all three cases Raylon accuses Defendants' handheld electronic ticket writers of infringement. For example, Complus supplies four models of the accused ticket writers: Psion



Workabout Pro, Fujitsu TeamPad 500, Casio IT 3000, and Casio IT 3100. All of the devices have display screens that are rigidly mounted in their housing:



Pison Workabout Pro

Fujitsu TeamPad 500

Casio IT 3000

Casio IT 3100

Likewise, Symbol's accused terminals have displays that are rigidly mounted in their housing:



MC50

MC70

At the claim construction hearing, Raylon confirmed that all accused products, in all three cases, have displays that are rigidly mounted as to the housing. Tr. at 23:15-21.

Defendants all assert the same non-infringement argument: because their accused products have rigidly mounted displays on the housing they do not infringe literally or under the Doctrine of Equivalents. Raylon argues that Defendants' displays are not fixed or static displays (e.g. wall-

mounted displays, fixed location displays) because the displays can be tilted, moved, or pivoted with respect to the user's viewpoint by moving one's arm or wrist to move the entire device.

### **Applicable Law**

Summary judgment shall be rendered when the pleadings, depositions, answers to interrogatories, and admissions on file, together with the affidavits, if any, show that there is no genuine issue as to any material fact and that the moving party is entitled to judgment as a matter of law. FED. R. CIV. P. 56(c); *Celotex Corp. v. Catrett*, 477 U.S. 317, 323-25 (1986); *Ragas v. Tenn. Gas Pipeline Co.*, 136 F.3d 455, 458 (5th Cir. 1998). An issue of material fact is genuine if the evidence could lead a reasonable jury to find for the non-moving party. *Anderson v. Liberty Lobby, Inc.*, 477 U.S. 242, 248 (1986). In determining whether a genuine issue for trial exists, the court views all inferences drawn from the factual record in the light most favorable to the nonmoving party. *Id.*; *Matsushita Elec. Indus. Co. v. Zenith Radio*, 475 U.S. 574, 587 (1986).

To prove literal infringement, the patentee must show that the accused device contains every limitation in the asserted claims. *Cybor Corp. v. FAS Techs., Inc.*, 138 F.3d 1448, 1467 (Fed. Cir. 1998) (en banc ). To find infringement under the doctrine of equivalents, any differences between the claimed invention and the accused product must be insubstantial. *Graver Tank & Mfg. Co. v. Linde Air Prods. Co.*, 339 U.S. 605, 608 (1950). The "essential inquiry" in any determination under the equivalents doctrine is whether "the accused product or process contain[s] elements identical or equivalent to each claimed element of the patented invention." *See Warner-Jenkinson Co. v. Hilton Davis Chem. Co.*, 520 U.S. 17, 40 (1997). One way of proving infringement under the doctrine of equivalents "is by showing on a limitation by limitation basis that the accused product performs substantially the same function in substantially the same way with substantially the same result as

each claim limitation of the patented product.” *Id.* at 39-40. However, “[e]quivalence, in the patent law, is not the prisoner of a formula and is not an absolute to be considered in a vacuum.” *Id.* at 24-25 (quoting *Graver Tank*, 339 U.S. at 609).

### **Analysis**

The Court has construed “display being pivotally mounted on said housing” as “the display must be mounted on the housing so that the display and housing may pivot with respect to each other.” All of the independent claims require a “display being pivotally mounted on said housing.” *See* ’589 patent at 7:30-31 (claim 1); 8:56-57 (claim 16); 9:21-22 (claim 17). Each of the accused products, in all three cases, has a fixed display screen. *See* Tr. at 23:15-21. None of the accused products literally meet this claim limitation; therefore, the accused products do not literally infringe.

Likewise, the accused products do not infringe under the Doctrine of Equivalents. The patent describes the display as “pivotally mounted on the housing.” ’589 patent at 5:58-61. The claimed pivotal display functions to pivot a display screen relative to the housing. The claimed invention achieves this function by a pivotally mounting the display to the housing. For example, the depicted embodiment of the patented invention in Figure 1 uses a hinge to attach the display screen to the housing. This results in a display that can be pivoted relative to the housing.

It is undisputed that the accused products all have displays that are fixed and do not move. Tr. at 23:15-21. Raylon argues the equivalent to the pivotal display is any display that can be tilted, moved or pivoted with respect to the user’s viewpoint. However, given that all the accused devices have displays that are rigidly mounted, the accused products do not meet the function, way, result test. First, the fixed display of the accused products do not perform substantially the same function. The displays are rigidly mounted so they cannot move and are thereby incapable of substantially

performing the function of pivoting, tilting, rotating, repositioning, or otherwise moving the display. Likewise, the accused devices do not perform the function in substantially the same way. Being rigidly mounted, the accused devices do not have a joint, attachment, or bearing that allows the display screen to move. Finally, the accused devices do not achieve substantially the same result. The rigidly mounted display in the housing of the accused products cannot pivot or otherwise move relative to the housing as claimed by the invention. Accordingly, the accused devices do not infringe under the Doctrine of Equivalents.

Moreover, Raylon's infringement theory under the Doctrine of Equivalents vitiates that claim limitation by accusing the products of functioning in a way that is opposite to what the claims require. This is legally improper. Raylon's arguments read the "pivotal" claim limitation out of the claims. Thus, based on Raylon's theory of infringement on equivalence, it cannot be determined that the accused products are equivalent to the claimed limitation. *See Warner-Jenkinson Co.*, 520 U.S. at 39 n.8 (1997) ("under the particular facts of a case, . . . if a theory of equivalence would entirely vitiate a particular claim element, partial or complete judgment should be rendered by the court").

Accordingly, during the hearing, the Court granted the motions of non-infringement as to both literal infringement and infringement under the doctrine of equivalents for all parties and accused products, thus disposing all of Raylon's claims. Tr. at 23:22-19, 25:2-25, 26:10-22.

## **CONCLUSION**

As set forth above and as stated at the hearing, the Court **GRANTS** Defendants' motions for summary judgment of non-infringement and dismisses the 6:09cv355, 6:09cv356, 6:09cv357 cases.

**So ORDERED and SIGNED this 23rd day of March, 2011.**

A handwritten signature in black ink, appearing to read 'Leonard Davis', written over a horizontal line.

**LEONARD DAVIS  
UNITED STATES DISTRICT JUDGE**