

EXHIBIT J

CONFERENCE PROCEEDINGS COMBINED VOLUMES

VOLUME I	EXECUTIVE BUSINESS INTERNATIONAL BUSINESS PURCHASING/BUSINESS ISSUES	1
VOLUME II	SOFTWARE & STANDARDS NETWORKS	181
VOLUME III	ENGINEERING TECHNOLOGIES EMERGING TECHNOLOGIES MANUFACTURING PROCESSES	405
VOLUME IV	CAREERS/EDUCATION	891



Wi-LAN v. Alcatel-Lucent, et al.
E.D. Tex. Case No. 6:10-cv-00521-LED

**Defendants' Exhibit
DX-124**

DEFS0011358

Electro '94

Copyright and Reprint Permission: Abstracting is permitted with credit to the source. Libraries are permitted to photocopy beyond the limit of U.S. copyright law for private use of patrons those articles in this volume that carry a code at the bottom of the first page, provided the per-copy fee indicated in the code is paid through the Copyright Clearance Center, 222 Rosewood Drive, Danvers, MA 01923. Instructors are permitted to photocopy isolated articles for noncommercial classroom use without fee. For other copying, reprint, or republication permission, write to IEEE Copyright Manager, IEEE Operations Center, 445 Hoes Lane, P.O. Box 1331, Piscataway, NJ 08855-1331. All rights reserved. Copyright © 1994 by the Institute of Electrical and Electronics Engineers, Inc.

IEEE Catalog Number: 94CH35789
ISBN Casebound: 0-7803-2631-8
Softbound: 0-7803-2630-X
Microfiche: 0-7803-2632-6

Additional copies of this publication are available from:

IEEE Operations Center
445 Hoes Lane
P.O. Box 1331
Piscataway, NJ 08855-1331
USA
1-800-678-IEEE (Members and Individuals)
1-800-701-IEEE (Institutions)
1-908-981-0060 (outside the USA)
1-908-981-9667 (fax)

TABLE OF CONTENTS

VOLUME I
(P2) BUSINESS TRACKS

EXECUTIVE BUSINESS

EB-1: The New Order of Business.....	1
Organizers: Fausto Molinet, Matrix International Franklin Cooper, Marketing Dynamics Corporation	
Chairman: Franklin Cooper, Marketing Dynamics Corporation	
 "The New England Business Climate For The Next Decade" (No manuscript submitted) Katherine Bradbury, Assistant VP & Economist, Federal Reserve Bank of Boston	
 "Defense Conversion and Technology Transfer" - Panel (No manuscripts submitted) Charles Zraket. Former CEO of Mitre/Harvard University James Dunn. President. NASA Center for Technology Transfer Edmund Woollen. VP Corporate Marketing, Raytheon Company	
 "Strategic Alliances" (No manuscript submitted) Bernard Bradstreet, Kurzweil Appield Intelligence	
EB-2: New Processes for Established Businesses.....	3
Organizers: Fausto Molinet, Matrix International Franklin Cooper, Marketing Dynamics Corporation	
Chairman: Franklin Cooper, Marketing Dynamics Corporation	
 "Time To Market Issues (JIT, ISO 9000, TQM) (No manuscript submitted) Bruce Hamilton. VP Operations, United Electric Controls Corporation	
 "Business Process Re-Engineering" (No manuscript submitted) Jose Rodriguez-Soria, President. Q2000 Group	
EB-3: Emerging Businesses.....	5
Organizers: Fausto Molinet, Matrix International Franklin Cooper, Marketing Dynamics Corporation	
Chairman: Fausto Molinet, Matrix International	
 "Financing for Emerging Businesses" (No manuscript submitted) Paul Kelley, Principal Partner, Zero Stage Capital	
 "Marketing for Emerging Businesses" 7 Ralph E. Grabowski, VP of Marketing and Sales for Startups.	

TABLE OF CONTENTS

EB-4: Raising Money With Intellectual Property.....	37
Organizer/Chairman: Joseph S. Iandiorio, Law Offices of Joseph S. Iandiorio	
"Patents, Trademarks, Copyrights & Trade Secrets: What are They and How do They Help Attract Investors?".....	
	39
Joseph S. Iandiorio, Patent Attorney, Law Offices of Joseph S. Iandiorio	
"Raising Money With Intellectual Property".....	
	48
Lawrence H. Gennari, O'Connor, Broude & Aronson	
"The Entrepreneurial View of Intellectual Property and Raising Capital" (No manuscript submitted)	
Paul Severino, President, Wellfleet Communications, Inc.	
EB-5: New England Success Stories (No manuscripts submitted).....	57
Organizers: Fausto Molinet, Matrix International	
Franklin Cooper, Marketing Dynamics Corporation	
Chairman: Peter Meade, CEO, The New England Council	
Joanna Lau, President, Lau Technologies	
Harry Schofield, President, Atlantek, Inc.	
Mitchell E. Kertzman, CEO, Power Soft Corporation	

INTERNATIONAL BUSINESS

"Overview" - A Roadmap To Going International" (No manuscript submitted)	
Herbert Ullman, ExportCom	
IB-1: Forming Partnerships - US and International.....	59
Organizer/Chairman: Donald Welch, Bay Colony Representatives	
"Overview - Opportunities In Global Situations".....	
	61
Donald Welch, Bay Colony Representatives	
"Establishing Partnerships in Southeast Asia".....	
	66
Timothy E. Spino, Venturing Worldwide	
"Form and Fit of an International Business Alliance".....	
	83
John Trogolo, The Alliance Group, Inc.	
"Strategic Global Partnership".....	
	93
John P. Harnick, General Data Communications, Inc.	

TABLE OF CONTENTS

"Getting Massachusetts Products Into The Global Market" (No manuscript submitted)
The Honorable Argeo Paul Cellucci, Lt. Governor of the Commonwealth of Massachusetts

IB-2: Government Support For International Trade - Panel..... 99
Organizer/Chairman: Paula Murphy, Massachusetts Office of International Trade & Investment/Small Business Development Center

"Government Support for International Trade" - Overview (No Manuscript submitted)
Paula Murphy, International Trade Counselor, Massachusetts Office of International Trade & Investment/Small Business Development Center

Moying Li, Assistant Director, Trade Development Unit, Massachusetts Port Authority
Keith Yatsuhashi, Trade Specialist, US Department of Commerce
John Joyce, Regional International Trade Officer, US Small business Administration
Mark Chin, Program Manager, Massachusetts Industrial Finance Agency

IB-3: Trade Finance Workshop.....101
Organizer/Chairman: John Joyce, US Small Business Administration

"Introduction To Export Credit Insurance".....103
John T. Lavelle, Regional Manager, Export-Import Bank of The United States

"Terms of Payment/Trade Services of Private Banks" (No manuscript submitted)
Wayne E. Cook, VP, International Trade & Banking Services

"Massachusetts State Finance Program/International Trade Finance Program of the Export Import Bank" (No manuscript submitted)
Mark Chin, Program Manager, Massachusetts Industrial Finance Agency

"US Small Business Administration Finance Program" (No manuscript submitted)
John P. Joyce, Regional International Trade Officer, US Small Business Administration

IB-4: Europe After Maastricht: Implications for US Business - Panel.....113
Presenter/Chairman: Walter Gerhardt, Consul General of The Federal Republic of Germany

"The Challenges and Opportunities for American Business in The United Germany" (No manuscript submitted)
John F. Curtis, Partner, Ernst & Young

"New Members, New Institutions, New Jobs - The Agenda of the European Union at the Turning of the Century" (No manuscript submitted)
Soren Sondergaard, Deputy Director of Press and Public Affairs, Delegation of the European Union

TABLE OF CONTENTS

"America, Europe and the Pacific Rim - Their Relationship in the Next Century" (No manuscript submitted)
Professor Arpad von Lazar, Professor of International Politics at The Fletcher School of Law and Diplomacy of Tufts University

"Europe After Maastricht: How Can US Business Profit from the New Opportunities" (No manuscript submitted)
Charles Ludolph, Director, Office for European Community Affairs, Department of Commerce

IB-5: NAFTA - Panel (No manuscripts submitted).....115
Organizer/Chairman: Robert Ullman, MIT '94

Norman Fieleke, VP and Economist, Federal Reserve Bank of Boston
James Anderson, Professor of Economics, Boston College
Lucrecia Fernandez-Serrano, Senior Counsel, Home Insurance Company
Kurt F. Jensen, Consul of Canada
Representative of the Mexican Government (not determined at time of publication)

IB-6: Business Strategies In The Americas - Panel (No manuscripts submitted).....117
Organizer/Chairman: Elizabeth Ozon, Director, Canada & Latin America, Massachusetts Office of International Trade & Investment

William A. Burck, Assistant General Counsel, International, Data General Corporation
Cesar O. Andrade, International Sales Manager, Iberoamerican Markets, Boston Technology International
Patricia Grasso, Regional Sales Manager, Latin America, Techexport
Gary R. Wilmarth, President, Trade Advisory Services, Inc.
Paul E. Linet, Customs & International Trade Attorney, Paul E. Linet, R.C.

IB-7: ISO 9000 - Its Effect On Your Company - Panel.....119
Organizer/Chairman: Jerry Kurcher, Manager, Quality Hologic

"ISO 9000 Overview - The International Quality Standard" (No manuscript submitted)
Jack Small, IBM Corporation

"15 Steps to a Successful ISO 9000 Quality Assurance System".....121
Art Ramos, Manager Quality, Millipore/Graham Hill, Tomlin Associates

"Preparing For The Assessment Process" (No manuscript submitted)
Steve Bergerone, Digital Equipment Company

"Significant Factors In The Path To Registration" (No manuscript submitted)
James O'Neil, President, National Quality Assurance

TABLE OF CONTENTS

IB-8: Understanding European and International Safety Standards.....131
Organizer/Presenter: Werner Paster, Managing Partner, Euro Consult, Inc.

"Understanding European and International Safety Standards"133
 Werner Paster, Managing Partner, Euro Consult, Inc.

PURCHASING/BUSINESS ISSUES

PB-1: Strategies For Contract Manufacturing..... 143
Organizer: Christine Loup, Purchasing Management Association of Boston
Chairman: Beth A. Perdue, CP International

"Extending Capabilities Through Contract Manufacturing" 145
 Jeffrey M. Conklin, Beth A. Perdue, CP International

PB-2: Negotiating In a Technical Environment..... 155
Organizer: Christine Loup, Purchasing Management Association of Boston
Presenter: George Harris, Harris Consulting

"Negotiating in a High-Tech Environment" 157
 George L. Harris, Harris Consulting

PB-3: Supplier Management For Non-Buyers (No manuscript submitted)..... 163
Organizer: Christine Loup, Purchasing Management Association of Boston
Presenter: Richard M. Schickling, EG&G, Inc.

**PB-4: Skills & Methods Required For Competitive Product Development In The
 90's.....165**
Organizer/Chairman: Steven Kludt, Pittiglio Rabin Todd & McGrath

"Session Overview" (No manuscript submitted)
 Amram Shapiro, Pittiglio Rabin Todd & McGrath

"Developing Product Strategies For High Technology Companies" (No manuscript submitted)
 Michael McGrath, Pittiglio Rabin Todd & McGrath

"Organizing For Success In Software Product Development" (No manuscript submitted)
 Steven Kludt, Pittiglio Rabin Todd & McGrath

"Software Development At A Baldrige Winner".....16
 Dan Tudahl and Rick Lindner, IBM Corporation

TABLE OF CONTENTS

**VOLUME II
(P3) SOFTWARE AND STANDARDS/NETWORKS TRACKS**

SOFTWARE AND STANDARDS

SS-1: CFI - Its Value To The Design Engineer.....	181
Organizer: Ed Perkins, Digital Equipment Corporation	
Chairman: Donald Cottrell, CAD Framework Initiative	
"An Overview of the CAD Framework Initiative".....	183
Donald Cottrell, CAD Framework Initiative	
"Design Representation" (No manuscript submitted)	
Laurence Brevard, MCC	
"Tool Encapsulation Techniques for Maximizing Interoperability".....	186
Thomas K. Myers, CAD Framework Initiative	
SS-2: CFI - Real Standard For Real Products - Panel (No manuscripts submitted)	
Organizer: Ed Perkins, Digital Equipment Corporation	
Chairman: Donald Cottrell, CAD Framework Initiative	
Kay Paciorek, Viewlogic Systems, Inc.	
Pat Sheridan, Cadence Design Systems	
Ken Willett, Mentor Graphics Corporation	
SS-3: Electronic Data Books - From Concept To Reality - Panel.....	191
Organizer: Ed Perkins, Digital Equipment Corporation	
Chairman: Joseph Flanigan, IBM Corporation	
"Technical Document Exchange Standard" (No manuscript submitted)	
Bob Yench, National Semiconductor Corporation	
"Electronic Commerce of Component Information" (No manuscript submitted)	
Mike Tebo, Sandia National Labs (NIOPDE)	
"Multichip Modules" (No manuscript submitted)	
Randy Harr, Logic Modeling Corporation	
"Multimedia Component Information (No manuscript submitted)	
Steve Evanczuk, Technology Decision Resources	
"Component Database Impact" (No manuscript submitted)	
Ken Belanger, Aspect Development	

TABLE OF CONTENTS

SS-4: CASE Tools.....	193
Organizer/Chairman: Ed Gordon, BData Systems	
"MetaCASE: Dream or Reality".....	195
Charles F. Martin, Charles F. Martin Associates, Inc.	
"CASE for Client/Server" (No manuscript submitted)	
Dan Kara, CASE Trends	
"CASE Tools For The 21st Century" (No manuscript submitted)	
Peter Mager, PSM Associates	
SS-5: Software Quality.....	201
Organizer/Chairman: Ed Gordon, BData Systems	
"C++: Panacea or Placebo".....	203
Edward Gordon, BData Systems	
"Issues in the Testing of Object-Oriented Software".....	211
Edward V. Berard, Berard Software Engineering, Inc.	
"Improving Software Quality Throughout Development" (No manuscript submitted)	
Reed Hastings, Pure Software, Inc.	
SS-6: Software Metrics: State of Practice.....	221
Organizer: James Perry, GTE Government Systems Corporation	
Chairman: Shashi Mehra, Stratus Computer	
"The Role of Measurement in Software Engineering".....	221
David N. Card, Computer Sciences Corporation	
"A Software Metrics Program".....	231
Deborah DeToma and James Perry, GTE Government Systems Corporation	
"Application of a Quantitative Software Metrics Assessment Process to Military Software Development Programs".....	23
John J. McGarry, Cheryl L. Jones, Naval Undersea Warfare Center	
"Software Measurement Experiences - A Communications Industry Perspective" (No manuscript submitted)	
Larry McCarthy, Motorola Codex	
"Software Measurement Experiences - Practitioners Process Metrics" (No manuscript submitted)	
Jack Ward, Hewlett-Packard	

TABLE OF CONTENTS

SS-7: Utilizing STEP To Connect Electronics Design Engineering & Manufacturing - Panel (No manuscripts submitted)..... 25
Organizer: Ed Perkins, Digital Equipment Corporation
Chairman: Donald Yelton, Digital Equipment Corporation

"Session Overview"
 G. Graves, South Carolina Research Authority (SCRA)

"The Step Standard For Product Model Data"
 Jack Corley, South Carolina Research Authority (SCRA)

NETWORKS

NW-1: Desktop Environment..... 253
Organizer/Chairman: Sioux Mallard, Digital Equipment Corporation

"Managing and Supporting Complex Data Networks".....255
 Eduardo I. Kaufmann and Michael Condry, Digital Equipment Corporation

"Operating System As A Network Platform" (No manuscript submitted)
 Craig Davis, Regional System Marketing Manager, Microsoft
 Don Elliot, Architectural System Engineer, Microsoft

NW-2: LAN + WAN..... 261
Organizer/Chairman: Sioux Mallard, Digital Equipment Corporation

"Evolution of the Internet"..... 263
 Steven Moore, O'Reilly Associates

"Integrating WAN's, LAN's and the Desktop" (No manuscript submitted)
 David Yates, Director, Product Marketing, Wellfleet

NW-3: Telecommunications Futures - Panel (No Manuscripts submitted).....267
Organizer/Chairman: Sioux Mallard, Digital Equipment Corporation

Moderator: Bob Rich, Director & Principal Analyst, Data Quest
 Robert McCauley, Corporation Telecommunications Manager, Digital Equipment Corporation
 Robert Taylor, Planning Consultant, Global Network Department, Avantus
 Barry J. Volante, Vice President, Global Project Finance, General Electric
 Hank Miller, Manager, Telecom Strategy, Xerox

TABLE OF CONTENTS

NW-4: Distributed Networks and Systems.....	269
Organizer: Sioux Mallard, Digital Equipment Corporation	
Chairman: Stanley Yeh, AT&T Bell Laboratories	
"Designing Intelligent Network Architectures and Services".....	271
Stanley Yeh, AT&T Bell Laboratories	
"Service Architecture Evolution for Global Networking".....	276
Stanley Yeh and L.A. Russell, AT&T Bell Laboratories	
C.E. Betta and D. Sheinbein, AT&T Network Services Department	
"LEC: Intelligent Networks (NMS) (No manuscript submitted)	
John Clark, Bell Communications Research	
"A Broadband Evolution (NMS) (No manuscript submitted)	
Mike Verma, AT&T Bell Laboratories	
NW-5: New Commercial Spread Spectrum Communications Products - Panel.....	281
Organizer: Sioux Mallard, Digital Equipment Corporation	
Chairman: Donald Greico, Interdigital Communications Corporation	
"Session Overview/Broadband CDMA Wireless Local Access System" (No manual submitted)	
Donald Greico, Interdigital Communications Corporation	
"CDMA For Cellular and PCS".....	283
Edward G. Tiedemann, Jr., QUALCOMM, Inc.	
"Wireless LAN" (No manuscript submitted)	
Robert Rosenbaum, Windata, Inc.	
"Digital Cordless Communications Using Frequency Hopping" (No manuscript submitted)	
Jay Padgett, AT&T	
NW-6: Digital Signal Processing.....	289
Organizer: Sioux Mallard, Digital Equipment Corporation	
Chairman: Ashok Bindra, EE Times	
"DSP Resource Manager Interface and its Role in DSP Multimedia".....	291
Robert Frankel, Spectron Microsystems, Inc.	
"The Personal Sound System".....	299
Kevin Leary, Analog Devices, Inc.	
"The VCOS Multimedia Environment".....	304
Narciso Mera, AT&T Microelectronics	
"The Mwave Technology Platform: Virtual Signal Processing".....	310
Michael T. Vanover, Mwave Group, IBM Microelectronics	

TABLE OF CONTENTS

NW-8: Neural Networks Technology.....	323
Organizer/Chairman: Voula Georgopoulos, Tufts University, Electrical Engineering Dept.	
"Session Overview/The Broad Use of Neural Networks in Real-Time Engineering Systems".....	325
Voula C. Georgopoulos, Tufts University, Electrical Engineering Dept.	
"Combining Rule-Based and Neural Network Approaches in the Fusion of Range and Intensity Signals".....	330
Kyriakos P. Zavoleas, Northeastern University	
"Neural Network Detection of Antiepileptic Drugs from a Single EEG Trace".....	346
Javier Echaz and George Vachtsevanos, Georgia Institute of Technology	
"A High Capacity Content Addressable Memory Architecture".....	352
Dr. Philip D. Henshaw, SPARTA, Inc.	
NW-10: Applications of Neural Networks in Engineering Systems.....	367
Organizer: Voula Georgopoulos, Tufts University, Electrical Engineering	
Chairman: Theodore Iaokimidis, The Mitre Corporation	
"Neural Network Based Predictive Control Systems for Underwater Robotic Vehicles"	369
V.S. Kodogiannis, P.J.G. Lisboa and J. Lucas, University of Liverpool, UK	
"Three Neural Network Based, Sensor Systems for Environment Monitoring"	377
Paul E. Keller, Pacific Northwest Laboratory	
"Fuzzy Logic Controller Design: Target Tracking System and Automobile Control System" ...	383
Sam P. Chaudhuri, Sensor Data Integration, Inc.	
"A Target Detecting Neural Network Architecture for Serial Sensor Data System"	393
Tim L. Overman, Boeing Defense & Space Group	
Ahmed Louri, Electrical & Computer Engineering Dept., University of Arizona	

TABLE OF CONTENTS

VOLUME III
(P4) ENGINEERING TECHNOLOGIES/EMERGING
TECHNOLOGIES/MANUFACTURING PROCESSES TRACKS

ENGINEERING TECHNOLOGIES

ENG-1: EDA Vendor Support For High Speed System, Physical Design (No manuscripts submitted)..... 405
Organizer: Hisham Salami, Digital Equipment Corporation
Chairman: Tom Miller, Cadence Design Systems
Co-Chair: Judy Cerrone, Digital Equipment Corporation

Dr. Zaki Rakib, Cadence Design Systems
 Mark Klein, Mentor Graphics
 Tom Lamarche, PADS Software, Inc.

ENG-2: User-Interface (UI).....407
Organizer: Hisham Salami, Digital Equipment Corporation
Chairman: Amaresan R. Sundaram, Digital Equipment Corporation
Co-Chair: Mani Alagappan, Viewlogic Systems, Inc.

"The User Interface in Viewlogic's Tool Integration Framework"409
 George Deak, Viewlogic Systems, Inc.

"User Interface Design For the Engineer"415
 Craig Wills, Computer Science Department, Worcester Polytechnic Institute

"Highly Visual Information Presentation" (No manuscript submitted)
 Howard Webber, Manager, Advanced Development Workgroup Systems, Digital Equipment Corporation

ENG-3: VHDL.....421
Organizer: Hisham Salimi, Digital Equipment Corporation
Chairman: Harry Sloate, Digital Equipment Corporation

"Specification of Interface Behavior for the Automatic Generation of Bus-Interface Models" ..423
 William P. Birmingham, Ajay J. Daga, Jonathan L. DeKock
 EECS Department, The University of Michigan

"VHDL-based System Simulation and Performance Measurement"439
 Patrick A. McCabe, Honeywell, Inc. Space Systems

"Automatic Synthesis of VHDL Benchmarks to Support Simulation Performance Evaluation"452
 Harold W. Carter, University of Cincinnati

"Status of VHDL International Activities" (No manuscript submitted)
 Hillel Ofek, VHDL International

TABLE OF CONTENTS

ENG-4: Trends and Directions in CAD/CAM, CAE (No manuscripts submitted).....	457
Organizer: Eileen Perez, Digital Equipment Corporation	
Chairman: Bruce L. Jenkins, Daratech, Inc.	
Co-Chair: Thomas J. Greaves, Daratech, Inc.	
ENG-5: Concurrent Engineering: Concepts and Practice.....	459
Organizer: Eileen Perez, Digital Equipment Corporation	
Chairman: Donald Stewart, Concurrency Group	
"The Right Dialogue Between Engineering and Marketing".....	461
Donald Stewart, Concurrency Group	
"Enrollment Management, Managing the Alpha AXP Program".....	468
Peter F. Conklin, Digital Equipment Corporation	
Presented by Ellen Salisbury, Digital Equipment Corporation	
"Predictive Metrics For Concurrent Engineering".....	485
Bradford L. Goldense, Goldense Group, Inc.	
"New Products Introduction Process at Sun Microsystems".....	505
Christopher Nalale, Sun Microsystems	
ENG-6: Inter-Organizational Computer Networking in Electronics Manufacturing....	521
Organizer: Eileen Perez, Digital Equipment Corporation	
Chairman: Dale Worley, Netguide Information Services	
"The Pitfalls of Implementing EDI in Procurement".....	523
George L. Harris, Harris Consulting	
"Automated Supply Chain Management".....	528
Monte Zweben, Red Pepper Software Company	
"Electronic Commerce for the Electronics Industry".....	532
Barbara L. Maia Goldstein, National Institute of Standards and Technology	
"Information Technology, Incentives and the Optimal Number of Suppliers".....	540
J. Yannis Bakos, University of California, Irvine	
Erik Brynjolfsson, Massachusetts Institute of Technology	
"Linking EDI to MRPII to Reduce Cycle Time".....	558
Joe Salemi and Mark Rogers, Motorola Codex EDI Team	
ENG-7: VXI Plug & Play - Panel (No manuscripts submitted).....	571
Organizer: Gordon Robinson, GenRad	
Chairman: Red Aylward, GenRad	
Ron Wolfe, National Instruments	
Robert Cleary, Kinetic Systems Corporation	
David Heyworth, Tektronix, Inc.	
Arlene Meadows, Racal-Dana	

TABLE OF CONTENTS

EMERGING TECHNOLOGIES

ET-1: Parallel Processing Issues and Tools - Panel	573
Organizer/Chairman: Alice Brown, Raytheon Company	
"Perspectives on Parallel Software Development"	575
Carol Nowacki, Kendall Square Research	
"Why is Parallel Computing So Hard?....."	577
Myra Jean Prella, Mitre Corporation	
Dave Lubanko, Raytheon Company	
Janice MacCahon, MasPar Corporation	
James Frankel, Thinking Machines Corporation	
(No manuscript submitted)	
ET-2: Virtual Reality - Panel	585
Organizer/Chairman: Ronald R. Mourant, Northeastern University	
"Affordable Virtual Reality".....	587
Eben Gay, ERG Engineering, Inc.	
"Northeastern University's Virtual Environments Laboratory" (No manuscript submitted)	
Ronald Mourant, Northeastern University	
"The Sound of VR: Apatialized Audio" (No manuscript submitted)	
Mike Joly, Kintek, Inc.	
"Introduction To Cyberspace" (No manuscript submitted)	
Paul Metzger, Reality By Design	
ET-3: 64-bit Computing - Solves the Worlds Most Complex Problems.....	597
Organizer/Chairman: Jerry Haigh, Digital Equipment Corporation	
"64-bit Computing - Solves the Worlds Most Complex Problems".....	599
Jerry Haigh, Digital Equipment Corporation	
"The ODBMS Role in 64 bit Distributed Client-Server Computing".....	603
Andrew E. Wade, Objectivity, Inc.	
"Fractal Compression of Data Structures".....	609
Andre Szykier, Cross/Z International, Inc.	

TABLE OF CONTENTS

"Programming and Porting For a 64-Bit Environment" (No manuscript submitted)
 Christopher C. Fillmore-Gillett, Digital Equipment Corporation

"64-Bit Computing As An Enabler of New Applications" (No manuscript submitted)
 Mike Greenfield, Digital Equipment Corporation

ET-4: Biomedical Engineering: Applications of Nuclear Medicine, Magnetic Resonance Imaging and Laser Systems to Patient Care..... 617
Organizer/Chairman: Sam Fine, Northwestern University
Co-Chairman: Harold Goldberg

"Advances in Nuclear Medicine" (No manuscript submitted)
 Alan Ashare, Chief, Division of Nuclear Medicine, St. Elizabeth Hospital; Associate Professor, Tufts University School of Medicine

"Fast Magnetic Resonance Imaging" (No manuscript submitted)
 Michael Stehling, Beth Israel Hospital/Harvard Medical School

"Lasers in Medicine and Surgery" (No manuscript submitted)
 Rox Anderson, Massachusetts General Hospital; Associate Professor, Harvard Medical School

ET-5: Advances In Imaging For Medicine..... 619
Organizer/Chairman: Sam Fine, Northeastern University

"A New CT Scanner for Emerging Markets".....621
 John McGregor Dobbs, Analogic Corporation

"Computer Assisted Surgery With Magnetic Resonance Imaging" 629
 Ron Kikinis, Director Surgical Planning Laboratory, Bingham & Women's Hospital/Assistant Professor of Radiology, Harvard Medical School

"Positron Emission Tomography: Instrumentation and Applications" (No manuscript submitted)
 John Correia, Massachusetts General Hospital/Associate Professor of Radiology, Harvard Medical School

ET-6: Biomedical Engineering at the Industrial, Hospital and Federal Level.....633
Organizer/Chairman: Sam Fine, Northeastern University

"Clinical Engineering at the New Boston City Hospital"..... 635
 James C. Piepenbrink, Director of Clinical Engineering, Boston City Hospital

"Biomedical Engineering at The Biomedical Engineering and Instrumentation Program, NIH"..... 643
 Henry S. Eden, Associate Chief, Biomedical Engineering and Instrumentation Program, National Institutes of Health

TABLE OF CONTENTS

"Medical Electronics in Clinical Diagnostics: An Emerging Technology With Significant Applications" (No manuscript submitted) Michael Zelin, VP , System Development, I-Stat Corporation	
"Biomedical Engineering in The Hospital" (No manuscript submitted) Daniel Raemer, Director, Biomedical Engineering, Bingham & Women's Hospital/Associate Professor, Harvard Medical School	
ET-7: Emerging Technologies: Special Topics.....	649
Organizer/Chairman: Sohail Hussaini, Cariger, Inc.	
"Simple Bar Graph Displays for Control Variables and Alarm Status".....	651
Sohail Hussaini, Cariger, Inc.	
"Herbie Busters" and Other Novel Methods to Optimize Assembly Equipment".....	657
Murali Mani, Philips CFT-Briarcliff	
"Electronic System Design Automation: From Product Idea To Gates".....	663
David Jakopac, Vista Technologies, Inc.	
"VLSI Implementation of Digital Compensators and Predictive PID Controllers".....	670
Kanti Prasad, Senior Member IEEE/Alex E. Raj, Teaching Assistant for VLSI Labs, Electrical Engineering Department, University of Massachusetts Lowell	

MANUFACTURING PROCESSES

MP-1: Testing - From Chips to System.....	689
Organizer: Gordon Robinson, GenRad, Inc.	
Chairman: John Andrews, National Semiconductor	
"An Embedded JTAG, System Test Architecture".....	691
John Andrews, National Semiconductor	
"A New Technique Uses Digital Patterns to Diagnose Open Pins".....	701
Michael Hamblin, GenRad, Inc.	
"A Chip To Embedded System Test Process".....	728
Joseph E. Kadaras, Mercury Computer Systems, Inc.	
"BIST/BS: A "Champions' View".....	733
Richard L. Campbell, AT&T Engineering Research Center	
"Programming Connections for a Flexible Test System".....	743
Michele Chabot and Lisa Gordon, GenRad, Inc.	
"Why 1149.1 (JTAG) Really Works".....	749
Gordon D. Robinson, GenRad, Inc.	

TABLE OF CONTENTS

MP-2: Using The IEEE 1149.5 Module Test and Maintenance Bus.....	755
Organizer/Chairman: Gordon Robinson, Genrad, Inc.	
"IEEE P1149.5 Standard Module Test and Maintenance Bus".....	757
Pat McHugh, US Army Research Laboratory	
"Interfacing IEEE 1149.1 To IEEE 1149.5"	768
Greg Young, Texas Instruments	
Pat McHugh, US Army Research Laboratory - EPSD	
"An Application of the IEEE 1149.5 MTM-Bus to The Boeing 777" (No manuscript submitted)	
Larry Bashaw, Honeywell	
"The SAE Avionics Test and Maintenance Bus" (No manuscript submitted)	
Dave Heiligenstein, Westar, Inc.	
MP-3: Testability Techniques for Multi-Chip Modules.....	783
Organizer: Gordon Robinson, Genrad, Inc.	
Chairman: Yervant Zorian, AT&T Laboratories	
"The Effective Use of BIST and Boundary-Scan in Multi-Chip Module Testing".....	785
Yervant Zorian, AT&T Laboratories	
"Multichip Module Diagnosis".....	793
Prawat Nagvajara, Drexel University	
"BIST/DFT for Performance Testing of Bare Dies and MCMs".....	803
Chih-Ang Chen and Sandeep K. Gupta, University of Southern California	
MP-4: MCM's.....	813
Organizer: Daniel Bauks, Debur Corporation	
Chairman: Steven K. Ladd, Interchip Systems, Inc.	
"Removal of Wire Bond Die Using a Three Step Process".....	815
Camille Proietti-Bowne, IBM Microelectronics Division	
"MCM C-4 Technologies: AU Bumped KGD".....	820
Peter Elenius, IBM Microelectronics Division	
"Advanced Packaging & Multichip Modules" (No manuscript submitted)	
Steven K. Ladd, President, InterChip Systems, Inc.	
"MCM C-4 Technologies: Rework of Wire Bonded Devices" (No manuscript submitted)	
Duanne Delfosse, VP, Circuitest Services, Inc.	
"AU Bumped KGD" (No manuscript submitted)	
Pete Elenius, Manufacturing Solutions, IBM	

TABLE OF CONTENTS

"C-4 Place and Join" (No manuscript submitted)	
Scott Langenthal Manufacturing Solutions, IBM	
"MCM Testing and Diagnostic Experience" (No manuscript submitted)	
Jed Eastman, Manufacturing Solutions, IBM	
MP-5: Thermal Management.....	827
Organizer: Daniel Bauks, Debur Corporation	
Chairman: Gary Kuzmin, Digital Products Group, Aavid Engineering	
"Oasis Cooling Packaging Technology for Notebook Computers".....	
Gary Kuzmin, Digital Products Group, Aavid Engineering	829
"CVD Diamond Electronic Packaging Applications".....	
Grant Lu, Norton Diamond Film	836
"Diffuser Cooling Technology For Electronic High-Density Packaging".....	
Douglas A. Bailey, Digital Equipment Corporation	840
"High Power Thick Film Circuitry on Pecos (Porcelain Enamel Coating on Steel; Substrates)"..	
Robert Field, Alan Genis, College of Engineering/Engineering Technology, Northern Illinois University - Presented by: Daniel Giesecke, Lawrence Gleason, Ohmite Manufacturing Co.	847
MP-6: Advanced Assembly In Packaging Techniques.....	855
Organizer/Chairman: Daniel Bauks, Debur Corporation	
"Glass Microwave IC Packaging Technology".....	
Richard Perko, M/A-COM, Inc.	857
"Automated Module Fabrication".....	
Nils Bergstrom, Lockheed Sanders	863
"High Speed SMT Connector Technology" (No manuscript submitted)	
Mark Rice, Regional Sales Manager, AUGAT, Interconnection Products Division	
"Optimizing Signal Integrity in High Speed Board to Board Connections" (No manuscript submitted)	
Fabrizio Zanella, Signal Integrity Engineer, TERADYNE, Inc., Connection Systems Division	
MP-7: Polymer Joining Alternatives.....	877
Organizer: Daniel Bauks, Debur Corporation	
Chairman: Ken Gilleo, Alpha Metals	
"Session Overview" (No manuscript submitted)	
Bruce Murray, W.R. Grace	



May 10 - May 12, 1994
Boston, MA

TABLE OF CONTENTS

"The Use of Adhesive Technology in the Replacement of Solder for the Manufacture of the New Fiat 500 Ignition System"	879
R. Barbieri, G. Coppari, Magneti Marelli Electronics Division/D. Rudland, Ablestik EM&A Presented by: Acran Youm, Ablestik Laboratories	
"Successful Case Histories of Polymer Based Circuitry on Flexible Film Substrates"	885
Roger A. Iannetta, Jr. Poly-Flex Circuits, Inc.	
"Testing of Conductive Adhesives: IPC Activities" (No manuscript submitted) Dick Thompson, Loctite	

TABLE OF CONTENTS

VOLUME IV
(P5) CAREERS AND EDUCATION TRACK

CAREERS/EDUCATION

- CE-1: Career Planning for The 1990's - Panel (No manuscripts Submitted)..... 891**
Organizer: John A. Orr, Worcester Polytechnic Institute
Chairman: Leslie Gabriele, Gabriele & Graves
- Bob Rivers. Bose Corporation
Matt Caruso. ChipCom Corporation
- CE-2: Accelerating Profitable Growth: A Winning Plan to Penetrate Global Markets.. 893**
Organizer: John A. Orr, Worcester Polytechnic Institute
Chairman: Tim McGarvey, Eclipse 2000
- "Accelerating Profitable Growth: A Winning Plan to Penetrate Global Markets"..... 895
Tim McGarvey, Eclipse 2000
- CE-3: Engineering Careers in the 90's - Panel (No manuscripts submitted)..... 915**
Organizer: John A. Orr, Worcester Polytechnic Institute
Chairman: Ed U. Lee. Digital Equipment Corporation
- John Travers. Data Arts and Sciences
Sandy Bradshaw. Digital Equipment Corporation
Sally Silver. Sally Silver. Inc.
Deb Murphy. Prime Selecuions
- CE-4: Integrating Diversity In the Workplace - Panel 917**
Organizer: John A. Orr, Worcester Polytechnic Institute
Chairman: Margaret King VanDuyne, One With One. Inc.
- "Initiating a Diversity Program: The Process and Its Risks and Returns"..... 919
Jane M. Donohue. Sterling Bank
- "Introducing Diversity Through Adult Internships"..... 930
Katherine B. Edwards. Coopers and Lybrand
- "Engineers Incorporate Diversity In Their Work" (No manuscript submitted)
Chris Strutt. Engineer. Digital Equipment Corporation
- "Model of Managers and Diversity People Pairing As Partners" (No manuscript submitted)
Margaret King VanDuyne. One With One. Inc.



May 10 - May 12, 1994
Boston, MA

TABLE OF CONTENTS

CE-5: Innovations In Electrical Engineering Education.....	935
Organizer/Chairman: John A. Orr, Worcester Polytechnic Institute	
"A New Introductory Electrical Engineering Curriculum".....	937
John A. Orr, Wilhelm H. Eggimann, Worcester Polytechnic Institute	
"Incorporating Commercial Electronic Design Automation into Electrical and Computer Engineering Curriculum".....	942
Rit Chiang, John Sifferlen and Tak-Goa Tsuei, Merrimack College	
"Engineering Leadership Through Tradition and Innovation".....	953
Edward N. Aqua and Arthur W. Winston, Gordon Institute of Tufts University	

CDMA for Cellular and PCS

Edward G. Tiedemann, Jr.
QUALCOMM Incorporated
San Diego, California USA

Abstract

The Telecommunications Industry Association (TIA) published the North American cellular air interface standard for CDMA cellular communications, IS-95,¹ in 1993 [1]. The Joint Technical Committee (JTC) on Wireless Access, formed between TIA committee TR46 and the Alliance for Telecommunication Solution² (ATIS) committee T1, is drafting an IS-95 based standard for Personal Communications Systems (PCS). The IS-95 standard supports data rates up to 9600 bps; the PCS standard under development supports rates to 14400 bps. Extensions to the PCS standard which will support rates up to 76.8 kbps have been proposed [3]. This paper describes the history of CDMA development, various CDMA cellular standards, the PCS standards under development, and the extended PCS system.

1. Introduction

In the Fall of 1989, the first experiments using cellular CDMA at 800 MHz were conducted in San Diego, California. Based upon the success of these experiments, a preliminary common air interface was developed in conjunction with several cellular carriers and manufacturers.

¹For shortness, this paper omits EIA/TIA or TIA/EIA from the front of an interim standard's number. Thus IS-95 is formally written as TIA/EIA/IS-95.

²Previously the Exchange Carriers Standards Association.

During the Fall of 1991, a large scale test was conducted in San Diego. This test showed that a CDMA system could provide high quality and a capacity greater than ten times the capacity of the existing AMPS cellular system. In the Winter and Spring of 1992, the Cellular Telecommunications Industry Association (CTIA) conducted a series of open forums on wideband technologies. The CTIA also requested that the Telecommunications Industry Association (TIA) develop a wideband standard.

The first PCS operation of CDMA was in Munster, Germany in the Spring of 1992 at 1.7 GHz. This system consisted of a microcell embedded inside and on the same frequency as an umbrella macrocell. Since then there have been numerous CDMA PCS trials in the United States.

2. Cellular Standards

In March 1992, the TIA began the development of the IS-95 wideband standard for 800 MHz cellular radio systems by forming TIA subcommittee TR45.5. In July 1993, the TIA published IS-95, titled *Mobile Station-Base Station Compatibility Standard for Dual-Mode Wideband Spread Spectrum Cellular System*.

When using the traffic channel, IS-95 consists of three protocol stacks (primary traffic, secondary traffic, and signaling traffic) which connect to the multiplex sublayer as shown in Figure 2-1. The multiplex sublayer combines these streams on a per frame basis (20 ms duration) in a manner specified by the multiplex sublayer

rules. Signaling for call setup, registrations, short messages, and other overhead functions are handled via a pair of channels called the Paging and Access Channels. IS-95 standardizes the basic foundation of the system, consisting of layer 1 (physical layer), the multiplex sublayer, the traffic channel signaling protocol stack, and the Paging Channel and the Access Channel protocol stack.

The multiplex sublayer provides a set of connections to which various service options can be connected. The first service option that TIA subcommittee TR45.5 developed is called Service Option 1 and is variable rate voice at rates of 8550, 4000, 2000, and 800 bps. This standard is called IS-96 and is titled *Speech Service Option Standard for Wideband Spread Spectrum Digital Cellular System*.

Thus the pair of documents IS-95 and IS-96 form the core standards for a cellular system providing voice service. In scope they are equivalent to other TIA standards, notably EIA/TIA-553 for analog and IS-54-B for TDMA. The TIA subcommittee TR45.5 is completing a data standard, IS-99, which provides for asynchronous data and fax communications over the CDMA system. For asynchronous data, the mobile station resembles a wireline modem which processes standard "AT" commands (see EIA/TIA-602). For fax, the mobile station resembles a group 3, class 2.0 digital fax modem as standardized in EIA/TIA-592. A notebook computer, PDA, or other device can connect to the mobile station via a standard EIA-232 connection or can have CDMA transmission equipment embedded in it, such as in a PCMCIA card. For both asynchronous data and fax, data is transferred digitally over the wireless link between the mobile station and an interworking function (IWF) in the network equipment. The wireline modem is located

in the IWF and is allocated to a mobile station on a per call basis.

IS-98 and IS-97 are a pair of companion documents to IS-95 providing minimum performance requirements for mobile stations and base stations respectively. These two documents provide a function similar to TIA standards IS-19 and IS-20 for analog and IS-55 and IS-56 for TDMA. Minimum speech coder performance requirements are specified in IS-125, similar in scope to the IS-85 standard that the TIA developed for TDMA.

A different TIA subcommittee, TR45.2, has responsibility for intersystem operations and has developed the IS-41 series of standards. TR45.2 has recently completed TSB-64³ containing modifications for CDMA intersystem handoff. These modifications were needed to specify the CDMA channel assignment and to support CDMA mobile assisted handoff.

3. Scope of IS-95

IS-95 analog operation is compatible with base stations conforming to EIA/TIA-553. In addition, IS-95 analog operation supports analog enhancements added into IS-54-B such as calling number identification, authentication, and message encryption.

The basics of the IS-95 physical layer have been described in [2] and, due to space, are not repeated here. Unlike TDMA, the IS-95 standard is being introduced with a full set of digital control channels. A single CDMA frequency can support up to 7 Paging Channels, operating at either 4800 bps or 9600 bps, for communications from the base station to the mobile station. Paging Channels can also be included on different

³Technical Standards Bulletin Number 64.

CDMA frequencies. The Paging Channel is divided into slots of 80 ms duration. A mobile station need only listen for pages in its assigned slots. The base station can indicate that it has no more messages for mobile stations operating in the slotted mode, thus allowing these mobile stations, typically portables, to power down early in the slot further increasing battery life. For a mobile station, the period of slot repetition, called the slot cycle, is $0.08 \times 2^{N+4}$ seconds where N is from 0 though 7. The mobile station can select the period of its assigned slots by registering with the value of N that it is using. The mobile station uses a series of three hash functions to select the CDMA frequency to use, the Paging Channel on the frequency, and the slot in its specified slot cycle to monitor. Similarly, the base station performs the hashing to determine the frequency, Paging Channel, and slot in which to send a page.

The control channel used for communications from the mobile station to the base station is called the Access Channel, is slotted, and uses a fixed 4800 bps rate. For each Paging Channel, a system can be configured to support up to 32 Access Channels. Each Access Channel is characterized by a different spreading code. Before making an access, the mobile station pseudo-randomly chooses one of the Access Channels that the base station supports. Multiple mobile stations can transmit into the same slot on the same Access Channel. Since transmissions on the Access Channel having arrival times at the base station separated by more than the anticipated multipath spread can be distinguished by the demodulator, collisions in the Aloha sense are infrequent. In addition, the base station can have mobile stations randomize their timing to further avoid collisions. IS-95 also supports backoff procedures for

channel congestion control in cases of overload.

IS-95 supports authentication, message encryption, and voice privacy procedures similar to those used by IS-54-B. As a result, the network's protocols can be identical to those used to support IS-54-B mobile stations.

4. PCS

In the fall of 1993, seventeen PCS air interface standards proposals were submitted to the T1P1.4/TR46.3.3 Joint Technical Committee (JTC) on Wireless Access. Proposals based on IS-95 modifications were submitted by Motorola/QUALCOMM (a joint proposal), AT&T, and OKI. Most of the seventeen original proposals which advocated similar technologies have consolidated into one proposal. At this writing, eight technology ad hoc groups (TAGSs) are working on eight different PCS air interface standards. It is expected that several of these groups will drop out.

The joint Motorola/QUALCOMM proposal advocated a two phased approach to a CDMA PCS air interface. The first phase was to develop a core PCS system. This core system would then be extended to obtain even higher data rates as shown in Table 4-1.

The core system makes several key modifications to the IS-95 system for the 1.8 to 2.2 GHz PCS band. One modification provides support for a 14.4 kbps rate set. This permits use of a voice codec with quality similar to 32 kbps ADPCM. In addition, it allows higher rate data services. Early deployments in the 1.8 GHz to 2.2 GHz band will have to contend with existing microwave systems, called OFS (other fixed services). This is unlike the cellular frequency band where the cellular

carriers have exclusive use of their allocated spectrum. The proposed IS-95 based PCS standard has additional capabilities for handling OFS.

Figure 4-1 shows a simplified view of the modulation and coding for a Forward Traffic Channel in IS-95 and the core PCS system—the differences between them occur in the convolutional encoder. For the 1200, 2400, 4800, and 9600 bps rates, a straight rate 1/2 convolutional code is used. For rates lower than 9600 bps, the convolutional encoder repeats symbols so that each symbol appears 8, 4, 2, or 1 times for the 1200, 2400, 4800, and 9600 bps rates respectively. For the 1800, 3600, 7200, and 14400 bps rates, the symbol repetition output is punctured to produce an equivalent of a rate 3/4 code. The output rate of the convolutional encoder for all rates is 19200 symbols per second.

Each forward channel is assigned to one of a set of orthogonal covering codes. The orthogonal covering codes are the set of 64-ary Walsh functions. In the absence of multipath, the transmissions from different forward channels on the same frequency from the same base station do not interfere with each other.

The extended PCS system adds higher rates via a technique called overlay encoding. Overlay encoding adds additional orthogonal channels in phase quadrature to the existing channels and provides a clever way of merging orthogonal channels to obtain higher rates. A simplified block diagram of the extended system is shown in Figure 4-2. Note the addition of the overlay encoder block. The overlay encoding process is illustrated in Figure 4-3 for the 1.25 mode (1.23 MHz bandwidth). This shows that as the peak transmission rates increase on the Forward Traffic Channel, then fewer codes are available. For example, there can be 32

Forward Traffic Channels assigned at 38.4 kbps. Some of these 32 channels can also be split; for example, there can be 16 channels assigned at 38.4 kbps and 64 channels assigned at 9600 bps. The information carrying capacity of the channel may limit the actual number of assignments. For example, an IS-95 system can support at least 20 Traffic Channels at 9600 bps using normal voice activities. Assuming the same voice activities, 13 Traffic Channels could be supported using the 1.25 mode at the 14400 bps rate.

The extended system proposes use of a 2.46 MHz spreading bandwidth for the 76.8 kbps rates. To the first order, a spreading bandwidth twice as wide allows for twice the number of users. However, since there are two of the original channels, the net number of users is the same. A larger bandwidth does allow some additional capacity in that the statistical averaging of the voice activity is somewhat better. For the lower transmission rates, there is only a small increase in capacity. However, at higher rates, such as 76.8 kbps, this capacity increase becomes more substantial. For this reason, the extended PCS system shifts to higher a spreading bandwidth for 76.8 kbps. There are also some disadvantages to having a wider spreading bandwidth: First, avoidance of the OFS (microwaves) becomes more difficult. Second, wider spreading bandwidths also make it more difficult or impossible to support private systems such as in office buildings. These first two reasons are particularly true for the 10 MHz (5 MHz for transmit and 5 MHz for receive) wide spectral allocations in the 2.2 GHz band. Third, wider bandwidths also lead to more complex receivers as they must recover additional multipath rays. Finally, in-building multipaths range from about 10 to 100 ns. The FCC has not

assigned sufficient bandwidth to PCS to counteract the in-building fading by a higher bandwidth system.

Since the Reverse CDMA Channel is from many mobile stations to a cell, the IS-95 Reverse CDMA Channel has somewhat different modulation and coding. Similar techniques to those described above for the Forward CDMA Channel provide for higher rates on the Reverse CDMA Channel. These techniques and additional information on IS-95 can be found in [1, 3].

5. References

- [1] TIA/EIA/IS-95, *Mobile Station-Base Station Compatibility Standard for Dual-Mode Wideband Spread Spectrum Cellular System*, Telecommunications Industry Association, Washington, D.C., July 1993.
- [2] Tiedemann, E. G., Salmasi, A.B., and Gilhousen, K.S., "The Design and Development of a Code Division Multiple Access (CDMA) System for Cellular and Personal Communications," IEEE International Symposium on Personal, Indoor, and Mobile Communications, London, England, pp. 131-136, September 1991.
- [3] T1P1.4/TR46.3.3 Joint Technical Committee on Wireless Access, Contribution JTC(AIR)/94.11.01-404, "The CDMA PCS System Common Air Interface Proposal," submitted by QUALCOMM Incorporated and Motorola Incorporated, November 1994.

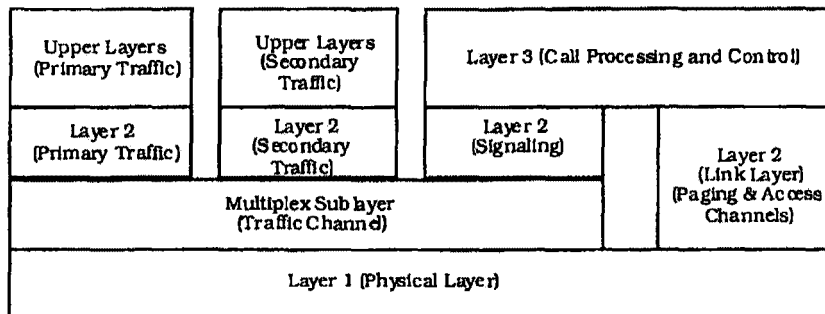

Figure 2-1. Layering in the CDMA Standard

Table 4-1. Summary of the Core and Extended PCS System

Attribute	Core System	Extended System
Bandwidth	1.23 MHz	1.23 MHz (1.25 mode) 2.46 MHz (2.5 mode)
Transmission rates	14400, 7200, 3600, 1800, 9600, 4800, 2400, & 1200 bps	1.25 mode: adds 19.2 & 38.4 kbps 2.5 mode: also adds 76.8 kbps
Voice service rates	4, 8, and 13 kbps	adds 16 and 32 kbps
Data service rates	All up to 14.4 kbps	1.25 mode: adds 19.2 & 38.4 kbps 2.5 mode: adds 76.8 kbps

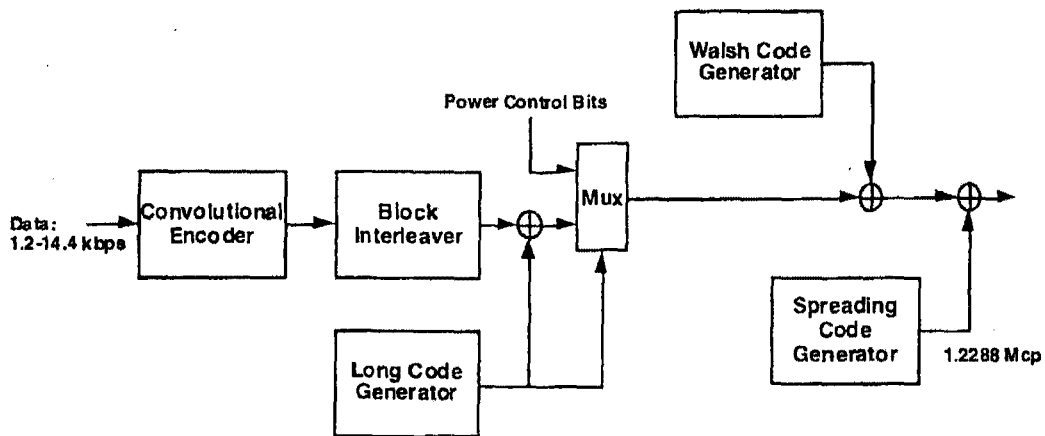

Figure 4-1. Simplified View of the Core System Forward Traffic Channel

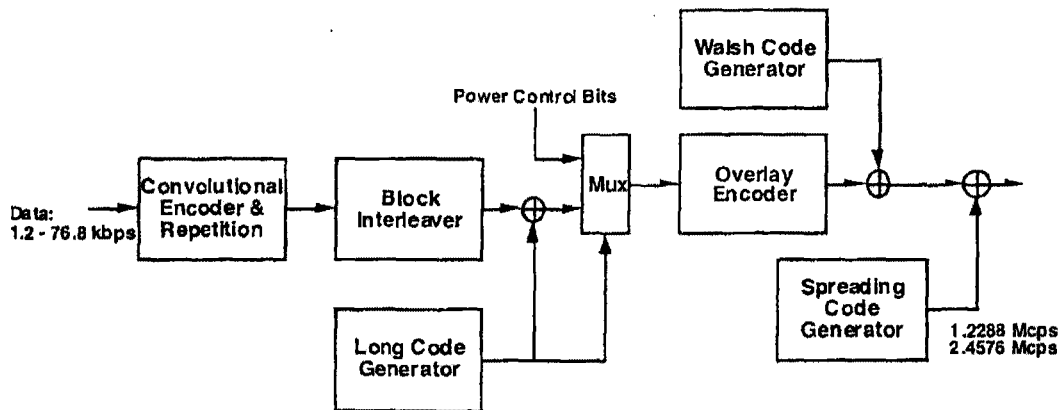

Figure 4-2. Simplified View of the Extended System Forward Traffic Channel

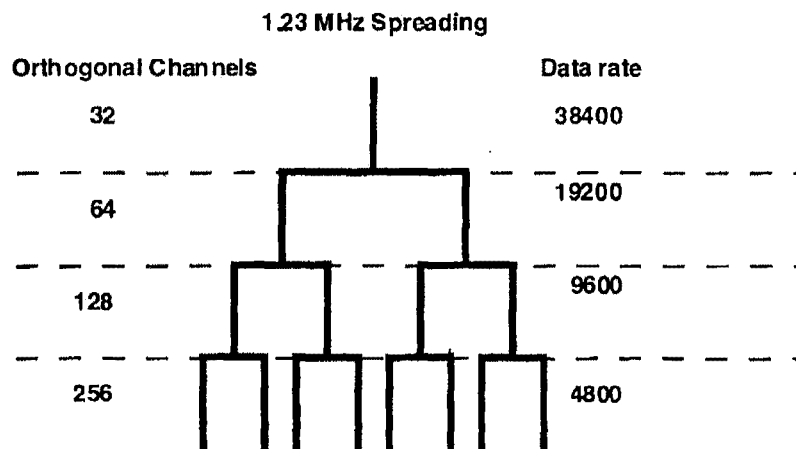

Figure 4-3. Overlay Encoding on the Forward Traffic Channel