

**IN THE UNITED STATES DISTRICT COURT
FOR THE EASTERN DISTRICT OF TEXAS
TYLER DIVISION**

EVM SYSTEMS, LLC,	§	
	§	
Plaintiff,	§	
	§	CASE NO. 6:13-CV-184
v.	§	
	§	
REX MEDICAL, L.P. and ARGON	§	JURY TRIAL DEMANDED
MEDICAL DEVICES, INC.,	§	
	§	
Defendants.	§	

MEMORANDUM OPINION AND ORDER

This Memorandum Opinion construes the disputed claim terms in U.S. Patent No. 8,052,670 (“the ’670 Patent”).

BACKGROUND

EVM Systems, LLC (“EVM”) alleges that Rex Medical, L.P. and Argon Medical Devices, Inc. (collectively “Defendants”) infringe claims 1, 2, 4, 9, 10, and 11 of U.S. Patent No. 8,052,670 (“the ’670 Patent”). The ’670 Patent, titled “Medical Device with Slotted Memory Metal Tube,” relates to medical instruments made with shape memory tube that may be used during endoscopic procedures. On January 16, 2014, the Court conducted a *Markman* hearing regarding the disputed ’670 Patent claim terms.

APPLICABLE LAW

“It is a ‘bedrock principle’ of patent law that ‘the claims of a patent define the invention to which the patentee is entitled the right to exclude.’” *Phillips v. AWH Corp.*, 415 F.3d 1303, 1312 (Fed. Cir. 2005) (en banc) (quoting *Innova/Pure Water Inc. v. Safari Water Filtration Sys., Inc.*, 381 F.3d 1111, 1115 (Fed. Cir. 2004)). In claim construction, courts examine the patent’s intrinsic evidence to define the patented invention’s scope. *See id.*; *C.R. Bard, Inc. v. U.S.*

Surgical Corp., 388 F.3d 858, 861 (Fed. Cir. 2004); *Bell Atl. Network Servs., Inc. v. Covad Commc'ns Group, Inc.*, 262 F.3d 1258, 1267 (Fed. Cir. 2001). This intrinsic evidence includes the claims themselves, the specification, and the prosecution history. See *Phillips*, 415 F.3d at 1314; *C.R. Bard, Inc.*, 388 F.3d at 861. Courts give claim terms their ordinary and accustomed meaning as understood by one of ordinary skill in the art at the time of the invention in the context of the entire patent. *Phillips*, 415 F.3d at 1312–13; *Alloc, Inc. v. Int'l Trade Comm'n*, 342 F.3d 1361, 1368 (Fed. Cir. 2003).

The claims themselves provide substantial guidance in determining the meaning of particular claim terms. *Phillips*, 415 F.3d at 1314. First, a term's context in the asserted claim can be very instructive. *Id.* Other asserted or unasserted claims can also aid in determining the claim's meaning because claim terms are typically used consistently throughout the patent. *Id.* Differences among the claim terms can also assist in understanding a term's meaning. *Id.* For example, when a dependent claim adds a limitation to an independent claim, it is presumed that the independent claim does not include the limitation. *Id.* at 1314–15.

“[C]laims ‘must be read in view of the specification, of which they are a part.’” *Id.* (quoting *Markman v. Westview Instruments, Inc.*, 52 F.3d 967, 979 (Fed. Cir. 1995) (en banc)). “[T]he specification ‘is always highly relevant to the claim construction analysis. Usually, it is dispositive; it is the single best guide to the meaning of a disputed term.’” *Id.* (quoting *Vitronics Corp. v. Conception, Inc.*, 90 F.3d 1576, 1582 (Fed. Cir. 1996)); see also *Teleflex, Inc. v. Ficoso N. Am. Corp.*, 299 F.3d 1313, 1325 (Fed. Cir. 2002). This is true because a patentee may define his own terms, give a claim term a different meaning than the term would otherwise possess, or disclaim or disavow the claim scope. *Phillips*, 415 F.3d at 1316. In these situations, the inventor's lexicography governs. *Id.* Also, the specification may resolve ambiguous claim

terms “where the ordinary and accustomed meaning of the words used in the claims lack sufficient clarity to permit the scope of the claim to be ascertained from the words alone.” *Teleflex, Inc.*, 299 F.3d at 1325. But, “[a]lthough the specification may aid the court in interpreting the meaning of disputed claim language, particular embodiments and examples appearing in the specification will not generally be read into the claims.” *Comark Commc’ns, Inc. v. Harris Corp.*, 156 F.3d 1182, 1187 (Fed. Cir. 1998) (quoting *Constant v. Advanced Micro-Devices, Inc.*, 848 F.2d 1560, 1571 (Fed. Cir. 1988)); see also *Phillips*, 415 F.3d at 1323. The prosecution history is another tool to supply the proper context for claim construction because a patent applicant may also define a term in prosecuting the patent. *Home Diagnostics, Inc., v. Lifescan, Inc.*, 381 F.3d 1352, 1356 (Fed. Cir. 2004) (“As in the case of the specification, a patent applicant may define a term in prosecuting a patent.”).

Although extrinsic evidence can be useful, it is “less significant than the intrinsic record in determining the legally operative meaning of claim language.” *Phillips*, 415 F.3d at 1317 (quoting *C.R. Bard, Inc.*, 388 F.3d at 862). Technical dictionaries and treatises may help a court understand the underlying technology and the manner in which one skilled in the art might use claim terms, but technical dictionaries and treatises may provide definitions that are too broad or may not be indicative of how the term is used in the patent. *Id.* at 1318. Similarly, expert testimony may aid a court in understanding the underlying technology and determining the particular meaning of a term in the pertinent field, but an expert’s conclusory, unsupported assertions as to a term’s definition is entirely unhelpful to a court. *Id.* Generally, extrinsic evidence is “less reliable than the patent and its prosecution history in determining how to read claim terms.” *Id.*

AGREED CLAIM TERMS

In the Joint Claim Construction Chart (Docket No. 51) the parties agreed that the following phrases do not require construction:

Claim Term	Agreed Construction
the expandable section being free of interior structure that is axially movable within the expandable section to expand and/or contract the expandable section	No construction is necessary.
an outer tube that surrounds at least the expandable section of the monolithic memory metal tube and which cooperates with said memory metal tube during expansion and/or contraction thereof	No construction is necessary.
one of the openings forms a slot parallel to the central longitudinal axis of the metal tube	No construction is necessary.
openings are slots	No construction is necessary.

DISPUTED CLAIM TERMS

the metal tube including at least one of a memory effect and superelasticity and having at least one expandable section with a plurality of metal members separated by openings and capable of contraction and expansion to an expanded shape

EVM proposes that no construction is necessary, but alternatively proposes “a hollow metal elongated cylindrically-shaped structure . . . having at least one expandable section with a plurality of members separated by openings and capable of contraction and expansion to an expanded shape.” Defendants propose “the metal tube has within it at least one expandable portion with a plurality of members separated by openings, the expandable portion is capable of contraction and expansion to an expanded shape, wherein when the expandable portion is in its expanded shape position, there remain tube portions both above and below the expandable portion.”

EVM's alternative proposed construction mirrors the claim language except that it defines the metal tube as "a hollow metal elongated cylindrically-shaped structure." This definition does not clarify the claim's use of the word "tube." It is therefore rejected.

Defendants' proposed construction uses "expandable *portion*" in place of "expandable *section*," specifies that only the expandable section of the tube is capable of contraction and expansion, and requires the expandable section to be bound on both sides by non-expandable sections. First, Defendants do not explain their use of "expandable *portion*" in place of "expandable *section*." *See* Docket No. 47 at 5–9. Second, they do not explain the need to specify that only the expandable section of the tube, rather than the tube as a whole, is capable of contraction and expansion. *See id.* Therefore, those proposals are rejected.

The parties dispute the remaining limitation in Defendant's proposed construction, that the expandable section must always be bound on both sides by non-expandable sections. EVM identifies several embodiments with expandable sections that are unbound on one end. Docket No. 45 at 8 (citing '670 Patent Figs. 6A, 7A, 7B, 8, 9C). Defendants counter that the patentees disclaimed those embodiments during prosecution when they made an election following a restriction requirement. Docket No. 47 at 5–6. The restriction requirement instructed the patentees to elect one of twelve distinct species the examiner identified in the original application. Docket No. 47, Ex. 3 at 4–5. Defendants allege the patentees elected to prosecute the species representing the retrieval basket described in Figures 1A through 1D. Defendants argue that based on this election, the patentees disclaimed all subject matter described in the specification directed to any device other than the retrieval basket. Docket No. 47 at 7. They contend patentees cemented their disclaimer when, in response to rejections over prior art, they added claim limitations defining the structure and operation of the retrieval basket. *Id.* Since the

only retrieval basket embodiment in the specification is bound on both sides by non-expandable sections, Defendants assert that patentees disclaimed the embodiments with one or more unbound expandable sections.

Prosecution history can often inform the meaning of claim language. *Plantronics, Inc. v. Aliph, Inc.*, 724 F.3d 1343, 1350 (Fed. Cir. 2013). However, there is “a heavy presumption that claim terms carry their full ordinary and customary meaning” *Epistar Corp. v. Int’l Trade Com’n*, 566 F.3d 1321, 1334 (Fed. Cir. 2009). Therefore, importing limitations from the prosecution history into the claims at the *Markman* stage requires a “clear and unmistakable” disavowal of claim scope during prosecution. *Plantronics*, 724 F.3d at 1350. “Absent evidence of a clear disavowal in the prosecution history, the Court should not deviate from the claim meanings compelled by the remainder of the intrinsic evidence.” *Colorquick, LLC v. Eastman Kodak Co.*, No. 6:06-CV-390, 2008 WL 5771324, at *9 (E.D. Tex. June 25, 2008).

Electing an invention in response to an ambiguous restriction requirement is not a clear disavowal of claim scope. *See Plantronics*, 724 F.3d at 1351. A restriction is merely an administrative tool to control research filing fees and caseload management. *R2 Med. Sys., Inc. v. Katecho, Inc.*, 931 F. Supp. 1397, 1438 (N.D. Ill. 1996). It does so by requiring claims to be divided among more than one application, without addressing patentability. *Id.*

The restriction requirement at issue in this case divided the figures of the ’670 Patent into twelve patentably distinct species, asserting that the claims to those species recite “mutually exclusive characteristics.” Docket No. 47, Ex. 3 at 4–5. This restriction was ambiguous because it did not describe those mutually exclusive characteristics. Moreover, it is clear that the division was not based on the presence or absence of unbound expandable sections. This is obvious

because the species encompassing Figures 9A through 9C discloses embodiments both with and without unbound expandable sections.

Furthermore, while the patentees elected the species of Figures 1A through 1D without traverse, they disagreed with the examiner's position that no claims were generic. *Id.* at 5. The patentees contended that “[c]laim 1 is generic to all species.” Docket No. 47, Ex. 4 at 7. Accordingly, the patentees' election following restriction and the corresponding exchange with the PTO does not amount to a “clear and unmistakable” disavowal of claim scope. Thus, the patentees' election to prosecute the species representing the retrieval basket described in Figures 1A through 1D does not preclude the resulting patent from incorporating unbound expandable sections.

Although Figures 1A through 1D disclose an expandable section that is bound on both sides by non-expandable sections, the claims are not limited to that embodiment. *See Playtex Products, Inc. v. Procter & Gamble Co.*, 400 F.3d 901, 908 (Fed. Cir. 2005) (“Claims of a patent may only be limited to a preferred embodiment by the express declaration of the patentee . . .”). The specification explicitly states that the disclosed embodiments are merely preferred. *E.g.*, '670 Patent cols. 6:48–52 (“Although several embodiments of the present invention have been illustrated . . . the invention is not limited to the embodiments disclosed . . .”). Moreover, the patent discloses additional embodiments, several of which have unbound expandable sections. *See* '670 Patent Figs. 6A, 7A, 7B, 9C; '670 Patent cols. 4:39–40, 4:55–56; 5:40. The specification makes clear that the expandable section can be in different locations along the device. *See, e.g.*, '670 Patent col. 2:59–61 (“The slotted section can be made in several places along the length of the memory metal tube . . .”); '670 Patent, Abstract (The expandable section

can be “near or at the distal end of the instrument . . .”). Accordingly, the expandable section is not required to be bound on both sides by non-expandable sections.

As the Court has resolved the parties’ claim scope dispute, the claim language itself is otherwise clear and would be easily understandable to a juror in the context of the claims at issue. Accordingly, the term “the metal tube including at least one of a memory effect and superelasticity and having at least one expandable section with a plurality of metal members separated by openings and capable of contraction and expansion to an expanded shape” does not require construction.

a retrieval basket for retrieving particles to be removed from the human body

EVM proposes that no construction is necessary, but alternatively proposes “structure resembling a basket that can catch a solid particle.” Defendants propose “the expanded section forms a retrieval basket whose purpose is and which is used to fetch a solid particle to be taken out of the human body by removing the device from the human body while the solid particle is contained in the retrieval basket.” This construction raises two issues: (1) whether “retrieval basket” requires construction and (2) whether “retrieving *particles* to be removed from the human body” requires removing the *device* from the human body.

First, EVM proposes that no construction is necessary, and alternatively uses dictionary definitions to support a plain and ordinary meaning of “retrieval basket.” Docket No. 45 at 9–10. Defendants contend that the claim language surrounding “retrieval basket” explicitly defines its structure within the metal tube. Docket No. 47 at 10. Defendants are correct. Claim 1 recites that the metal tube has “at least one expandable section with a plurality of metal members separated by openings and capable of contraction and expansion to an expanded state to form a

retrieval basket.” ’670 Patent, claim 1, col. 7:8–13. Accordingly, there is no need to construe “retrieval basket.”

Second, Defendants argue that the claims, specification, and prosecution history require the retrieval basket to be removed from the human body. Docket No. 47 at 12–17. They contend the claim language explicitly recites that the expandable section is used “for retrieving particles to be removed from the human body[.]” *Id.* at 11 (citing ’670 Patent, claim 1, col. 7:13–14). However, the language requiring the removal of particles does not necessarily implicate the removal of the device.

Defendants also assert that an embodiment describing the relative axial movement between the delivery and memory metal tubes shows that the device must be removed from the human body. *Id.* at 12 (citing ’670 Patent col. 3:37–41). But relative axial movement between those tubes merely “enables the expansion or the contraction of the memory metal tube.” ’670 Patent col. 3:40–41. It does not disclose removing the tube from the body.

Similarly, Defendants argue that Figure 1B, which shows the diameter of the solid particle being larger than that of the metal tube, indicates that the retrieval basket must be removed from the human body. Docket No. 47 at 12. However, as EVM correctly states, there are other possibilities for removing the particle after it is caught, such as dissolution. Docket No. 49 at 4–5. Moreover, claims are not limited to only the embodiments illustrated in the specification and there is nothing in the specification that explicitly discusses removing the device from the human body after the particle is caught.

Defendants further argue that the prosecution history requires the retrieval basket to be removed from the human body. After an anticipation rejection in light of U.S. Patent No. 5,456,667 (the “Ham Patent”), the patentees added the limitation “to form a retrieval basket for

retrieving particles to be removed from the human body.” Docket No. 47 at 14. The device disclosed in the Ham Patent pressed “flaps” against the arterial wall until they reattached. Docket No. 47-20 col. 7:39–67 (Ham Patent). The patentees’ amendment distinguishes the claimed invention’s treatment of “particles” from the Ham Patent’s disclosed treatment of the “flaps”—the particles are to be removed, instead of pressed against the arterial wall until they reattach. Although this amendment requires the particles to be removed, it does not require removal of the retrieval basket. Therefore, Defendants’ proposal to require the particle to be taken out of the human body “by removing the device from the human body” would add an improper claim limitation. However, the Court clarifies that the claim term requires that the particle is removed somehow.

Here, the claim language itself is clear and would be easily understandable to a juror in the context of the claims at issue. Accordingly, the Court finds that “a retrieval basket for retrieving particles to be removed from the human body” does not require construction.

distal end

EVM proposes that no construction is necessary, but alternatively proposes “end of the tube located furthest downstream.” Defendants propose “terminal end of the expandable section.” The parties dispute whether the distal end refers to the end of the tube or the end of the expandable section, and the orientation of the distal end.

First, EVM argues the distal end refers to the end of the tube, whereas Defendants contend it refers to the end of the expandable section. In some instances, the specification uses “distal end” to refer to the end of the tube.¹ In another instance, the specification refers to the

¹ *E.g.*, ’670 Patent, Abstract (“the distal end of the instrument”); ’670 Patent col. 2:27 (“the distal end of the instrument”); ’670 Patent col. 3:32–33 (“a memory metal tube 11 with four slots 12 near the distal end”); ’670 Patent col. 4:40 (“the distal end of the tube”); ’670 Patent col. 5:55 (“the distal end of the tube”). *See also* ’670 Patent col. 5:15 (“the distal tip 82 of the memory metal tube”); ’670 Patent col. 6:31–32 (referring to Fig. 11: “This

“distal end” of the expandable section.² However, every time “distal end” is used in the claims, it explicitly references the end of the metal tube. *E.g.*, ’670 Patent col. 7:21–22 (“the metal tube having . . . a distal end”); ’670 Patent col. 7:25–26 (“the distal end of the metal tube”). The claims never use “distal end” in reference to the end of the expandable section. Therefore, EVM is correct that the distal end refers to the end of the tube.

If the expandable section were always located at the end of the metal tube, the distal end could also refer to the end of the expandable section, as Defendants contend. However, that is not the case. Figures 1A and 1B disclose a tube with an expandable section bound on both sides by non-expandable sections. Further, the specification makes clear that the expandable section can be in different locations along the device. *See, e.g., id.* at col. 2:59–61 (“The slotted section can be made in several places along the length of the memory metal tube”). Even the specification excerpts Defendants cite describe the expandable section *near* the distal end, not only *at* the distal end. *E.g., id.*, Abstract (“The wall of the tube has been provided with a plurality of slots in specific places, often near or at the distal end of the instrument”). Therefore, the distal end refers to the end of the tube, which is not necessarily the end of the expandable section. Because the distal end explicitly references the end of the metal tube every time it is used in the claims, further construction is unnecessary on this point.

Second, the parties dispute the orientation of the distal end. Defendants’ proposed construction places the distal end at the “terminal end.” EVM’s proposed construction orients the distal end at the end “located furthest downstream.” Both of these constructions are flawed.

can be done by letting the zigzag slots run to the free end of the distal tip (not shown”); ’670 Patent col. 5:58–60 (“The memory metal tube 101 itself acts as a delivery tube for a third tube 107 that contains an optical system 106 that looks forward from the distal tip 109 for visual inspection”); ’670 Patent col. 6:55–57 (“the tube can exist from several segments that run through the entire length from proximal to distal.”).

² ’670 Patent col. 4:13–15 (“Two one way valves 46 and 47 above and below the balloon section and connected to its distal and proximal ends, respectively, enable a pumping action in the distal direction”).

Defendants' proposed construction is not helpful because it is unclear which end would be the "terminal end" of the expandable section. The specification discloses embodiments in which the expandable section is bound on both sides by non-slotted sections. *E.g., id.*, Figs. 1A, 1B. Defendants' briefing offers no way to differentiate one of those sides as the "terminal end" of the expandable section.

EVM's suggestion that distal end should be oriented at the end "located furthest downstream," and its associated argument that distal end should be oriented according to the position of a physician, are also flawed. EVM cites a dictionary to support its claim that "distal" generally refers to a location situated away from a point of reference. Docket No. 45 at 19. It relies on the declaration of Dr. David Schwartz to define that point of reference with respect to the distal end. *Id.* at 19–20. For embodiments that are present in a patient's body only during a procedure, EVM contends the point of reference is the physician performing the procedure. *Id.* For embodiments that remain in a patient's body after a procedure, EVM contends the point of reference is the direction of blood flow. *Id.* at 20. However, Dr. Schwartz's declaration notes that for certain devices that remain in a patient's body after a procedure, the point of reference switches from the physician during the procedure to the direction of blood flow afterwards. Docket No. 45, Ex. K at ¶¶ 23–24. Therefore, when inserted in the "upstream" direction, the distal end of these devices would switch from the upstream end during the procedure to the downstream end afterwards. Accordingly, orienting the distal end according to the position of a physician or the direction of blood flow would be incorrect.

It would also be incorrect to define distal end in relation to where the particle to be caught enters the tube. This is because the particle could enter from either the distal or proximal

end.³ A solid particle could enter from the distal end of the tube if the distal end were an unbound expandable section. The specification discloses such an embodiment. '670 Patent col. 4:39–40 (“slots 65 . . . proceed to the distal end of the tube”). In that scenario, the distal end could be in an expanded shape to allow the particle to enter the tube and then transform to a contracted shape after the particle enters. The specification describes how this could occur by making the medical instrument from “a shape memory tube with a transformation temperature that is above or below the ambient temperature.” *Id.* at col. 2:18–20.

Alternatively, a solid particle could enter from the proximal end of the tube. This must occur where the distal end is a non-expandable section. In this scenario, the proximal end would have to be large enough to allow the solid particle to enter. Claim 1 does not recite a cross-sectional dimension for the proximal end. Claim 26, when read in light of claim 27, allows for a proximal end that is larger than the distal end. *Id.*, claim 26 col. 8:57–59 (reciting the distal end is *different* from the proximal end); *id.*, claim 27 col. 8:60–62 (reciting the distal end is *larger* than the proximal end). Accordingly, the claim language is broad enough to include this scenario.

Since the claim language is clear that the distal end is opposite the proximal end and that the particle to be caught can enter either through the distal end or the proximal end, no further construction of the term “distal end” is required.

the metal members being sufficiently rigid to substantially maintain the expanded shape of the expandable section when placed within and in contact with the tubular structure of the human body

EVM originally proposed that no construction was necessary, but alternatively proposed “the metal members when expanded within and in contact with the tubular structure of the

³ The patent defines distal and proximal ends as opposite one another. *See, e.g.*, '670 Patent col. 6:55–57 (describing the length of the tube runs “from proximal to distal”); '670 Patent, claim 24 (reciting “a distal end opposite said proximal end”).

human body, are resistant to contraction from the expanded state so as to remain in contact with the tubular structure.” Defendants originally proposed “the metal members when expanded within and in contact with the tubular structure of the human body, are resistant to contraction from the expanded state by the range of forces typically exerted on the tubular structure within which the device is placed.”

The parties’ original proposed constructions are identical until their final clauses. At the hearing, the parties agreed to drop their final clauses and construe the term according to the identical portions of their original proposed constructions. The Court adopts the parties’ agreed construction and construes the term as “the metal members when expanded within and in contact with the tubular structure of the human body, are resistant to contraction from the expanded state.”

the metal tube having only a single lumen

EVM originally proposed that no construction was necessary, while Defendants originally proposed “the metal tube has only one passageway.” At the hearing, the parties agreed that a “lumen” is a longitudinal passageway. The parties’ only remaining dispute is whether slots on the sides of the metal tube, numbered 12 in Figures 1A and 1C below, qualify as longitudinal passageways.

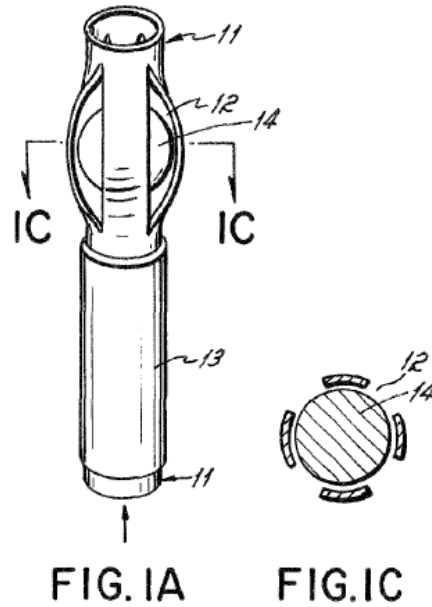

'670 Patent Figs. 1A, 1C.

The term “lumen” only appears in the '670 Patent claims and does not appear in the specification. The '670 Patent's limitation that “the metal tube ha[s] only a *single* lumen” distinguishes the claimed invention from the Ham Patent. *See* Docket No. 45-11 at 3 (October 26, 2010 Examiner Interview Summary). The Ham Patent discloses a catheter with three lumens, numbered 17, 20, and 26 in Figures 1 and 3 below. Docket No. 47-20 col. 5:19–36 (Ham Patent). These lumens extend through the interior of the catheter claimed in the Ham Patent. *Id.* The Ham Patent distinguishes these three lumens from a “longitudinal slit,” numbered 25 in Figures 1 and 3 below. *Id.* at col. 5:29. The “longitudinal slit” is preferably provided in the sidewall of the Ham Patent's catheter. *Id.*

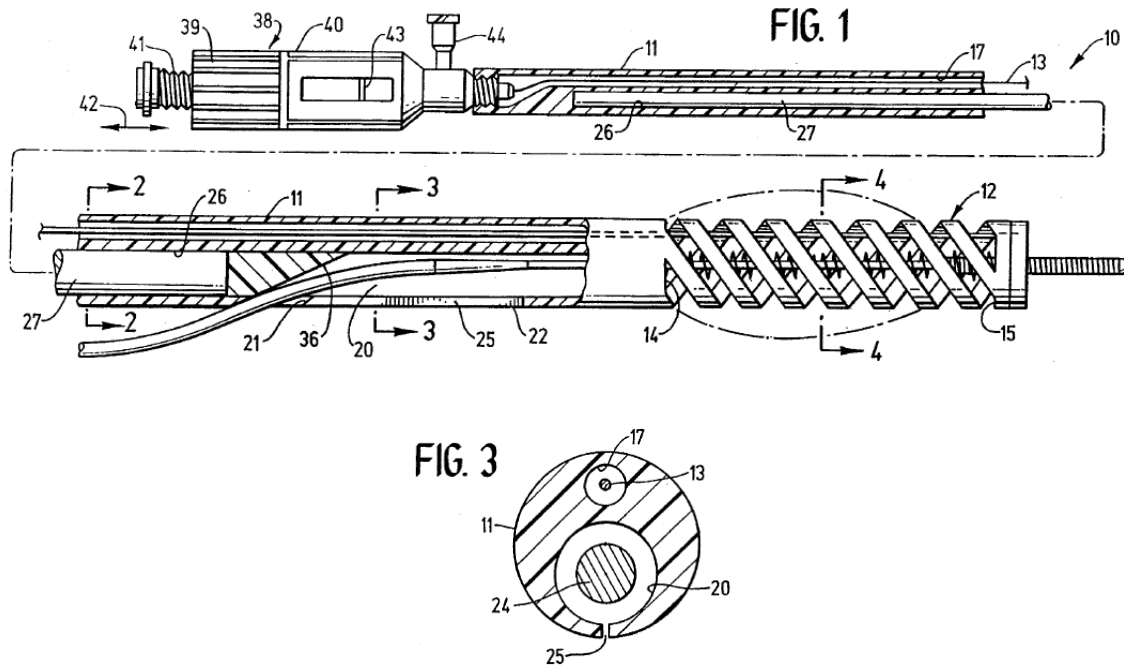

Id., Figs. 1, 3.

In light of the Ham Patent, it is clear that the '670 Patent uses the term “lumen” to refer to the longitudinal passage that extends through the interior of the metal tube, and not to the slots on the side of the metal tube. Just as the Ham Patent has three lumens that extend through the interior of the catheter, the '670 Patent has one longitudinal passage that extends through the interior of the metal tube. Because the '670 Patent claims a “metal tube having only a *single* lumen,” the slots on the sides of the metal tube cannot also be “lumens.”

Accordingly, the Court construes “lumen” as “a longitudinal passage of the tube.” In light of the Ham Patent, it is clear the term “lumen” does not include any peripheral openings, such as slots, in the wall of the tube.

CONCLUSION

For the foregoing reasons, the Court interprets the claim language in this case in the manner set forth above. For ease of reference, the Court’s claim interpretations are set forth in a table in Appendix A.

So ORDERED and SIGNED this 4th day of June, 2014.

A handwritten signature in black ink, appearing to read "Leonard Davis". The signature is written in a cursive style with a large, prominent loop for the letter "D".

**LEONARD DAVIS
UNITED STATES DISTRICT JUDGE**

APPENDIX A

Claim Term	Court's Construction
the metal tube including at least one of a memory effect and superelasticity and having at least one expandable section with a plurality of metal members separated by openings and capable of contraction and expansion to an expanded shape	No construction necessary.
a retrieval basket for retrieving particles to be removed from the human body	No construction necessary. The Court clarifies that the particle is to be removed.
the metal members being sufficiently rigid to substantially maintain the expanded shape of the expandable section when placed within and in contact with the tubular structure of the human body	the metal members when expanded within and in contact with the tubular structure of the human body, are resistant to contraction from the expanded state
the metal tube having only a single lumen	A lumen is a longitudinal passage of the tube. This does not include any peripheral openings, such as slots, in the wall of the tube.
distal end	No construction necessary. The Court clarifies that the distal end is opposite the proximal end and that the particle to be caught can enter either through the distal end or the proximal end.
the expandable section being free of interior structure that is axially movable within the expandable section to expand and/or contract the expandable section	No construction is necessary.
an outer tube that surrounds at least the expandable section of the monolithic memory metal tube and which cooperates with said memory metal tube during expansion and/or contraction thereof	No construction is necessary.
one of the openings forms a slot parallel to the central longitudinal axis of the metal tube	No construction is necessary.
openings are slots	No construction is necessary.