

**IN THE UNITED STATES DISTRICT COURT
FOR THE WESTERN DISTRICT OF TEXAS
WACO DIVISION**

DEMARAY LLC,
Plaintiff

-v-

INTEL CORPORATION,
Defendant

W-20-CV-00634-ADA

DEMARAY LLC,
Plaintiff

-v-

**SAMSUNG ELECTRONICS CO., LTD.
(A KOREAN COMPANY), SAMSUNG
ELECTRONICS AMERICA, INC.,
SAMSUNG SEMICONDUCTOR, INC.,
SAMSUNG AUSTIN
SEMICONDUCTOR, LLC,**
Defendants

W-20-CV-00636-ADA

CLAIM CONSTRUCTION ORDER AND MEMORANDUM IN SUPPORT THEREOF

Before the Court are the Parties' supplemental claim construction briefs: Defendants Intel Corporation; and Samsung Electronics Co., Ltd., Samsung Electronics America, Inc., Samsung Semiconductor, Inc., and Samsung Austin Semiconductor, LLC's Opening and Response briefs (ECF Nos. 6-20-cv-00636 313 and 322,¹ respectively) and Plaintiff Demaray's Opening and Response briefs (ECF Nos. 315 and 323, respectively). The Court provided preliminary constructions for the disputed terms one day before the hearing. The Court held the *Markman*

¹ Because Intel's and Samsung's brief are virtually identical, the Court will refer to Samsung's briefs and more generally to the *Samsung* case (6-20-cv-00636).

hearing on May 30, 2023. ECF No. 338. The Court now enters its final constructions and provides its reasoning for those constructions.

I. DESCRIPTION OF THE ASSERTED PATENTS

Plaintiff asserts U.S. Patent Nos. 7,381,657 and 7,544,276. The '657 Patent is entitled “Biased pulse DC reactive sputtering of oxide films” while the '276 Patent is entitled “Biased pulse DC reactive sputtering of oxide films.” The Asserted Patents purport to improve physical vapor deposition (“PVD”), “which is performed in a chamber having a substrate (or wafer); a metal target from which the deposited metal originates; and a plasma between the substrate and the target.” Plaintiff’s Opening at 4 (quoting Plaintiff’s Opening, Ex. 3 (February 16, 2021 Glew Declaration at ¶¶ 17–18)).

Figure 1A depicts a PVD chamber comprising five key components: radio-frequency (“RF”) bias power supply 18, substrate 16, target 12, narrow band rejection filter 15, and pulsed DC power supply 14. '276 Patent at Figure 1, '657 Patent at Figure 1.

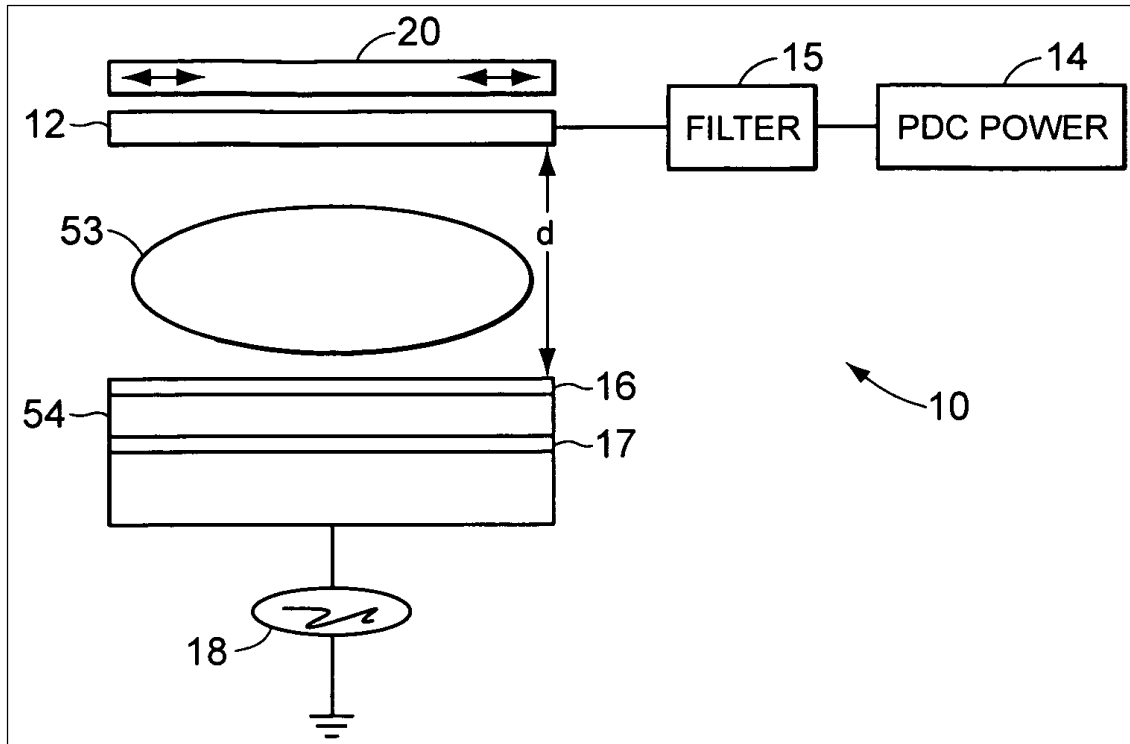

Figure 1A depicts that RF bias power supply 18 is coupled to electrode 17. '276 Patent at 5:27–28. Substrate 16 is capacitively coupled to electrode 17 through insulator 54. *Id.* at 5:26–27. Plasma 53 is created when power is applied to target 12. *Id.* at 5:25–26. Pulsed DC power supply 14 is coupled to narrow-band rejection filter 15, which is coupled to target 12. *Id.* at 5:19–20.

The specifications disclose that the RF bias power from RF bias power supply 18 may flow into pulsed DC power supply 14. *See id.* at 5:50–51. In order to prevent the RF bias power from damaging pulsed DC power supply 14, the claimed inventions use a narrow-band rejection filter (“NBRF”), *e.g.*, 2MHz with a bandwidth of 100KHz. *Id.* at 5:50–51, 5:51–54. A narrow-band rejection filter rejects RF frequencies within the filter bandwidth (100KHz), which is centered around the center frequency (2MHz). By contrast, a RF filter may filter out all RF frequencies above/below a particular threshold, not just those within a particular frequency range.

II. LEGAL STANDARD

The general rule is that claim terms are generally given their plain-and-ordinary meaning. *Phillips v. AWH Corp.*, 415 F.3d 1303, 1312 (Fed. Cir. 2005) (*en banc*); *Azure Networks, LLC v. CSR PLC*, 771 F.3d 1336, 1347 (Fed. Cir. 2014), *vacated on other grounds*, 575 U.S. 959, 959 (2015) (“There is a heavy presumption that claim terms carry their accustomed meaning in the relevant community at the relevant time.”) (internal quotation omitted). The plain-and-ordinary meaning of a term is the “meaning that the term would have to a person of ordinary skill in the art in question at the time of the invention.” *Phillips*, 415 F.3d at 1313.

The “only two exceptions to [the] general rule” that claim terms are construed according to their plain-and-ordinary meaning are when the patentee (1) acts as his/her own lexicographer or (2) disavows the full scope of the claim term either in the specification or during prosecution. *Thorner v. Sony Computer Ent. Am. LLC*, 669 F.3d 1362, 1365 (Fed. Cir. 2012). The Federal Circuit has counseled that “[t]he standards for finding lexicography and disavowal are exacting.” *Hill-Rom Servs., Inc. v. Stryker Corp.*, 755 F.3d 1367, 1371 (Fed. Cir. 2014). To act as his/her own lexicographer, the patentee must “clearly set forth a definition of the disputed claim term” and “‘clearly express an intent’ to [define] the term.” *Thorner*, 669 F.3d at 1365.

“Like the specification, the prosecution history provides evidence of how the PTO and the inventor understood the patent.” *Phillips*, 415 F.3d at 1317. “[D]istinguishing the claimed invention over the prior art, an applicant is indicating what a claim does not cover.” *Spectrum Int’l, Inc. v. Sterilite Corp.*, 164 F.3d 1372, 1379 (Fed. Cir. 1998). The doctrine of prosecution disclaimer precludes a patentee from recapturing a specific meaning that was previously disclaimed during prosecution. *Omega Eng’g, Inc. v. Raytek Corp.*, 334 F.3d 1314, 1323 (Fed. Cir. 2003). “[F]or prosecution disclaimer to attach, our precedent requires that the alleged

disavowing actions or statements made during prosecution be both clear and unmistakable.” *Id.* at 1325–26. Accordingly, when “an applicant’s statements are amenable to multiple reasonable interpretations, they cannot be deemed clear and unmistakable.” *3M Innovative Props. Co. v. Tredegar Corp.*, 725 F.3d 1315, 1326 (Fed. Cir. 2013).

III. LEGAL ANALYSIS

The parties dispute the constructions for the “coupled to” and the “providing” terms in the below table.

Term	Plaintiff’s Proposed Construction	Defendants’ Proposed Construction
“coupled to the substrate” / “coupled to ... the substrate” U.S. Patent No. 7,381,657, Claims 1 and 6	Plain-and-ordinary meaning	“coupled to the substrate, such that the pulsed DC power source and the RF bias power are coupled to different components (target and substrate respectively)”
“providing...to the substrate” U.S. Patent No. 7,544,276, Claims 1 and 2	Plain-and-ordinary meaning	“providing ... to the substrate, such that the pulsed DC power source and the RF bias power are coupled to different components (target and substrate respectively)”

Background:

The Court previously had *Markman* hearings on August 17, 2021 and February 28, 2022 to construe terms in this case. ECF Nos. 119 and 172, respectively. Defendants moved for further construction based on alleged disclaimers Plaintiff made during IPR proceedings.² ECF No 263

² Much of Plaintiff’s Opening Brief—and Defendants’ response to Plaintiff’s arguments—is directed towards arguments unrelated to prosecution disclaimer. Because the Court finds that the claim construction of the disputed terms depends on the whether Plaintiff “clearly and unambiguously” disclaimed claim scope, the Court, in the interest of brevity, does not summarize and/or address those arguments.

(Motion for Further Claim Construction) at 1. More specifically, Defendants allege that Plaintiff argued that the claimed invention involves “RF bias and pulsed DC power supplies connected to *different* components that are *remote* from one another” in order to distinguish prior art references. *Id.* (emphasis in Defendants’ brief).

Defendants’ arguments:

Defendants contend that during IPR proceedings in connection with the related patents, Plaintiff “repeatedly represented to the PTAB that its claimed invention differs from the prior art because—unlike prior-art references disclosing an ‘RF power supply 16 and [] DC power 30 [that] are both connected to the *same* component—the ‘configuration that is at issue in the claims’ has an RF power supply that is connected to a different component that is ‘*remote from*’ the pulsed DC power supply. Defendants’ Opening at 13 (quoting Ex. 20 (IPR Hr’g Tr.) at 76:7–15, 77:5–7; citing Ex. 7 (’276 Patent Patent Owner’s Response) at 59; Ex. 11 (’276 Patent Glew Declaration) at ¶¶ 114, 137, 175; Ex. 5 (’276 Patent Patent Owner’s Preliminary Response) at 40–41; Ex. 9 (’276 Patent Patent Owner’s Sur-Reply) at 19–20) (emphasis in Defendants’ brief). Defendants contend that “[i]n advancing this argument, [Plaintiff] successfully persuaded the PTAB that its claimed invention was non-obvious because—unlike the prior art—it included the narrow-band rejection filter to protect the pulsed DC power supply from a *remote* RF bias power supply.” *Id.* at 13–14 (emphasis in Defendants’ brief).

Barber prior art reference (U.S. Patent No. 6,342,134): Defendants contend that the Barber prior art reference “describes a PVD chamber with a pulsed DC power supply connected to a target and an RF bias power supply connected to the substrate.” *Id.* at 3. More specifically,

Defendants contend that Figure 2 in the Barber prior art reference depicts pulsed DC power supply 230 coupled to target 260 and RF bias power supply connected to coupled to substrate 110. *Id.*

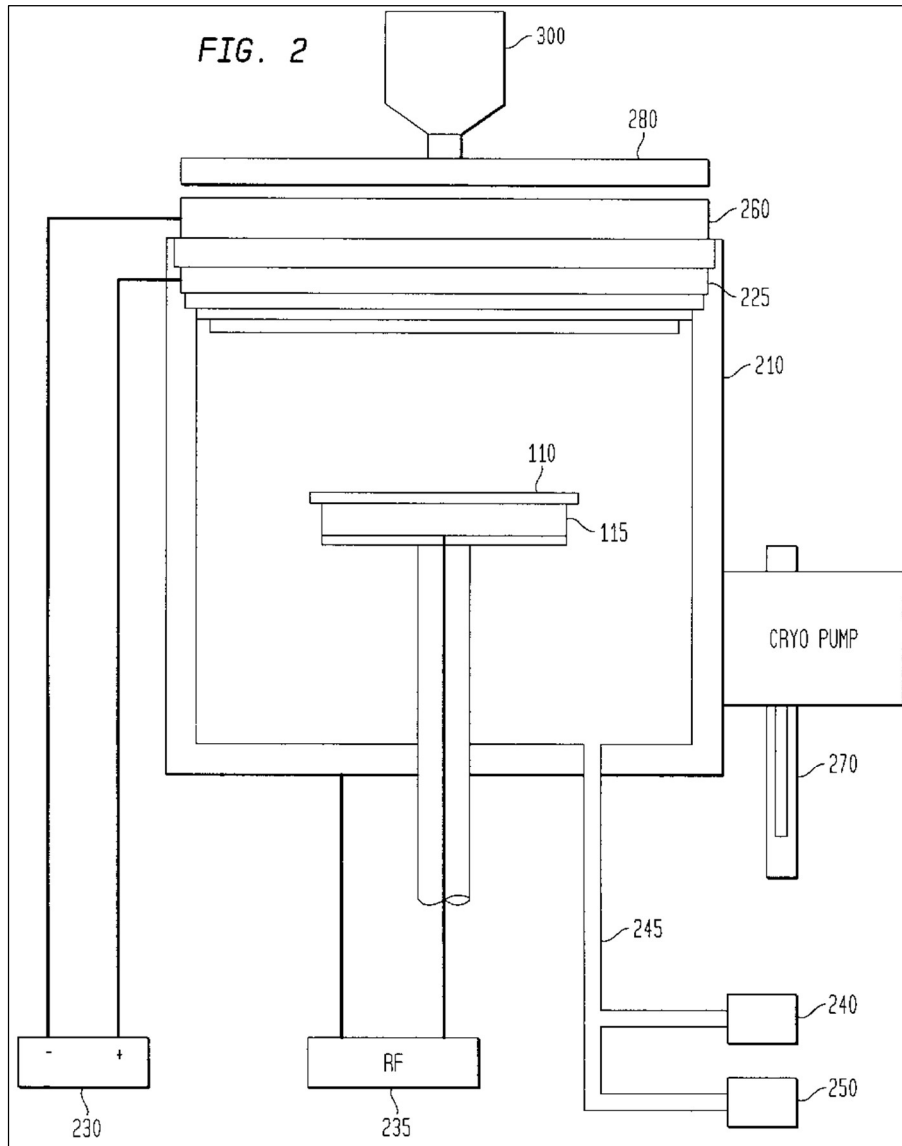

Defendants contend that “RF filters were already widely known and, in fact, were commonly used to protect DC power supplies from RF power supplies in PVD chambers.” *Id.* Defendants contend that according to Plaintiff, the “purported point of novelty in its patents was the use of a narrow-band rejection filter to protect a pulsed DC power supply from a *remotely coupled* RF bias power supply.” *Id.* at 3–4 (quoting Defendant’s Opening, Ex. 7 (’276 Patent

Patent Patent Owner's Response) at 59) (emphasis in Defendants' brief). Based on that, Defendants contend that Plaintiff argued that

[A]lthough it might have been obvious to include an RF filter to protect a DC power supply from an RF power supply that were connected to the *same* chamber component, it would not have been obvious to use an RF filter in the *claimed* chamber configuration, where the two power supplies were coupled to *different* chamber components, *remote* from one another.

To advance this argument, [Plaintiff] was forced to disclaim chambers where the two power supplies were connected to the *same* component. In other words, throughout the IPR proceedings, [Plaintiff] repeatedly characterized the scope of its claims as *requiring* that the two claimed power supplies—the pulsed DC power supply and the RF bias power supply—be connected to *different* components (the target and the substrate) that are *remote* from one another. In doing so, [Plaintiff] distinguished configurations where both power supplies were connected to the *same* chamber component.

Id. at 4 (quoting Opening, Ex. 7 ('276 Patent Patent Owner's Response) at 59) (emphasis in Defendants' brief).

Hong prior art reference (U.S. Patent No. 6,695,954). Defendants contend that the left side of Figure 1 in Hong depicts that bipolar DC power supply 24 and RF bias power supply 26 are connected to target 4 and substrate 14, respectively. *Id.* at 5. But Defendants note “*no* RF filter ... protect[s] bipolar DC power supply 24 from remotely coupled RF bias power supply 26.” *Id.* (emphasis in Defendants' brief). Defendants contend that the right side of Figure 1 in Hong depicts that RF power supply 16 and DC voltage source 30 are both connected to the same component, coil 6, and that, unlike the left side, filter 32 protects DC power supply 30 from the co-coupled RF power supply 16. *Id.* at 6.

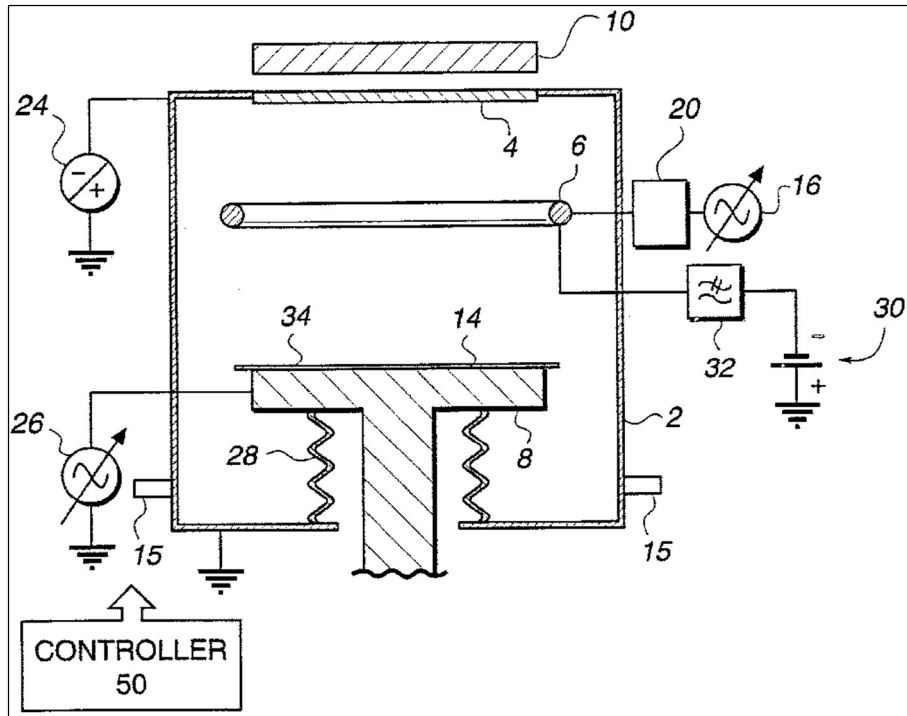

Defendants contend that during the IPRs, Plaintiff “repeatedly” distinguished Hong. *Id.* For example, Defendants contend that Plaintiff argued that the right-hand side of Figure 1 in Hong depicts that “coil 6 is connected to *both* the RF power *and* the DC power 30. *Id.* (emphasis in Defendants’ brief). This *differs from the challenged claims*, where a bipolar pulsed DC power source is ‘coupled to the target/target area’ and the RF power source is ‘coupled to the *substrate.*’” *Id.* (quoting Defendants’ Opening, Ex. 5 (’276 Patent Patent Owner’s Preliminary Response) at 40, Ex. 6 (’657 Patent Patent Owner’s Preliminary Response) at 40) (emphasis in Defendants’ brief)). Defendants contend that Plaintiff then “expressly stated that ‘the *claimed system*’ requires that the ‘pulsed DC power source and RF power are coupled to *different components (target and substrate respectively).*’” *Id.* (quoting Defendants’ Opening, Ex. 5 (’276 Patent Patent Owner’s Preliminary Response) at 41, Ex. 6 (’657 Patent Patent Owner’s Preliminary Response) at 41) (emphasis in Defendants’ brief)); *see also id* at 9.

Defendants contend that Plaintiff's expert (Dr. Alexander Glew) distinguished the Hong prior art reference by opining that while Hong disclosed that "coil 6 is connected to both the RF power and the DC power 30," the claimed invention discloses that the two different types of power sources—RF bias power supply 18 and pulsed DC power supply 14—are connected to two different components, *i.e.*, to substrate 18 and target 12, respectively. *Id.* at 7 (quoting Defendants' Opening, Ex 11 ('276 Patent Glew declaration) at ¶ 151, Ex, 12 ('657 Patent Glew declaration) at ¶ 151). Defendants contend that Plaintiff's expert further explained that "POSITAs neither knew nor found it desirable to couple a claimed narrow band-rejection filter to a pulsed DC power source to reject a *remote* RF power source (*i.e., RF power source applied to a different component than the DC power source*)." *Id.* (quoting Defendants' Opening, Ex 11 ('276 Patent Glew declaration) at ¶ 175, Ex, 12 ('657 Patent Glew declaration) at ¶ 175) (emphasis in Defendants' brief); *see also id* at 14.

Sproul prior art reference (U.S. Patent No. 5,942,089): Defendants contend that Plaintiff's expert opined that the Sproul prior art reference disclosed that bipolar pulsed DC power supply 32 is connected to the target and RF bias power supply 50 is connected to the substrate. *Id.* at 7.

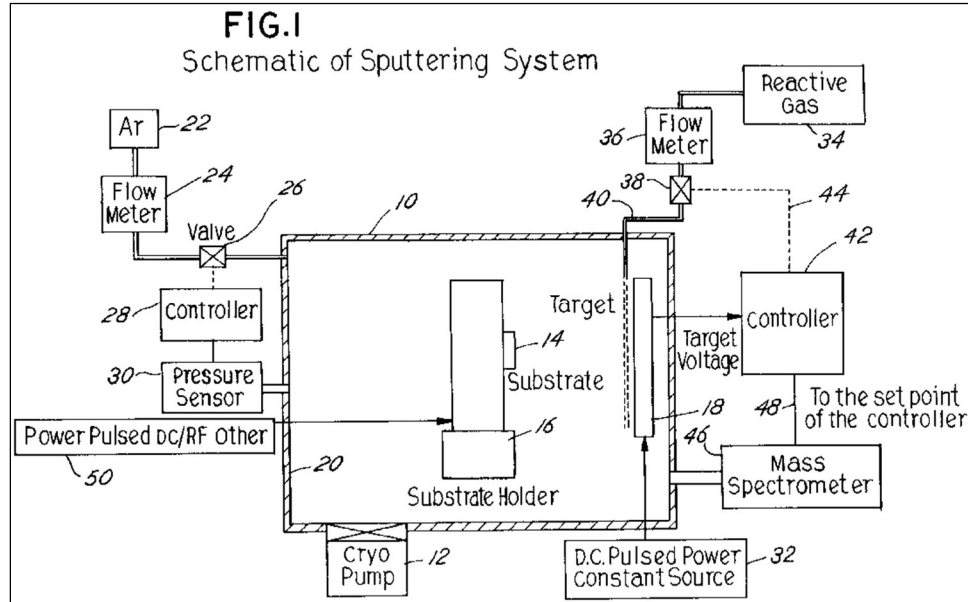

Defendants contend that Sproul also disclosed a RF filter. *Id.* Defendants contend that Plaintiff's expert opined that Sproul disclosed that the "induced DC and RF both operate on the substrate that they may be viewed as *directly connected to each other.*" *Id.* at 7–8 (quoting Defendants' Opening, Ex 11 ('276 Patent Glew declaration) at ¶ 129, Ex, 12 ('657 Patent Glew declaration) at ¶ 129) (emphasis in Defendants' brief). Defendants contend that Plaintiff's expert opined that when two power supplies are directly connected, "a strong coupling effect would be expected and the use of a filter would be appropriate for address[ing] such a strong coupling." *Id.* (quoting Defendants' Opening, Ex 11 ('276 Patent Glew declaration) at ¶ 129, Ex, 12 ('657 Patent Glew declaration) at ¶ 129). Defendants contend that Plaintiff's expert opined that "RF power source 50 and bipolar pulsed DC power source 32 ... are not directly connected to each other, but are spaced apart. Sproul does not disclose or suggest that a filter would be needed to address the potential coupling of RF power source 50 in *the remote power source 32.*" *Id.* at 8 (quoting Defendants' Opening, Ex 11 ('276 Patent Glew declaration) at ¶¶ 130, 175, n.6, Ex, 12 ('657 Patent Glew declaration) at ¶¶ 130, 175, n.6) (emphasis in Defendants' brief); *see also id.* at 14.

Celestino prior art reference (U.S. Patent No. 4,579,618): Defendants contend that Plaintiff's expert opined that the Celestino prior art reference disclosed a "notch filter to protect one RF power supply from another RF power supply." *Id.* at 8 (citing '618 Patent (Celestino) at 3:53–63, 4:20–27).

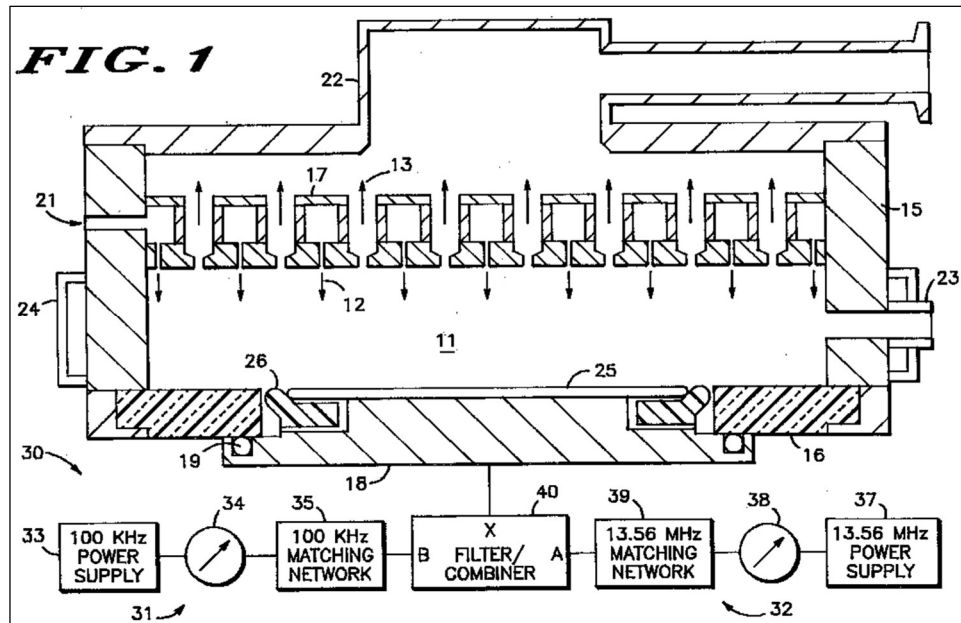

Defendants contend that Plaintiff's expert opined that Celestino disclosed "two separate power sources both connected to the *same* component," explaining that "Celestino's power supply structure 30 is coupled to electrode 18 and includes *both* a 100 kHz low-frequency RF power source 31 *and* a 13.56MHz high-frequency RF power source 37." *Id.* (quoting Defendants' Opening, Ex 11 ('276 Patent Glew declaration) at ¶ 141, Ex. 12 ('657 Patent Glew declaration) at ¶ 141) (emphasis in Defendants' brief). Defendants contend that Plaintiff's expert opined that Celestino was "*so different* from the claimed [invention]" which had "*two remote power sources.*" *Id.* at 14 (quoting Defendants' Opening, Ex 11 ('276 Patent Glew declaration) at ¶¶ 143–144; Ex. 12 ('657 Patent Glew declaration) at ¶¶ 143–144) (emphasis in Defendants' brief).

Prior art power supply manuals: Defendants contend that the manuals disclosed "using an RF filter to protect a DC-based power source when also using an RF power source). *Id.* at 8

(citing Defendants’ Opening, Ex. 3 (’276 Patent IPR Petition) at 34–35, Ex. 4 (’657 Patent IPR Petition) at 26–27). Defendants contend that Plaintiff’s expert opined that:

[A] person of ordinary skill in the art would interpret “[d]o not apply RF power directly to the output of the Pinnacle [Pinnacle Plus] unit” as referring to connecting RF power source and Pinnacle Plus with a direct connection, such as the configuration in [IPR exhibit] 1014. As I have stated above, the use of a filter in such configurations [is] not surprising, but that does not suggest the use of a filter ***in the claimed manner of the ’276 Patent, i.e., to use the filter to block the RF power from a remote power source.***

Id. at 8 (quoting Defendants’ Opening, Ex 11 (’276 Patent Glew declaration) at ¶ 167; Ex, 12 (’657 Patent Glew declaration) at ¶ 167) (emphasis in Defendants’ brief); *see also id.* at 15.

Defendants contend that Plaintiff, relying on its expert’s opinion, argued that “at the time of invention, POSITAs neither knew nor found it desirable to couple a claimed narrow band-rejection filter to a pushed DC power source to block RF energy or current from a ***remote*** RF power source (i.e., ***RF power source applied to a different component than the DC power source.***” *Id.* at 8–9 (quoting Defendants’ Opening, Ex. 7 (’276 Patent Patent Owner’s Response) at 59; Ex. 8 (’657 Patent Patent Owner’s Response) at 57) (emphasis in Defendants’ brief). Defendants contend that Plaintiff later similarly argued that “no prior art ever taught using an NBRF [narrow band-rejection filter] in series with a pulsed DC (or DC) power source to block out a ***remote*** RF power source.” *Id.* at 9 (quoting Defendants’ Opening, Ex. 9 (’276 Patent Sur-Reply) at 19; Ex. 10 (’657 Patent Sur-Reply) at 19) (emphasis in Defendants’ brief).

Defendants contend that the PTAB relied on Plaintiff’s arguments that “its claims require the two power supplies to be coupled to ***different*** components, remote from one another, and found “that a POSITA would not have been motivated to provide a filter to protect a DC power source from a ***remote*** RF power source.”” *Id.* at 10 (quoting Defendants’ Opening, Ex. 22 (’276 Patent Final Written Decision) at 51–61, Ex. 23 (’657 Patent Final Written Decision) at 38–40) (emphasis

in Defendants' brief). Defendants contend that the PTAB "further credited [Plaintiff's expert's] testimony that 'the fact that a filter is needed to decouple *two directly connected power source[s]* says nothing about whether decoupling *two remote power sources* (even if one is an RF power source) would be beneficial.'" *Id.* at 10 (citing Defendants' Opening, Ex. 22 ('276 Patent Final Written Decision) at 38, Ex. 23 ('657 Patent Final Written Decision) at 27) (emphasis in Defendants' brief). Defendants contend that the PTAB also relied on Plaintiff's expert's testimony regarding the Sproul, Celestino, and the power supply manuals prior art references. *Id.*

Defendants contend that throughout the IPRs, Plaintiff "clearly and unambiguously conveyed to the public that its claims are limited to configurations where the pulsed DC power supply and the RF bias power supply are coupled to *different* chamber components that are *remote* from one another, and do not encompass reactors where the two claimed power supplies are both connected to the *same* component." *Id.* at 15 (citing IPR documents) (emphasis in Defendants' brief). Despite Plaintiff's repeated disclaimers, Defendants contend that Plaintiff now improperly "accuses chambers where a continuous DC power supply and an RF generator are connected to the *same component* (*i.e.*, the target), not different components that are remote from one another." *Id.* at 16 (emphasis in Defendants' brief).

Defendants contend that Plaintiff "seeks to recast its distinctions of the prior-art references during the IPRs." Defendants' Opening at 17. With respect to the Hong prior art reference, Defendants contend that Plaintiff "did not limit its distinction for Hong to the coil," rather Plaintiff's exact language was "connected to the *same component*." *Id.* (citing Ex. 5 ('276 Patent Patent Owner's Preliminary Response) at 41; Ex. 6 ('657 Patent Patent Owner's Preliminary Response) at 41) (emphasis in Defendants' brief). With respect to the Celestino prior art reference, Defendants contend that Plaintiff "post-hoc focuses on other distinctions," but that does not change

the fact that Plaintiff made the alleged disclaimers and the PTAB relied on those alleged disclaimers. *Id.* at 17–18 (citing IPR documents).

Finally, although the claim language of the '657 Patent and '276 Patent use different language (“coupled to the substrate” and “providing ... to the substrate,” respectively), Defendants contend that because Plaintiff made “precisely the same arguments to the PTAB when defending the '657 Patent as it did when defending the '276 Patent[,]” all of Plaintiff’s “IPR disclaimers and interpretations of claim scope regarding the '276 Patent, therefore, apply equally to the '657 Patent’s ‘providing...to substrate’ claim elements.” *Id.* Defendants contend that a common construction is “proper” given that the two patents share a common specification. *Id.* (citing *Ormco Corp. Align Tech., Inc.*, 498 F.3d 1307, 1314 (Fed. Cir. 2007)).

Plaintiff’s arguments:

In its Opening, with respect to the Barber prior art reference, Plaintiff contends that, in response to the IPR petitioner’s argument that Barber disclosed that there was “RF bias coupling between the target and the substrate,” the “coupling” was sufficiently small that using the claimed NBRF would not have been beneficial. Plaintiff’s Opening at 14–15. In other words, Plaintiff contends that “there is an insufficient amount of RF bias power coupled to the target in Barber to warrant the use of a NBRF.” *Id.* at 15. Plaintiff contends that this argument is in accord with the specification’s teachings that the NRBF is used to prevent damaging RF bias power from the target from coupling into the DC power supply. *Id.* As such, Plaintiff contends that it never disavowed systems where RF bias power is coupled to the target. *Id.*

Plaintiff contends that its IPR arguments focused on whether the combined prior art references disclosed a NBRF, not whether the RF bias was “remote.” *Id.* More specifically,

Plaintiff contends that it argued that, rather than using an NBRF, the prior art references instead disclosed a filter “between the pulsed DC power supply and the target area” and the filter in one of the prior art references did not reject frequencies at the frequency of the RF bias power supply as required by the claims. *Id.* at 15–16 (citing Ex. 5 (’276 Patent Patent Owner’s Preliminary Response) at 41). Plaintiff contends that it—consistent with the teachings of the specification—never disavowed systems where RF bias power is coupled to the target. *Id.*

Plaintiff contends that the statements identified by Defendants:

[G]enerally explained one or more of the following: (a) why the prior art is lacking an NBRF; (b) why the prior art failed to teach the use of an NBRF; (c) how the prior art is missing one or more other elements of the Demaray Patents (such as a DC power supply or target); (d) how the prior art includes additional elements (such as a coil) not present in the Demaray Patents,; and even (e) how two power supplies are not “directly” coupled if a filter resides between them

Id. at 17 (internal citations omitted). Plaintiff contends that these statements do not constitute “clear and unmistakable” disclaimers, let alone a disavowal of an RF bias power supply coupled to both the substrate and the target.. *Id.*

Plaintiff contends that because the prosecution history “‘often lacks the clarity of the specification and thus is less useful for claim construction purposes,’ the patent specifications’ clear teachings and claims should control.” *Id.* (citing *Phillips*, 415 F.3d at 1317). Furthermore, Plaintiff contends that “the Court should reject any addition to the claims newly requiring that the RF bias power supply be coupled to the substrate and not coupled to the target,” as it would improperly exclude disclosed embodiments, which is “rarely, if ever, correct.” *Id.* (quoting *BO Lab’ys, Inc. v. Becton, Dickinson & Co.*, 474 F.3d 1323, 1333 (Fed. Cir. 2007)).

With respect to the ’657 Patent, Plaintiff contends that Defendants’ proposed construction improperly attempts to import limitations from the ’276 Patent into the ’657 Patent as “there must be a *textual reference in the actual language of the claim with which to associate a proffered*

claim construction.” *Id.* at 18 (quoting *NTP, Inc. v. Rsch. In Motion, Ltd.*, 418 F.3d 1282, 1310 (Fed. Cir. 2005) (emphasis in Plaintiff’s brief)). Plaintiff contends that the ’657 Patent claims “do not contain a textual reference for the word ‘coupled.’” *Id.* Plaintiff contends that the claims do not specify “the source of the claim element which is being provided,” *e.g.*, none of the claim limitations “specify what sources provide the ‘pulsed DC power’ or the ‘RF bias’ (or for that matter, the ‘process gas’ or the ‘magnetic field’).” *Id.* at 18–19.

Plaintiff contends that the claims are “agnostic as to the pathway the RF bias power takes to reach its destination at the substrate.” *Id.* at 19. Plaintiff contends that “[w]hile the claims do specify that the pulsed DC power must travel ‘through a narrow band rejection filter’ to reach its destination at the target, this limitation does not contain a textual reference that would permit rewriting of the claims as Defendants propose to require a ‘coupled’ pulsed DC power source or ‘coupled’ RF bias power.” *Id.* at 19.

In its Response, Plaintiff contends that “there are *not* ‘words or expressions of *manifest exclusion or restriction*, representing a *clear disavowal* of claim scope’ here supporting the addition of limitations.” Plaintiff’s Response at 2 (quoting *Teleflex, Inc. v. Ficosa N. Am. Corp.*, 299 F.3d 1313, 1327 (Fed. Cir. 2002)) (emphasis in Plaintiff’s brief). Plaintiff further contends that if the “challenged statements from the IPRs are ambiguous or amenable to multiple reasonable interpretations, prosecution disclaimer is *not* established.” *Id.* (citing *Avid Tech., Inc. v. Harmonic, Inc.*, 812 F.3d 1040, 1045 (Fed. Cir. 2016)) (emphasis in Plaintiff’s brief). Plaintiff contends that “in their actual context (from which Defendants endeavor to remove them), the cited statements do not disclaim the configurations at issue; they instead address specific prior art and specific arguments regarding such prior art put forth in the Defendants’ failed IPRs.” *Id.* at 3.

Plaintiff contends that its arguments in the IPR addressed the absence of a NBRF in the prior art references. *Id.* at 5. For example, Plaintiff contends that, in its Patent Owner’s Response for the ’276 Patent, there was “*no reference* to an RF bias power supply that does not couple to the target or that is ‘remote from’ a pulsed DC power supply. Instead, the statement made clear that [Plaintiff’s] responses to the IPRs focused on the absence of NBRF in the prior art.” *Id.* (citing Defendants’ Opening, Ex. 7 (’276 Patent Patent Owner’s Response) at 59–60) (emphasis in Plaintiff’s brief). As a second example, Plaintiff contends that its arguments regarding the Barber prior art reference “focused on the absence of an NBRF, *not* the relative locations of the pulsed DC power supply and the RF power supply[.]” *Id.* (citing Defendants’ Opening, Ex. 7 (’276 Patent Patent Owner’s Response) at 45 (“Because none of Barber, Belkind or Hirose discloses a filter “coupled between the pulsed DC power supply and the target area” as required by the challenged claims, the combination does not disclose such a filter either.”)) (emphasis in Plaintiff’s brief). As such, Plaintiff contends that “there was no reason why [Plaintiff] would distinguish Barber based on the relative locations of the pulsed DC power supply and the RF power supply.” *Id.* at 6.

With respect to Defendants’ argument that RF filters were already widely known, Plaintiff contends that a RF filter is not necessarily a NBRF because the former includes filters that are not NBRFs. *Id.* at 6.

Plaintiff contends that it:

argued consistently throughout the IPRs that prior art references either (a) did *not* disclose an NBRF, *see, e.g.*, Defendants’ Opening, Ex. 7 (’276 Patent Patent Owner’s Response) at 44 (“[t]he combination does *not* disclose a filter [] ‘coupled between the pulsed DC power supply and the target area’”) (discussing a combination including Barber), or (b) that a POSITA would *not* have found it obvious to add a NBRF to a system, *see, e.g., id.* at 49 (“A POSITA Would *Not* Have Included The Claimed Filter In Barber’s System”).

Id. (emphasis in Plaintiff's brief). With respect to the former point, Plaintiff contends that its expert opined that "while the prior art disclosed the use of filters to block RF energy, a key insight of the inventors was the use of a NBRF in particular[.]" *Id.* at 6–7 (quoting Defendants' Opening, Ex. ('276 Patent Glew Declaration) at ¶ 109). Plaintiff contends that Defendant does not contend that the prior art discloses an NBRF. *Id.* at 7.

Hong prior art reference: Plaintiff contends that while the Hong prior art reference "involves power sources connected to a coil in order to generate a plasma within the chamber," the Asserted Patents "do not describe or require such a coil, and there are no claim limitations related thereto." *Id.* at 8. Plaintiff further contends that while the Hong prior art reference had a RF blocking filter, it did not disclose a NBRF and/or "why [] a [RF] filter would be useful for applications not having a coil." *Id.*

With respect to the following statement which Defendants contend is a disclaimer, Plaintiff contends that Defendants "cherry pick" words from it and do not provide the actual context. *Id.* at 9. The statement-in-question recites "In the design below, the coil [6] is connected to both the RF power 16 and the DC power 30...This differs from the challenged claims, where a...pulsed DC power source is 'coupled to the target/target area' and the RF power source is 'coupled to the substrate.'" *Id.* (quoting Defendants' Opening, Ex. 5 ('276 Patent Patent Owner's Preliminary Response) at 40). Plaintiff agrees that this statement is correct in that the Asserted Patents "do not require anything akin to the coil 6." *Id.* Plaintiff contends that nothing in Hong discloses that "the RF power supply 16 couples, directly or indirectly, to the substrate 34, while the patent claims being challenged required that the RF power source be 'coupled to the substrate.'" *Id.*

Plaintiff contends that Defendants also cherry pick a few words from another statement. *Id.* at 10. This statement-in-question recites:

Petitioner does not explain why a filter that blocks RF transmission of the RF power connected to the same component (*e.g., coil 6*) as the DC power source to which the filter is connected would have taught or suggested a claimed filter in the claimed system where the bipolar pulsed DC power source and RF power are coupled to different components (target and substrate respectively).

Id. (quoting Defendants' Opening, Ex. 6 ('657 Patent Patent Owner's Preliminary Response) at 41) (emphasis in Plaintiff's brief). Plaintiff again contends that the Asserted Patents "do *not* disclose or claim a coil." *Id.* (emphasis in Plaintiff's brief). Furthermore, Plaintiff contends that the sentence preceding the above passage describes that nothing in Hong "suggests that the RF blocking filter is a *claimed narrow band rejection*, as opposed to a low-pass (high-frequency rejection) *filter*." *Id.* (quoting Defendants' Opening, Ex. 6 ('657 Patent Patent Owner's Preliminary Response) at 41) (emphasis in Plaintiff's brief).

Plaintiff contends that the IPR statements explaining why a reference does not disclose a NBRF "does not justify importing 21 new words, none of which concern an NBRF, into a claim without any textual basis for that matter." *Id.* Rather, Plaintiff contends that the "plain language of the claims at issue already expressly requires an NBRF and coupling of an RF power supply to the substrate." *Id.*

Celestino prior art reference: Plaintiff contends that Defendants take statements from its expert regarding the Celestino prior art reference out of context. *Id.* at 11. Plaintiff contends that there was no discussion by its expert "of a DC power source in Celestino because *power supply structure 30 contains no DC power source*" and that Celestino "*does not include a target*." *Id.* (citing Defendants' Opening, Ex. 11 ('276 Patent Glew Declaration) at ¶ 141, Ex. 12 ('657 Patent Glew Declaration) at ¶ 141) (emphasis in Plaintiff's brief). Plaintiff contends that its expert opined that the filter in Celestino does not protect a pulsed DC power supply because Celestino does not use a DC power supply. *Id.*

Plaintiff contends that “Celestino treats *power supply structure 30* as a single power supply comprising two directly connected RF power supplies located in the same ‘power supply structure 30.’” *Id.* at 12 (emphasis in Plaintiff’s brief). Plaintiff contends that the Asserted Patents disclose that “the pulsed DC power supply and the RF power supply are separate power supplies, unlike the combined RF signal from the *power supply structure 30* in Celestino.” *Id.* at 12 (emphasis in Plaintiff’s brief). Plaintiff contends that these statements are “*not* clear and unmistakable disclaimers requiring an RF power source coupled ‘remote from’ the target.” *Id.*

Sproul prior art reference: Plaintiff contends that its expert opined that the filter in Sproul does not protect the DC power supply, but rather a meter, and that it was not located between the pulsed DC power source and target. *Id.* at 13 (citing Defendants’ Opening, Ex. 11 (‘276 Patent Glew Declaration) at ¶ 128). Plaintiff contends that its focus was on the lack of disclosure of a NBRF in Sproul, and not a disavowal requiring an RF power source coupled “remote from” the target. *Id.*

Power supply manuals prior art reference: Plaintiff contends that these manuals lack a NBRF, which is not a disavowal requiring an RF power source coupled “remote from” the target. *Id.* at 13–14. Rather, Plaintiff contends that its statements were “entirely consistent with [its expert’s] testimony ... that the insight of the [Asserted Patents] was the addition of a NBRF,” and not based on the relative locations of the pulsed DC power supply and the RF power supply. *Id.* at 14.

The Court’s Analysis:

After reviewing the parties’ arguments and considering the applicable law, the Court agrees with Plaintiff that this term should be construed according to its plain-and-ordinary meaning for

the reasons that follow. **First**, the “heavy presumption” is that terms should be construed according to their plain-and-ordinary meaning. *Azure Networks*, 771 F.3d at 1347. **Second**, Defendant does not expressly allege lexicography, which is one of the two exceptions to the general rule that a term should be construed as having its plain-and-ordinary meaning. *Thorner*, 669 F.3d at 1365.

Third, the Court concludes that the alleged disclaimer does not necessarily make technical sense in light of the specification’s description that filter 15 protects pulsed DC power supply 14 from RF bias power from RF power supply 18. ’276 Patent at 5:55–56 (“Filter 15 prevents the bias power from power supply 18 from coupling into pulsed DC power supply 14.”). Based on that disclosure, a POSITA would understand that pulsed DC power supply 14 and RF power supply 18 are electrically connected (via electrode 17 (’276 Patent at 5:28–29), which is capacitively coupled to substrate 16 (’276 Patent at 5:28–29), which is electrically connected to target 12 through plasma 53 (*see, e.g.*, ’276 Patent at 5:50–51, 5:57–59), which electrically connected to pulsed DC power supply 14 (’276 Patent at 5:19–20). In other words, RF bias supply 18 is electrically connected to both target 12 and substrate 16, while pulsed DC power source 14 is electrically connected to at least target 12. As such, the requirement in Defendants’ proposed construction that the “pulsed DC power source [14] and the RF bias power [18] are coupled to different components (target [12] and substrate [16] respectively)” contradicts the teaching of the specification that RF bias power supply 18 is connected to both substrate 16 and target 12. As such, the Court concludes that the meaning of the statement is ambiguous enough that it does not meet the threshold of a “clear and unmistakable” disclaimer. *Omega Eng’g*, 334 F.3d 1314, 1325–26 (“[F]or prosecution disclaimer to attach, our precedent requires that the alleged disavowing actions or statements made during prosecution be both clear and unmistakable.”).

Fourth, the Court concludes that Plaintiff's (and Plaintiff's expert's) statements with respect to each prior art reference do not meet the high bar required for disavowal. *Hill-Rom Servs.*, 755 F.3d at 1371 (“The standards for finding lexicography and disavowal are exacting.”).

With respect to the Barber prior art reference, the Court concludes that Plaintiff did not make a disclaimer. More specifically, Barber does not disclose a RF filter—let alone a NBRF—nor does Defendants point to any RF filter in Barber. Defendants' Opening, Ex. 9 ('276 Patent Patent Owner's Sur-Reply) at 25. Furthermore, the amount of RF bias coupling between the target and the substrate” is sufficiently small that using the claimed NBRF would not have been beneficial. Therefore, the Court concludes that Plaintiff never disavowed systems where RF bias power is coupled to the target.

With respect to the Hong prior art reference, the Court concludes that Plaintiff did not make a disclaimer. The Court concludes that Plaintiff may have been describing that RF power source and DC power were connected to completely different components (*i.e.*, coil 6 in Hong and target/target area and substrate, respectively in the Asserted Patents), and not necessarily that the Hong was distinguishable because RF power source and DC power were both connected to the same component in Hong (*i.e.*, coil 6) and to different components in the Asserted Patents (*i.e.*, pulsed DC power source is coupled to the target/target area and the RF power source is coupled to the substrate). In any case, because Plaintiff's IPR statements “are amenable to multiple reasonable interpretations, they cannot be deemed clear and unmistakable.” *3M Innovative Props.*, 725 F.3d at 1326.

With respect to the Celestino prior art reference, the Court concludes that Plaintiff did not make a disclaimer. Celestino does not disclose a DC power source (but rather that it discloses two RF power supplies that are combined together into a single power supply) or a target. Therefore,

Plaintiff's IPR statements are not a clear and unmistakable disclaimer that requires that the RF power source and the non-existent DC power source be coupled to the substrate and the non-existent target, respectively.

With respect to the Sproul prior art reference, the Court concludes that Plaintiff did not make a disclaimer. More specifically, the focus of Plaintiff's expert opinions appears to be directed towards a lack of a NBRF, and the relative locations of the pulsed DC power supply and the RF power supply. For example, Plaintiff's expert opines that "Sproul does not disclose or suggest that a filter would be needed to address the potential coupling of RF power source 50 into the remote power source 32." Defendants' Opening, Ex. 11 ('276 Patent Glew Declaration) at ¶¶ 130–131. On its face, this statement appears to describe that Sproul does not disclose a filter, rather than the relative locations of the pulsed DC power supply and the RF power supply. Because Plaintiff's IPR statements "are amenable to multiple reasonable interpretations, they cannot be deemed clear and unmistakable." *3M Innovative Props.*, 725 F.3d at 1326.

Finally, with respect to the power supply manuals, the Court concludes that Plaintiff did not make a disclaimer. Again, the focus of Plaintiff's expert opinions appears to be directed towards a lack of a NBRF. Defendants' Opening, Ex. 11 ('276 Patent Glew Declaration) at ¶ 165 ("The references also do not show the use of a claimed filter. . . For example, Ex. 1025 mentions 'an ac blocking filter,' but does not indicate that the filter is a narrow band rejection filter."). Therefore, Plaintiff's IPR statements do not appear to be a "a clear and unmistakable disclaimer" of the relative locations of the pulsed DC power supply and the RF power supply.

Therefore, for the reasons described above, the Court concludes that Defendants' evidence does not meet the "exacting" standard required for disclaimer and should be construed according to its plain-and-ordinary meaning.

IV. CONCLUSION

In conclusion, for the reasons described herein, the Court adopts the below constructions as its final constructions.

SIGNED this 31st day of May, 2023.

ALAN D ALBRIGHT
UNITED STATES DISTRICT JUDGE

Term	Plaintiff's Proposed Construction	Defendant's Proposed Construction	Court's Preliminary Construction
<p>“coupled to the substrate” / “coupled to ... the substrate”</p> <p>U.S. Patent No. 7,381,657, Claims 1 and 6</p>	<p>Plain-and-ordinary meaning</p>	<p>“coupled to the substrate, such that the pulsed DC power source and the RF bias power are coupled to different components (target and substrate respectively)”</p>	<p>Plain-and-ordinary meaning (no disclaimer during IPR)</p>
<p>“providing...to the substrate”</p> <p>U.S. Patent No. 7,544,276, Claims 1 and 2</p>	<p>Plain-and-ordinary meaning</p>	<p>“providing ... to the substrate, such that the pulsed DC power source and the RF bias power are coupled to different components (target and substrate respectively)”</p>	<p>Plain-and-ordinary meaning (no disclaimer during IPR)</p>