

server . . . for reauthorization.” *Id.* at 2:57-59. Consequently, users could no longer access purchased media when “content providers discontinue[d] servers or even [went] out of business some years after DRM encrypted content was sold to consumers[.]” *Id.* at 2:59-62. In such cases, traditional DRM systems yielded a counterintuitive outcome: “hardware failure or property theft . . . could lead to a paying customer losing the right to recover purchased products.” *Id.* at 2:63-67. The ’555 patent allegedly solved this problem by providing “unlimited interoperability of digital media between unlimited machines with management of end-user access to the digital media.” *Id.* at 3:11-13. Figure 6 illustrates the invention’s general steps:

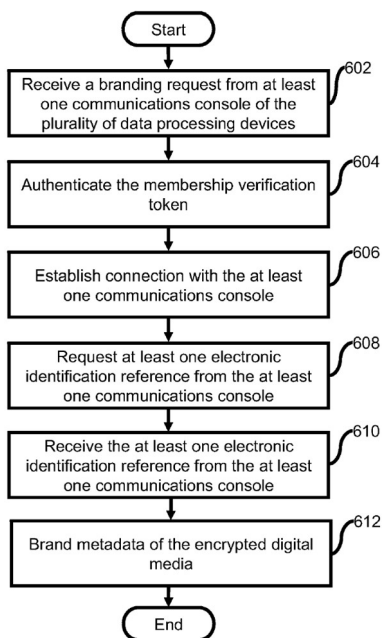

Id. at Fig. 6. Grecia claims this invention represents an advancement over the prior art in that it “employs electronic IC, as part of a web service membership, to manage access rights across a plurality of devices” rather than restrict digital media interoperability to a limited number of machines. *Id.* at 1:23-26.

The Complaint accuses Facebook’s Messenger app and Facebook Pay (collectively, the “Accused Product”) as the instrumentality infringing the ’555 patent. ECF No. 10 at 1.

Specifically, Grecia alleges that the Accused Product meets each limitation in claim 16 of the '555 patent by "associating a QR code with the user's account" and monitoring "access to the Facebook Pay account holder's digital money." *Id.* at 6. Facebook petitions the Court to dismiss that Complaint under Rule 12(b)(6) for failure to state a plausible infringement claim or under collateral estoppel because the '555 patent issues in this case are allegedly identical to those litigated in other proceedings. ECF No. 8 at 10.

II. LEGAL STANDARD

A. Rule 12(b)(6): Failure to State a Claim

A party may move to dismiss a claim if the complaint has "fail[ed] to state a claim upon which relief can be granted." FED. R. CIV. P. 12(b)(6). When considering a Rule 12(b)(6) motion, a court must assume that all well-pled facts are true and view them in the light most favorable to the non-moving party. *Bowlby v. City of Aberdeen*, 681 F.3d 215, 218 (5th Cir. 2012). However, courts "are not bound to accept as true a legal conclusion couched as a factual allegation." *Ashcroft v. Iqbal*, 556 U.S. 662, 678 (2009). To survive a Rule 12(b)(6) motion to dismiss, "a complaint must contain sufficient factual matter, accepted as true, to 'state a claim to relief that is plausible on its face.'" *Id.* (quoting *Bell Atl. Corp. v. Twombly*, 550 U.S. 544, 570 (2007)). "A claim has facial plausibility when the pleaded factual content allows the court to draw the reasonable inference that the defendant is liable for the misconduct alleged." *Id.* at 663. A complaint is insufficient if it offers only "labels and conclusions" or "a formulaic recitation of the elements of a cause of action." *Id.*

A literal infringement claim "require[s] a showing that each and every limitation set forth in a claim appears in the accused product." *Iron Oak Techs., LLC v. Acer Am. Corp.*, No. 6:17-CV-00143-RP-JCM, 2017 WL 9477677, at *3 (W.D. Tex. Nov. 28, 2017) (internal quotation

marks omitted). “[W]hen deciding a motion to dismiss, a court may ‘consider documents attached to or incorporated into the complaint and matters of which judicial notice may be taken.’” *Id.* at *2. “[A] plaintiff cannot assert a plausible claim for infringement under the *Iqbal/Twombly* standard by reciting the claim elements and merely concluding that the accused product has those elements.” *Bot M8 LLC v. Sony Corp. of Am.*, 4 F.4th 1342, 1353 (Fed. Cir. 2021). “[A] patentee may subject its claims to early dismissal by pleading facts that are inconsistent with the requirements of its claims.” *Id.* at 1346.

B. Collateral Estoppel

“Collateral estoppel protects a party from having to litigate issues that have been fully and fairly tried in a previous action and adversely resolved against a party-opponent.” *Ohio Willow Wood Co. v. Alps South, LLC*, 735 F.3d 1333, 1342 (Fed. Cir. 2013). “The issue of whether to apply collateral estoppel is a question of law.” *Bradberry v. Jefferson Cty., Tex.*, 732 F.3d 540, 549 (5th Cir. 2013). Thus, the issue of whether to apply collateral estoppel may be properly addressed in a motion to dismiss. *See, e.g., NetSoc, LLC v. Oath Inc.*, No. 18-CV-12267 (RA), 2020 WL 419469, at *1 (S.D.N.Y. Jan. 24, 2020); *Arunachalam v. Exxon Mobil Corp.*, No. 6:19-CV-00171-ADA, 2019 WL 10303695, at *1 (W.D. Tex. June 26, 2019).

Regional circuit law governs the general procedural question of whether collateral estoppel (i.e., issue preclusion) applies, but Federal Circuit law governs questions involving substantive issues of patent law. *Soverain Software LLC v. Victoria’s Secret Direct Brand Mgmt., LLC*, 778 F.3d 1311, 1314 (Fed. Cir. 2015). The Fifth Circuit has held that collateral estoppel applies if: “(1) the identical issue was previously adjudicated; (2) the issue was actually litigated; and (3) the previous determination was necessary to the decision.”² *Bradberry*, 732 F.3d at 548. Determining

² The Fifth Circuit also recognizes a fourth element, namely, “whether there are any special circumstances that make it unfair to apply the doctrine” of collateral estoppel. *Bradberry*, 732 F.3d at 548. However, this element is only

an “identity of issues” test implicates substantive patent law, meaning Federal Circuit law controls. *Ohio Willow*, 735 F.3d at 1342; *Soverain*, 778 F.3d at 1314. Collateral estoppel applies where there is “identity of the *issues*” and does not require patent claims to be “identical.” *Ohio Willow*, 735 F.3d at 1342 (emphasis in original); *see also Soverain*, 778 F.3d at 1319 (“Complete identity of claims is not required to satisfy the identity-of-issues requirement for claim preclusion.”) “If the differences between the unadjudicated patent claims and adjudicated patent claims do not materially alter the question of invalidity, collateral estoppel applies.” *Ohio Willow*, 735 F.3d at 1342.

III. DISCUSSION

Facebook moves for dismissal of Grecia’s Complaint on two grounds. First, it asserts Grecia is collaterally estopped from asserting claim 16. Second, it asserts that Grecia’s infringement allegations are threadbare, inconsistent, and implausible. The Court considers these arguments below.

A. Grecia is not collaterally estopped from asserting claim 16

Facebook argues that collateral estoppel bars Grecia from alleging infringement of the ’555 Patent because claim 16 is substantively identical to claims previously invalidated under 35 U.S.C. § 101 and 35 U.S.C. § 112 ¶ 6 in other proceedings. Facebook acknowledges that the claims contain different language, strictly speaking, but believes that such differences are minor. Ultimately, Facebook contends that Grecia cannot allege infringement because claim 16 discloses substantially the same invention as the invalidated claims and is therefore invalid. This Court disagrees, however, and will **DENY** Facebook’s Motion on this ground.

considered in offensive use of collateral estoppel by the plaintiff. *Id.* at 548-549; *Kariuki v. Tarango*, 709 F.3d 495, 506 (5th Cir. 2013). The fourth element does not apply in this case since it involves defensive use of collateral estoppel by the defendant.

1. Neither the § 101 validity issue nor the § 112, ¶ 6 definiteness issue is substantively identical to those previously adjudicated

In a separate district court proceeding, Judge Sullivan invalidated claim 21 of a related patent, U.S. Patent No. 8,533,860 (“the ’860 patent”), as indefinite. ECF No. 10 at 9 (citing *Grecia v. Mastercard Int’l Inc.*, No. 1:15-cv-09059-JGK (S.D.N.Y. Sept. 8, 2018), ECF No. 89). Because claim 21 of the ’860 patent bears some similarity to claims 15–16 of the ’555 Patent, Facebook argues that Judge Sullivan’s holding that claim 21 was indefinite collaterally estops Grecia from asserting claims 15–16. ECF No. 8 at 8–10. More specifically, Facebook relies on similarities between the two patents’ disclosures and the alleged invalidity of independent claim 15 to conclude that dependent claim 16 is also invalid. *Id.* at 9. Although the two claims are not strictly identical, Facebook contends that collateral estoppel applies because claim 16 is substantively identical to invalidated claim 21 for purposes of § 112, such that any minor differences in the respective claim language do not “materially alter the question of invalidity.” *Id.*

Grecia concedes that collateral estoppel applies to a claim term that the federal courts finally adjudged indefinite under § 112. ECF No. 10 at 11. But that term is “customization module,” not “computer product,” and there is no “customization module” in claim 16. Again, Grecia argues—as it did concerning pleading sufficiency—that Facebook attempts to broaden an indefiniteness ruling of the “customization module” in claim 21 beyond its reasonable limit by claiming that it applies to the “computer product” in claim 16. *Id.* The Federal Circuit, however, expressly declined to discuss whether collateral estoppel extended to the “computer product” term. *Id.* (citing *Grecia v. Samsung Elec. Am. Inc.*, 780 Fed. Appx. 912, 916-17 (Fed. Cir. 2019)). In fact, Grecia claims that case law teaches against evaluating the merits of the district court’s “computer product” construction because the relevant construction “had to be the reason for the loss” for collateral estoppel to apply. ECF No. 10 at 12 (citing *TecSec, Inc. v. Int’l Business*

Machines Corp., 731 F.3d 1336 (Fed. Cir. 2013)). But in *Samsung*, the court’s construction of “customization module” led to the loss, not any construction of “computer program product.” ECF No. 10 at 12. Thus, Grecia asserts that extending collateral estoppel’s preclusive effect to “computer program product” by way of *Samsung* is not only misguided; it is expressly rejected by the Federal Circuit. *Id.*

Separate from indefiniteness, Facebook alleges that collateral estoppel bars Grecia from asserting claim 16 of the ’555 Patent because it is substantively identical to claim 1 of U.S. Pat. No. 8,887,308 (“the ’308 Patent”) in two ways, which the court in the Southern District of New York invalidated under § 101. ECF No. 8 at 12 (citing *Grecia v. Bank of New York Mellon Corp.*, 456 F. Supp. 3d 525 (S.D.N.Y. 2020)). First, the court in *Bank of New York* found that claim 1 of the ’308 patent failed the first *Alice* step for reciting the “abstract idea of storing information about permission and identity for processing access requests.” *Id.* at 13. The ’308 and ’555 patents share the same character as a whole—that is, the same specification, priority claim, and the same six steps in the relevant claims—such that they present identical § 101 issues. *Id.* at 14. Second, the *Bank of New York* court found that claim 1 of the ’308 Patent failed the second *Alice* step because “writing down information about permission and identity” did not disclose a patent-eligible inventive concept. *Id.* Facebook contends that the term “branding” in the ’555 Patent is legally indistinguishable (*i.e.*, writing information about permission and identity) and therefore subject to the same ineligibility determination. *Id.* at 14. In Facebook’s view, claim 15 of the ’555 Patent adds nothing inventive to the subject matter in claim 1 of the ’308 patent and is therefore substantively identical for purposes of *Alice*. *Id.* at 15.

Grecia rebuts by offering three reasons that claim 16 of the ’555 Patent is unique and materially different than claim 1 of the ’308 Patent. ECF No. 10 at 16. First, claim 16 of the ’555

Patent is narrower in that it additionally requires “the method facilitating interoperability between a plurality of data processing services.” ECF No. 10 at 16 (citing ’555 Patent at 16:50-51). Second, 35 U.S.C. § 282 accords a presumption of validity to each patent claim. Facebook fails to produce the requisite clear and convincing evidence to overcome that presumption, especially in light of the examiner’s amendments tailoring the claims to the solution of granting interoperable access. ECF No. 10 at 14–15. Third, the doctrine of claim differentiation supports a finding that claim 16, as a dependent claim, is unique in that it creates a presumption that the limitation is not included in the independent claim. *Id.* The presence of a dependent claim that adds a particular limitation gives rise to a presumption that the limitation in question is not present in the independent claim. *Id.* Not only does this emphasize the individuality of claim 16, but it also teaches against Facebook’s attempt to equate the ’555 patent and the ’308 patent by lumping their claims together wholesale. *Id.* at 15.

This Court agrees with Grecia that neither the § 112 ¶ 6 nor § 101 issue is substantively identical to those previously litigated in other proceedings.

As for § 112 ¶ 6 definiteness, Grecia makes a compelling observation that the court’s ruling in *Mastercard* applies to “customization module”—a term conspicuously absent from claim 16—rather than “computer product.” To the extent Facebook suggests that these terms are interchangeable and therefore subject to the *Mastercard* holding, it petitions this Court to conduct a premature validity determination. This Court will not evaluate the merits of validity arguments on claim 16 before claim construction because, as previously noted, it is generally unwise to do so. *See Bancorp Servs., L.L.C. v. Sun Life Assur. Co. of Canada (U.S.)*, 687 F.3d 1266, 1273–74 (Fed. Cir. 2012) (“[I]t will ordinarily be desirable—and often necessary—to resolve claim

construction disputes prior to a § 101 analysis, for the determination of patent eligibility requires a full understanding of the basic character of the claimed subject matter.”).

This Court is equally unconvinced concerning § 101 eligibility. Grecia identifies an additional limitation in claim 16—“the method facilitating interoperability between a plurality of data processing services”—that creates a plausible distinction between *Bank of New York* and the case at hand. On its face, the plain language between the two claims is objectively different. Even if these differences do not prove the validity of claim 16 of the ’555 Patent, they may be significant enough to raise substantially different validity issues. Still, this Court cannot make a bona fide eligibility determination until it develops a “full understanding” of the claimed subject matter. Developing the requisite proficiency is a far-fetched (if not unattainable) goal when a court has not construed the patent’s claims or opened discovery, as is the case here. *See id.* (“Therefore, because claim construction can affect—and perhaps, in most cases, will affect—a court’s § 101 eligibility analysis, the Court believes that it is generally wiser—and more efficient—to wait to determine a patent’s § 101 eligibility until after issuing its claim construction order.” (emphasis in original)). The plain meaning presumption, validity presumption under § 282, and doctrine of claim differentiation may not be determinative in isolation, but they collectively signal to this Court that it must scrutinize claim 16 of the ’555 Patent holistically before broaching the subject of invalidity.

By alleging detailed validity arguments at this stage, Facebook seeks to prevail—as it did above—on a ground not yet ripe for dispute. To rule in Facebook’s favor at this stage of litigation, this Court would have to (1) presume that the ’555 Patent is invalid under § 101 based on *Mastercard* and *Bank of New York*, (2) presume that differences between the claim 16 of the ’555 patent and claim 21 of the ’860 patent do not “materially alter the question of validity” before

claim construction, and (3) apply collateral estoppel to invalidate the '555 patent under § 101. In effect, Facebook petitions this Court to indulge a series of “unsound presumptions” concerning the validity of the '555 patent. Just as this Court rejected those presumptions in the past, so will it reject them today. *See SmileDirectClub, LLC v. CandidCare Co.*, No. 6:20-CV-01115-ADA, 2021 WL 3598287, at *3 (W.D. Tex. July 1, 2021). Despite language similarities between claim 16 of the '555 patent and the claims in *Mastercard* and *Bank of New York*, this Court cannot appreciate the full context of these patents at this stage of litigation. Accordingly, this Court refuses to accept that claim 16 is estopped from assertion on either ground grounds until claim construction occurs.

2. Both the § 101 validity and the § 112, ¶ 6 definiteness issues were “actually litigated.”

Under Fifth Circuit precedent, an issue is “actually litigated” for collateral estoppel purposes when “the issue is raised, contested by the parties, submitted for determination by the court, and determined.” *In re Keaty*, 397 F.3d 264, 273 (5th Cir. 2005) (quotation omitted).

In *Mastercard*, Judge Sullivan issued a ruling after Grecia argued its definiteness position in multiple claim construction briefs and at the claim construction hearing. Grecia appealed the decision to the Federal Circuit, which affirmed Sullivan’s holding. Additionally, in *Bank of New York*, Judge Caproni found claim 1 of the '308 Patent invalid under § 101 after considering Grecia’s arguments. Grecia subsequently filed two additional memoranda, which the court considered and denied. Grecia then appealed the decision to the Federal Circuit, which affirmed Caproni’s holding. Therefore, this element is satisfied for both issues.

3. Both the § 101 validity and the § 112, ¶ 6 definiteness determinations were necessary to the courts’ decisions.

The parties do not dispute that Judge Sullivan’s indefiniteness finding under § 112 ¶ 6 in *Mastercard* was necessary to support the invalidity judgment. They also do not dispute that Judge

Caproni's patent ineligibility finding under § 101 in *Bank of New York* was necessary to support the invalidity judgment. Therefore, this element is satisfied for both issues.

Invalidity under § 101 represents a particularly complicated and volatile area of patent law. *See Sound View Innovations, LLC v. Walmart Inc.*, No. CV 19-660-CFC-CJB, 2019 WL 7067056, at *4. Based on apparent similarities between the disclosures of the '555 Patent and various related patents, however, Facebook requests that this Court extend other courts' invalidity findings to the '555 Patent. But Facebook overlooks those as *different* proceedings in *different* courts regarding *different* patents. As a result, this Court finds that collateral estoppel does not bar Grecia's infringement claim. *See id.* (finding that a previous decision by a different court finding a patent invalid under § 101 is not “sufficiently firm” such that it should be accorded preclusive effect” under the doctrine of collateral estoppel).

B. Grecia fails to plead infringement of the '555 patent in sufficient detail.

Facebook argues that the Grecia failed to adequately plead infringement for two reasons. First, the Complaint lacks an adequate factual basis to reasonably infer that a Facebook Pay user's payment information “corresponds” to any “encrypted digital media.” Second, Facebook argues that the Complaint neglects to advance allegations for all claim limitations, including the “encrypted digital media” and “metadata of the encrypted digital media” limitations. This Court agrees.

1. Grecia's “Membership Verification Token” allegations contradict its statements to the Patent Office.

Facebook contends that a plain interpretation of claim 16's “correspond” term requires a relationship or correspondence between the “membership verification token” and the “encrypted digital media.” ECF No. 8 at 17. Grecia proposes that a Facebook Pay user's “PayPal account or Debit and Credit Card number” is the claimed “membership verification token.” ECF No. 1 ¶ 15,

20; *see also* ECF No. 1-3 at 2. As Facebook points out, however, Grecia cannot plausibly allege that a “PayPal account or Debit and Credit Card number” corresponds to any “encrypted digital media” because it argued in an *inter partes review* (“IPR”) before the Patent Trial and Appeal Board (“PTAB”) that payment account numbers do not correspond to any particular digital media—they only correspond to a payment account. ECF No. 8-10 (Preliminary Response, *Unified Patents Inc. v. Grecia*, IPR2016-00789, Paper No. 5 (P.T.A.B. June 22, 2016)) at 21-22 (“credit card information ... cannot be the ‘membership verification token’”). To survive the IPR, Grecia expressly disavowed any position that payment account information could constitute a “membership verification token . . . corresponding to the encrypted digital media.” *Id.*

In Grecia’s view, Facebook unduly broadens the PTAB decision’s scope to hold that credit card accounts are never membership verification tokens. ECF No. 10 at 10. Instead, Grecia claims that the holding applies only to eBooks, the digital media in the disputed prior art reference, DeMello (U.S. Patent No. 6,891,953). *Id.* DeMello failed to teach or suggest that the user’s credit card information corresponds to the eBook, but extending this holding to the Accused Product, Grecia warns, is a bridge too far at the pleading stage. *Id.* Still, Grecia maintains that Facebook misses the point: the determinative question for this motion is whether Grecia sufficiently pleaded its infringement theory, not whether Grecia can prove it. Here, Grecia allegedly met its burden by supplying claim charts that demonstrate how the Accused Product practices each limitation of claim 16. ECF No. 10 at 9. By petitioning for dismissal with a set of evidentiary critiques, according to Grecia, Facebook attempts to impose an artificially heightened pleading standard for a motion to dismiss. *Id.* at 11.

This Court agrees that Grecia’s Complaint has not sufficiently pleaded infringement of claim 16 of the ’555 Patent given its communications with the PTAB. Such communications, as

matters of public record, are subject to judicial notice and appropriate for this Court to consider at the pleading stage. *Data Engine Techs. LLC v. Google LLC*, 906 F.3d 999, 1008 n.2 (Fed. Cir. 2018) (“On a motion for judgment on the pleadings, however, the court may consider ‘matters of public record,’” such as “[p]rosecution histories”); *Uniloc USA, Inc. v. ADP, LLC*, 772 F. App’x 890, 898 n.3 (Fed. Cir. 2019) (“The prosecution history is part of the intrinsic record of the patent” and “thus subject to judicial notice and may be considered in our de novo review of the district court[’s]” ruling on a motion to dismiss); *Trustees of Columbia Univ. in City of N.Y. v. NortonLifeLock, Inc.*, No. 3:13CV808, 2019 WL 7040931, at *2 (E.D. Va. Dec. 20, 2019) (citing *Aylus Networks, Inc. v. Apple, Inc.*, 856 F.3d 1353, 1362 n.3 (Fed. Cir. 2017)) (“The prosecution history also includes proceedings before the Patent Trial and Appeal Board (the ‘PTAB’), such as *inter partes review*.”). Thus, this Court can—and does—take judicial notice of Grecia’s PTAB communications during IPR to evaluate whether Grecia adequately pleaded infringement.

To survive IPR, Grecia disclaimed any correspondence between credit card information and the “encrypted digital media” of the ’555 Patent. Claims 15-16 of the ’555 Patent require, in part, that the computer program product receive and authenticate a “membership verification token provided by a first user, corresponding to the encrypted digital media.” ’555 Patent at 16:54–59. In other words, there must be some relationship between the “membership verification token” and the “encrypted digital media.” Grecia’s Complaint alleges that a Facebook Pay user’s “PayPal account or Debit and Credit Card number” is the claimed “membership verification token.” ECF No. 1 at 6–7. Yet, in IPR, Grecia asserted that credit card information could not be the “membership verification token” because a credit card number corresponds to the credit card account and not digital media. Preliminary Response, *Unified Patent Inc. v. Grecia*, IPR2016-00789, Paper No. 5 (P.T.A.B. June 22, 2016) at 21–22. Ultimately, Grecia seeks to benefit from claiming a distinction between the ’555 Patent and the DeMello reference during IPR yet refuses

to confront the drawback of claiming the same distinction in litigation. Grecia's allegations contradict prior sworn statements concerning the invention's scope during IPR and, therefore, fail to "articulate why it is plausible that the accused product infringes the patent claim." *Bot M8*, 4 F.4th at 1355. Grecia cannot plausibly allege infringement on this ground.

2. Grecia's allegations identify No "Encrypted Digital Media" or "Metadata of the Encrypted Digital Media" required in claim 16.

Contrary to Facebook's characterization, Grecia asserts that its pleading exceeded the obligation to allege with particularity how Facebook receives a request to brand the "encrypted digital media" and subsequently brands "the metadata of the encrypted digital media." ECF No. 10 at 9-10. Yet Facebook responds that the allegation most closely related to any "encrypted digital media" in the Complaint contains, at best, vague allusions to "digital money." ECF No. 8 at 18 (citing ECF No. 1 at 6 (stating that accused products include "code that facilitates monitoring access to the Facebook Pay account holder's digital money")). Because digital "media" and digital "money" are different, Facebook argues that Grecia cannot plausibly allege that "digital money" meets the "encrypted digital media" limitation. *Id.* Moreover, Facebook notes that Grecia disavowed this broader interpretation to the PTAB by specifically distinguishing a user's "credit card account" (i.e., "digital money") from "digital media." *Id.*

This distinction is critical, according to Facebook, because Grecia cannot point to branded "metadata *of the* encrypted digital media" without identifying any specific "encrypted digital media." ECF No. 8 at 20. Grecia sidesteps this problem by alleging that Facebook Pay stores an "association" between the membership verification token and the electronic identification reference, not that it brands metadata "by writing the membership verification token and the electronic identification reference *into the metadata*," as required by claim 15. *Id.* Thus, Facebook argues that Grecia's allegations fail as a matter of law because they cannot plausibly state a claim

of infringement against the Accused Product. *Id.* Again, Grecia stresses that it is not required to prove its case in the Complaint. ECF No. 10 at 8. As Grecia would have this Court believe, there is no obligation requiring Grecia to prove that an account holder's payment information is branded and associated with the QR code at this stage—Grecia alleged it, and that's enough. *Id.*

This Court agrees that Grecia's Complaint has not sufficiently pleaded infringement of this limitation in claim 16 of the '555 patent. Grecia points to paragraph 21 of the Complaint to prove that it has alleged with particularity how Facebook brands "the metadata of the encrypted digital media," but the Complaint contains no such allegation in either of the two paragraphs labeled "21."

As for the first paragraph labeled "21," Grecia states that Facebook infringes with its "internal testing, quality assurance, research and development, and troubleshooting." That level of detail, however, falls short of the relevant pleading standard given the complexity of the disputed technology. The detail required to plead direct infringement adequately depends on "the complexity of the technology, the materiality of any given element to practicing the asserted claim(s), and the nature of the allegedly infringing device." *Bot M8*, 4 F.4th at 1353. Here, the membership verification tokens and branded encrypted metadata of digital rights management schemes are no less complicated than the video-game algorithms in *Bot M8*. Because Grecia alleges infringing processes general enough to apply a broad range of technologies, their allegations amount to blanket assertions of infringement insufficient to put Facebook on notice of Grecia's general infringement theory, much less a particular one. This is true even if we "accept all factual allegations in the complaint as true and construe the pleadings in the light most favorable to" Grecia. *See id.* A plaintiff cannot establish "why it is plausible that the accused product infringes the patent claim" simply by articulating why the accused product may practice the prior art as Grecia does. *See id.*

As for the second paragraph labeled “21,” Grecia relies on an asserted association between the “membership verification token . . . and the Facebook Pay QR identifier to the Facebook Pay Computer Product metadata.” ECF No. 1 at 4. Yet, this statement cannot plausibly allege infringement of the “metadata of the encrypted digital media” because it accuses Facebook Pay as a “computer product” rather than any encrypted digital media. Furthermore, Grecia resorted to parroting claim language when pressed at a hearing before this Court to identify an accused instrumentality of the encrypted digital media, insisting only that Facebook Pay’s encrypted digital media is the encrypted digital media. The mere recitation of claim language, however, is insufficient to assert a claim, even on a motion to dismiss. Thus, Grecia’s contentions cannot lead to a reasonable inference that Facebook Pay *brands* the metadata of the encrypted digital media. To rebut, Grecia makes an unavailing appeal to “digital money” *without explaining how* this shows that the alleged “membership verification token” corresponds to any encrypted digital media. But “it is the *quality* of the allegations, not the quantity, that matters.” *Bot M8*, 4 F.4th at 1353. In this Court’s judgment, Grecia’s allegation without explanation is threadbare at best.

Grecia correctly notes that it is not obligated to prove its case at this stage of litigation. However, the paragraphs Grecia points to in its Complaint fail to plausibly articulate how Facebook infringed on claim 16 of the ’555 Patent. Given the complexity of the disputed technology, Grecia falls short of providing sufficient evidence to show that infringement is a reasonable inference to draw.

IV. CONCLUSION

For the foregoing reasons, the Court **GRANTS** Defendant’s Rule 12(b)(6) Motion to Dismiss Grecia’s infringement claims. It is therefore **ORDERED** that all Grecia’s claims against Defendant in this case are **DISMISSED** with prejudice.

SIGNED this 6th day of June, 2022.

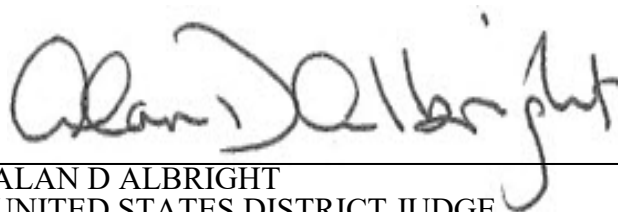
A handwritten signature in black ink that reads "Alan D Albright". The signature is written in a cursive style with a large, looped "A" and "D".

ALAN D ALBRIGHT
UNITED STATES DISTRICT JUDGE