

EXHIBIT B



US007725725B1

(12) **United States Patent**
Odom

(10) **Patent No.:** **US 7,725,725 B1**
(45) **Date of Patent:** ***May 25, 2010**

(54) **USER-SELECTABLE SIGNATURES**

(76) Inventor: **Gary Odom**, 123 NW. 12th Ave., #1545,
Portland, OR (US) 97209

(*) Notice: Subject to any disclaimer, the term of this
patent is extended or adjusted under 35
U.S.C. 154(b) by 733 days.

This patent is subject to a terminal dis-
claimer.

(21) Appl. No.: **11/615,966**

(22) Filed: **Dec. 23, 2006**

Related U.S. Application Data

(63) Continuation of application No. 10/090,520, filed on
Mar. 4, 2002, now Pat. No. 7,350,078.

(60) Provisional application No. 60/286,457, filed on Apr.
26, 2001.

(51) **Int. Cl.**
H04L 9/32 (2006.01)

(52) **U.S. Cl.** **713/176; 713/183**

(58) **Field of Classification Search** **713/176,**
713/183

See application file for complete search history.

(56) **References Cited**

U.S. PATENT DOCUMENTS

| | | |
|---------------|--------|------------------------------|
| 5,226,172 A | 7/1993 | Seymour et al. |
| 5,229,764 A | 7/1993 | Matchett |
| 5,442,342 A | 8/1995 | Kung |
| 5,491,752 A | 2/1996 | Kaufman et al. |
| 5,638,513 A * | 6/1997 | Ananda 726/5 |
| 5,664,099 A * | 9/1997 | Ozzie et al. 726/29 |
| 5,787,169 A * | 7/1998 | Eldridge et al. 713/165 |
| 5,896,497 A | 4/1999 | Halstead |
| 6,052,468 A | 4/2000 | Hillhouse |
| 6,193,153 B1 | 2/2001 | Lambert |
| 6,205,204 B1 | 3/2001 | Morganstein et al. |
| 6,209,104 B1 | 3/2001 | Jalili |
| 6,442,692 B1 | 8/2002 | Zilberman |

| | | | |
|-------------------|---------|------------------------|---------|
| 6,466,781 B1 * | 10/2002 | Bromba et al. | 455/411 |
| 6,480,825 B1 * | 11/2002 | Sharma et al. | 704/270 |
| 6,618,806 B1 * | 9/2003 | Brown et al. | 713/186 |
| 6,636,975 B1 * | 10/2003 | Khidekel et al. | 726/10 |
| 6,647,400 B1 * | 11/2003 | Moran | 707/205 |
| 6,647,498 B1 * | 11/2003 | Cho | 726/17 |
| 6,651,168 B1 * | 11/2003 | Kao et al. | 713/185 |
| 6,657,614 B1 * | 12/2003 | Ito et al. | 345/168 |
| 6,671,813 B2 * | 12/2003 | Ananda | 726/3 |
| 6,732,278 B2 * | 5/2004 | Baird et al. | 726/7 |
| 6,751,734 B1 * | 6/2004 | Uchida | 713/186 |
| 6,766,456 B1 * | 7/2004 | McKeeth | 726/2 |
| 6,895,514 B1 * | 5/2005 | Kermani | 726/19 |
| 6,948,154 B1 * | 9/2005 | Rothermel et al. | 717/128 |
| 6,957,337 B1 * | 10/2005 | Chainer et al. | 713/186 |
| 7,065,786 B2 * | 6/2006 | Taguchi | 726/18 |
| 7,136,490 B2 * | 11/2006 | Martinez et al. | 380/284 |
| 7,200,804 B1 * | 4/2007 | Khavari et al. | 715/230 |
| 7,386,731 B2 * | 6/2008 | Sanai et al. | 713/183 |
| 7,409,705 B2 * | 8/2008 | Ueda et al. | 726/5 |
| 7,444,517 B2 * | 10/2008 | Dayan et al. | 713/184 |
| 7,506,174 B2 * | 3/2009 | Davis et al. | 713/186 |
| 2001/0047488 A1 * | 11/2001 | Verplaetse et al. | 713/202 |

(Continued)

Primary Examiner—David García Cervetti

(57) **ABSTRACT**

Computer login may comprise any user-determined submission. A user may select among different devices for input, select the signal content, and as well select the types of signals used for a login signature. Account identification may be inferred by signature rather than explicitly stated. A plurality of discontinuous data blocks in a plurality of files may be employed for validation. The paths to data used in validation may be multifarious, regardless of the prospects for successful authorization.

20 Claims, 10 Drawing Sheets

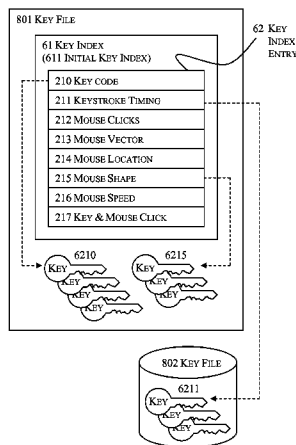

US 7,725,725 B1

Page 2

U.S. PATENT DOCUMENTS

| | | | | | | | | | |
|--------------|-----|--------|----------------------|---------|--------------|-----|---------|----------------------|---------|
| 2002/0002678 | A1* | 1/2002 | Chow et al. | 713/169 | 2002/0091937 | A1* | 7/2002 | Ortiz | 713/200 |
| 2002/0002685 | A1* | 1/2002 | Shim | 713/200 | 2002/0141586 | A1* | 10/2002 | Margalit et al. | 380/270 |
| 2002/0083339 | A1* | 6/2002 | Blumenau et al. | 713/201 | 2003/0056120 | A1* | 3/2003 | Liu et al. | 713/202 |
| 2002/0087894 | A1* | 7/2002 | Foley et al. | 713/202 | 2004/0128508 | A1* | 7/2004 | Wheeler et al. | 713/170 |
| | | | | | 2006/0036547 | A1* | 2/2006 | Yasuhara | 705/44 |

* cited by examiner

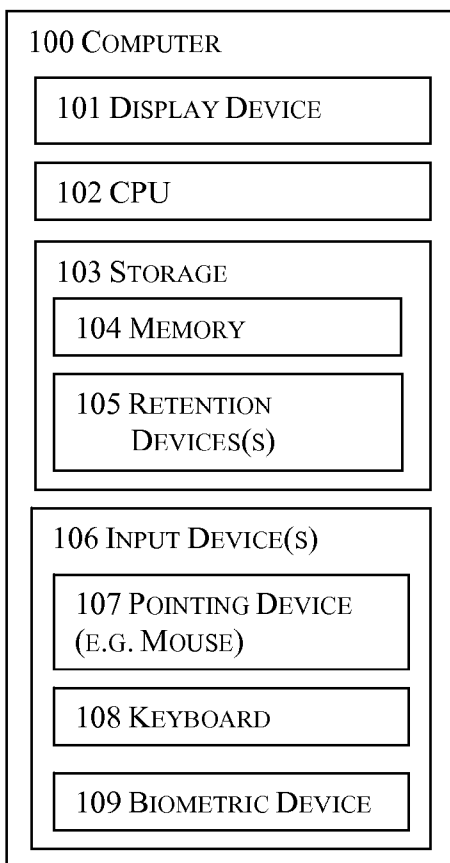

FIGURE 1

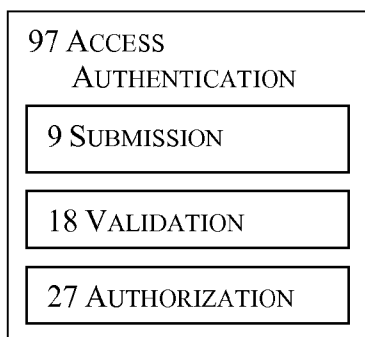

FIGURE 2

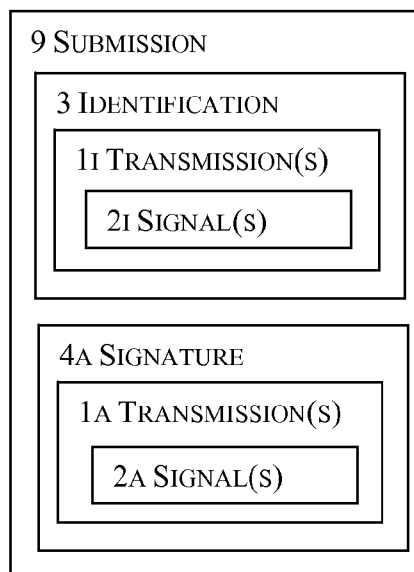

FIGURE 3

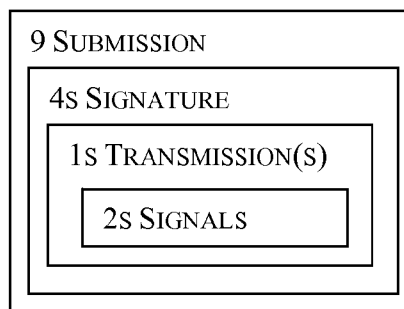

FIGURE 4

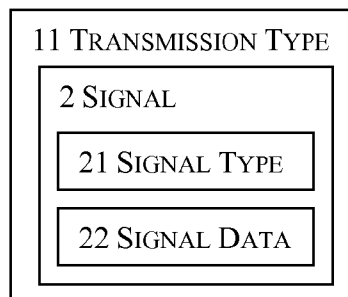

FIGURE 5

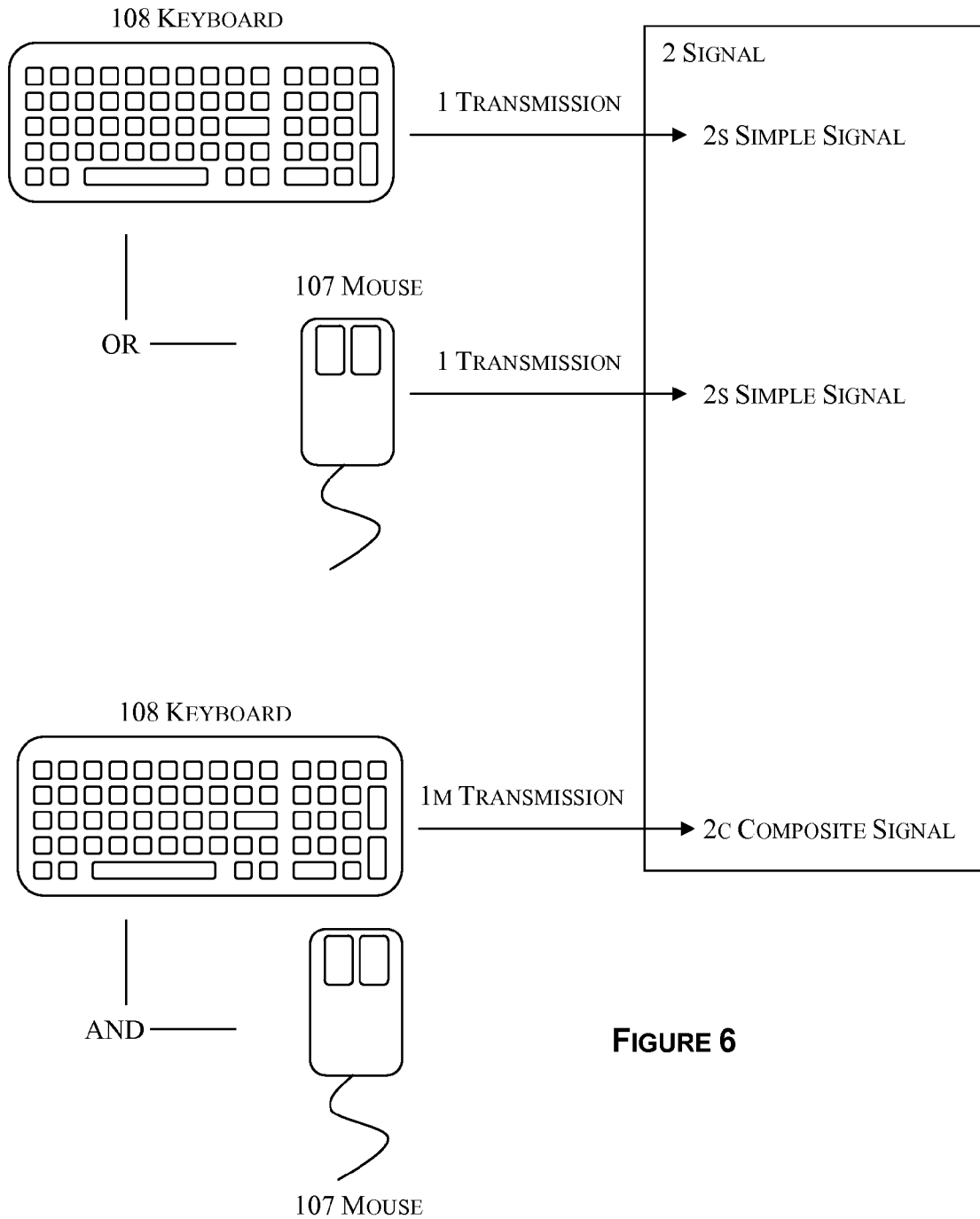

FIGURE 6

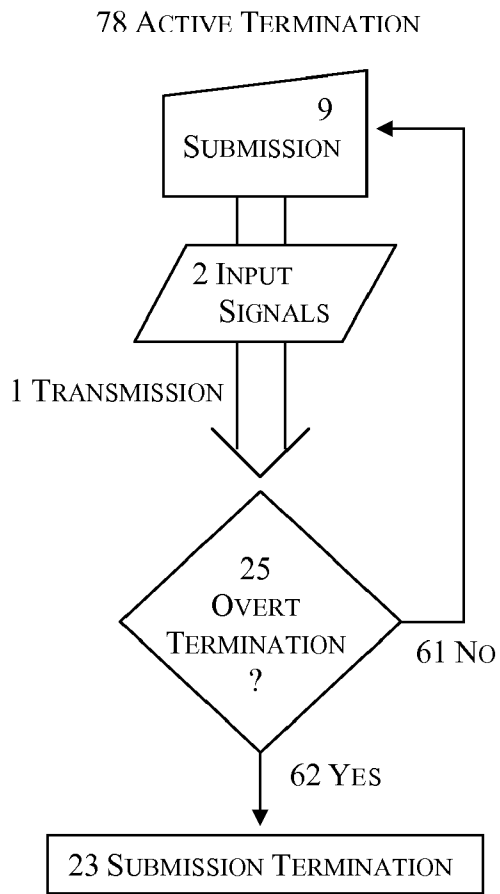

FIGURE 7

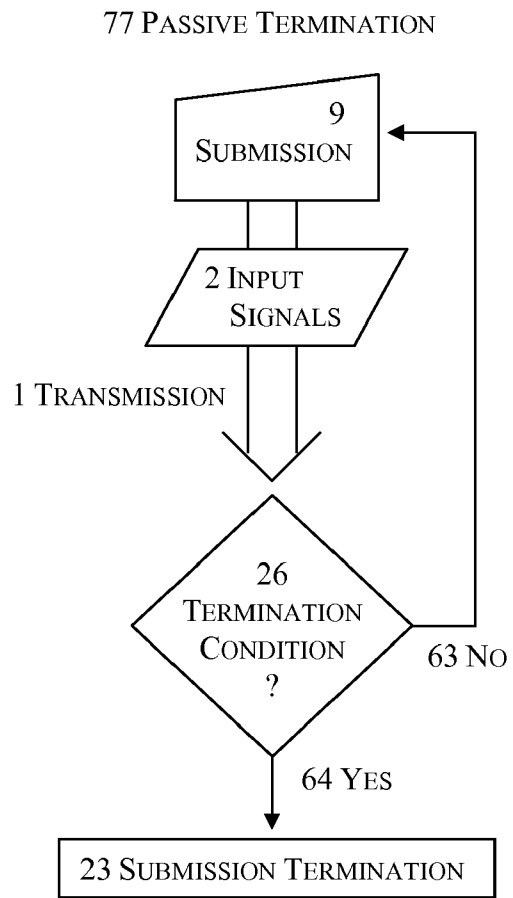

FIGURE 8

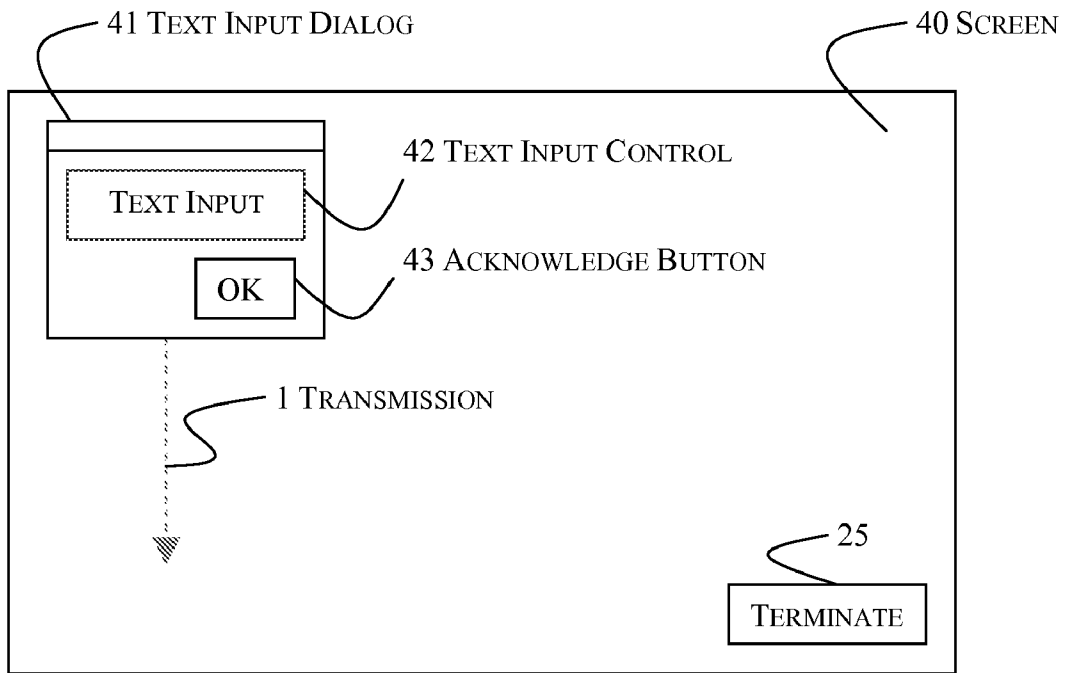

FIGURE 9

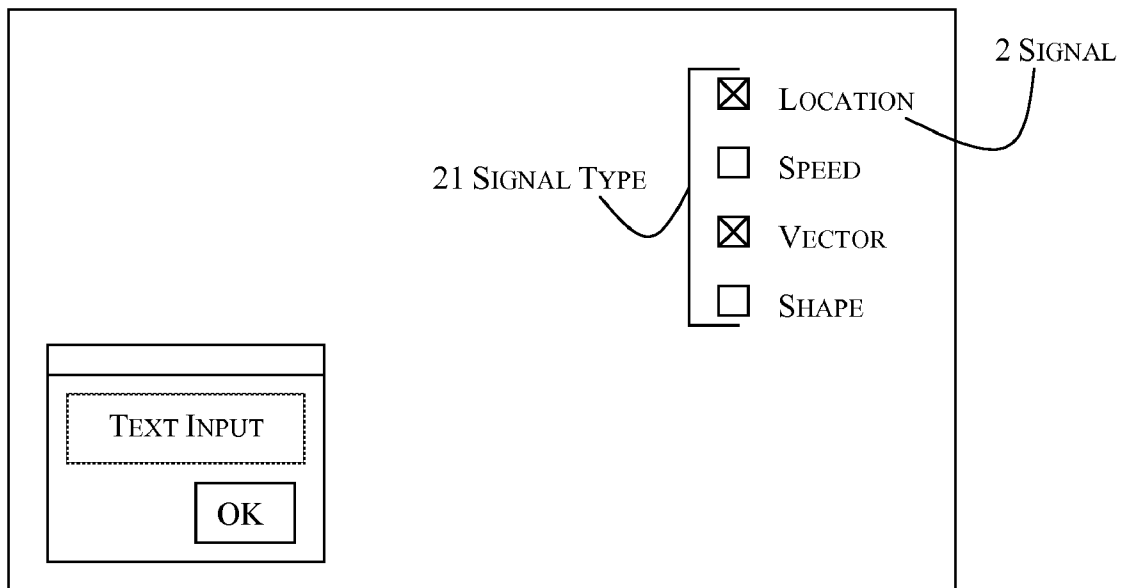

FIGURE 10

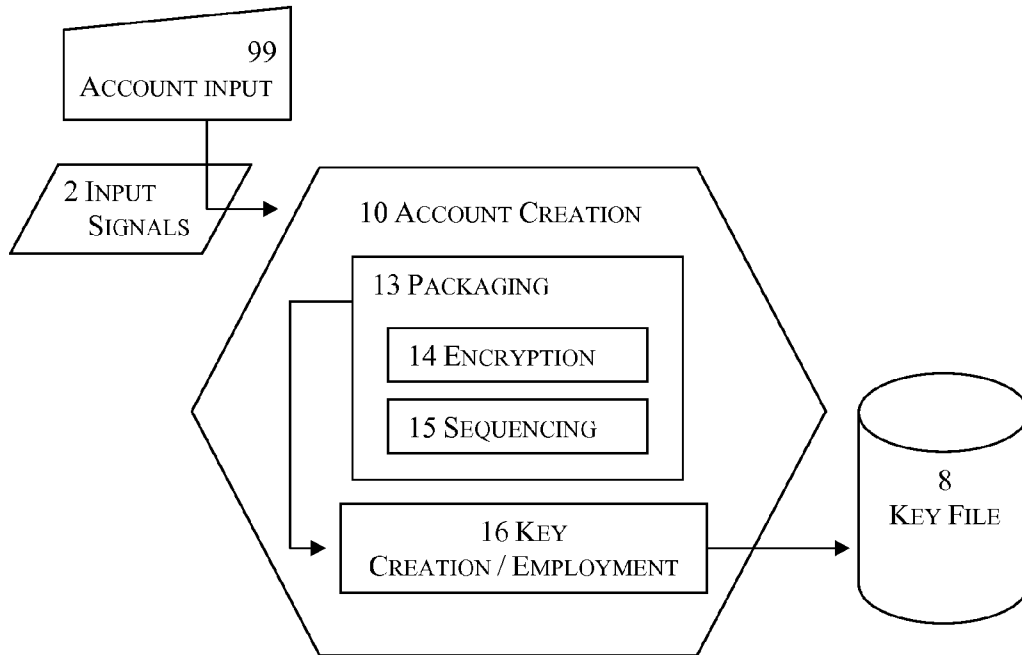

FIGURE 11

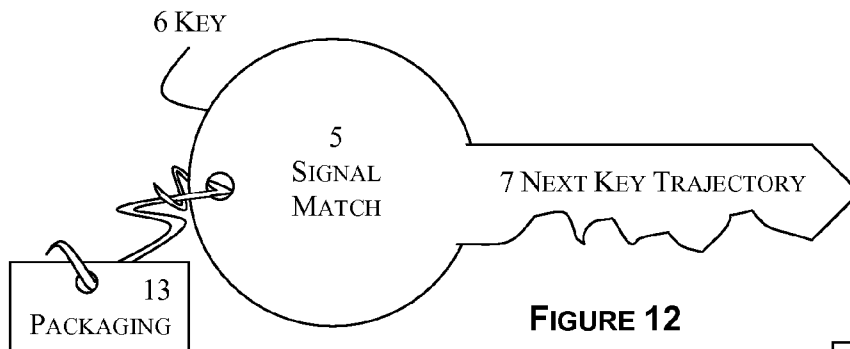

FIGURE 12

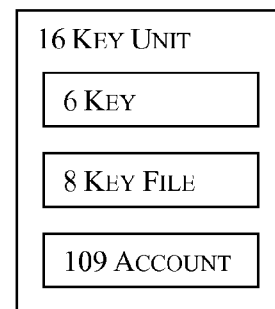

FIGURE 13

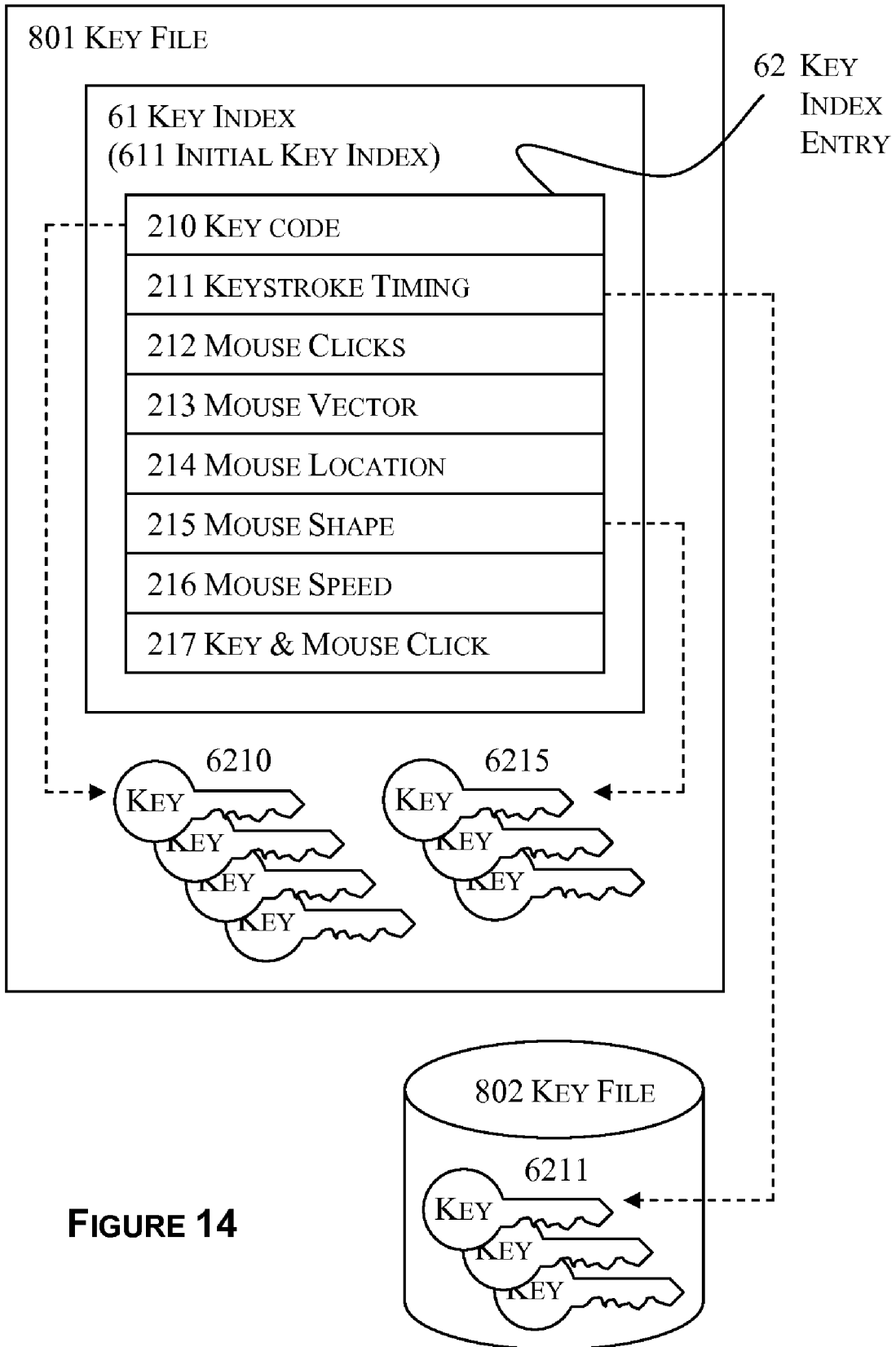

FIGURE 14

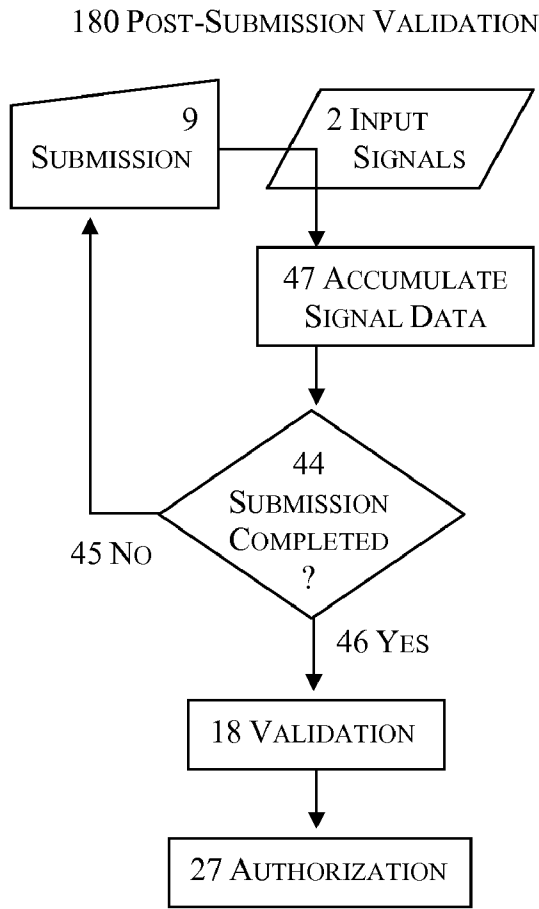

FIGURE 15

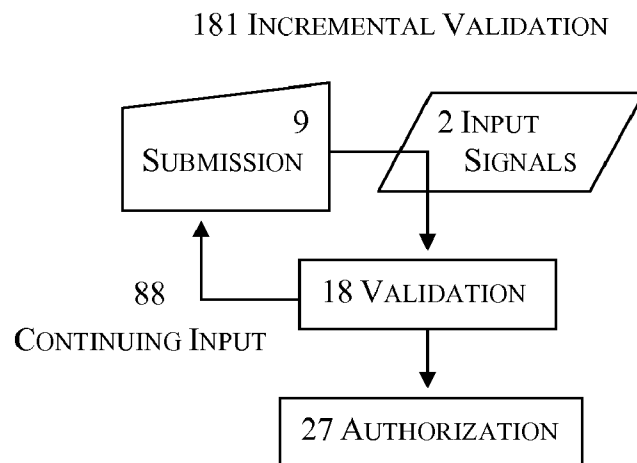

FIGURE 16

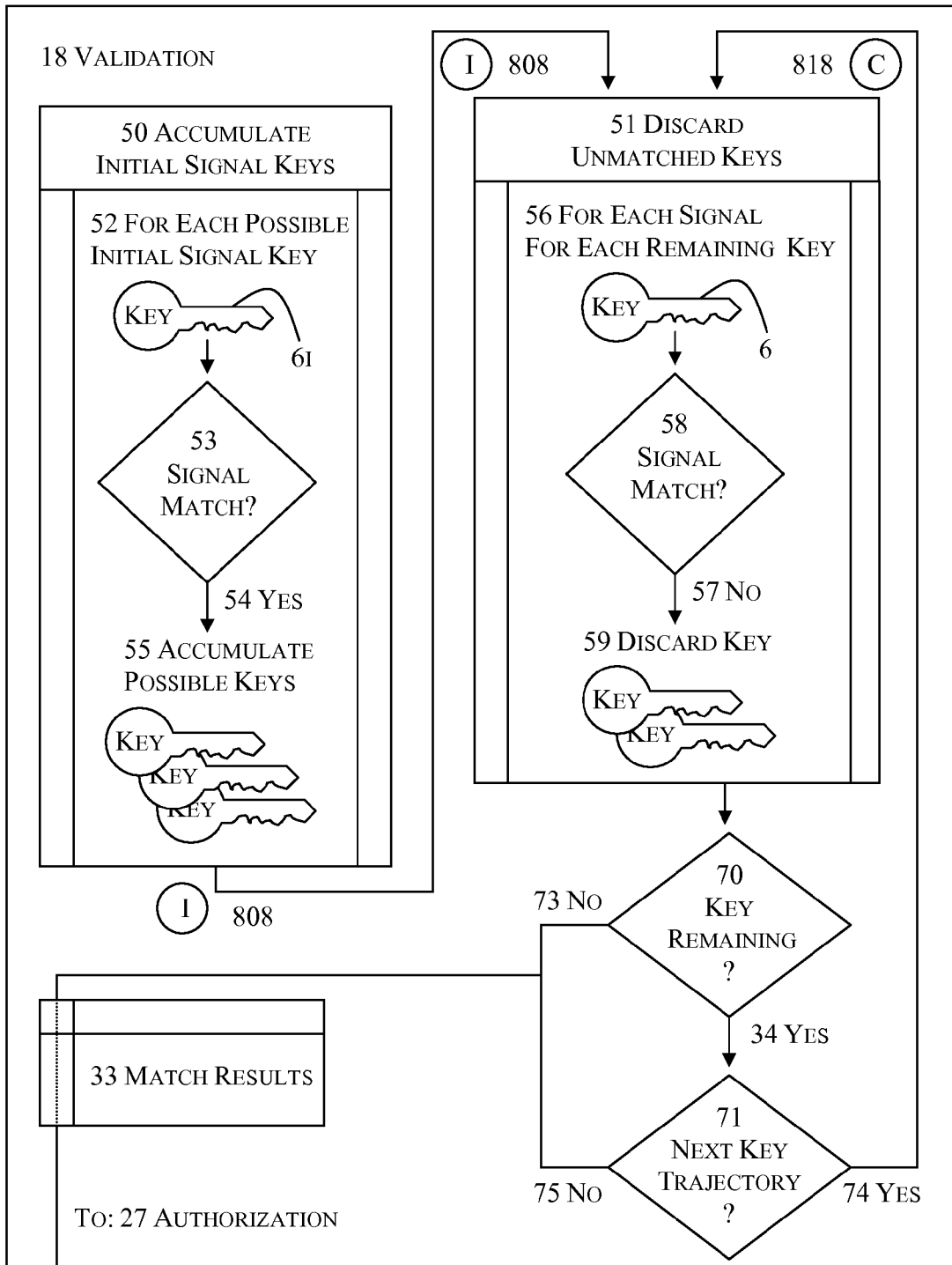

FIGURE 17

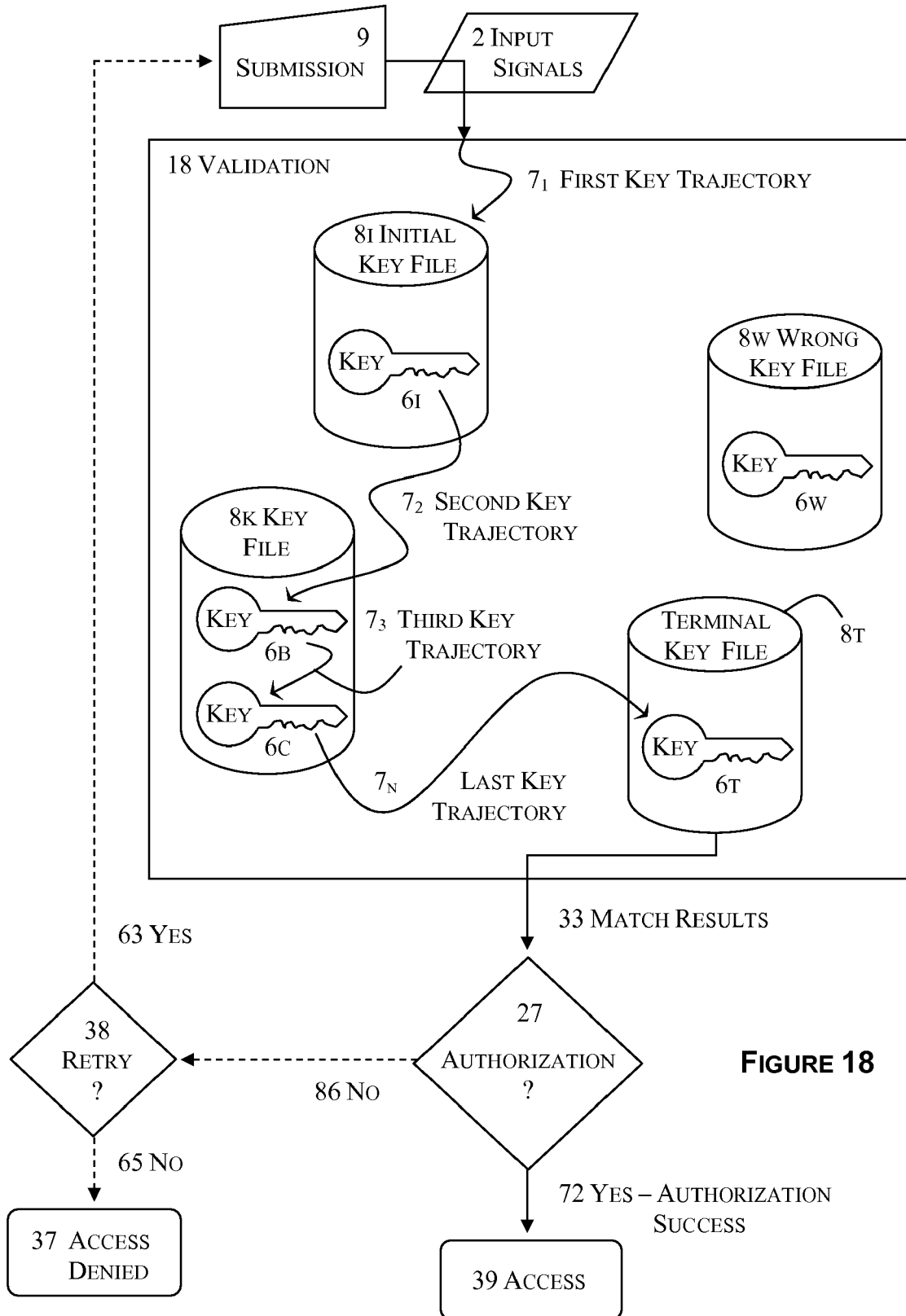

FIGURE 18

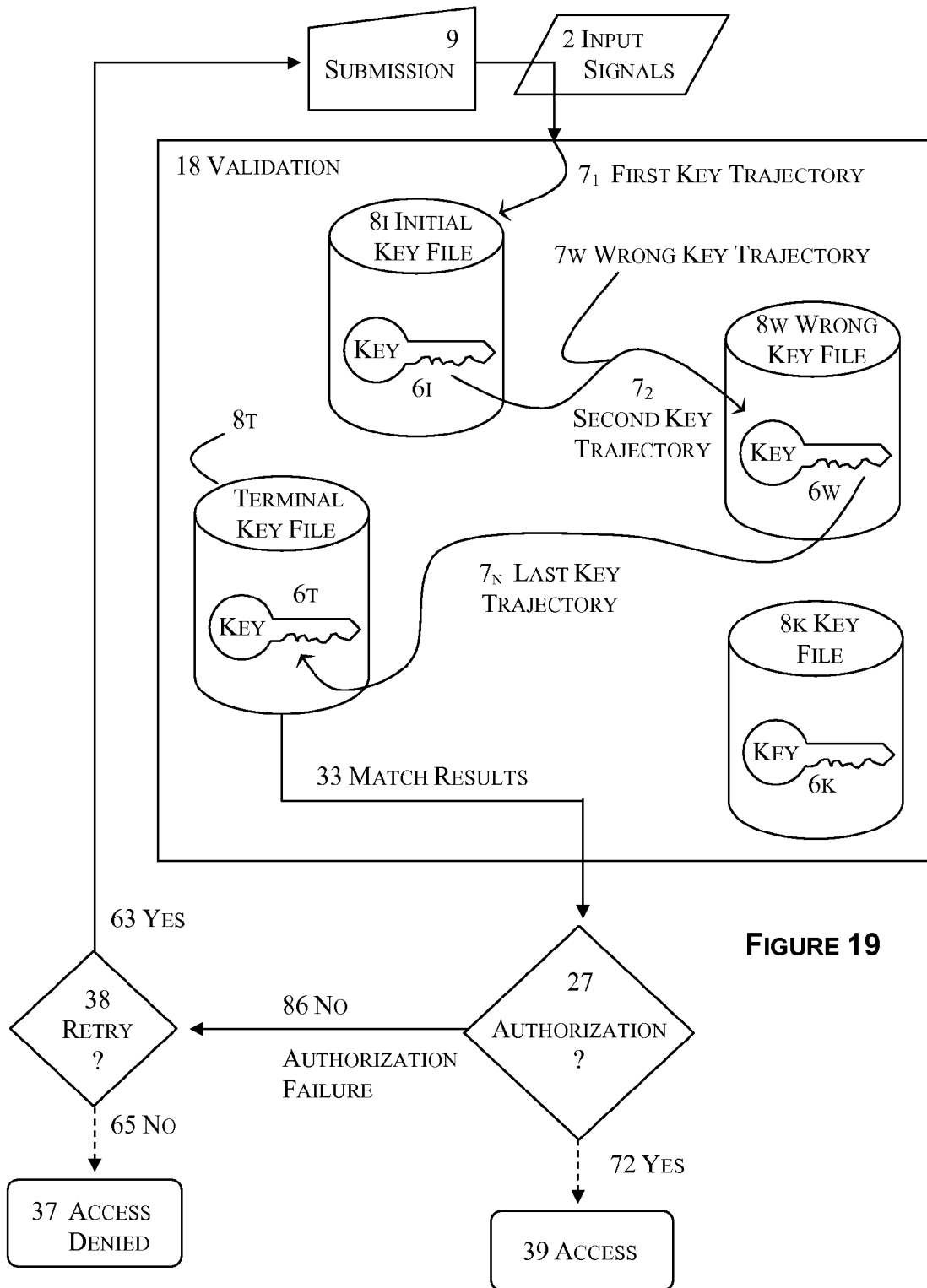

FIGURE 19

1

USER-SELECTABLE SIGNATURES**CROSS-REFERENCE TO RELATED APPLICATIONS**

This application is a continuation of U.S. patent application Ser. No. 10/090,520 filed Mar. 4, 2002 now U.S. Pat. No. 7,350,078, which is a non-provisional filing of provisional application 60/286,457, filed on Apr. 26, 2001. As such, this application claims priority to Apr. 26, 2001.

STATEMENT REGARDING FEDERALLY SPONSORED RESEARCH OR DEVELOPMENT

Not Applicable

THE NAMES OF THE PARTIES TO A JOINT RESEARCH AGREEMENT

Not Applicable

INCORPORATION-BY-REFERENCE OF MATERIAL SUBMITTED ON A COMPACT DISC

Not Applicable

BACKGROUND OF THE INVENTION

1. Field of the Invention

The relevant technical field is computer login security.

2. Description of the Related Art

Including Information Disclosed Under 37 CFR 1.97 and 1.98

Computer login traditionally consists of a user typing in an account name and a password. Historically, access validation (authenticating a password one an account name is known) has been through reading data from a single password file comprising account name and encrypted password. Once a single account and a typed password is known, system security can be compromised. Once encryption for a single password is broken, all other passwords are potentially comprised, as all passwords and account names are conveniently located in the single password file and use the same encryption.

BRIEF SUMMARY OF THE INVENTION

Computer login may comprise any user-determined submission, including a plurality of transmissions for which submission may be passively terminated. Preferably a user determines the input devices and signal types as well as the content of signals. This makes submission theft more difficult and less likely.

Account identification may be inferred by signature rather than explicitly stated. Overt account identification provides an entry point for hacking; with inferred account identification, this entry point is eliminated.

A plurality of discontinuous data blocks (keys) in a one or more files may be employed for validation. This ameliorates having a single authentication key that, once accessed, may be deciphered and security compromised.

Multiple trajectories to keys, hence multiple paths to authorization as well as ersatz trajectories and paths when submission will not garner authorized access, obfuscate validation protocol to spy software and devices.

2

These aspects are independent: one does not rely upon the other. Any one or all may be employed to enhance computer login security.

Access privileges for accounts are not germane. Determining or setting account access privileges are separate operations that occur after submission validation and authorization.

BRIEF DESCRIPTION OF THE SEVERAL VIEWS OF THE DRAWINGS

FIG. 1 is a block diagram of a computer suitable for practicing the invention.

FIG. 2 depicts the access authentication process.

FIG. 3 depicts an embodiment of identification and signature comprising submission.

FIG. 4 depicts an embodiment of signature solely comprising submission.

FIG. 5 depicts classifying signals by their transmission and signal types.

FIG. 6 depicts simple and composite signals.

FIG. 7 depicts active submission termination.

FIG. 8 depicts passive submission termination.

FIGS. 9 & 10 depict example submission screens.

FIG. 11 depicts account creation.

FIG. 12 depicts a key.

FIG. 13 depicts a key unit.

FIG. 14 depicts an example of key indexing.

FIG. 15 depicts validation after submission termination.

FIG. 16 depicts incremental validation.

FIG. 17 depicts the validation process.

FIG. 18 depicts an example of validation key trajectory resulting in access.

FIG. 19 depicts an example of validation key trajectory resulting in authorization failure.

DETAILED DESCRIPTION OF THE INVENTION

FIG. 1 is a block diagram of a desktop computer 100 which comprises a CPU 102; storage 103, which comprises memory 104 and optionally one or more devices with retention medium(s) 105 such as hard disks, diskettes, compact disks, or tape; an optional display device 101; and one or more input devices 106, examples of which include but are not exclusive to: a keyboard 108; one or more pointing devices 107, such as a mouse; or a biometric device 109, such as a fingerprint reader. The mouse is the most popular pointing device 107 for desktop computers 100. In the description below, mention of a mouse is meant to include pointing devices 107 of any type, including, for example, a pen or stylus used in computing devices where a user may "write" upon a screen. The described software may be employed on such a computer 100. As well, the software described may find application in other computer-like devices requiring secured access, including hand-held or embedded devices.

In the following description, software-determined protocol includes exemplary methods or techniques such as algorithms; or non-algorithmic methods or techniques, including, for example, fuzzy logic or neural network pattern matching; or, random or pseudo-random determinations. A random or pseudo-random technique that results in seemingly arbitrary selection, the equivalent of software rolling dice, is referred to as non-deterministic.

In the following description, protocols, algorithm types, data types, and types of data, such as transmission 11, signal 21, packaging 13, sequencing 15, or encryption 14 types or protocols, are identifiable using binary identification codes (type identifiers), by data length, or other data signature, such

as a uniquely identifiable bit pattern, or by convention, such as known location (offset) within a data structure.

FIG. 2 depicts the access authentication process 97, comprising submission 9, validation 18, and authorization 27. Naturally, an account 109 must be created 10 before any access authentication process 97 may occur.

Submission 9 comprises one or more transmissions 1 intended for authenticating access to a computer 100 or network of computers 100. As depicted in FIG. 3, in one embodiment, a submission 9 comprises identification 3 and signature 4. Historically, an account name would be an identification 3, and a password a signature 4. If surety of uniqueness may be assured, in an alternate embodiment, a submission 9 comprises a single signature 4s, as depicted in FIG. 4, supplanting separate identification 3 & signature 4a while providing for the dual components of identification 3 and signature 4. With submission 9 solely comprising signature 4s, an account 109 may be identified by the signature 4s data itself, or by having an account identifier 109 embedded within a key 6 that has been accessed during validation 18 of the signature 4s.

A transmission 1 is user input into the computer 100 via one or more input devices 106, whereupon termination of transmission 1 is recognizable, and resulting in at least one signal 2. There may be different types 11 of transmissions 1, examples of which include mouse 107 movements or clicks, keyboard 108 entry, or combinations thereof. Other types 11 of transmissions 1 are possible with different input devices 106, such as, for example, voice transmission 1 if the computer 100 is equipped with a microphone and speakers.

Multiple-device 106 transmission 1m is conceivable. An example of a multiple-device 106 transmission 1 is a combination of mouse 107 movement while one or more keys 108 are pressed, as depicted in FIG. 6.

A signal 2 is a set of related software-recognizable data from a single transmission 1. A plurality of signals 2 of different types 21 may emanate from a single transmission 1. For example, typing a word may yield the signals 2 of entered keys 210 and the timing between keystrokes 211. Another example: mouse 107 movement of the cursor may yield signals 2 of locations 214, velocities, duration, and shape pattern (s) (such as script signatures, drawn characters, and so on) 215.

A transmission 1 of composite signals 2C comprising a plurality of simple signals 2S is conceivable. For example, a multiple-device 106 transmission 1m produces a composite signal 2C if matching to signals 2 of both devices 106 is required, as does requiring signal match 5 of multiple signal types 21 from a single-device transmission 1.

Signal data 22 may be categorized by its transmission type 11 and/or signal type 21, as depicted in FIG. 5. For easy identification, each possible transmission type 11 or signal type 21 may be assigned a unique ordinal. Hypothetically, if a multiple-device 106 transmission 1 is identified as a unique transmission type 11, the range of transmission types 11 may extend to the factorial of all possible input devices 106, depending upon the embodiment employed. To avoid unnecessary complication, consider signal type 21 as potentially additive (rather than combinatorial): for example, a key-mouse transmission 1 could be considered as comprising key 108 plus mouse 107 signals 2, rather than some uniquely identifiable key-mouse signal type 21.

Identification 3 is at least one transmission 1 of an account identifier 109. Historically, identification 3 has been a keyed-in account name 109. Employing the invention, identification 3 comprises at least one signal 2 from at least one transmission 1. A translation table, algorithmic method, or other software-determined protocol, with or without encryption 14,

may be employed if identification 3 or signature 4s does not represent the actual account identifier 109.

A signature 4 is at least one transmission 1 intended as a security precaution to preclude unauthorized access 39. Historically, a single signal 2 of a single transmission 1 has typically been used for a signature 4, namely a password, which is a signature 4 of a single word of text. A pass-phrase is a signature 4 of a plurality of words of text.

A plurality of transmissions 1 or signals 2 may be used for identification 3 or signature 4. In some embodiments, a user may determine the transmission(s) 1, signal(s) 2, transmission type(s) 11, or signal type(s) 21 that comprise a submission 9. Alternately, transmission 1 or signal 2 determination accords with a software-determined protocol.

Historically, validation 18 has required an absolute signal match 5 to input 22: for example, no deviance from a character-based password has been permitted. With mouse 107 movements, or other difficult-to-exactly-replicate signals 2, however, some tolerance may be permitted. Signal 22 tolerance should be allowed when appropriate, and may be set by software-determined protocol or user selection. For example, deviance up to 10% from recorded signal match 5 for keystroke timing 211 may be acceptable. Similarly, as another example, mouse click location may vary within a radius of 10 pixels and still be tolerated. As multiple signals 2 may comprise a submission 9, the need for exactness for any single signal 2 to properly authenticate access 97 is lessened.

Termination of submission 9 may be active or passive. FIGS. 7 & 8 illustrate. Inputting a password or pass-phrase, for example, is typically terminated by pressing the 'Enter' key or clicking an equivalent acknowledge button 43 using the mouse 107. As another example, inputting mouse 107 movement may be actively terminated by a mouse 107 click. With active termination 78, a user terminates submission 9 through a prescribed indication 25. With passive termination 77, software terminates submission 9 without overt user action, but instead when a predetermined condition is met 26. Examples of passive termination 77 include: recording mouse 107 movement or sound for a limited time, or until a certain elapsed time absent further input; until sufficient signal 2 has been input to allow a signal match 5; or until a succeeding transmission 1 of another transmission type 11 or signal type 21 commences, the change of type 11 itself indicative of previous transmission 1 termination. For example, changing from cursor/mouse movement to mouse button clicking may be considered a change in signal type 21, and hence a possible basis for passive termination. Biometric transmission 1 is typically passively terminated 77: software terminates submission 9 when sufficient biometric signals 2 have been recorded.

Termination 23 of identification 3 or signature 4 may occur using any number of protocols: passively 77 by a predetermined or user-selected number of transmissions 1; final transmission 1 by a particular type of action; active termination 78 by a final gesture, such a key or button press; passive termination 77 by time out of a predetermined duration or sufficiency of data collection. Another example: incremental validation 181 permits passive termination 77 via absence of next key trajectory 7, or, alternately, completed signal matching 5 of all relevant keys 6.

FIGS. 9 & 10 depict an example account input 99 or post-account 109 creation submission 9 screen 40, employed to input at least a signature 4. (In one embodiment, account identifiers 3 may be assigned.) Text transmission(s) 1 can be input in the text input dialog 41 comprising a text input control 42 and acknowledge button 43. Signature 4 transmission(s) 1 can be input, and input signals 2 recorded. FIG. 9

5

depicts dragging the text input dialog 41 down the screen 40 as a transmission 1 (by pressing the proper mouse 107 button when the cursor is over an appropriate section of dialog 41, thus selecting the dialog 41, then moving the mouse 107 while keeping the button pressed). The dragging action in this example is terminated by a mouse-up (releasing the mouse 107 button).

In one embodiment, a user may determine as part of account creation 99 which signal types 21 are to be considered for validation 18 of subsequent submissions 9. This is an editing process that may be construed as part of account input 99. For example, after submission termination 23, having recorded signals 2 for account input 99, as depicted in the example of FIG. 10, the user may select, via checkbox controls as shown, which signal types 21 of the transmission 1 depicted in FIG. 9 are to be considered for the transmission 1 being recorded. The checkboxes are specific to types of signals 21 appropriate to the type of transmission 11 employed. In the described example, the checkboxes (for signal type 21 selection) appear only for account input 99, not when a user is making an submission 9 after an account 109 has been created, as the prerequisite signals 2 for signature 4 or identification 3 have already been stored.

FIG. 9 depicts a button 25 for submission termination 78. A termination button 25 or its equivalent is necessary only with active termination 78. Initial input for account creation 10 may use active termination 78 which is later edited out during a subsequent signal 2 and transmission 1 selection process, resulting in passive termination 77.

There is an embodiment whereby a user may determine some or all of the transmissions 1 or transmission types 11 comprising account input 99. There is an embodiment whereby a user may determine which signal types 21 of select transmissions 1 comprise account input 99. Otherwise, software-determined protocol may determine all or some transmissions 1 or signals 2 comprising account input 99.

In one embodiment, account input 99 captures all transmission 1 signals 2 until actively terminated 78. In an alternate embodiment, account input 99 may be passively terminated 77. In one embodiment, transmissions 1 and signals 2 from account input 99 may be edited, the user selecting signals 2 and termination, such that only select, edited signals 2 and termination types are employed as account submission 9. In alternate embodiments, as aspects of account input 99, signals 2 may not be edited or user-selected, or termination 23 type user-determined.

FIG. 11 depicts account creation 10, in the beginning of which account input 99 provides one or more signals 2 from one or more transmissions 1 for packaging into one or more keys 6. Each user account 109 has at least one key 6 for access authentication 97.

There are two aspects to account creation 10: packaging 13, and key 6 creation or employment 16.

Packaging 13 tells how to interpret keys 6, including stored match signals 5. Overt packaging 13 is optional, and may vary by embodiment. Packaging 13 may be implicit by software-determined protocol, obviating the need for overt, data-based packaging 13. There may be two optional aspects to packaging 13: encryption 14 and signal sequencing 15.

Encryption 14 refers to encrypting or decrypting all or part of key 6 data. Encryption 14 is optional, but recommended. Encryption 14 employment may vary by embodiment. In one embodiment, the same encryption 14 protocol or algorithm is used throughout (thus, predetermined). In alternative embodiments, encryption 14 may vary by software-determined protocol or by user selection on a per-user or per-signal

6

2 basis. If a plurality of protocols are used for encryption 14, the protocol 14 employed must be identifiable.

As a suggestion for encryption 14, initial input signals 2 in the first transmission 1 may comprise a parametric seed for encrypting one or more keys 6. Caution is advised if non-exact signal matching 5 is tolerated, as close may not good be enough for decryption using such a seed technique, but it is possible to incorporate tolerance into an encryption 14 algorithm, so that an acceptable margin of error for signal matching 5 may also suffice for decryption as well. Mathematical rounding is a suggested technique allowing such tolerance; as well employing a subset of possible signals 2, such as a high and low, or using one or more algorithmically-derived values, such as median or mean.

Signal sequencing 15 is codification of the order of signals 2. Signal sequencing 15 may be predetermined (software-determined), such as, for example, input order, or, alternately, a predetermined prioritization. In alternative embodiments, signal sequencing 15 may vary by software-determined protocol or by user selection. If a plurality of protocols are used for signal sequencing 15, the protocol employed must be identifiable.

Sequencing 15 and encryption 14 may be combined, offering further opportunity for obscuring decipherment of packaging 13 protocols.

During account creation 10, each selected signal 2 is optionally encrypted 14, encoded for subsequent signal matching 5, and stored in keys 6, which are stored in key files 8, for subsequent access authentications 97.

As in the prior art, each account 109 must be unique. For accounts 109 where submission 9 comprises identification 3 and signature 4A, identification 3 must be unique. For accounts where submission 9 comprises signature 4s, the signature 4s itself must be unique. During account creation 10, this can be verified by attempting to validate 18 the appropriate component of a submission 9 for a new account 109 prior to establishing the account 10.

A key 6 may contain account 109 identification 3.

As depicted in FIG. 11, a key unit 16 is a virtual or actual collection of signal matches 5. As in one embodiment a single key 6 may have a plurality of signal matches 5, and thereby function as a plurality of keys 5 in alternate embodiments, a key 6 may comprise a key unit 16. A key file 8 as an actual or potential collection of keys 6 a key unit 8. An established account 109 may be considered a virtual aggregation of the keys 6 used to validate 18 submission 9 for that account 109, hence also represents a key unit 16.

A key file 8 comprises at least one key 6. A key file 8 may comprise a plurality of keys 6, or what deceptively may be keys 6: a key file 8 may have pseudo-keys as key file 8 filler. In one embodiment, key files 8 may be a uniform number of bytes, regardless of the number of keys 6 stored in a key file 8. Keys 6 may be in files 8 not exclusively comprising keys 6 (or pseudo-keys); in other words, a key file 8 may as well be employed for other purposes, including files 8 comprising unrelated data or even executable code.

As depicted in FIG. 12, a key 6 may comprise packaging 13, at least one signal match 5 facility, and at least one next key trajectory 7. In alternate embodiments, key 6 composition varies; the minimum requirement is that a key 6 comprises at least one signal match 5. Packaging 13 and next key trajectory 7 inherency may vary.

A signal match 5 is a signal 2 stored in a key 6 during account creation 10, used for validation 18 of a subsequent submission 9 signal 2. A key 6 may comprise a plurality of signal matches 5.

A next key trajectory 7 vectors validation 18 to the next key 6, or, if the terminal key 6_t, results in forwarding match results 33 for authorization 27, by absence of next key trajectory 7 in one embodiment. Next key trajectories 7 are a sequential organizational facility for keys 6.

Next key trajectories 7 may be obviated by having a single key 6 with sufficient contiguous signal matches 5 for validation 18, whereupon the signal matches 5 within the key 6 are sequenced, organized, indexed, or otherwise knowable by software-determined protocol in relation to packaging 13.

As the correspondence of signal match 5 to key 6 varies by embodiment, so too where a next key trajectory 7 leads. Depending upon restrictions that may be imposed in an embodiment, a next key trajectory 7 may lead to a key 6 in the same key file 8 as the last key 6, a key 6 in another key file 8, or the same key 6 if the key 6 holds a plurality of signal matches 5.

Next key trajectory 7 provides all or part of a reference to the next key 6 used in validation 18, if there is a next key 6. A next key trajectory 7 may be encrypted 14.

A next key trajectory 7 may be combined with other data that may have been or need to be mathematically transposed to determine the next key 6. For example, all or a portion of an account 109 identifier 3, part of a signal match 5, or some portion of packaging 13 may be combined with the next key trajectory 7 as a next key 6 identifier. Next key trajectory 7 may comprise or reference an offset in a key file 8. A next key trajectory 7 may reference a key index entry 62.

A key 6 may include a plurality of next key trajectories 7, in which case a different next key trajectory 7 may be selected based upon signal match 5 results—one or more next key trajectories 7 for a correct signal match 5, likewise for an wrong signal match 5. With a plurality of next key trajectories 7, a next key trajectory 7 may be selected based upon signal match 5 results, or by software-determined protocol, or a combination thereof.

Packaging 15 may be encoded as part of the next key trajectory 7. For example, a next key trajectory 7 may include the signal sequencing 15 that identifies next signal match 5 type 21. In this instance, if the next input signal 2 cannot be of the same type 21 as the next signal match 5, authorization 27 may fail 86. Knowing that at that point, a wrong trajectory protocol 7_w may be invoked to avoid identifying a proper key unit 16.

A submission 9 comprising identification 3 followed by signature 4_a is easier to validate 18 than a submission 9 solely comprising signature 4_s: knowing an account identifier 3 provides the means to know what the signature 4_a should be.

Historically, identification 3 has not been relied upon for security. Signature 4 has played gate-keeper to unauthorized access 39, not account identification 3.

An initial key 6_i that may ultimately lead to authorized 27 access 39 must associate to an account 109, either directly or by reference. There may be keys 6 for which authorization 27 cannot succeed 86 that may not associate to an account 109 for which access 39 may be obtained. A key unit 16 for which authorized 27 access 39 is unobtainable is referred to as a fake key 6_w.

Organize key units 16 as an optimization. Various conventions of organizing or indexing accounts 109, keys 6, and key files 8 may be employed. In alternate embodiments, the same organizing principles may be applied at the level of key 6, key file 8, or account 109.

Optimally, keys 6 are organized to facilitate rapid search for signal matches 5, particularly for finding initial signals 2_i when submission 9 solely comprises signature 4_s. Keys 6 may

be sorted. For example, keys 6 for initial signals 2_i may be arranged in binary sorted order by signal type 21 and signal 2.

Key files 8 may be organized by account 109, or by transmission type 11. Key files 8 may be organized by signal type 21, with keys 6 within files 8 organized by input ordinal. Alternately, an initial key file 8_i may comprise all possible initial keys 6_i (of first signal matches 5), possibly organized or indexed by signal type 21. One or more key files 8 may contain one or more indexes 61 to keys 6 within their respective files 8.

A key file 8 may include an index, or key files 8 themselves be indexed. The next key trajectory 7 may provide next key 6 lookup via an index 61. A key file 8 may include an index 61_i to initial signal keys 6_i. The index 61 may comprise key trajectories 7, including key trajectories 7 to possible first keys 6_i, which may be organized by transmission type 11 and/or signal type 21.

FIG. 14 depicts an example of key 6 indexing. Key 6 indexing 61 or organization is recommended when submission solely comprises signature 4_s where a user may input signals 2 in any user-determined manner. Depicted in FIG. 14 is a key file 801 with a key index 61, specifically an initial key index 611. The depicted initial key index 611 contains references to keys 6_i that contain at least initial signals 2.

In the FIG. 14 example, only initial keys 6_i are indexed. In this example, checking possible initial keys 6_i constitutes initial key trajectory 71. One or more next key trajectories 7 in an initial key 6_i may indicate keys 8 for succeeding signal matching 5, like links in a chain, so only an index of initial keys 6_i is required. Alternately, a single key 6 may contain all necessary signal matches 5 for validation 18.

A key index 61 may reference keys 6 in different files 8. As depicted in the FIG. 14 example, initial key index 611 entries 62 reference keys 6 of the same input signal type 21. Initial key code keys 210, for example, reference keys 6210 in the same file 801 as the index 611, while keystroke timing keys 6211 referenced by the keystroke timing index entry 211 reside in another key file 802. Key indexing 61 is an optimization.

A key code & mouse click key index entry 217 is depicted in FIG. 14 as an example of a composite signal 2. The key code & mouse click key index entry 217 may reference keys 6 comprising multiple signal matches 5, one for each simple signal 2 (key code 210 and mouse click 212), or, alternately, reference multiple keys 6, each with simple signal matches 5 that altogether comprise the composite signal 2.

Without key file 8 organization or key indexing 61, more keys 6 may need to be considered than just those keys 6_i for initial signal matches 5. With next key trajectories 7 referring to subsequent keys 6, optimally, only potential initial keys 6_i need be searched to commence validation 18.

FIG. 15 depicts post-submission validation 180: input signals 2 are accumulated 47 and submission 9 completed 46 before validation 18 commences. FIG. 16 depicts incremental validation 181: validation 18 is concurrent with submission 9 transmission 1. In other words, with incremental validation 181, validation 18 may progress with each signal 2 or transmission 1.

Submission termination 23 must be known using post-submission validation 180. This is a potential drawback: unless software-determined protocol determines submission termination 23, passive termination 77 cannot be accomplished using post-submission validation 180; active termination 78 must be used. For full user-determined submission 9, employ incremental validation 181, which has the con-

comitant advantage of immediate knowledge of authorization failure **86**, allowing wrong key trajectory 7_w protocol interposing.

FIG. **17** depicts the validation **18** process, which is similar regardless whether post-submission validation **180** or incremental validation **181** is employed.

Incremental validation **181** may commence once the first transmission **1** completes, or, in a more sophisticated embodiment, ongoing **88** with signal input **2**. In a concurrent validation **181** embodiment, initial signal keys may be accumulated **50** and subsequent unmatched keys discarded **51** concurrent with transmission **1**, on a signal-by-signal **2** basis.

Validation **18** commences by accumulating possible keys **55** based upon signal match **54** between signals **2** of the first transmission **1** and possible initial signal keys **52**. For subsequent transmissions **1**, accumulated keys are discarded **59** by failure to match signals **57**. Match results **33** are passed to authorization **27** when there are no keys remaining **73** or no next key trajectories **7** for remaining keys **75**. As long as there are remaining keys **34** with next key trajectories **74**, the process of discarding keys that don't match **51** continues **818**.

FIGS. **18** & **19** depict examples of the access authentication **97** process. FIGS. **18** & **19** illustrate an example of one-to-one correspondence between signal match **5** and key **6**. Through access to one or more keys **6** which may reside in one or more key files **8**, validation **18** produces signal match results **33**, upon which authorization **27** permits access **29**, allows retry **28** of submission **9**, or denies access **27**.

Full submission **9** comprises a set of signals **2** upon which access **39** may be granted **72**. Incomplete submission **9** comprises a set of signals **2** to which additional user input is ongoing **88**, and for which by themselves **2** authorization **27** would not succeed **86**.

In an example depicted by FIG. **18**, the first trajectory **71** is to a key **6i** in a key file **8i** determined by signal type **21**. Keep in mind that this process may be repeated for all possible initial keys **6i**. For example, consider key **108** transmission **1** input **2**, with two possible corresponding signals **2**: key (character) codes **210**, and timing of key strokes (rhythm) **211**. As an example, a key unit **16** of key code signal type **21** might be accessed to search keys **6** for signal matches **5** of key code **210** signals **2**. It may be, for example, that user-selected signal selection was employed, with initial key code **210** signals **2** for the first input to be ignored, and key rhythm **211** used. A key code **210** match **5** may be found, but it would be wrong in this example, though with incremental signal matching **5**, this would not be known at first. A key unit **8** of key rhythm **211** signal types **21** would also find a match **5** after the second key code (as rhythm is the timing between successive keystrokes), this time (in this example) for the correct user. In this example, the key **6** with rhythm **211** signal match **5** may have sequence packaging **15** indicating that key code **210** is ignored for this transmission **1**. So, in this example of incremental validation **181**, initial signal input **2** has multiple signal matches **5**, narrowing possibilities in the initial transmission **1** to two possible accounts meriting validation **18** consideration. In this example, subsequent input signals **2** narrow validation **18** to a single account **109** by a sequential process of elimination.

So, with incremental validation **181** there may need to be a plurality of input signals **2** before signal match **5** may effectively commence. In the example above, where key rhythm **211** is the first signal **2** to be matched **5**, two key code **210** signals **2** must be input before key rhythm **211** may even be considered.

In the example of FIG. **18**, validation **18** accesses three key files **8** through successive key trajectories **7**, bundling match

results **33** for authorization **27**. In the depicted example, input signals **2** are validated **18** in input order interactively **88** with input **2**. In other words, validation **18** is incrementally contemporaneous **88** with submission **9**. In an alternate embodiment with alternate sequencing **15**, input signal **2** validation **18** may not commence until submission **9** is completed **46**. The described example facilitates rapid authorization **27** by incremental validation **18**. Actually, while access **39** may marginally be accelerated by incremental validation **18**, only lack is authorization **86** is notably rapidly facilitated, as continued input **2** of a submission **9** that cannot possibly be validated **18** may be interrupted so that a user may retry **63**.

FIG. **19** depicts an example of an embodiment employing a wrong trajectory protocol 7_w . Wrong trajectory protocol 7_w is employed as a means of obfuscation targeted at computer monitoring devices. In the depicted example, keys **6** are constructed with multiple key trajectories **7**, with at least one trajectory to a succeeding key **6** whereupon authorization **27** may succeed **72**, and at least one trajectory 7_w whereupon access **39** is hopeless (fake keys 6_w). In the example, signal match **77** in the initial key **77** in the initial key file **8i** mismatches. In this case, key trajectory 7_w leads to a fake key 6_w that cannot result in successful authorization **86**: whatever key **6** or key file **8** pinball is used, authorization fails **86**.

Trajectories **7** may be selected non-deterministically. This suggestion is most effective when there are multiple possible trajectories **7**, including wrong key trajectories 7_w , that augur either for authorization success **72** or failure **86**.

For example, a key **6** may contain six next key trajectories **7**, three of which are wrong key trajectories 7_w . Depending upon signal match **5** results, one of the three right or wrong trajectories **7** are non-deterministically chosen. This example presupposes sequences of keys **6** strung together by next key trajectories **7** that play out to authorization **27**. It is possible for different next key trajectories **7** to diverge to different (possibly duplicate) keys **6** that later converge back to the same key **6**.

As described, validation protocols **18** may vary, and different protocols may be combined. Multiple non-deterministic trajectory **7** paths, including wrong trajectory 7_w , is one example. In some embodiments, validation protocol **18** authorizing **27** access **39** may use different trajectories **7**. Duplicate signal matches **5** in different keys **6** in the same or different key files **8** may be employed to have various paths to authorization **27**. As another suggestion, different signal sequencing **15** may be employed to differ trajectories **7**.

The following is claimed:

1. A computer-implemented process comprising:

- receiving user indication of signature input recording;
- recording user input signals by type from at least one user-selected device among a plurality of selectable user input devices connected to a single computer, wherein a signal comprises a set of related software-recognizable data of the same type received from at least one input device,
- wherein a signal type comprises a category of measurable variable input associated with at least one user-selectable input device, and
- wherein at least one user-selectable input device affords recording a plurality of signal types;
- terminating said recording;
- storing at least a portion of said recording;
- creating a signature based at least in part upon at least a portion of said stored recording; and
- storing said signature.

2. The process according to claim **1**, wherein said recording comprises signals from a plurality of user-selected devices.

11

3. The process according to claim 1, further comprising:
 receiving user indication to edit said signature;
 receiving user selection of at least one signal type from a
 plurality of signal types associated with at least one user
 input device of said recording;
 editing said stored signature to exclude recorded data of at
 least one signal type.

4. The process according to claim 1, further comprising:
 comparing a subsequent signature submission to at least a
 portion of said recording,
 and accepting said comparison within a predetermined
 degree of inexactness,
 thereby authenticating said subsequent signature.

5. The process according to claim 4, wherein said prede-
 termined degree comprises a user-designated tolerance.

6. The process according to claim 1, further comprising
 presenting at least a portion of said recording to said user for
 editing,
 wherein said presented recording portion does not com-
 prise text-character codes.

7. The process according to claim 1, wherein at least a
 portion of said recording comprises at least one signal type
 comprising signal input from a plurality of devices.

8. The process according to claim 1, further comprising:
 dividing a stored signature into distinguishable data por-
 tions,
 wherein each said distinguishable data portion comprises a
 key;
 linking keys of a signature,
 said links determined at least in part by sequential order of
 user input corresponding to recorded signals;
 dividing a plurality of stored signatures into keys;
 receiving a first portion of user input data;
 accumulating keys of a plurality of signatures based upon
 matching stored key data to said first portion of user
 input data;
 subsequently, iteratively receiving a plurality of portions of
 user input data and performing a corresponding authen-
 tication step for each portion,
 wherein, upon receiving each subsequent portion after said
 first portion, discarding from further processing previ-
 ously accumulated keys based upon failure in matching
 respective key data to said user input data portion; and
 whereby continuing said iterative process until completing
 authentication by matching said last key to correspond-
 ing said user input data portion, or by process of elimi-
 nation determining authentication impossible.

9. The process according to claim 1, wherein said signature
 comprises signals from at least one category determined by
 received input after said storing at least a portion of said
 recording.

10. A computer-implemented process comprising:
 commencing signature input recording;
 recording user input signals by type from at least one
 user-selected device among a plurality of selectable user
 input devices connected to a single computer,
 wherein a signal comprises a set of related software-rec-
 ognizable data of the same type received from at least
 one input device,
 wherein a signal type comprises a category of measurable
 variable input associated with at least one user-select-
 able input device, and
 wherein at least one user-selectable input device affords
 recording a plurality of signal types;
 terminating said recording;
 storing at least a portion of said recording;

12

creating a signature using said stored recorded user input
 signals from a plurality of categories of measurable vari-
 able input; and
 storing said signature.

11. The process according to claim 10, wherein said sig-
 nature comprises signals from at least one signal type deter-
 mined by received input after said storing at least a portion of
 said recording.

12. The process according to claim 10, wherein passively
 terminating said recording.

13. The process according to claim 10, further comprising:
 dividing a stored signature into distinct data portions;
 recording and storing a second series of user input signals
 after storing said signature,
 wherein said second series of user input signals are
 received in incremental portions;
 comparing at least one said distinct data portion to at least
 one said incremental portion;
 storing said comparison; and
 determining whether to continue receiving and storing a
 succeeding incremental portion based upon said compar-
 ison.

14. The process according to claim 10, further comprising:
 comparing a subsequent signature submission to at least a
 portion of said recording,
 and accepting said comparison within a predetermined
 degree of inexactness,
 thereby authenticating said subsequent signature.

15. A computer-implemented method for recording input
 and creating a signature comprising:
 recording user input signals by type from at least one
 user-selected device among a plurality of selectable user
 input devices connected to a single computer,
 wherein a signal comprises a set of related software-rec-
 ognizable data of the same type received from at least
 one input device,
 wherein a signal type comprises distinct measurable vari-
 able input associated with at least one user-selectable
 input device, and
 wherein recording a plurality of signal types for at least one
 user-selected device;
 terminating said recording;
 storing at least a portion of said recording;
 creating a signature based at least in part upon at least a
 portion of said stored recording; and
 storing said signature.

16. The method according to claim 15, wherein said sig-
 nature comprises signals from at least one signal type deter-
 mined by received input after said storing at least a portion of
 said recording.

17. The method according to claim 15, wherein creating
 said signature using recorded signals from a plurality of sig-
 nal types.

18. The method according to claim 15, further comprising:
 dividing a stored signature into distinct data portions; and
 incrementally authenticating a second series of user input
 signals to said signature by comparing said second series
 of user input signals to their respective distinct data
 portions of said stored signature.

19. The method according to claim 15, wherein creating
 said signature from input signals from a plurality of user-
 selected input devices.

20. The method according to claim 15, wherein said sig-
 nature comprises in part signals from a pointing device.