

IN THE UNITED STATES DISTRICT COURT
FOR THE WESTERN DISTRICT OF WISCONSIN

DOUGLAS DYNAMICS, LLC,

Plaintiff,

v.

BUYERS PRODUCTS COMPANY,

Defendant.

SUMMARY JUDGMENT
OPINION AND ORDER
ON INVALIDITY

09-cv-261-wmc

This patent infringement action involves five patents related to the mounting of snowplows, as well as the hydraulic and electrical systems on snowplow assemblies. Plaintiff Douglas Dynamics, LLC alleges that defendant Buyers Products Company sells snowplow assemblies that infringe claims in all five patents. The court has already completed its claims construction and infringement analysis with respect to all of the patents-in-suit. (*See* Court Infringement & Noninfringement Opinion, dkt. #332.) This opinion and order takes up the parties' arguments on invalidity. Specifically, Douglas moves for summary judgment on Buyers' counterclaims that Douglas's United States patents nos. 5,420,480 (the '480 patent), Re. 35,700 (the '700 patent) and 6,944,978 (the '978 patent) are invalid. Buyers cross-moves for summary judgment on its invalidity defenses and counterclaims with respect to both the '700 patent and the '978 patent, and seeks summary judgment on its invalidity counterclaim with respect to Douglas's United States patent no. 5,353,530 (the '530 patent).

With respect to the '978 patent, the court will grant Douglas's motion and deny Buyers' because (1) no single piece of prior art offered by Buyers anticipates the asserted

claims of that patent and (2) no combination of multiple pieces of prior art offered by Buyers would have made those claims obvious. With respect to the '530 patent, Buyers' motion will be denied because genuine issues of material fact remain with respect to invalidity. As far as the '480 patent is concerned, Douglas's motion will be granted and Buyers' denied because Buyers failed to provide any evidence to support its invalidity counterclaim. Finally, the court will exercise its discretion and deny both Douglas's and Buyers' motions with respect to the '700 patent in light of its earlier finding that Buyers' snowplow assemblies do not infringe any of the asserted claims of the '700 patent, dismissing Buyers' invalidity counterclaim without prejudice in the interest of efficiency.

OPINION

I. Relevant Law

Under 35 U.S.C. § 282, issued patents are presumed valid. “[A] moving party seeking to invalidate a patent at summary judgment must submit such clear and convincing evidence of facts underlying invalidity that no reasonable jury could find otherwise.” *TriMed, Inc. v. Stryker Corp.*, 608 F.3d 1333, 1340 (Fed. Cir. 2010) (internal quotation omitted). Conversely, if the moving party is seeking a ruling that a patent is not invalid, it would be successful at summary judgment if no reasonable jury could find that the patent was anticipated or made obvious by the prior art.

A. Anticipation

“Invalidity by anticipation requires that the four corners of a single prior art document describe every element of the claimed invention, either expressly or inherently.” *TriMed, Inc.*, 608 F.3d 1343 (internal alterations and quotations omitted); *see also* 35 U.S.C. § 102. In other words, “[t]here must be no difference between the claimed invention and the reference disclosure, as viewed by a person of ordinary skill in the field of the invention.” *Scripps Clinic & Research Found. v. Genentech, Inc.*, 927 F.2d 1565, 1576 (Fed. Cir. 1991) *overruled on other grounds by Abbott Lab. v. Sandoz, Inc.*, 556 F.3d 1282 (Fed. Cir. 2009). Determining whether a prior art reference anticipates a patent claim is a question of fact. *TriMed, Inc.*, 608 F.3d at 1343.

B. Obviousness

Even if no single piece of prior art anticipates the claimed invention, a patent’s claims may be invalid “if the differences between the subject matter sought to be patented and the prior art are such that the subject matter as a whole would have been obvious at the time the invention was made to a person having ordinary skill in the art to which said subject matter pertains.” 35 U.S.C. § 103(a). The ultimate decision on obviousness is a question of law. *KSR Int’l Co. v. Teleflex Inc.*, 550 U.S. 398, 427 (2007). Making this determination requires consideration of several relevant factual inquiries, including: “(1) the scope and content of the prior art; (2) the differences between the claimed invention and the prior art; (3) the level of ordinary skill in the art; and (4) any relevant secondary considerations.” *TriMed, Inc.*, 608 F.3d at 1341. When “the content of the prior art, the scope of the patent claim, and the level of ordinary skill in the art are

not in material dispute, and the obviousness of the claim is apparent in light of these factors, summary judgment is appropriate.” *KSR Int’l Co.*, 550 U.S. at 427.

In deciding obviousness, “a patent composed of several elements is not proved obvious merely by demonstrating that each of its elements was, independently, known in the prior art.” *Id.* at 418. This is because “it can be important to identify a reason that would have prompted a person of ordinary skill in the relevant field to combine the elements in the way the claimed new invention does.” *Id.* Identification of this reason often involves the use of what is referred to as the “teaching, suggestion or motivation test.” *Id.* While application of this test is permissible, it is not “a rigid rule that limits the obviousness inquiry.” *Id.*

II. The ‘978 Patent

A. Anticipation

Buyers contends that claims 28, 35, 57, 58 and 59 are anticipated by United States patent no. 5,485,690 (“the MacQueen patent”). There is no dispute that the MacQueen patent is prior art. In fact, the original claims submitted to the Patent and Trademark Office in the application that would become the ‘978 patent were rejected as anticipated by the MacQueen patent. (Prosecution History of ‘978 pat., dkt. #42, at DD00754-756.) The inventors proceeded to amend the claim language to overcome the prior art and the PTO accepted the change as sufficient to put the claims outside the scope of the MacQueen patent. Having been clearly considered by the PTO before the ‘978 patent was issued, Buyers’ burden in proving anticipation using the MacQueen

patent “becomes particularly heavy.” *Impax Lab., Inc. v. Aventis Pharm., Inc.*, 545 F.3d 1312, 1314 (Fed Cir. 2008).

After initially rejecting the claims of ‘978 patent as anticipated by the MacQueen patent, the examiner allowed the claims after the inventors changed the relevant claim language as follows: “said first and second receivers receiving said first and second arms, respectively upon relative longitudinal movement there between in a direction generally parallel to the longitudinal axis of the vehicle.” (Prosecution History of ‘978 pat., dkt. #42, at DD000764.) Buyers argues that the examiner’s determination that the amended claim language was no longer anticipated by the MacQueen patent is “simply incorrect.” (Def.’s Br., dkt. #167, at 52.)

Specifically, Buyers contends that in MacQueen the pipe 72 moves in a longitudinal direction to be received by receivers 94, as seen in figure 20 of the MacQueen patent:

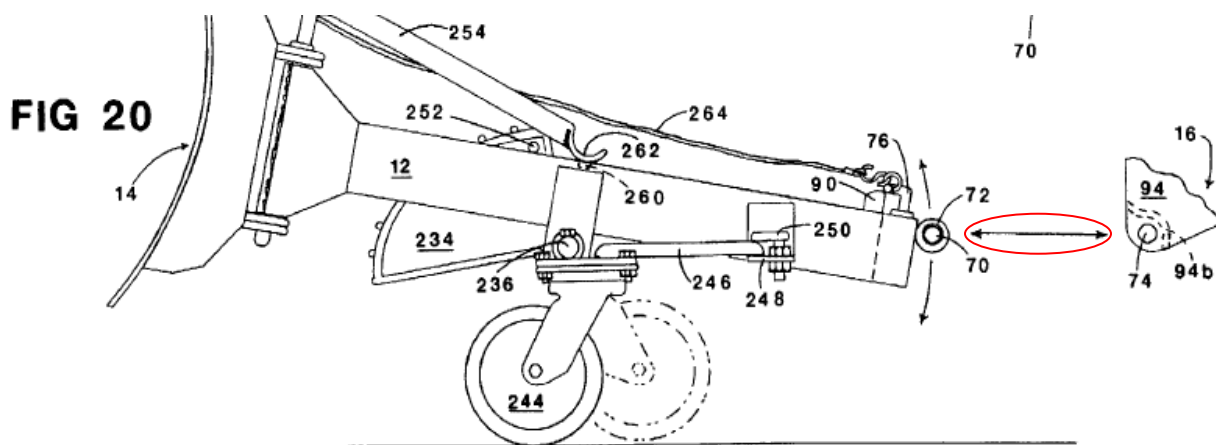

‘690 pat., Figure 20 (emphasis added). There is no denying that the entire pipe -- as well as the entire plow assembly for that matter -- moves in a direction parallel to the longitudinal axis of the vehicle to connect the plow assembly to the vehicle as evidenced

by the circled arrow in Figure 20. This movement, however, is not the specific movement addressed in claim 28 or any of the asserted claims of the '978 patent.

The relevant claim language requires: "said first and second receivers receiving said first and second arms, respectively upon relative movement therebetween in a direction generally parallel to the longitudinal axis of the vehicle." '978 pat., col. 10, lns. 18-21. "Movement therebetween" refers to movement between the arms and the receivers. In other words, movement of the arms or receivers in a direction parallel to the vehicle's longitudinal axis results in the receivers receiving the arms. Thus, there are two important limitations: (1) receiving of the arms by the receivers; and (2) the receiving being a result of movement between the arms and receivers in a direction generally parallel to the longitudinal axis of the vehicle.

The patent examiner, as well as Buyers, labeled the outer ends of the "pipe 72" and the "vertical plane surfaces 94 & 94" in MacQueen as "arms" and "receivers" respectively.¹ The inventors of the '978 patent explained to the patent examiner that their invention was different than that taught by MacQueen because in MacQueen the outer ends of the pipe (the arms) were received by the vertical plane surfaces (the receivers) upon movement in a direction lateral or transverse to the longitudinal axis of the vehicle. Put another way, the receivers in MacQueen do not receive the arms until movement in a direction transverse to the longitudinal axis of the vehicle.

¹ Douglas also disputes that the ends of the pipe can serve as arms or that the vertical plane surfaces can serve as receivers. There is no need to address those issues, however, since the '978 patent is not invalid as anticipated by the MacQueen patent for the reasons discussed above.

The patent examiner did *not* reject this limitation, but merely rejected the argument that the proposed claim language contained the limitation. (Prosecution History of '978 pat., dkt. #42, at DD000756 (“Applicant argues that the outer ends of MacQueen’s pipe 72 are ‘received’ upon lateral, i.e. transverse relative movement there between and not upon relative longitudinal movement as claimed. Applicant’s arguments however are more limiting than the claims themselves.”)) When the inventors amended the relevant claim language to make clear that receiving occurs by movement in a direction generally parallel to the longitudinal axis of the vehicle, the examiner accepted the claims as properly limiting the direction of movement for receiving.

This key difference between the '978 patent and the MacQueen patent is further supported by the examiners statement that “the longitudinal movement is not specifically defined in the claims. . . . [T]he pipe 72 has a longitudinal axis, and when *actuated* moves in the longitudinal direction of the pipe 72 itself.” (Prosecution History of '978 pat., dkt. #42, at DD00756. (Emphasis added).) The examiner was explaining that when the pipe is actuated, resulting in exposure of the pins **70** & **70** from the outer ends of the pipe, the movement of the pins is in the direction of the longitudinal axis of the pipe, which is also a direction transverse to the longitudinal axis of the vehicle. The examiner, therefore, wanted the inventors to clarify the direction of movement necessary for the receivers to receive the arms. The inventors provided the required clarification and the claims were accepted.

The specification of the MacQueen patent confirms this important difference between what the '978 patent claims and MacQueen teaches: the direction of movement

necessary for receiving of arms by the receivers. The specification in MacQueen teaches that the lever arm that keeps the pins retracted inside the pipe can be released, in turn releasing the pins, when the pipe is near the receiving holes in the vertical plane surfaces on the mounting frame. '690 pat., col. 8, lns. 55-60. Once released, the pins move in a direction transverse to the longitudinal axis of the vehicle and come in contact with the vertical plane surfaces creating enough force "to hold the entire rear portion of the plow frame 12 temporarily in place even if no lifting assistance . . . is used." *Id.*, col. 8, lns. 64-65. In other words, the vertical plane surfaces do not receive the pipe ends until the pipe's pins move or extend in a direction transverse to the vehicle's longitudinal axis. Putting this teaching in terms of the '978 patent: the receivers do not receive the arms until the arms extend or move in a direction transverse to the vehicle's longitudinal axis. This is not what claim 28, or any of the other asserted independent claims of the '978 patent, teaches.

Buyers points out that "[w]hat is important is the *direction of the movement* that is effected between the receivers and the arms" (Def.'s Br., dkt. #167, at 39 (emphasis in original), which is partially correct. What is important is the direction of the movement effected between the receivers and the arms *when the receivers receive the arms*. The '978 patent requires that direction to be "generally parallel to the longitudinal axis of the vehicle." The MacQueen patent teaches movement between the receivers and arms in the opposite direction. Under MacQueen the entire pipe along with the snowplow frame is moved generally parallel to the longitudinal axis of the vehicle, but the vertical plane surfaces (receivers) do not *receive* the pipe ends (arms) upon that movement. No

receiving is done until movement occurs in a direction transverse to the longitudinal axis of the vehicle.

Buyers, therefore, fails to satisfy its heavy burden of proving by clear and convincing evidence that the MacQueen patent -- a piece of prior art the examiner specifically considered and rejected as a basis for challenging the validity of the patent during prosecution -- in fact anticipates every element in claims 28, 35, 57, 58 and 59. No reasonable jury could find that it satisfies that burden.² There is a core difference between the MacQueen patent and the '978 patent in their teachings about the direction of the movement necessary to effectuate receiving of arms by receivers and no reasonable

² Douglas challenges the admissibility of the expert report submitted by Buyers' expert, Dr. Prah, because Prah did not swear under oath to the contents of the report. It is true that unsworn statements are not admissible evidence under Fed. R. Civ. P. 56(e). *See Steinle v. Warren*, 765 F.2d 95, 100 (7th Cir. 1985) (unsigned and unsworn copy of statement not admissible evidence at summary judgment). *See also* 10B Charles Alan Wright, Arthur R. Miller & Mary Kay Kane, *Federal Practice and Procedure* § 2738 n.42 (3d ed. 1998) (“[O]nly unsworn affidavits will be rejected.”). In response to this issue, Buyers submitted a declaration from Prah, swearing under penalty of perjury to the veracity of the contents of his expert report. (Tucker Decl., dkt. #209, ex. A.) Prah's declaration cures the inadmissibility problem. Because Douglas was not prejudiced by the late submission of the declaration -- it addressed the contents of the report regardless of its unsworn status -- the opinions in Prah's report are considered by this court in addressing the parties' motions regarding invalidity.

Buyers' expert, Dr. Prah, offers mere conclusory statements about the direction of movement taught in the MacQueen patent, citing nothing more than the language in the MacQueen patent without explaining why the difference between what is taught by that patent and what is claimed by the '978 patent as found by the patent examiner or Douglas's expert is wrong. Such conclusory opinions are unhelpful and do not provide evidence sufficient to withstand summary judgment. *See, e.g., Schumer v. Lab. Computer Sys., Inc.*, 308 F.3d 1304, 1315-16 (Fed. Cir. 2002) (conclusory testimony as opposed to a detailed explanation on how each claim element is disclosed in prior art reference is not sufficient to prove anticipation). *See also Dynacore Holdings Corp. v. U.S. Philips Corp.*, 363 F.3d 1263, 1277-78 (Fed. Cir. 2004) (framing expert's unsupported conclusion as assertion that critical claim limitation is found in accused device insufficient to raise genuine issue of material fact).

jury could find otherwise. Accordingly, the MacQueen patent does not anticipate claims 28, 35, 57, 58 and 59 the '978 patent and Douglas is entitled to summary judgment on Buyers' counterclaim challenging the validity of those claims.

B. Obviousness

All of Buyers' obviousness arguments concerning claims 29, 30, 31, 36 and 53-56 of the '978 patent are based on its erroneous belief that the MacQueen patent anticipates claim 28 of the '978 patent.³ In other words, Buyers' obviousness arguments fail because it fails to provide a piece of prior art that teaches "receiving said first and second arms, respectively upon relative movement therebetween in a direction generally parallel to the longitudinal axis of the vehicle." Buyers has failed to provide evidence from which a reasonable jury could find that the MacQueen patent teaches a limitation required by all the challenged claims.⁴ Accordingly, Douglas is entitled to summary judgment in its

³ For example, Buyers makes an obviousness argument using the MacQueen patent in conjunction with patent no. 4,127,951 with respect to claim 29, which is dependent on claim 28. Buyers uses the '951 patent to argue that putting receivers on the plow frame as opposed to on the mount frame would have been obvious. It does not, however, put forward any argument about the teaching in the '951 patent addressing the direction of movement limitation in claim 28 and the court will not make any such arguments for Buyers. *See United States v. Phillips*, 596 F.3d 414, 417-18 (7th Cir. 2010) (not responsibility of the court to make arguments for the parties). *See also Ruffin-Thompkins v. Experian Info. Solutions, Inc.*, 422 F.3d 603, 609-10 (7th Cir. 2005) (district court not required to search the record to find evidence to support arguments).

⁴ Because Douglas has moved for summary judgment on Buyers' allegations of invalidity, Buyers needed to put forth all the evidence and arguments necessary to defeat Douglas's motion. *See Siegel v. Shell Oil Co.*, 612 F.3d 932, 937 (7th Cir. 2010). It has failed to do so in so far as the invalidity of the '978 patent is concerned. Because Douglas's motion will be granted, whether the '978 patent is invalid is no longer at issue

favor on Buyers' defenses and counterclaims seeking to invalidate claims 29, 30, 31, 36 and 53-56 of the '978 patent for obviousness.⁵

III. The '530 Patent

Buyers contends that claims 1, 3-5 and 7 of the '530 patent are invalid because they are either anticipated by United States patent no. 5,195,261 (the Vachon patent) or made obvious in light of the Vachon patent and other prior art. Douglas contends that the Vachon patent, which was filed on April 16, 1992, does not qualify as prior art to the '530 patent and thus, cannot anticipate or make obvious the '530 patent's claims. Specifically, Douglas points to a draft patent application mailed on March 31, 1992, by Douglas's patent agent to the inventor of the '530 patent, (Olejniczak Decl., dkt. #198, ex. A.), as evidence that (1) the subject matter in the '530 patent was conceived *before* the Vachon patent's invention date and (2) reasonable diligence was exercised from that time until the formal patent application was filed in September 1992. This presents genuine issues of material fact to be decided by a jury and, therefore, Buyers' request for summary judgment on the invalidity of claims 1, 3-5 and 7 of the '530 patent will be denied.

To qualify as prior art, another patented invention must be known before the invention of the patent at issue. 35 U.S.C. § 102(a). Generally, the filing date of a patent is presumptively considered its invention date. *See, e.g., Ecolchem, Inc. v. S. Cal.*

in this case and any additional arguments Buyers has concerning invalidity of the '978 patent can no longer be presented to this court.

⁵ Even the one independent claim that Buyers provides an obvious argument for (claim 53) contains the identical direction of movement limitation found in claim 28 and Buyers points to the MacQueen patent in satisfaction of that element.

Edison Co., 227 F.3d 1361, 1371 (Fed. Cir. 2000). This is because “[t]he filing of a patent application is a constructive reduction to practice of the invention disclosed therein.” *Frazer v. Schlegel*, 498 F.3d 1283, 1288 (Fed. Cir. 2007). Normally, to prove that patent A serves as an anticipatory piece of prior art to patent B, the party seeking to invalidate patent B need only set forth that the filing date of patent A was before the filing date of patent B.

The party seeking to invalidate a patent, however, will have to prove more if the patentee produces evidence showing that he invented the subject matter of his patented invention before the filing date of alleged prior art patent. *Mahurkar v. C.R. Bard, Inc.*, 79 F.3d 1572, 1576-77 (Fed. Cir. 1996). This is because “[s]ection 102(a) explicitly refers to invention dates, not filing dates. Thus, under section 102(a), a document is prior art only when published before the invention date.” *Id.* at 1576. The party defending against an assertion that its patent is invalid in light of an alleged piece of prior art carries the burden of production, but not persuasion, with respect to the invention date of its patented invention. *Id.* at 1578. In other words, Douglas need only produce evidence to demonstrate that the inventor behind the ‘530 patent invented the subject matter of the patent before the filing of the Vachon patent; whereas Buyers carries the burden of persuading a jury by clear and convincing evidence that the invention in the ‘530 patent was not invented until application for that patent was filed on September 2, 1992 (some five months after the filing of the Vachon patent).

The invention date can either be (1) when the invention was actually reduced to practice or (2) at conception of the invention, if conception was followed by reasonable

diligence in later reducing the invention to practice. *Mahurkar*, 79 F.3d at 1577. Douglas does not assert that the invention in the '530 patent was actually reduced to practice before the Vachon patent was filed. Instead, Douglas asserts that the patented invention was conceived at least as early as March 31, 1992 (before the Vachon patent was filed) and that a mere five months later it was constructively reduced to practice when the official patent application was filed on September 2, 1992.

“To have conceived of an invention, an inventor must have formed in his or her mind a definite and permanent idea of the complete and operative invention, as it is hereafter to be applied in practice.” *Mahurkar*, 79 F.3d at 1577. The March 31, 1992 letter sent from Douglas’s patent agent to the inventor of the '530 patent, James Pieper, includes figures and draft claims language that for the most part are identical to that found in the actual '530 patent. (*See Olejniczak Decl.*, dkt. #198, ex. A.) This letter and attached draft patent application raise a genuine issue of material fact about whether the conception of the subject matter in the '530 patent predates the filing of the Vachon patent.

Buyers appears to suggest that the letter and draft patent application alone are not sufficient to establish conception because there is no additional corroborating evidence. (*See Def.’s Reply Br.*, dkt. #208, at 13.) Corroborating evidence, however, is required “where a party seeks to show conception through *oral* testimony of an inventor.” *Mahurkar*, 79 F.3d at 1577 (emphasis added). Corroboration is not required “where a party seeks to prove conception through the use of physical exhibits. The trier of fact can conclude for itself what documents show, aided by testimony as to what the exhibit

would mean to one skilled in the art.” *Id.* Douglas has provided the necessary evidence regarding conception in the form of the March 31, 1992 letter, attached draft patent application and expert opinion on the contents of the draft application by Douglas’s expert, Dr. Garris (*see* Garris Report, dkt. #134, ¶¶164-174).

There also is a genuine issue of fact as to whether the ‘530 parent was sought with reasonable diligence given a delay from March 31 to September 2, 1992, when the patent application for the ‘530 patent was actually filed. The March 31, 1992 letter itself offers some explanation for the delay in processing the formal patent application:

After you’ve approved the drawings, I’ll send [them] to our draftsman to prepare the formal Patent Office drawings.

....

Please give me a call if you have any specific questions. Otherwise return you[r] corrections by mail. As soon as your corrections are received, a revised draft of the application will be prepared and returned to you for further review.

(Olejniczak Decl., dkt. #198, ex. A at DD021646.) When viewed in a light most favorable to Douglas -- as is proper since Douglas on this issue is the non-moving party -- this language alone raises a genuine issue of material fact regarding the level of diligence used between March 31 and September 2, 1992. Buyers has offered no evidence that the five month gap between the potential March 31st conception and September 2nd filing of the formal application that became the ‘530 patent is unreasonable, much less that no trier of fact could reasonably find otherwise.

In sum, Buyers has failed to prove that no reasonable jury could reject the Vachon patent as prior art to the ‘530 patent, especially in light of its burden to prove by clear and convincing evidence that (1) the subject matter in the ‘530 patent was not conceived

before the filing of the Vachon patent, and (2) the inventor failed to proceed with reasonable diligence to the filing date after conception. Because genuine issues of material fact remain about whether the Vachon patent is prior art to the '530 patent, Buyers is not entitled to summary judgment on its invalidity counterclaims with respect to the '530 patent.

IV. The '480 and '700 Patents

Douglas also moved the court to enter summary judgment in its favor on Buyers' invalidity counterclaim with respect to the '480 patent. Buyers responded not with arguments or evidence but with a contention that it "reserves the right to raise the issue of the validity of [the '480 patent] in the event the claims are construed differently in the future." (Def.'s Br., dkt. #167, at 2 n.1.) Buyers misunderstands its burden as the nonmoving party faced with a summary judgment motion on an issue in which it carries the burden of proof at trial. As courts in the Seventh Circuit oft note, "[s]ummary judgment is the 'put up or shut up' moment in a lawsuit." *Siegel v. Shell Oil Co.*, 612 F.3d 932, 937 (7th Cir. 2010). The nonmoving party must provide specific facts showing a genuine issue for trial or face the possibility that summary judgment will be granted to the movant. Fed. R. Civ. P. 56(e)(2). Here, Douglas's summary judgment motion challenged Buyers to put forth the evidence it had supporting its affirmative contention that several of the claims of the '480 patent are invalid. Buyers chose to proffer no evidence. Accordingly, Buyers wholly failed to meet its burden of proof and no reasonable jury could find that any of the claims of the '480 patent are invalid.

Turning to the '700 patent, both parties cross-move for summary judgment on the the invalidity of many of the claims of the '700 patent, including independent claims 1, 38 and 45. The Court of Appeals for the Federal Circuit has held that a district court has the discretion to dismiss invalidity counterclaims upon a grant of summary judgment of non-infringement. *Phonometrics, Inc. v. Northern Telecom Inc.*, 133 F.3d 1459, 1468 (Fed. Cir. 1998); *Cardinal Chemical Co. v. Morton Int'l, Inc.*, 508 U.S. 83, 95 (1993) (in addressing motion for declaratory judgment district court has discretion to decide whether to exercise jurisdiction even when established). Exercising this discretion is particularly appropriate when non-infringement is clear and invalidity is not plainly evident. *Phonometrics, Inc.*, 133 F.3d at 1468 (citing *Leesona Corp. v. United States*, 530 F.2d 896, 906 n.9 (Ct. Cl. 1976)).

Here, Douglas has lost on summary judgment its claims of direct or indirect infringement with respect to the '700 patent. Whether the '700 patent is invalid is far less clear. Indeed, a finding of invalidity would require an analysis of no less than four pieces of prior art in combination, as well as review of numerous disputed facts bearing on four additional patents. Moreover, Buyers has given the court no reason to believe that further expenditure of judicial resources on these issues is justified by a risk of a future infringement suit based on the '700 patent, particularly given its expiration date is less than seven months away.

ORDER

IT IS ORDERED that:

- (1) Plaintiff Douglas Dynamics, LLC's motion for summary judgment that its United States patents nos. 5,420,480, Re. 35,700 and 6,944,978 are not invalid (dkt. #120) is
 - (a) GRANTED in so far as:
 - (i) The '480 and '978 patents are not invalid; and
 - (ii) Plaintiff is entitled to judgment in its favor on defendant Buyers Products Company's counterclaims that the '480 and '978 patents are invalid.
 - (b) The remainder of the motion is DENIED.
- (2) Defendant Buyers Product Company's motion for partial summary judgment that plaintiff's United States patents nos. Re. 35,700, 6,944,978 and 5,353,530 are invalid is DENIED.
- (3) Defendant's counterclaim asserting invalidity of the '700 patent is DISMISSED without prejudice.

Entered this 6th day of October, 2010.

BY THE COURT:

/s/

WILLIAM M. CONLEY
District Judge