

EXHIBIT 6

ALSTON & BIRD LLP

The Atlantic Building
950 F Street, NW
Washington, DC 20004-1404

202-756-3300
Fax: 202-756-3333
www.alston.com

Paul F. Brinkman

Direct Dial: 202-756-3404

E-mail: paul.brinkman@alston.com

December 29, 2009

CBI 10-082

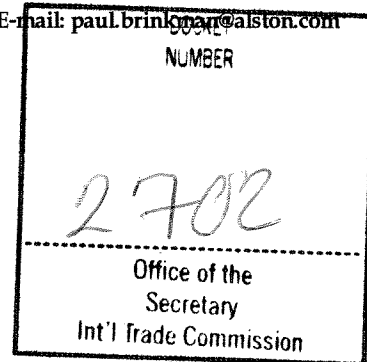

The Honorable Marilyn R. Abbott
Secretary
U.S. International Trade Commission
500 E Street, S.W., Room 112
Washington, DC 20436

Re: *In the Matter of Certain Electronic Products, Including Mobile Phones,
Portable Music Players and Computers*

Dear Secretary Abbott:

Enclosed for filing on behalf of Nokia Corporation and Nokia Inc. (collectively "Nokia") are the following documents supporting Nokia's request that the International Trade Commission commence an investigation under Section 337 of the Tariff Act of 1930, as amended. A separate letter requesting confidential treatment of Confidential Exhibits 19-21, 23-28, 30, 36-39, 42, 44-46 and 50-57 is included with this filing.

1. One (1) original and twelve (12) copies of Nokia's verified complaint (original and one copy unbound);
2. One (1) original and six copies of the confidential version of the exhibits to the complaint (one copy unbound, without tabs);
3. One (1) original and six copies of the non-confidential version of the exhibits to the complaint (one copy unbound, without tabs);
4. One (1) additional copy of the complaint and the accompanying non-confidential exhibits for service upon the proposed respondent; and one additional copy of the confidential exhibits for service upon counsel for the respondent after appropriate subscriptions to a protective order have been filed;
5. One (1) original and three (3) copies of the Appendices to the complaint (one copy unbound, without tabs, and an additional copy of each bound certified prosecution history);

6. One (1) box containing physical exhibits labeled as follows:
 - a. A sample of the Apple iPhone 3GS mobile phone submitted as Physical Exhibit 1;
 - b. A sample of the accused Apple iPod Nano portable music player submitted as Physical Exhibit 2;
 - c. A sample Nokia 7205 mobile phone submitted as Physical Exhibit 3;
 - d. A sample Nokia E61i mobile phone submitted as Physical Exhibit 4;
 - e. A sample Nokia E71x mobile phone submitted as Physical Exhibit 5;
 - f. A sample Nokia 5800 mobile phone submitted as Physical Exhibit 6;
 - g. A sample Nokia N85 mobile phone submitted as Physical Exhibit 7.

In accordance with 19 C.F.R. § 210.12(a) and (c), the following documents are submitted within the exhibits or appendices to the complaint:

- One (1) certified copy of U.S. Patent No. 6,714,091 (“the 091 Patent”) is included as Exhibit 1 to the complaint;
- A certified copy of the assignment for the 091 Patent is included as Exhibit 8 to the complaint;
- A certified copy and four (4) copies of the prosecution history for the 091 Patent is included as Appendix A;
- The original and three (3) copies of each reference document mentioned in the prosecution history of the 091 Patent is included as Appendix B;
- One (1) certified copy of U.S. Patent No. 6,834,181 (“the 181 Patent”) is included as Exhibit 2 to the complaint;
- A certified copy of the assignment for the 181 Patent is included as Exhibit 9 to the complaint;
- A certified copy and four (4) copies of the prosecution history for the 181 Patent is included as Appendix C;
- The original and three (3) copies of each reference document mentioned in the prosecution history of the 181 Patent is included as Appendix D;

- One (1) certified copy of U.S. Patent No. 6,895,256 (“the 256 Patent”) is included as Exhibit 3 to the complaint;
- A certified copy of the assignment for the 256 Patent is included as Exhibit 10 to the complaint;
- A certified copy and four (4) copies of the prosecution history for the 256 Patent is included as Appendix E;
- The original and three (3) copies of each reference document mentioned in the prosecution history of the 256 Patent is included as Appendix F;
- One (1) certified copy of U.S. Patent No. 6,518,957 (“the 957 Patent”) is included as Exhibit 4 to the complaint;
- A certified copy of the assignment for the 957 Patent is included as Exhibit 11 to the complaint;
- A certified copy and four (4) copies of the prosecution history for the 957 Patent is included as Appendix G;
- The original and three (3) copies of each reference document mentioned in the prosecution history of the 957 Patent is included as Appendix H;
- One (1) certified copy of U.S. Patent No. 6,073,036 (“the 036 Patent”) is included as Exhibit 5 to the complaint;
- A certified copy of the assignment for the 036 Patent is included as Exhibit 12 to the complaint;
- A certified copy and four (4) copies of the prosecution history for the 036 Patent is included as Appendix I;
- The original and three (3) copies of each reference document mentioned in the prosecution history of the 036 Patent is included as Appendix J;
- One (1) certified copy of U.S. Patent No. 6,262,735 (“the 735 Patent”) is included as Exhibit 6 to the complaint;
- A certified copy of the assignment for the 735 Patent is included as Exhibit 13 to the complaint;
- A certified copy and four (4) copies of the prosecution history for the 735 Patent is included as Appendix K;

- The original and three (3) copies of each reference document mentioned in the prosecution history of the 735 Patent is included as Appendix L;
- One (1) certified copy of U.S. Patent No. 6,924,789 (“the 789 Patent”) is included as Exhibit 7 to the complaint;
- A certified copy of the assignment for the 789 Patent is included as Exhibit 14 to the complaint;
- A certified copy and four (4) copies of the prosecution history for the 789 Patent is included as Appendix M;
- The original and three (3) copies of each reference document mentioned in the prosecution history of the 789 Patent is included as Appendix N;
- Identification of each licensee under each involved U.S. patent, submitted as Confidential Exhibit 51.

Thank you for your attention to this matter. Please contact the undersigned if there are any questions pertaining to this submission.

Sincerely,

A handwritten signature in black ink, appearing to read 'Paul F. Brinkman', with a long horizontal flourish extending to the right.

Paul F. Brinkman

ALSTON & BIRD LLP

The Atlantic Building
950 F Street, NW
Washington, DC 20004-1404

202-756-3300
Fax: 202-756-3333
www.alston.com

Paul F. Brinkman

Direct Dial: 202-756-3404

E-mail: paul.brinkman@alston.com

REQUEST FOR CONFIDENTIAL TREATMENT

December 29, 2009

The Honorable Marilyn R. Abbott
Secretary
U.S. International Trade Commission
500 E Street, S.W., Room 112
Washington, DC 20436

Re: *In the Matter of Certain Electronic Products, Including Mobile Phones,
Portable Music Players and Computers*

Dear Secretary Abbott:

In accordance with 19 C.F.R. §§ 201.6 and 210.5, Complainants Nokia Corporation and Nokia Inc. (collectively "Nokia") request confidential treatment for the business information contained in Confidential Exhibits 19-21, 23-28, 30, 36-39, 42, 44-46 and 50-57 to Nokia's complaint.

The information for which confidential treatment is sought is proprietary technical and commercial information, including:

1. Proprietary technical information relating to Apple products prepared by third parties. (Confidential Exhibits 19-21, 23-28 and 30);
2. Proprietary technical information regarding Nokia's products. (Confidential Exhibits 36-39, 42, 44-46, 50);
3. Identification of licensees under the asserted patents. (Confidential Exhibit 51); and

The Honorable Marilyn R. Abbott

December 29, 2009

Page 2

4. Proprietary commercial information regarding Nokia's domestic investments in research and development, testing and repair and service. (Confidential Exhibits 52-57).

Neither the information described above nor substantially identical information is available to the public. *See* attached certification per Rule 201(b)(3)(iii). Unauthorized disclosure of this information could cause substantial harm to the competitive position of Nokia and the third parties from which the information was obtained. The disclosure of this information could also impair the Commission's ability to obtain information necessary to perform its statutory functions.

Non-confidential copies of the above exhibits have been submitted where practicable pursuant to Rule 201.8(d).

Thank you for your attention to this matter. Please contact the undersigned if there are any questions pertaining to this submission.

Sincerely,

A handwritten signature in black ink, appearing to read 'P. Brinkman', with a long horizontal flourish extending to the right.

Paul F. Brinkman

CERTIFICATION

I, Paul F. Brinkman, attorney for Complainants Nokia Corporation and Nokia Inc., declare:

1. I am duly authorized by Complainants to execute this certification.
2. I have reviewed Confidential Exhibits 19-21, 23-28, 30, 36-39, 42, 44-46 and 50-57 to Nokia's complaint, for which confidential treatment has been requested.
3. To the best of my knowledge, information and belief, founded after reasonable inquiry, substantially identical information is not available to the public.

I declare under penalty of perjury that the foregoing is true and correct.

Executed this 29th day of December, 2009, in Washington, D.C.

A handwritten signature in black ink, appearing to read 'P. Brinkman', written over a horizontal line.

Paul F. Brinkman

**UNITED STATES INTERNATIONAL TRADE COMMISSION
WASHINGTON, D.C.**

In the Matter of

CERTAIN ELECTRONIC DEVICES,
INCLUDING MOBILE PHONES,
PORTABLE MUSIC PLAYERS, AND
COMPUTERS

Investigation No. 337-TA- _____

**COMPLAINT UNDER SECTION 337 OF
THE TARIFF ACT OF 1930, AS AMENDED**

Complainants:

Nokia Corporation
Keilalahdentie 4
(P.O. Box 226)
FIN-00045 Nokia Group
Espoo
Finland
Tel: 358 (0) 7180-08000

Nokia Inc.
102 Corporate Park Drive
White Plains, NY 10604
Tel: (914) 368-0400

Proposed Respondent:

Apple Inc.
1 Infinite Loop
Cupertino, California 95014
Tel: (408) 996-1010

Counsel for Complainants:

Paul F. Brinkman
Alan L. Whitehurst
ALSTON & BIRD LLP
The Atlantic Building
950 F Street, N.W.
Washington, D.C. 20004-1404
Tel: (202) 756-3300
Fax: (202) 756-3333
E-mail: nokia-apple-itc@alston.com

Patrick J. Flinn
Keith E. Broyles
John D. Haynes
ALSTON & BIRD LLP
One Atlantic Center
1201 West Peachtree Street
Atlanta, GA 30309-3424
Tel: (404) 881-7000
Fax: (404) 881-7777

TABLE OF CONTENTS

LIST OF EXHIBITS.....	iv
LIST OF APPENDICES.....	vii
LIST OF PHYSICAL EXHIBITS	viii
I. INTRODUCTION	1
II. THE COMPLAINANTS	2
A. Nokia Corporation	2
B. Nokia Inc.....	3
III. THE PROPOSED RESPONDENT APPLE INC.	3
IV. THE TECHNOLOGY AND PRODUCTS IN ISSUE.....	4
V. THE ASSERTED PATENTS AND NON-TECHNICAL DESCRIPTIONS OF THE INVENTIONS THEREIN	8
A. Ownership of the Asserted Patents	8
B. The 091 Patent	8
C. The 181 Patent	9
D. The 256 Patent	11
E. The 957 Patent	13
F. The 036 Patent	14
G. The 735 Patent	16
H. The 789 Patent	17
I. Foreign Counterparts of the Asserted Patents.....	19
J. Licensees Under the Asserted Patents	19
VI. APPLE'S INFRINGEMENT OF THE ASSERTED PATENTS.....	19
A. Apple's Infringement of the 091 Patent	19
1. Direct Infringement.....	20

2.	Contributory Infringement	20
3.	Inducement of Infringement	21
B.	Apple's Infringement of the 181 Patent	21
1.	Direct Infringement.....	21
2.	Contributory Infringement.....	22
3.	Inducement of Infringement	22
C.	Apple's Infringement of the 256 Patent	23
1.	Direct Infringement.....	23
2.	Contributory Infringement.....	24
3.	Inducement of Infringement	24
D.	Apple's Infringement of the 957 Patent	24
1.	Direct Infringement.....	25
2.	Contributory Infringement.....	25
3.	Inducement of Infringement	26
E.	Apple's Infringement of the 036 Patent	26
1.	Direct Infringement.....	27
2.	Contributory Infringement.....	27
3.	Inducement of Infringement	28
F.	Apple's Infringement of the 735 Patent	28
1.	Direct Infringement.....	29
2.	Contributory Infringement.....	29
3.	Inducement of Infringement	30
G.	Apple's Infringement of the 789 Patent	30
1.	Direct Infringement.....	30
2.	Contributory Infringement	31

3.	Inducement of Infringement	31
VII.	APPLE'S UNFAIR TRADE PRACTICES.....	32
VIII.	TARIFF NUMBERS APPLICABLE TO THE ACCUSED PRODUCTS.....	33
IX.	RELATED LITIGATION	33
X.	THE DOMESTIC INDUSTRY	33
A.	Nokia's Articles Protected by the Asserted Patents	33
B.	Nokia's Investments in the United States with respect to the Articles Protected by the Asserted Patents	34
1.	Investments Relating to Engineering and Research and Development	35
2.	Investments Relating to Testing.....	36
3.	Investments Relating to Repair and Service	37
XI.	COMPLAINANTS' REQUEST FOR RELIEF	37

LIST OF EXHIBITS

<u>Exhibit</u>	<u>Description</u>
1.	Certified Copy of U.S. Patent No. 6,714,091
2.	Certified Copy of U.S. Patent No. 6,834,181
3.	Certified Copy of U.S. Patent No. 6,895,256
4.	Certified Copy of U.S. Patent No. 6,518,957
5.	Certified Copy of U.S. Patent No. 6,073,036
6.	Certified Copy of U.S. Patent No. 6,262,735
7.	Certified Copy of U.S. Patent No. 6,924,789
8.	Certified Copy of Assignment of U.S. Patent No. 6,714,091
9.	Certified Copy of Assignment of U.S. Patent No. 6,834,181
10.	Certified Copy of Assignment of U.S. Patent No. 6,895,256
11.	Certified Copy of Assignment of U.S. Patent No. 6,518,957
12.	Certified Copy of Assignment of U.S. Patent No. 6,073,036
13.	Certified Copy of Assignment of U.S. Patent No. 6,262,735
14.	Certified Copy of Assignment of U.S. Patent No. 6,924,789
15.	Nokia Corporation's 2008 Form 20-F
16.	Apple Inc.'s 2008 Form 10-K
17.	List of Foreign Counterparts for the Asserted Patents
18.	Information regarding the Apple iPhone 3GS Mobile Phone
19.	CONFIDENTIAL information regarding the Apple iPhone 3GS Mobile Phone
20.	CONFIDENTIAL Information regarding the RF transceiver found within an Apple iPhone 3GS Mobile Phone
21.	CONFIDENTIAL Information regarding the camera found within an Apple iPhone 3GS Mobile Phone
22.	Information regarding the Apple iPod Nano Portable Music Player

23. CONFIDENTIAL Information regarding the Apple iPod Nano Portable Music Player
24. CONFIDENTIAL Claim chart showing infringement of the 091 patent by Apple's iPhone 3GS Mobile Phone
25. CONFIDENTIAL Claim chart showing infringement of the 181 patent by Apple's iPhone 3GS Mobile Phone
26. CONFIDENTIAL Claim chart showing infringement of the 256 patent by Apple's iPhone 3GS Mobile Phone
27. CONFIDENTIAL Claim chart showing infringement of the 957 patent by Apple's iPhone 3GS Mobile Phone
28. CONFIDENTIAL Claim chart showing infringement of the 036 patent by Apple's iPhone 3GS Mobile Phone
29. Claim chart showing infringement of the 735 patent by Apple's iPhone 3GS Mobile Phone
30. CONFIDENTIAL Claim chart showing infringement of the 789 patent by Apple's iPod Nano Portable Music Player
31. Declaration of Laura Williams
32. Photographs of the Apple iPhone 3GS Mobile Phone (Physical Exhibit P1)
33. Photographs of the Apple iPod Nano (Physical Exhibit P2), iPod Touch and iPod Classic Portable Music Players
34. Photographs of the Apple MacBook and iMac Computers
35. Photographs of the Nokia 7205, E61i, E71x, 5800 and N85 mobile phones (Physical Exhibits P3-P7)
36. CONFIDENTIAL Information regarding a processor chip in the Nokia 7205 mobile phone
37. CONFIDENTIAL Information regarding an RF chip in the Nokia 7205 mobile phone
38. CONFIDENTIAL Information regarding the E62 mobile phone
39. CONFIDENTIAL Information regarding the Nokia E71x mobile phone
40. Information regarding the E71x mobile phone
41. Information regarding the Nokia 5800 mobile phone
42. CONFIDENTIAL information regarding the Nokia N85 mobile phone

43. Information regarding the Nokia N85 mobile phone
44. CONFIDENTIAL Claim chart showing that the Nokia 7205 mobile phone practices the 091 patent
45. CONFIDENTIAL Claim chart showing that the Nokia E62 (and E61i) mobile phones practice the 181 patent
46. CONFIDENTIAL Claim chart showing that the Nokia E71x mobile phone practices the 256 patent
47. Claim chart showing that the Nokia 5800 mobile phone practices the 957 patent
48. Claim chart showing that the Nokia 5800 mobile phone practices the 036 patent
49. Claim chart showing that the Nokia E71x mobile phone practices the 735 patent
50. CONFIDENTIAL Claim chart showing that the Nokia N85 (and N78 and N81) mobile phones practice the 789 patent
51. CONFIDENTIAL List of Licensees
52. CONFIDENTIAL Declaration of Jari Niemela
53. CONFIDENTIAL Declaration of Jerry Harris
54. CONFIDENTIAL Declaration of Paul Haverstock
55. CONFIDENTIAL Declaration of Larry Paulson
56. CONFIDENTIAL Declaration of Esa Juntunen
57. CONFIDENTIAL Declaration of Kelly Matejka

LIST OF APPENDICES

<u>Appendix</u>	<u>Description</u>
A.	Certified Copy of Prosecution History for U.S. Patent No. 6,714,091
B.	Copy of each reference cited in the 091 Patent and its Prosecution History
C.	Certified Copy of Prosecution History for U.S. Patent No. 6,834,181
D.	Copy of each reference cited in the 181 Patent and its Prosecution History
E.	Certified Copy of Prosecution History for U.S. Patent No. 6,895,256
F.	Copy of each reference cited in the 256 Patent and its Prosecution History
G.	Certified Copy of Prosecution History for U.S. Patent No. 6,518,957
H.	Copy of each reference cited in the 957 Patent and its Prosecution History
I.	Certified Copy of Prosecution History for U.S. Patent No. 6,073,036
J.	Copy of each reference cited in the 036 Patent and its Prosecution History
K.	Certified Copy of Prosecution History for U.S. Patent No. 6,262,735
L.	Copy of each reference cited in the 735 Patent and its Prosecution History
M.	Certified Copy of Prosecution History for U.S. Patent No. 6,924,789
N.	Copy of each reference cited in the 789 Patent and its Prosecution History

LIST OF PHYSICAL EXHIBITS

<u>Exhibit</u>	<u>Description</u>
P1.	Apple iPhone 3GS mobile phone
P2.	Apple iPod Nano portable music player
P3	Nokia 7205 mobile phone
P4.	Nokia E61i mobile phone
P5.	Nokia E71x mobile phone
P6.	Nokia 5800 mobile phone
P7.	Nokia N85 mobile phone

I. INTRODUCTION

1. Complainants Nokia Corporation and Nokia Inc. (collectively "Nokia") file this Complaint under Section 337 of the Tariff Act of 1930, as amended, 19 U.S.C. § 1337 ("Section 337"), based upon the unlawful importation into the United States, the sale for importation, and/or the sale within the United States after importation of certain electronic devices, including mobile phones, portable music players, and computers.

2. The proposed respondent is Apple, Inc. ("Apple").

3. This Complaint is directed to Apple's imported electronic devices, including at least the iPhone, iPhone 3G, and iPhone 3GS mobile phones, iPod Nano, iPod Touch, and iPod Classic portable music players, and iMac, Mac Mini, Mac Pro, MacBook, MacBook Pro, and MacBook Air computers (collectively the "Accused Products"¹) that infringe claims 1-12 of United States Patent No. 6,714,091 ("091 patent"); claims 1-6 and 8 of United States Patent No. 6,834,181 ("181 patent"); claims 1, 3, 6-10, 14, and 16 of United States Patent No. 6,895,256 ("256 patent"); claims 1, 10-13, 16, 19, 22, and 25 of United States Patent No. 6,518,957 ("957 patent"); claims 1, 3, 6, 8-10, 13, 17, and 19 of United States Patent No. 6,073,036 ("036 patent"); claims 1-3 and 7-10 of United States Patent No. 6,262,735 ("735 patent"); and/or claim 5 of United States Patent No. 6,924,789 ("789 patent") (collectively the "Asserted Patents").

4. An industry as required by 19 U.S.C. §§ 1337(a)(2) and (3) exists in the United States relating to articles protected by the Asserted Patents.

¹ The term "Accused Products" encompasses all of Apple's electronic devices, including mobile phones, portable music players, and computers with functionality that comes within the scope of the Asserted Patents' claims. Upon further investigation and discovery, Nokia may identify additional Accused Products and/or seek to assert additional claims.

5. Nokia seeks a permanent exclusion order prohibiting the entry of Apple's infringing electronic devices into the United States. Nokia also requests a permanent cease and desist order prohibiting Apple from importing, admitting or withdrawing from a foreign trade zone, marketing, advertising, demonstrating, warehousing inventory for distribution, distributing, offering for sale, selling, licensing, repairing, maintaining, updating, using, or transferring outside the United States for sale in the United States infringing electronic devices.

II. THE COMPLAINANTS

A. Nokia Corporation

6. Nokia Corporation was founded in 1865 and is the world's largest manufacturer of mobile phones. Nokia is one of the champions of wireless communications and has received numerous awards and accolades for its achievements, including introducing the first car phone on the first international cellular mobile network in 1981.

7. Nokia's innovations have continued throughout the wireless era to the smart phones of the present day. In 1991, the world's first genuine call on the Global System for Mobile communications ("GSM") was made with a Nokia phone. In 1996, Nokia introduced the Nokia 9000 Communicator, which was the first all-in-one phone, fax, calendar, e-mail, and Internet device in a hand-portable size. The Nokia 8110i, introduced in 1997, was the first mobile phone with a dynamic menu supporting Smart Messaging. Just two years later, Nokia introduced the Nokia 7110 – the first mobile phone compliant with Wireless Application Protocol 1.1 – which provided access to mobile Internet services, such as banking, e-mail, and news, as well as the first phone with predictive text input.

8. In 2001, Nokia made the world's first 3G Universal Mobile Telecommunications System ("UMTS") voice call on a commercial system. In 2002, Nokia introduced the world's first UMTS/GSM dual mode phone and launched in Europe the Nokia 7650, its first imaging

phone with an integrated camera and the first Nokia phone to record video simultaneously with sound. The Nokia 5140, launched in 2003, was the first Push-to-Talk GSM handset. In 2006, Nokia introduced the N95, which was the first device with built-in Global Positioning System ("GPS") technology. In 2008, Nokia released the E71, the world's slimmest smart phone.

9. Research is one of the keys to Nokia's success. As of December 2008, Nokia had a research and development presence in 16 countries and employed over 39,000 people in research and development alone. Through over 40 billion Euros in cumulative research and development investment, Nokia has achieved the innovations found in the Asserted Patents – all of which were developed in-house – and in over 11,000 other patent families in its portfolio. Nokia continues to be a leader in mobile communications worldwide, investing nearly 6 billion Euros in 2008 for research and development.

B. Nokia Inc.

10. Nokia Inc. is a corporation existing under the laws of the State of Delaware with its principal place of business in White Plains, New York. Nokia Inc. is a wholly-owned subsidiary of Nokia Corporation.

11. Nokia Inc. currently employs nearly 3,000 people throughout the United States, including over 1,000 people who work in research and development in facilities across the United States. In 2008, Nokia Inc. had over \$1 billion in sales in the United States.

12. Further information regarding Nokia Corporation and Nokia Inc. may be found in Exhibit 15, which includes Nokia Corporation's 2008 Form 20-F.

III. THE PROPOSED RESPONDENT APPLE INC.

13. Proposed Respondent Apple Inc. is a corporation existing under the laws of the state of California, with its principal place of business at 1 Infinite Loop, Cupertino, California 95014.

14. Apple is in the business of importing and selling electronic devices, including mobile phones, portable music players and computers.

15. Further information regarding Apple may be found in Exhibit 16, which includes Apple's 2008 Form 10-K.

IV. THE TECHNOLOGY AND PRODUCTS IN ISSUE

16. The Asserted Patents are a reflection of the breadth of Nokia's extensive dedication and investment in technology. Ever since Nokia's first car phone in 1981, Nokia has continuously endeavored to make the world's best mobile phones and enhance the user's experience with diverse and advanced functionality. Whether it is designing more efficient mobile phones that use less power, manufacturing the world's slimmest smart phones, or developing some of the first touch screen products, Nokia has taken great strides to stay ahead of its competition. Nokia's innovations have been applied in many electronic devices other than mobile phones, such as portable music players and computers.

17. Mobile phones have come a long way since the car phones and briefcase phones of the 1980s. Today's mobile phones are small and typically weigh less than five ounces. While consumers demand smaller and lighter mobile phones, they also want their phones to have long battery life. One of the limiting factors on mobile phone size has always been the battery. In order to maximize the life of a given sized battery, it is important to incorporate power saving techniques into the mobile phone. As explained below, the 091 patent relates to a programmable voltage controlled oscillator ("VCO") that increases the efficiency of the wireless device and uses less power than traditional VCOs, thereby increasing battery life.

18. Another limiting factor on mobile phone size has been the antenna and speaker assemblies. As explained below, the 181 patent involves combining the two assemblies to save space. In the 181 patent, the combined assembly is further improved because it contains multiple

acoustic cavities that improve the sound quality of a hands-free speaker. This patented technology is valuable to reducing the overall size of the phone while increasing its performance.

19. Most of today's mobile phones, including Apple's iPhone, have a camera. Apple's MacBook computers also have a built-in camera, and earlier this year, Apple added a camera to its iPod Nano portable music player. Cameras add to the size and weight of the electronic device. The 256 patent involves reducing the overall chip count on the printed circuit board. This patented technology is valuable in reducing the overall size of the electronic device and its power consumption.

20. Many of today's wireless electronic devices, including the iPhone mobile phone and the iPod Touch portable music player, are used for a wide variety of tasks, such as sending email, browsing the Internet, and downloading applications. From a very early date, Nokia recognized that a touch screen could be used to enter information to the electronic device. But touch screens have their own challenges. The 957 patent involves deactivating the touch screen during phone calls so that information is not accidentally inputted via the touch screen when the phone is pressed against the ear. The 036 patent makes it easier to input information using a finger by magnifying or expanding the selected portion of the screen. These patented features are valuable to improving the appeal and performance of electronic devices with touch screens.

21. E-mail, text messaging, and other electronic communications have become a fundamental part of our lives, and Apple's computers, mobile phones, and even the iPod Touch portable music player now have applications that involve electronic messaging. Nokia has been an innovator in creating new and useful features for communicating electronically. The 735 patent introduced a way to link to other applications on electronic devices through an electronic message. When a message is received that includes, for example, a phone number, the 735

patent makes it possible to easily select that phone number to launch a corresponding phone application. This patented technology has become a feature we use on a daily basis to increase the integration of all of the different applications on our computers and other devices.

22. Electronic devices use a variety of input devices to enter text and commands. Apple's products, such as its iPod Nano and iPod Classic portable music players, have a clickwheel interface that allows a user to interact with the device in more than one way. Nokia has long been an innovator in creating new and different ways for a user to interact with electronic devices. The 789 patent introduces a way to both press a key to enter data, and to use a touch sensitive input to navigate through applications. This patented technology is used in devices such as mobile phones and portable music players to provide a more advanced user interactive experience.

23. The Asserted Patents are sometimes referred to as "implementation patents" (as opposed to "essential patents"). Implementation patents are not essential to any relevant wireless communication standards, and, therefore, do not implicate contractual licensing obligations required by membership in many wireless communication standard setting organizations. Nokia's implementation patents – including the Asserted Patents – are particularly important to Nokia's success because they permit Nokia to differentiate its products from those of its competitors.

24. On December 11, 2009, Apple accused Nokia of infringing patents that Apple claims relate to mobile phones.² Apple's allegations boast that it "produced cutting-edge, technologically superior, and user friendly devices" – including its iPhone line of mobile

² Apple Inc.'s Answer, Defenses, and Counterclaims, *Nokia Corporation v. Apple Inc.*, C.A. 09-791 (D. Del.).

phones.³ Yet many of Apple's alleged innovations result from technology first invented and patented by Nokia. For example, among the "cutting-edge" technologies in its iPhone, Apple touts a "3-megapixel camera" and "longer battery life."⁴ But Nokia had incorporated a camera in a mobile phone as early as 2002 – five years before the iPhone was introduced. The camera incorporated in Apple's iPhones even appropriates a Nokia invention claimed in the 256 patent. Similarly, Apple is able to extend the battery life on its iPhone by using Nokia's power-efficiency invention found in the 091 patent. Furthermore, Apple reduces the iPhone's size and boosts its speaker performance by housing the phone's speaker and acoustic cavities in the same space as the antenna, as described in Nokia's 181 patent.

25. Apple also claims to have incorporated features to make its iPhone "user friendly," but those features are also based on technology invented and patented by Nokia. For example, the touch screen in the iPhone is deactivated during a phone call as claimed in the 957 patent, and the iPhone magnifies selected characters using the invention of Nokia's 036 patent. And while Apple purports to have "foreseen" the "convergence" of the mobile phone with computers to produce the "smartphone,"⁵ it was Nokia that first adapted many of the computer-related features to mobile phones that Apple now imitates, such as launching applications as disclosed in the 735 patent.

26. Apple's unauthorized use of Nokia's inventions is consistent with a long-standing Apple corporate tradition. In 1996, Apple founder and CEO Steve Jobs appeared in the PBS documentary, "Triumph of the Nerds," and freely acknowledged Apple's use of other's ideas.

³ *Id.* at Answer ¶ 5.

⁴ *Id.* at Counterclaims ¶ 19.

⁵ *Id.* at Answer ¶ 5.

"Picasso had a saying," Jobs stated in the interview, "good artists copy, great artists steal." Jobs then added, "and we have always been shameless about stealing great ideas."⁶

V. THE ASSERTED PATENTS AND NON-TECHNICAL DESCRIPTIONS OF THE INVENTIONS THEREIN⁷

A. Ownership of the Asserted Patents

27. Nokia Corporation owns by assignment the entire right, title, and interest in and to each of the Asserted Patents. Certified copies of the assignments for each of the Asserted Patents are attached as Exhibits 8-14.

B. The 091 Patent

28. U.S. Patent No. 6,714,091, entitled "VCO With Programmable Output Power," issued on March 30, 2004 to inventors Soren Norskov, Carsten Rasmussen, and Niels Thomas Hedegaard Povlsen. The 091 patent issued from United States Patent Application Serial No. 09/739,230, filed on December 19, 2000. The 091 patent expires on December 19, 2020.

29. A certified copy of the 091 patent is attached as Exhibit 1.

30. A certified copy of the prosecution history of the 091 patent and copies of each reference cited in the 091 patent and prosecution history are included in Appendices A and B, respectively.

31. The 091 patent has 13 claims, 2 of which are independent claims. Complainants are asserting claims 1-12.

⁶ Transcript available at <http://www.pbs.org/nerds/part3.html>.

⁷ All non-technical descriptions of the inventions herein are presented to give a general background of those inventions. These statements are not intended to be used nor should they be used for purposes of patent claim interpretation. Complainants present these statements subject to and without waiver of their right to argue that claim terms should be construed in a particular way as contemplated by claim interpretation jurisprudence and the relevant evidence.

32. In wireless communication devices, a circuit called a voltage controlled oscillator is used to generate high frequency radio signals. At the transmitter, the high frequency signal is used to "carry" the information to the receiver. At the receiver, the high frequency signal is used to remove the "carrier signal" to recover the original information. Traditionally, VCOs operated at a constant power level that wasted energy and drained battery life.

33. While working to improve Nokia's mobile phones, the inventors of the 091 patent devised a VCO whose output power is controlled or regulated by a micro-controller. As shown in Figure 1 of the 091 patent (reproduced below), a micro-controller (element 16) controls the output of the VCO assembly (element 3). The VCO provides more output power when needed, and less power when *not* needed, such that the battery life of the phone is extended. Use of this invention allows Nokia to make smaller, more efficient mobile phones with longer battery life.

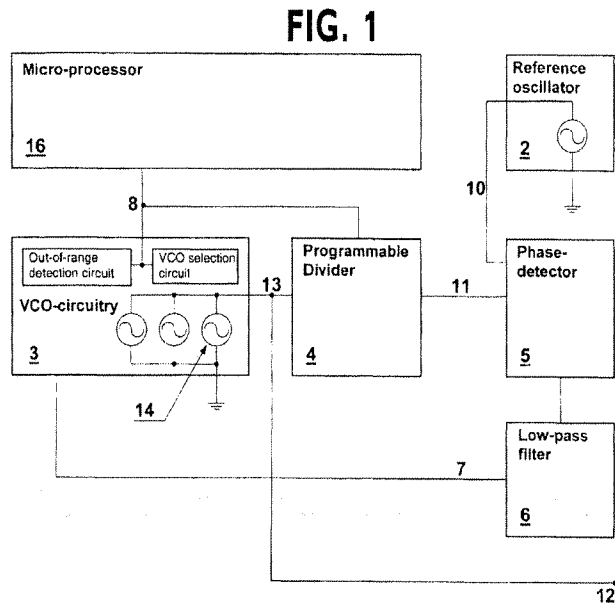

C. The 181 Patent

34. U.S. Patent No. 6,34,181, entitled "Mobile Communication Device and Related Construction Method," issued on December 21, 2004 to inventors Terho Kaikuranta, Seppo

Salminen, Heikki Halkosaari, and Jussi Hakunti. The 181 patent issued from United States Patent Application Serial No 10/099,476, filed on March 13, 2002. The 181 patent expires on March 13, 2022 plus a patent term extension of 314 days.

35. A certified copy of the 181 patent is attached as Exhibit 2.

36. A certified copy of the prosecution history of the 181 patent and copies of each reference cited in the 181 patent and prosecution history are included in Appendices C and D, respectively.

37. The 181 patent has 15 claims, 4 of which are independent claims. Complainants are asserting claims 1-6 and 8.

38. Not only is there an increased demand for smaller and lighter mobile telephones, but there is also an increased demand for mobile telephones with high quality hands-free ("HF") speakers. However, in order for a HF speaker to work properly there needs to be a certain amount of air around the speaker. The inventors of the 181 patent recognized that by combining the antenna and speaker assemblies and creating multiple acoustic cavities around the speaker they could make both the antenna and speaker perform better without increasing the overall size of the device.

39. As shown in Figure 1 of the 181 patent (reproduced below), traditionally the antenna was located in a different location than the HF speaker. As shown in Figure 5 of the 181 patent (also reproduced below), the inventors of the 181 patent recognized that by placing the antenna in the same space as the HF speaker while dividing the speaker space into multiple acoustic cavities, the sound quality of the HF speaker is increased without increasing the size of the mobile phone.

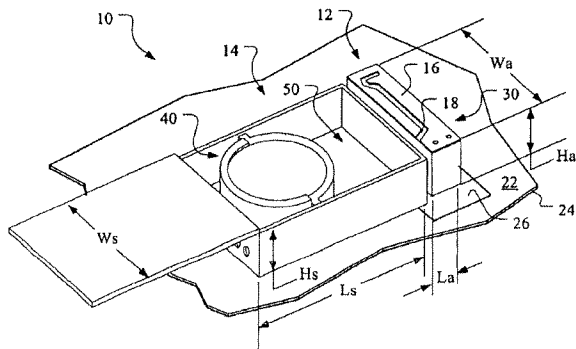

FIG. 1
PRIOR ART

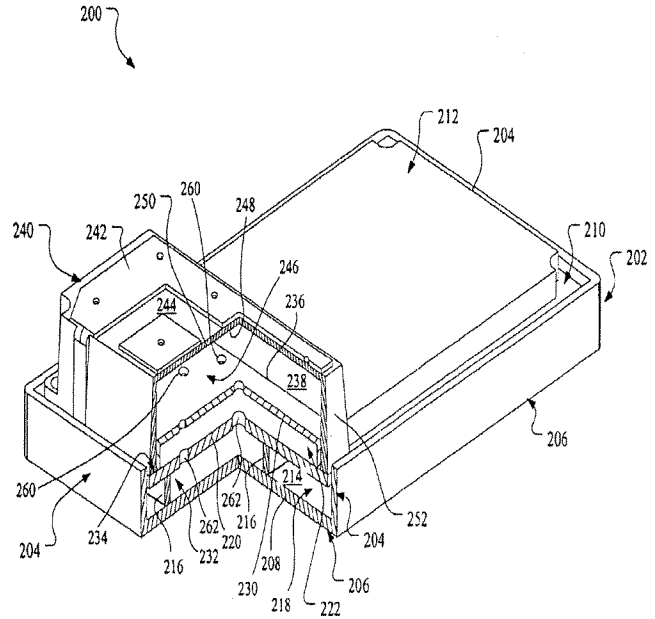

FIG. 5

40. In the figures above, Figure 1 represents a prior art design and Figure 5 depicts an embodiment of the invention. The antenna is represented by reference numeral 16 in Figure 1 and reference numeral 242 in Figure 5. The speaker space is represented by reference numeral 50 in Figure 1, and reference numeral 246 in Figure 5. In Figure 1, the antenna 16 is in a separate area from the speaker space 50. In Figure 5, the antenna 242 shares the same space as the speaker 232. The speaker space is divided into multiple acoustic cavities (246 and 222). Using this innovative speaker arrangement, Nokia is able to make some of the world's smallest and lightest mobile phones, while still providing excellent hands-free operation and speaker audio quality.

D. The 256 Patent

41. U.S. Patent No. 6,895,256, entitled "Optimized Camera Sensor Architecture for a Mobile Telephone," issued on May 17, 2005 to inventors Esa Härmä and Kristian Vaajala. The 256 patent issued from United States Patent Application Serial No. 09/732,316, filed on

December 7, 2000. The 256 patent expires on December 7, 2020 plus a patent term extension of 535 days.

42. A certified copy of the 256 patent is attached as Exhibit 3.

43. A certified copy of the prosecution history of the 256 patent and copies of each reference cited in the 256 patent and prosecution history are included in Appendices E and F, respectively.

44. The 256 patent has 21 claims, 1 of which is an independent claim. Complainants are asserting claims 1, 3, 6-10, 14, and 16.

45. As electronic devices are increasingly used to provide additional functionality to consumers, manufacturers are continually challenged to find ways of incorporating these additional features in the limited space available within the device. Cameras are one such feature. Nokia has devoted considerable resources to developing ways to implement certain camera functionalities in portable electronic devices, such as mobile phones, while minimizing the space and energy consumed by such additional functionality. Traditionally, adding camera functionality required adding additional chips to the printed circuit board, which increased the size and power consumption of the device (see Figure 1 of the 256 patent (reproduced below)).

46. As shown in Figure 2 of the 256 patent (also reproduced below), the inventors of the 256 patent recognized that by integrating many of the features onto a single chip that communicates with a mobile processor, they could retain all of the features of a camera while reducing the size and power consumption of the overall device.

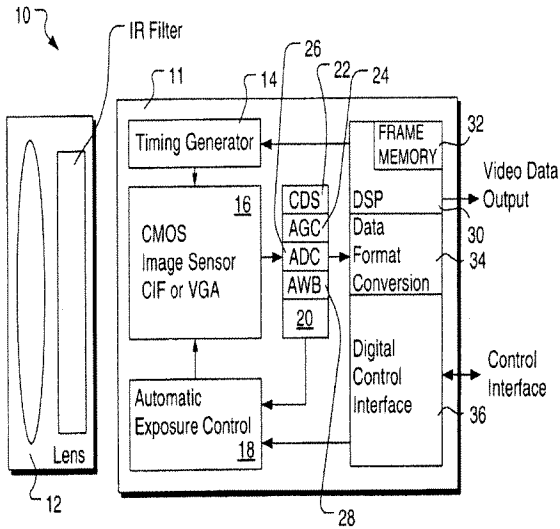

FIG. 1 (Prior Art)

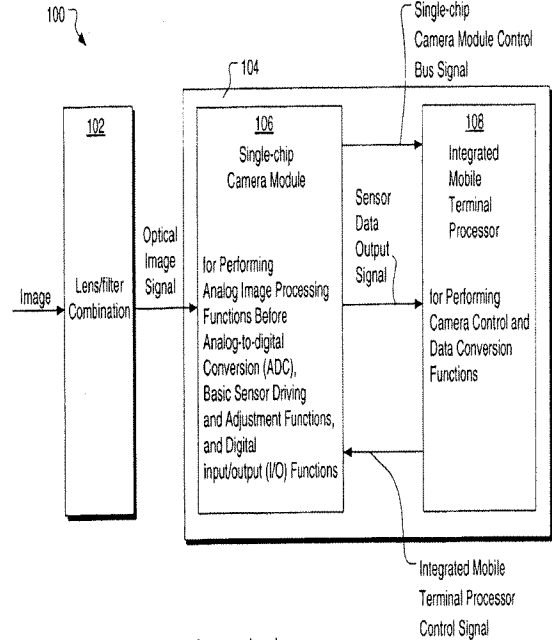

FIG. 2 (The Basic Invention)

47. In the Figures above, Figure 1 shows a number of camera components in a number of different chips. Figure 2 of the 256 patent shows a single-chip camera module (reference numeral 106) that performs a number of different functions in communication with a separate mobile terminal processor (reference numeral 108). This invention has allowed Nokia to build mobile phones with advanced camera functionality in some of the world's smallest and lightest phones.

E. The 957 Patent

48. U.S. Patent No. 6,518,957, entitled "Communications Device with Touch Sensitive Screen," issued on February 11, 2003 to inventors Kari Lehtinen and Kai Kronstrom. The 957 patent issued from United States Patent Application Serial No. 09/634,739, filed on August 8, 2000. The 957 patent expires on December 26, 2020.

49. A certified copy of the 957 patent is attached as Exhibit 4.

50. A certified copy of the prosecution history of the 957 patent and copies of each reference cited in the 957 patent and prosecution history are included in Appendices G and H, respectively.

51. The 957 patent has 25 claims, 6 of which are independent claims. Complainants are asserting claims 1, 10-13, 16, 19, 22, and 25.

52. Touch sensitive screens have recently become popular in portable devices. However, when a touch screen is used in a mobile phone, the touch screen can be accidentally triggered when the screen of the device is placed against the user's ear while talking on the phone.

53. Roughly a decade ago, the inventors of the 957 patent wanted to improve the touch screens for Nokia's mobile phones. They recognized that the user's ear may accidentally enter information while the phone is pressed against the ear during a call. The 957 invention disables the screen during a phone call to prevent such accidental data entry. As a pioneer in touch screen mobile applications, Nokia was the first to recognize and implement touch screen features that made the use of touch screens practical in mobile phones.

F. The 036 Patent

54. U.S. Patent No. 6,073,036, entitled "Mobile Station with Touch Input Having Automatic Symbol Magnification Function," issued on June 6, 2000 to inventors Teuvo Heikkinen, Petri Piippo, Harri Wikberg, Miika Silfverberg, Panu Korhonen, and Harri Kiljander. The 036 patent issued from United States Patent Application Serial No. 08/847,796, filed on April 28, 1997. The 036 patent expires on April 28, 2017.

55. A certified copy of the 036 patent is attached as Exhibit 5.

56. A certified copy of the prosecution history of the 036 patent and copies of each reference cited in the 036 patent and prosecution history are included in Appendices I and J, respectively.

57. The 036 patent has 19 claims, 2 of which are independent claims. Complainants are asserting claims 1, 3, 6, 8-10, 13, 17, and 19.

58. While touch screens have become increasingly popular in electronic devices, it can sometimes be difficult to enter information without a traditional keyboard. Often there is not enough space on the touch screen to display the full QWERTY keyboard and still provide enough space for the user's fingertip to access the desired key.

59. Early touch screen devices required the user to use a stylus to select the desired key. As shown in Figure 5B of the 036 patent (reproduced below), the inventors of the 036 patent recognized that they could reduce the need for a stylus by magnifying or expanding the portion of the screen pressed by the user's fingertip.

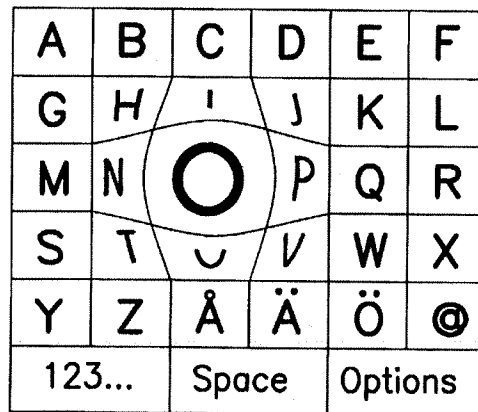

FIG. 5B

60. When a user places a finger on a desired key, it becomes larger so that the user can more easily identify the symbol that is about to be inputted. Nokia's innovation allowed

touch screens to be used in the minimal space afforded for the user interface in mobile devices by enhancing the user's interaction with the device and simplifying data entry.

G. The 735 Patent

61. U.S. Patent No. 6,262,735, entitled "Utilizing the Contents of a Message," issued on July 17, 2001 to inventor Esa Eteläperä. The 735 patent issued from United States Patent Application Serial No. 09/185,782, filed on November 4, 1998. The 735 patent expires on November 4, 2018.

62. A certified copy of the 735 patent is attached as Exhibit 6.

63. A certified copy of the prosecution history of the 735 patent and copies of each reference cited in the 735 patent and prosecution history are included in Appendices K and L, respectively.

64. The 735 patent has 10 claims, 2 of which are independent claims. Complainants are asserting claims 1-3 and 7-10.

65. As computers and mobile devices have evolved, the number of applications on these devices has increased. In addition, there has been an increased desire for interactivity among these applications. For example, a user may receive information in one application that he wishes to use in another application.

66. With early messaging applications, a user could receive information in a message that could be used in another application, such as a URL to use in a web browser or a phone number to use with a phone. But, to use that information, one would either need to remember it or write it down before exiting the messaging application to launch the other application. The inventor of the 735 patent realized the need to increase interactivity between applications on a computer or device.

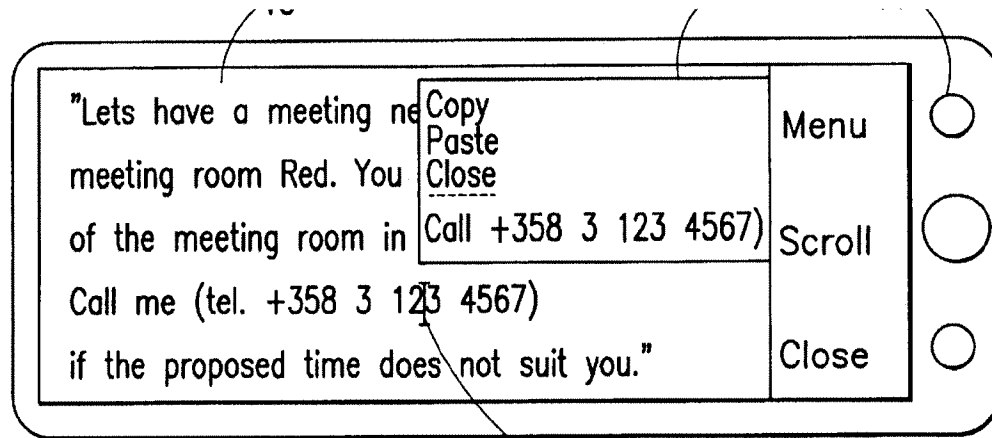

FIG. 1c 12

67. When a user receives a message such as a text message or an e-mail message that includes text in a form that could be used in another application (for example, a telephone number, designated by reference numeral 12 in the figure above or a URL), the messaging application recognizes this. Nokia's innovation allows a user to launch directly to the other application using the information in the message itself. The 735 invention saves the user time and makes the device easier to use.

H. The 789 Patent

68. U.S. Patent No. 6,924,789, entitled "User Interface Device," issued on August 2, 2005 to inventor Andrew Raymond Bick. The 789 patent issued from United States Patent Application Serial No. 09/942,373, filed on August 29, 2001. The 789 patent expires on August 29, 2021 plus a patent term extension of 609 days.

69. A certified copy of the 789 patent is attached as Exhibit 7.

70. A certified copy of the prosecution history of the 789 patent and copies of each reference cited in the 789 patent and prosecution history are included in Appendices M and N.

71. The 789 patent has 35 claims, 7 of which are independent claims. Complainants are asserting claim 5.

72. The number of applications and ways to interact with an electronic device have increased greatly. Often, the types of applications demand different ways to interact with the device at different times.

73. Early electronic devices only had one type of input device for a user. But new and different applications demand different types of interfaces, even as devices continue to get smaller. The inventor of the 789 patent invented a way to use one user input device in two different ways.

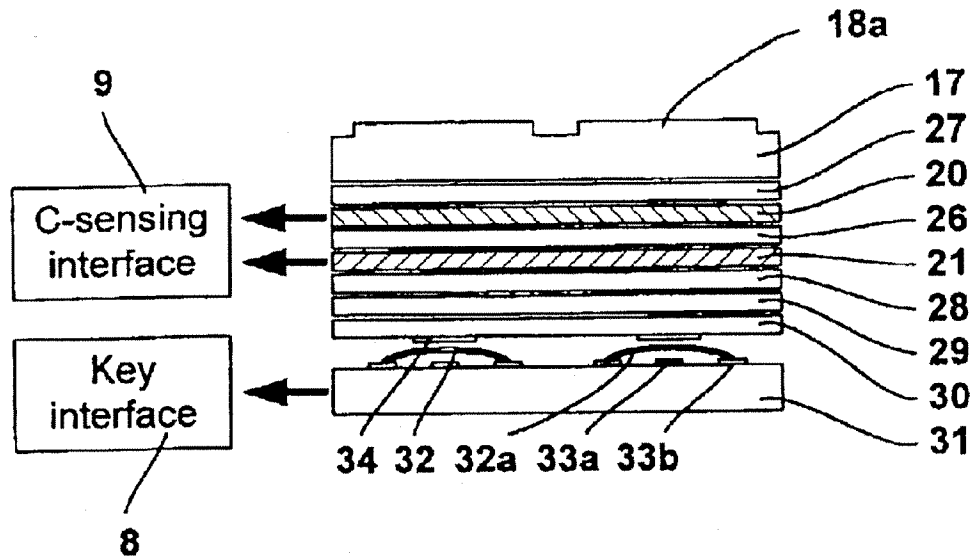

Figure 4

74. As shown in Figure 4 of the 789 patent above, a user can interact with the device in two ways. First, the user input has dome contacts (reference numeral 32) that provide a "snap" tactile response when the user depresses the key. Second, the interface also has an impedance sensor, designated by sensing plates 20 and 21. The impedance sensor provides a touch sensitive interface for the user to navigate through menus, selections, and other interactive applications.

I. Foreign Counterparts of the Asserted Patents

75. A list of each foreign patent, each foreign patent application (not already issued as a patent), and each foreign patent application that has been denied, abandoned, or withdrawn corresponding to the Asserted Patents, with an indication of the prosecution status of each such foreign patent application, is attached as Exhibit 17. No other foreign patents or patent applications corresponding to any of the Asserted Patents have been filed, abandoned, withdrawn, or rejected.

J. Licensees Under the Asserted Patents

76. Licensees under each of the Asserted Patents are identified in Confidential Exhibit 51.

VI. APPLE'S INFRINGEMENT OF THE ASSERTED PATENTS

77. As discussed in detail below, at least the Accused Products infringe the 091, 181, 256, 957, 036, 735, and/or 789 patents. Information regarding representative Accused Products discussed below may be found in Exhibits 18-23. The identification of a specific model or type of electronic device is not intended to limit the scope of the Investigation, and any remedy should extend to all infringing electronic devices.

A. Apple's Infringement of the 091 Patent

78. Apple directly infringes, contributes to infringement, and induces infringement with respect to at least claims 1-12 of the 091 patent with at least the following electronic devices: iPhone 3G and iPhone 3GS mobile phones (collectively, the "091 Accused Devices").

79. An exemplary claim chart showing infringement of independent claims 1 and 11 of the 091 patent by the iPhone 3GS mobile phone is attached as Confidential Exhibit 24.

1. Direct Infringement

80. Apple, directly and through authorized agents, sells and offers for sale the 091 Accused Devices within the United States. Nokia has purchased 091 Accused Devices in the United States directly from Apple. *See* Exhibit 31.

81. On information and belief, Apple sells and offers for sale the 091 Accused Devices to wireless system operators, distributors, independent retailers, and consumers in the United States.

82. On information and belief, Apple imports into the United States at least the 091 Accused Devices.

83. On information and belief, Apple tests or operates the 091 Accused Devices in the United States, thereby performing the claimed methods and directly infringing any asserted claims of the 091 patent requiring such operation.

84. Therefore, Apple directly infringes at least claims 1-12 of the 091 patent through its importation for sale, sale after importation, and/or use after importation of certain electronic devices.

2. Contributory Infringement

85. Apple also contributes to infringement of (and thereby infringes) at least claims 1-12 of the 091 patent in violation of 35 U.S.C. § 271 by selling within the United States, offering for sale within the United States, and/or importing components, including the 091 Accused Devices, and the non-staple constituent parts of those devices, that embody a material part of the inventions described in the 091 patent. These devices are known by Apple to be especially made or especially adapted for use in infringement of the 091 patent and are not staple articles or commodities suitable for substantial, non-infringing use.

86. Specifically, Apple sells the 091 Accused Devices, with knowledge that the devices infringe, through wholesale channels to resellers and directly to consumers. Consumers of those electronic devices directly infringe the 091 patent.

87. Nokia will put Apple on notice of the 091 patent and Apple's infringement thereof at least as early as the service of this Complaint.

3. Inducement of Infringement

88. Apple has also induced and continues to induce others to infringe claims 1-12 of the 091 patent in violation of 35 U.S.C. § 271 by encouraging and facilitating others to perform actions known by Apple to be acts of infringement of the 091 patent with intent that those performing the acts infringe the 091 patent. Apple, upon information and belief, *inter alia*, advertises regarding the 091 Accused Devices, publishes datasheets and promotional literature describing the operation of those devices, creates and/or distributes user manuals for the 091 Accused Devices, and offers support and technical assistance to its customers.

B. Apple's Infringement of the 181 Patent

89. Apple directly infringes, contributes to infringement, and induces infringement with respect to at least claims 1-6 and 8 of the 181 patent with at least the following electronic devices: iPhone 3G and iPhone 3GS mobile phones (collectively, the "181 Accused Devices").

90. An exemplary claim chart showing infringement of independent claims 1 and 4 of the 181 patent by the iPhone 3GS mobile phone is attached as Confidential Exhibit 25.

1. Direct Infringement

91. Apple, directly and through authorized agents, sells and offers for sale the 181 Accused Devices within the United States. Nokia has purchased 181 Accused Devices in the United States directly from Apple. *See* Exhibit 31.

92. On information and belief, Apple sells and offers for sale the 181 Accused Devices to wireless system operators, distributors, and independent retailers in the United States.

93. On information and belief, Apple imports into the United States at least the 181 Accused Devices.

94. Therefore, Apple directly infringes at least claims 1-6 and 8 of the 181 patent through its importation for sale and/or sale after importation of certain electronic devices.

2. Contributory Infringement

95. Apple also contributes to infringement of (and thereby infringes) at least claims 1-6 and 8 of the 181 patent in violation of 35 U.S.C. § 271 by selling within the United States, offering for sale within the United States, and/or importing components, including the 181 Accused Devices, and the non-staple constituent parts of those devices that embody a material part of the inventions described in the 181 patent. These devices are known by Apple to be especially made or especially adapted for use in infringement of the 181 patent and are not staple articles or commodities suitable for substantial, non-infringing use.

96. Specifically, Apple sells the 181 Accused Devices, with knowledge that the devices infringe, through wholesale channels to resellers and directly to consumers. Consumers of those electronic devices directly infringe the 181 patent.

97. Nokia will put Apple on notice of the 181 patent and Apple's infringement thereof at least as early as the service of this Complaint.

3. Inducement of Infringement

98. Apple has also induced and continues to induce others to infringe claims 1-6 and 8 of the 181 patent in violation of 35 U.S.C. § 271 by encouraging and facilitating others to perform actions known by Apple to be acts of infringement of the 181 patent with intent that those performing the acts infringe the 181 patent. Apple, upon information and belief, *inter alia*,

advertises regarding the 181 Accused Devices, publishes datasheets and promotional literature describing the operation of those devices, creates and/or distributes user manuals for the 181 Accused Devices, and offers support and technical assistance to its customers.

C. Apple's Infringement of the 256 Patent

99. Apple directly infringes, contributes to infringement, and induces infringement with respect to at least claims 1, 3 6-10, 14, and 16 of the 256 patent with at least the following electronic devices: iPhone 3G and iPhone 3GS mobile phones, the iPod Nano portable music player, and the MacBook, MacBook Pro, and MacBook Air computers (collectively, the "256 Accused Devices").

100. An exemplary claim chart showing infringement of independent claim 1 of the 256 patent by the iPhone 3GS mobile phone is attached as Confidential Exhibit 26.

1. Direct Infringement

101. Apple, directly and through authorized agents, sells and offers for sale the 256 Accused Devices within the United States. Nokia has purchased 256 Accused Devices in the United States directly from Apple. *See* Exhibit 31.

102. On information and belief, Apple sells and offers for sale the 256 Accused Devices to wireless system operators, distributors, independent retailers and consumers in the United States.

103. On information and belief, Apple imports into the United States at least the 256 Accused Devices.

104. Therefore, Apple directly infringes at least claims 1, 3, 6-10, 14, and 16 of the 256 patent through its importation for sale and/or sale after importation of certain electronic devices.

2. Contributory Infringement

105. Apple also contributes to infringement of (and thereby infringes) at least claims 1, 3, 6-10, 14, and 16 of the 256 patent in violation of 35 U.S.C. § 271 by selling within the United States, offering for sale within the United States, and/or importing components, including the 256 Accused Devices, and the non-staple constituent parts of those devices that embody a material part of the inventions described in the 256 patent. These devices are known by Apple to be especially made or especially adapted for use in infringement of the 256 patent and are not staple articles or commodities suitable for substantial, non-infringing use.

106. Specifically, Apple sells the 256 Accused Devices, with knowledge that the devices infringe, through wholesale channels to resellers and directly to consumers. Consumers of those electronic devices directly infringe the 256 patent.

107. Nokia will put Apple on notice of the 256 patent and Apple's infringement thereof at least as early as the service of this Complaint.

3. Inducement of Infringement

108. Apple has also induced, and continues to induce others to infringe claims 1, 3, 6-10, 14, and 16 of the 256 patent in violation of 35 U.S.C. § 271, by encouraging and facilitating others to perform actions known by Apple to be acts of infringement of the 256 patent with intent that those performing the acts infringe the 256 patent. Apple, upon information and belief, *inter alia*, advertises regarding the 256 Accused Devices, publishes datasheets and promotional literature describing the operation of those devices, creates and/or distributes user manuals for the 256 Accused Devices, and offers support and technical assistance to its customers.

D. Apple's Infringement of the 957 Patent

109. Apple directly infringes, contributes to infringement, and induces infringement with respect to at least claims 1, 10-13, 16, 19, 22, and 25 of the 957 patent with at least the

following electronic devices: iPhone 3G and iPhone 3GS mobile phones (collectively, the "957 Accused Devices").

110. An exemplary claim chart showing infringement of independent claims 1, 13, 16, 19, 22, and 25 of the 957 patent by the iPhone 3GS mobile phone is attached as Confidential Exhibit 27.

1. Direct Infringement

111. Apple, directly and through authorized agents, sells and offers for sale the 957 Accused Devices within the United States. Nokia has purchased 957 Accused Devices in the United States directly from Apple. *See* Exhibit 31.

112. On information and belief, Apple sells and offers for sale the 957 Accused Devices to wireless system operators, distributors, independent retailers and consumers in the United States.

113. On information and belief, Apple imports into the United States at least the 957 Accused Devices.

114. On information and belief, Apple tests or operates the 957 Accused Devices, in the United States, thereby performing the claimed methods and directly infringing any asserted claims of the 957 patent requiring such operation.

115. Therefore, Apple directly infringes at least claims 1, 10-13, 16, 19, 22, and 25 of the 957 patent through its importation for sale, sale after importation and/or use after importation of certain electronic devices.

2. Contributory Infringement

116. Apple also contributes to infringement of (and thereby infringes) at least claims 1, 10-13, 16, 19, 22, and 25 of the 957 patent in violation of 35 U.S.C. § 271 by selling within the United States, offering for sale within the United States, and/or importing components, including

the 957 Accused Devices, and the non-staple constituent parts of those devices that embody a material part of the inventions described in the 957 patent. These devices are known by Apple to be especially made or especially adapted for use in infringement of the 957 patent and are not staple articles or commodities suitable for substantial, non-infringing use.

117. Specifically, Apple sells the 957 Accused Devices, with knowledge that the devices infringe, through wholesale channels to resellers and directly to consumers. Consumers of those electronic devices directly infringe the 957 patent.

118. Nokia will put Apple on notice of the 957 patent and Apple's infringement thereof at least as early as the service of this Complaint.

3. Inducement of Infringement

119. Apple has also induced and continues to induce others to infringe claims 1, 10-13, 16, 19, 22, and 25 of the 957 patent in violation of 35 U.S.C. § 271 by encouraging and facilitating others to perform actions known by Apple to be acts of infringement of the 957 patent with intent that those performing the acts infringe the 957 patent. Apple, upon information and belief, *inter alia*, advertises regarding the 957 Accused Devices, publishes datasheets and promotional literature describing the operation of those devices, creates and/or distributes user manuals for the 957 Accused Devices, and offers support and technical assistance to its customers.

E. Apple's Infringement of the 036 Patent

120. Apple directly infringes, contributes to infringement, and induces infringement with respect to at least claims 1, 3, 6, 8-10, 13, 17, and 19 of the 036 patent with at least the following electronic devices: iPhone 3G and iPhone 3GS mobile phones and the iPod Touch portable music player (collectively, the "036 Accused Devices").

121. An exemplary claim chart showing infringement of independent claims 1 and 8 of the 036 patent by the iPhone 3GS mobile phone is attached as Confidential Exhibit 28.

1. Direct Infringement

122. Apple, directly and through authorized agents, sells and offers for sale the 036 Accused Devices within the United States. Nokia has purchased 036 Accused Devices in the United States directly from Apple. *See* Exhibit 31.

123. On information and belief, Apple sells and offers for sale the 036 Accused Devices to wireless system operators, distributors, independent retailers and consumers in the United States.

124. On information and belief, Apple imports into the United States at least the 036 Accused Devices.

125. On information and belief, Apple tests or operates the 036 Accused Devices, in the United States, thereby performing the claimed methods and directly infringing any asserted claims of the 036 patent requiring such operation.

126. Therefore, Apple directly infringes at least claims 1, 3, 6, 8-10, 13, 17, and 19 of the 036 patent through its importation for sale, sale after importation and/or use after importation of certain electronic devices.

2. Contributory Infringement

127. Apple also contributes to infringement of (and thereby infringes) at least claims 1, 3, 6, 8-10, 13, 17, and 19 of the 036 patent in violation of 35 U.S.C. § 271 by selling within the United States, offering for sale within the United States, and/or importing components, including the 036 Accused Devices, and the non-staple constituent parts of those devices that embody a material part of the inventions described in the 036 patent. These devices are known by Apple to

be especially made or especially adapted for use in infringement of the 036 patent and are not staple articles or commodities suitable for substantial, non-infringing use.

128. Specifically, Apple sells the 036 Accused Devices, with knowledge that the devices infringe, through wholesale channels to resellers and directly to consumers. Consumers of those electronic devices directly infringe the 036 patent.

129. Nokia will put Apple on notice of the 036 patent and Apple's infringement thereof at least as early as the service of this Complaint.

3. Inducement of Infringement

130. Apple has also induced, and continues to induce others to infringe claims 1, 3, 6, 8-10, 13, 17, and 19 of the 036 patent in violation of 35 U.S.C. § 271, by encouraging and facilitating others to perform actions known by Apple to be acts of infringement of the 036 patent with intent that those performing the acts infringe the 036 patent. Apple, upon information and belief, *inter alia*, advertises regarding the 036 Accused Devices, publishes datasheets and promotional literature describing the operation of those devices, creates and/or distributes user manuals for the 036 Accused Devices, and offers support and technical assistance to its customers.

F. Apple's Infringement of the 735 Patent

131. Apple directly infringes, contributes to infringement, and induces infringement with respect to at least claims 1-3 and 7-10 of the 735 patent with at least the following electronic devices: iPhone 3G and iPhone 3GS mobile phones, the iPod Touch portable music player and the MacBook, MacBook Pro, MacBook Air, iMac, Mac Mini, and Mac Pro computers (collectively, the "735 Accused Devices").

132. An exemplary claim chart showing infringement of independent claims 1 and 7 of the 735 patent by the iPhone 3GS mobile phone is attached as Exhibit 29.

1. Direct Infringement

133. Apple, directly and through authorized agents, sells and offers for sale the 735 Accused Devices within the United States. Nokia has purchased 735 Accused Devices in the United States directly from Apple. *See* Exhibit 31.

134. On information and belief, Apple sells and offers for sale the 735 Accused Devices to wireless system operators, distributors, independent retailers and consumers in the United States.

135. On information and belief, Apple imports into the United States at least the 735 Accused Devices.

136. On information and belief, Apple tests or operates the 735 Accused Devices in the United States, thereby performing the claimed methods and directly infringing any asserted claims of the 735 patent requiring such operation.

137. Therefore, Apple directly infringes at least claims 1-3 and 7-10 of the 735 patent through its importation for sale, sale after importation and/or use after importation of certain electronic devices.

2. Contributory Infringement

138. Apple also contributes to infringement of (and thereby infringes) at least claims 1-3 and 7-10 of the 735 patent in violation of 35 U.S.C. § 271 by selling within the United States, offering for sale within the United States, and/or importing components, including the 735 Accused Devices, and the non-staple constituent parts of those devices that embody a material part of the inventions described in the 735 patent. These devices are known by Apple to be especially made or especially adapted for use in infringement of the 735 patent and are not staple articles or commodities suitable for substantial, non-infringing use.

139. Specifically, Apple sells the 735 Accused Devices, with knowledge that the devices infringe, through wholesale channels to resellers and directly to consumers. Consumers of those electronic devices directly infringe the 735 patent.

140. Nokia will put Apple on notice of the 735 patent and Apple's infringement thereof at least as early as the service of this Complaint.

3. Inducement of Infringement

141. Apple has also induced, and continues to induce others to infringe claims 1-3 and 7-10 of the 735 patent in violation of 35 U.S.C. § 271, by encouraging and facilitating others to perform actions known by Apple to be acts of infringement of the 735 patent with intent that those performing the acts infringe the 735 patent. Apple, upon information and belief, *inter alia*, advertises regarding the 735 Accused Devices, publishes datasheets and promotional literature describing the operation of those devices, creates and/or distributes user manuals for the 735 Accused Devices, and offers support and technical assistance to its customers.

G. Apple's Infringement of the 789 Patent

142. Apple directly infringes, contributes to infringement, and induces infringement with respect to at least claim 5 of the 789 patent with at least the following electronic devices: iPod Nano and iPod Classic portable music players (collectively, the "789 Accused Devices").

143. An exemplary claim chart showing infringement of independent claim 5 of the 789 patent by the iPod Nano portable music player is attached as Confidential Exhibit 30.

1. Direct Infringement

144. Apple, directly and through authorized agents, sells and offers for sale the 789 Accused Devices within the United States. Nokia has purchased 789 Accused Devices in the United States directly from Apple. *See* Exhibit 31.

145. On information and belief, Apple sells and offers for sale the 789 Accused Devices to distributors, independent retailers and consumers in the United States.

146. On information and belief, Apple imports into the United States at least the 789 Accused Devices.

147. Therefore, Apple directly infringes at least claim 5 of the 789 patent through its importation for sale and/or sale after importation of certain electronic devices.

2. Contributory Infringement

148. Apple also contributes to infringement of (and thereby infringes) at least claim 5 of the 789 patent in violation of 35 U.S.C. § 271 by selling within the United States, offering for sale within the United States, and/or importing components, including the 789 Accused Devices, and the non-staple constituent parts of those devices that embody a material part of the inventions described in the 789 patent. These devices are known by Apple to be especially made or especially adapted for use in infringement of the 789 patent and are not staple articles or commodities suitable for substantial, non-infringing use.

149. Specifically, Apple sells the 789 Accused Devices, with knowledge that the devices infringe, through wholesale channels to resellers and directly to consumers. Consumers of those electronic devices directly infringe the 789 patent.

150. Nokia will put Apple on notice of the 789 patent and Apple's infringement thereof at least as early as the service of this Complaint.

3. Inducement of Infringement

151. Apple has also induced, and continues to induce others to infringe claim 5 of the 789 patent in violation of 35 U.S.C. § 271, by encouraging and facilitating others to perform actions known by Apple to be acts of infringement of the 789 patent with intent that those performing the acts infringe the 789 patent. Apple, upon information and belief, *inter alia*,

advertises regarding the 789 Accused Devices, publishes datasheets and promotional literature describing the operation of those devices, creates and/or distributes user manuals for the 789 Accused Devices, and offers support and technical assistance to its customers.

VII. APPLE'S UNFAIR TRADE PRACTICES

152. On information and belief, Apple sells for importation, imports, and/or sells after importation its infringing electronic devices.

153. On information and belief, Apple's Accused Products are manufactured abroad, sold for importation, imported and sold after importation in the United States by Apple or Apple's vendors. For example, Exhibit 16 contains Apple's 10-K for the fiscal year ending September 27, 2008. The 10-K indicates that third party vendors in China perform final assembly of substantially all of Apple's mobile phones, portable music players and computers. *See* Exhibit 16 at 11. The 10-K also indicates that 57% of Apple's sales in 2008 were in the United States. *Id.*

154. Exhibit 31 is the Declaration of Laura Williams regarding the purchase of sample Accused Products at Apple stores in the United States.

155. Physical Exhibit P1 is an Apple iPhone 3GS mobile phone purchased from Apple in the United States. Exhibit 32 contains photographs of this iPhone 3GS mobile phone showing that the iPhone 3GS's packaging indicates that it was assembled in China. Physical Exhibit P2 is an Apple iPod Nano portable music player purchased from Apple in the United States. Exhibit 33 contains photographs of the Apple iPod Nano, Apple iPod Touch and Apple iPod Classic portable music players purchased from Apple in the United States showing that their packaging indicates that they were all assembled in China. Exhibit 34 contains photographs of the Apple MacBook and Apple iMac computers purchased from Apple in the United States showing that their packaging indicates that they were also assembled in China.

VIII. TARIFF NUMBERS APPLICABLE TO THE ACCUSED PRODUCTS

156. On information and belief, the Accused Products have been imported into the United States under at least Harmonized Tariff Schedule of the United States item numbers 8517.12.00 (mobile phones); 8519.81.40, 8519.89.30, or 8521.90.00 (portable music players); and 8471.30.01, 8471.41.01, or 8471.49.00 (computers).

IX. RELATED LITIGATION

157. Concurrent with the filing of this complaint, Nokia Corporation will file a civil action in the United States District Court for the District of Delaware accusing Apple of infringement of the Asserted Patents. There has been no other foreign or domestic court or agency litigation relating to the unfair acts alleged herein.

X. THE DOMESTIC INDUSTRY

158. An industry as required by Section 337(a)(2) and defined by Section 337(a)(3) exists in the United States relating to Nokia's mobile phones protected by the Asserted Patents.

A. Nokia's Articles Protected by the Asserted Patents

159. Many of Nokia's mobile phones practice the Asserted Patents. However, for purposes of outlining Nokia's satisfaction of the domestic industry requirement, Nokia has selected five representative Nokia mobile phones: 7205, E62, E71x, 5800, and N85, which are included as Physical Exhibits P3, P4,⁸ P5, P6, and P7, respectively. Photographs of these Nokia mobile phones are included in Exhibit 35.

⁸ The more recent Nokia E61i is included as Physical Exhibit P4 and shown in Exhibit 35 instead of the similar Nokia E62. Both mobile phones practice the 181 patent as described in Confidential Exhibit 45.

160. Confidential Exhibits 36 and 37 contain technical information regarding the Nokia 7205 mobile phone. Confidential Exhibit 44 contains a claim chart showing that the Nokia 7205 mobile phone practices at least claim 1 of the 091 patent.

161. Confidential Exhibit 38 contains technical information regarding the Nokia E62 mobile phone. Confidential Exhibit 45 contains a claim chart showing that the Nokia E62 mobile phone practices at least claim 1 of the 181 patent. This analysis is also applicable to the Nokia E61i mobile phone.

162. Confidential Exhibit 39 and Exhibit 40 contain technical information regarding the Nokia E71x mobile phone. Confidential Exhibits 46 and 49 contain claim charts showing that the Nokia E71x mobile phone practices at least claim 1 of the 256 patent and claim 1 of the 735 patent.

163. Exhibit 41 contains technical information regarding the Nokia 5800 mobile phone. Confidential Exhibits 47 and 48 contain claim charts showing that the Nokia 5800 mobile phone practices at least claim 1 of the 957 patent and claim 1 of the 036 patent.

164. Confidential Exhibit 42 and Exhibit 43 contain technical information regarding the Nokia N85 mobile phone. Confidential Exhibit 50 contains a claim chart showing that the Nokia N85 mobile phones practice at least claim 22 of the 789 patent. This analysis is also applicable to the Nokia N78 and N81 mobile phones.

B. Nokia's Investments in the United States with respect to the Articles Protected by the Asserted Patents

165. Nokia has made substantial investments in the United States in the exploitation of the Asserted Patents. These investments include at least domestic engineering, research and development, testing, and repair and service relating to articles protected by the Asserted Patents. Over 1,000 employees located in Nokia's facilities across the United States are involved in

engineering and research and development. For purposes of outlining its satisfaction of the economic prong of the domestic industry requirement, Nokia has selected the following discrete domestic investments relating to the Nokia mobile phones described above that are protected by the Asserted Patents.

1. Investments Relating to Engineering and Research and Development

166. Nokia employees in San Diego, California; Irving, Texas; Boston, Massachusetts; Mountain View, California; San Francisco, California; Kirkland, Washington; and Parsippany, New Jersey conduct engineering and research and development relating to Nokia mobile phones protected by the Asserted Patents.

167. As described in Confidential Exhibits 52-54, Nokia has made substantial investments in employees and plant and equipment to support engineering and research and development in the United States relating to the Nokia E62, E61i, E71x, 5800, N78, N81 and N85 mobile phones.

168. For example, in March 2005, Nokia began developing the E62 mobile phone in its Irving facility. Nokia's domestic investments in employees and plant and equipment to support this development are described in Confidential Exhibit 52.

169. Following Nokia's successful development of the E62 mobile phone, a team in Nokia's San Diego facility began developing the E71x mobile phone in February 2008. Prior to its release in May 2009, approximately 70 researchers, engineers, and others worked on the E71x development project. Nokia's domestic investments in employees and plant and equipment to support the development of the Model E71x mobile phone are described in more detail Confidential Exhibit 52.

170. Web browser and applications development for Nokia's mobile phones protected by the Asserted Patents takes place in Nokia's Boston, Mountain View, San Francisco, and

Kirkland facilities. Web browser releases and applications designed and developed in these facilities are included in Nokia's E62, E61i, E71x, 5800, N78, N81, and N85 mobile phones. Nokia's domestic investments in employees and plant and equipment relating to web browser and applications development for the selected Nokia mobile phones protected by the Asserted Patents are described in more detail in Confidential Exhibits 53-54.

171. Employees in Nokia's San Diego and Parsippany facilities designed the Nokia 7205 mobile phone. Nokia's domestic investments in employees and plant and equipment to support the development of the in the Nokia 7205 mobile phone are detailed in Confidential Exhibit 55.

2. Investments Relating to Testing

172. In order to support its products and customers, Nokia has made and continues to make substantial investments in the United States to test its mobile phones that practice the Asserted Patents.

173. Each Nokia phone model produced for the United States market undergoes rigorous testing in the United States by Nokia engineers or third party contractors under their direction. Nokia employees in Nokia's San Diego and Irving facilities are responsible for a wide variety of testing, including environmental testing, mechanical testing, failure analysis testing, and laboratory testing. In addition, Nokia employees or third party contractors field test each Nokia phone model at multiple locations throughout the United States. Nokia's domestic investments in testing the selected Nokia mobile phones protected by the Asserted Patents are described in more detail in Confidential Exhibits 52 and 56.

174. In addition, certain wireless carriers require that Nokia mobile phones be tested by third party testing facilities in the United States. Nokia's investments at these domestic third party testing facilities are also described in Confidential Exhibits 52 and 56.

3. Investments Relating to Repair and Service

175. Nokia has made and continues to make substantial investments in the United States relating to the repair and service of Nokia's mobile phones that practice the Asserted Patents.

176. Employees in Nokia's Irving facility are responsible for overseeing the service and repair of Nokia mobile phones in the United States. There, Nokia employees supervise the activities of more than 200 domestic sub-contracted employees who perform service and repair activities on Nokia's behalf. Confidential Exhibit 57 describes Nokia's expenditures relating to the service and repair of the selected Nokia mobile phones protected by the Asserted Patents.

XI. COMPLAINANTS' REQUEST FOR RELIEF

177. Complainants Nokia Corporation and Nokia Inc. respectfully request that the United States International Trade Commission:

- (a) Institute an immediate investigation, pursuant to Section 337 of the Tariff Act of 1930, as amended, 19 U.S.C. § 1337, with respect to violations of Section 337 based upon the importation into the United States, the sale for importation, and/or the sale within the United States after importation of Apple's electronic devices that infringe one or more claims of the Asserted Patents;
- (b) Determine that there has been a violation of Section 337 by Apple;
- (c) Issue a permanent exclusion order, pursuant to 19 U.S.C. § 1337(d)(1), prohibiting entry into the United States or admission into Foreign Trade Zones in the United States of all of Apple's electronic devices that infringe one or more claims of the Asserted Patents;
- (d) Issue a permanent cease and desist order, pursuant to 19 U.S.C. § 1337(f), prohibiting Apple, its affiliates, and others acting on behalf of Apple, from

- importing, admitting, or withdrawing from a foreign trade zone, marketing, advertising, demonstrating, warehousing inventory for distribution, distributing, offering for sale, selling, licensing, repairing, maintaining, updating, using, or transferring outside the United States for sale in the United States any of Apple's electronic devices that infringe one or more claims of the Asserted Patents; and
- (e) Issue such other and further relief as the Commission deems just and proper based on the facts determined by the investigation and the authority of the Commission.

DATED: December 29, 2009

Respectfully submitted,

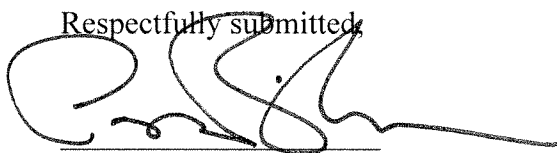

Paul F. Brinkman
Alan L. Whitehurst
ALSTON & BIRD LLP
The Atlantic Building
950 F Street, NW
Washington, D.C. 20004-1404

Patrick J. Flinn
Keith E. Broyles
John D. Haynes
ALSTON & BIRD LLP
One Atlantic Center
1201 West Peachtree Street
Atlanta, GA 30309-3424

Counsel for Complainants
Nokia Corporation and Nokia Inc.

VERIFICATION OF COMPLAINT

I, Paul Melin, declare under penalty of perjury under the laws of the United States of America, and in accordance with 19 C.F.R. §§ 210.4 and 210.12(a) the following is true and correct:

1. I am General Manager, Patent Licensing, of Nokia Corporation, and am duly authorized to verify this complaint on behalf of complainants;
2. I have read the complaint and am aware of its contents;
3. The complaint is not being presented for any improper purpose, such as to harass or to cause unnecessary delay or needlessly increase in the cost of litigation;
4. To the best of my knowledge, information and belief founded upon reasonable inquiry, the claims and legal contentions of this complaint are warranted by existing law or a good faith argument for the extension, modification or reversal of existing law;
5. To the best of my knowledge, information and belief founded upon reasonable inquiry, the allegations and other factual contentions in the complaint have evidentiary support or are likely to have evidentiary support after a reasonable opportunity for further investigation or discovery.

Executed on December 23, 2009



Paul Melin